

Product: COMPACTOR

Model: CB-32B COMPACTOR 469

Configuration: CB32B Compactor 46900001-UP (MACHINE) POWERED BY C1.5 Electric Power Generation

## **Disassembly and Assembly C1.1, C1.5 and C2.2 Engines for Caterpillar Built Machines**

Media Number -KENR6948-06

Publication Date -01/06/2015

Date Updated -02/08/2018

i07360659

# **Fuel Injection Lines - Remove and Install**

SMCS - 1252-010

## **Removal Procedure**

---

### **NOTICE**

**Keep all parts clean from contaminants.**

**Contaminants may cause rapid wear and shortened component life.**

---

---

### **NOTICE**

**Care must be taken to ensure that fluids are contained during performance of inspection, maintenance, testing, adjusting and repair of the product. Be prepared to collect the fluid with suitable containers before opening any compartment or disassembling any component containing fluids.**

**Dispose of all fluids according to local regulations and mandates.**

---

---

### **NOTICE**

**Do not let the tops of fuel injectors turn when the fuel line nuts are loosened or tightened.**

**The fuel injectors will be damaged if the top of the injector turns in the body.**

**The engine will be damaged if a defective fuel injector is used because the shape of fuel (spray pattern) that comes out of the nozzle will not be correct.**

---

**Note:** Place identification marks on all tube assemblies for installation. Plug all lines and tube assemblies to prevent contamination.

1. Turn the fuel supply to the OFF position.

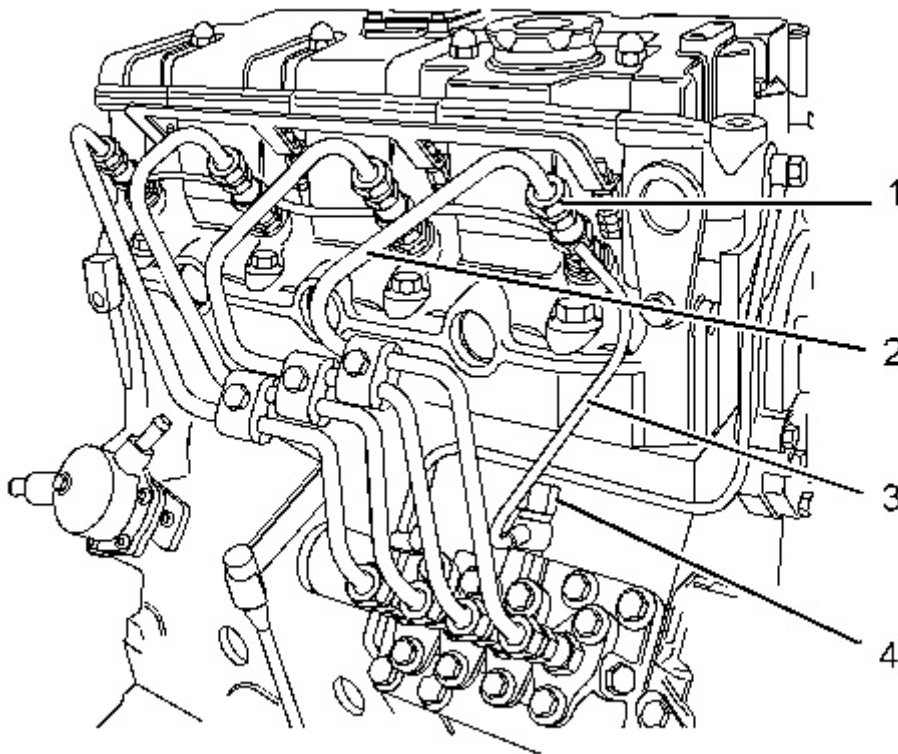

---

Illustration 1  
Typical example

g01326550

2. Disconnect nuts (1) for fuel injection lines (2) from the fuel injectors.
3. Disconnect nuts (1) for fuel injection lines (2) from the fuel injection pump.
4. Remove fuel injection lines (2) from the engine as a unit.
5. Use suitable caps to plug the open ports of the fuel injection pump immediately.
6. The C1.5 and C2.2 engines have a rigid fuel return line.

For engines with a rigid fuel return line, remove banjo bolt (4) from fuel return line (3). Remove washers (8).

The C1.1 engine has a flexible fuel return hose.

For engines with a flexible fuel return hose, disconnect the hose from the fuel injection pump.

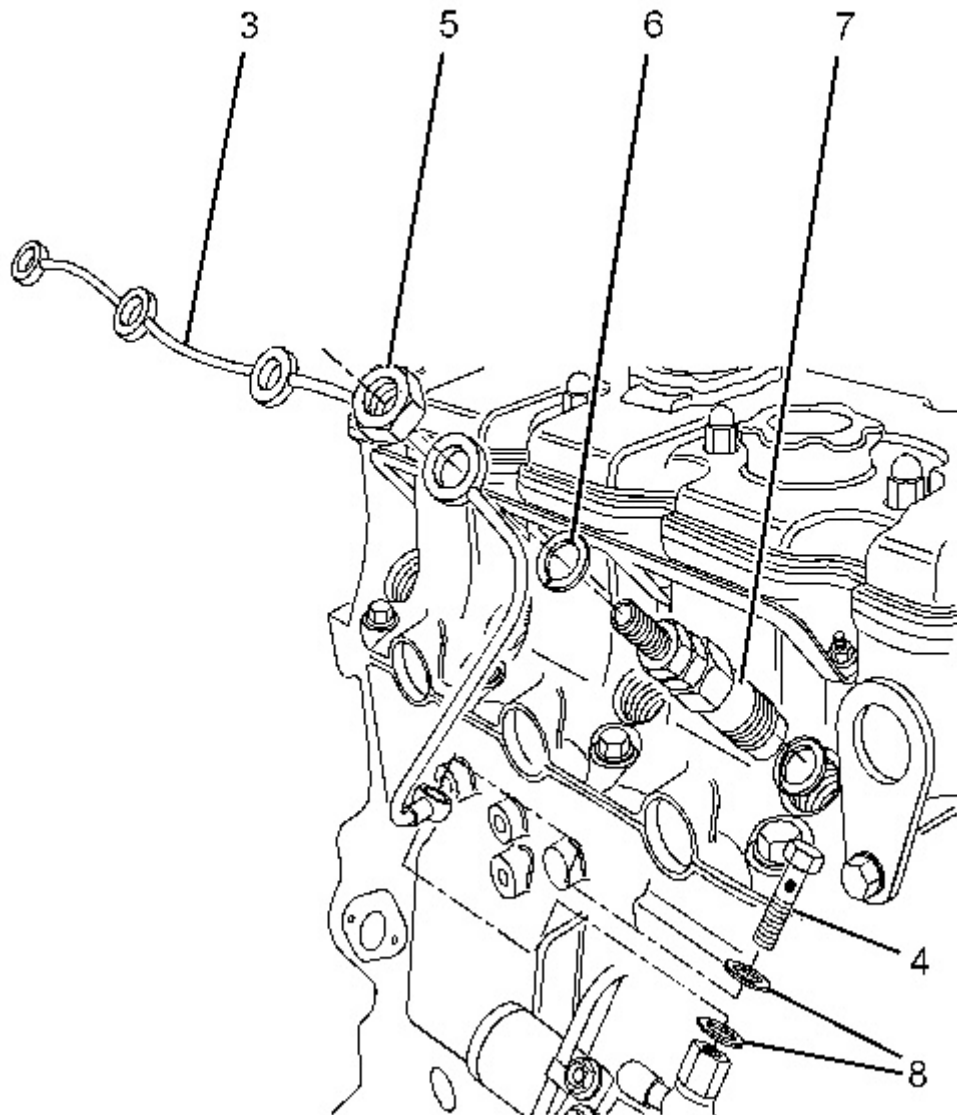

Illustration 2  
Typical example

g01326555

7. Remove nuts (5) from fuel injectors (7).

**Note:** For engines with a rigid fuel return line, ensure that the fuel return line is not distorted when the nuts are loosened.

8. Remove fuel return line (3) and washers (6) from fuel injectors (7).

9. Use suitable caps to plug the fuel injectors immediately.

## Installation Procedure

Table 1

Required Tools			
Tool	Part Number	Part Name	Qty
A	276-1216	Injector Pipe Nut Tool	1

---

### NOTICE

**Keep all parts clean from contaminants.**

**Contaminants may cause rapid wear and shortened component life.**

---

---

### NOTICE

**Do not let the tops of fuel injectors turn when the fuel line nuts are loosened or tightened.**

**The fuel injectors will be damaged if the top of the injector turns in the body.**

**The engine will be damaged if a defective fuel injector is used because the shape of fuel (spray pattern) that comes out of the nozzle will not be correct.**

---

**Note:** The installation procedure is similar for the three cylinder and the four cylinder engines.

---

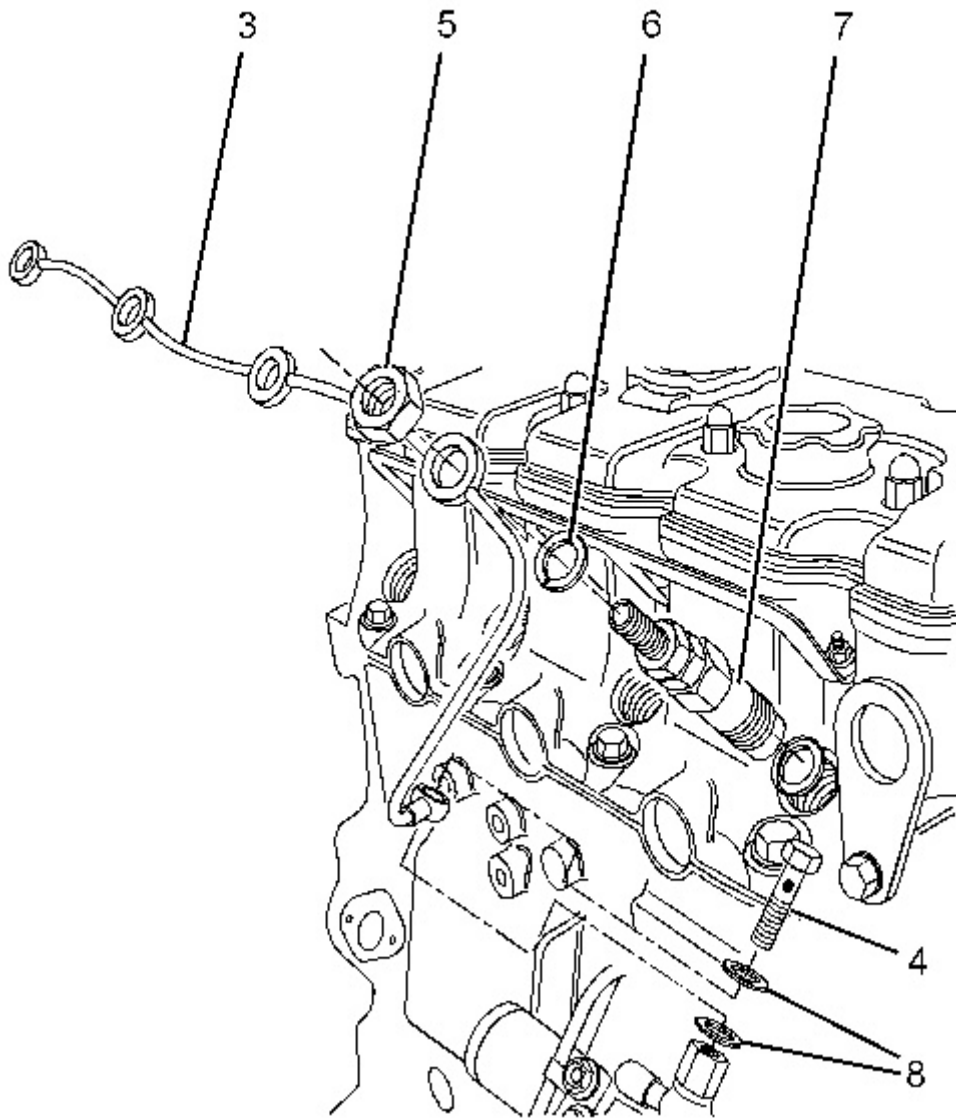

Illustration 3

g01326555

Typical example

1. Remove the caps from fuel injectors (7). Install new washers (6) and fuel return line (3) to fuel injectors (7).

**Note:** The washers (6) have two small holes.

2. Install nuts (5) to fuel injectors (7).
3. The C1.5 and C2.2 engines have a rigid fuel return line.

For engines with a rigid fuel return line, install new washers (8) to fuel return line (3) and install banjo bolt (4) to the fuel injection pump. Tighten banjo bolt (4) to a torque of 7 N·m (62 lb in).

The C1.1 engine has a flexible fuel return hose.

For engines with a flexible fuel return hose, connect the fuel return hose to the fuel injection pump.

4. Tighten nuts (5) to a torque of 27 N·m (239 lb in).

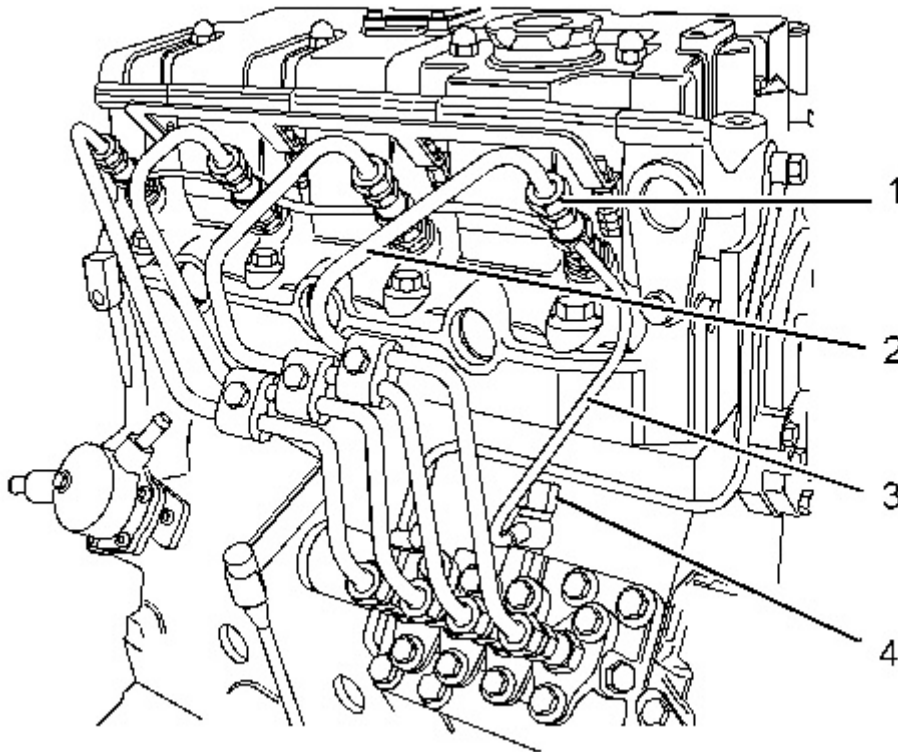

---

Illustration 4  
Typical example

g01326550

5. Remove the caps from the outlet connections of the fuel injection pump. Install the fuel injection lines to the engine as a unit.
6. Connect fuel injection lines (2) to fuel injectors (7). Tighten the union nuts (1) finger tight.
7. Use Tooling (A) to tighten union nuts (1) at the fuel injection pump.  
Tighten the union nuts (1) to a torque of 23 N·m (204 lb in).  
**Note:** Tighten the center union nuts first.
8. Use Tooling (A) to tighten union nuts (1) at the fuel injectors.  
Tighten the union nuts (1) to a torque of 23 N·m (204 lb in).
9. Turn the fuel supply to the ON position.
10. Prime the fuel system. Refer to Operation and Maintenance Manual, "Fuel System - Prime" for more information.

Product: COMPACTOR

Model: CB-32B COMPACTOR 469

Configuration: CB32B Compactor 46900001-UP (MACHINE) POWERED BY C1.5 Electric Power Generation

## **Disassembly and Assembly C1.1, C1.5 and C2.2 Engines for Caterpillar Built Machines**

Media Number -KENR6948-06

Publication Date -01/06/2015

Date Updated -02/08/2018

i02602637

# **Fuel Shutoff Solenoid - Remove and Install**

SMCS - 1259-010

## **Removal Procedure**

---

### **NOTICE**

**Care must be taken to ensure that fluids are contained during performance of inspection, maintenance, testing, adjusting and repair of the product. Be prepared to collect the fluid with suitable containers before opening any compartment or disassembling any component containing fluids.**

**Dispose of all fluids according to local regulations and mandates.**

---

---

### **NOTICE**

**Keep all parts clean from contaminants.**

**Contaminants may cause rapid wear and shortened component life.**

---

1. Turn the battery disconnect switch to the OFF position.
-

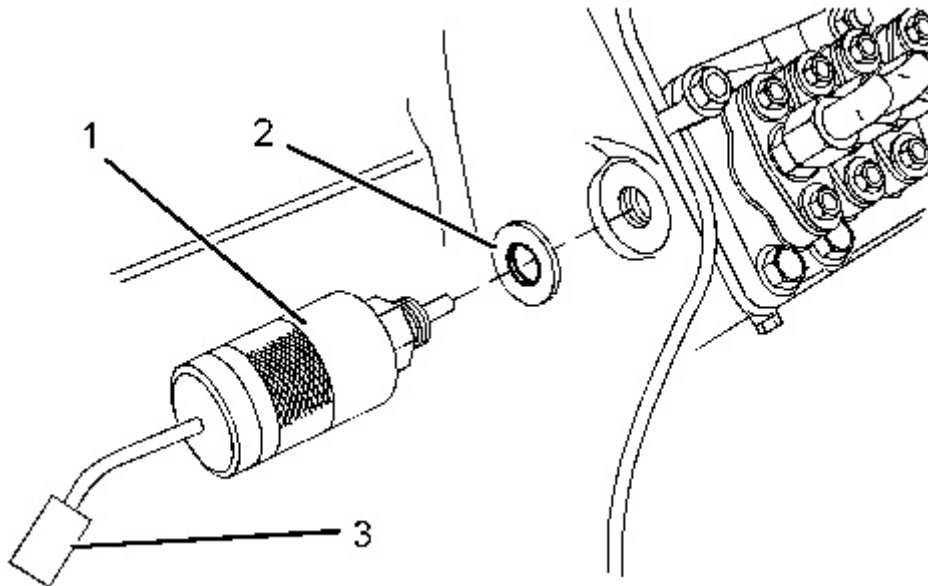

Illustration 1

g01326564

Typical example

2. Disconnect electrical connection (3) from the harness assembly (not shown). Mark all connections for installation.
3. Remove fuel shutoff solenoid (1) from the fuel injection pump housing by rotating the fuel shutoff solenoid in a counterclockwise direction.
4. Remove sealing washer (2) from fuel shutoff solenoid (1).

## Installation Procedure

---

### NOTICE

**Keep all parts clean from contaminants.**

**Contaminants may cause rapid wear and shortened component life.**

---



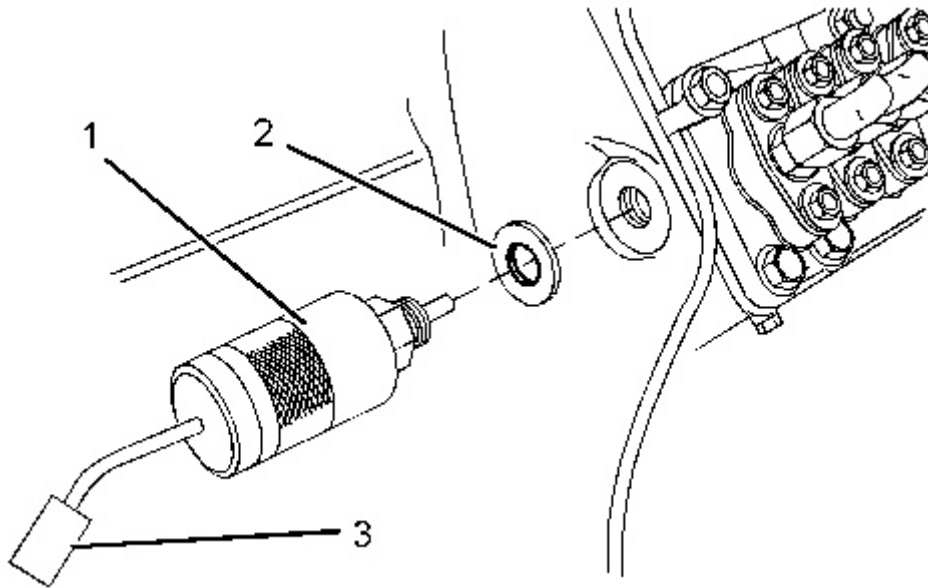

---

Illustration 2

g01326564

Typical example

1. Install sealing washer (2) to fuel shutoff solenoid (1).
  2. Install fuel shutoff solenoid (1) into the fuel injection pump housing by rotating the fuel shutoff solenoid in a clockwise direction. Tighten the fuel shutoff solenoid to a torque of 17 N·m (12 lb ft).
  3. Connect electrical connection (3) to the harness assembly (not shown).
  4. Turn the battery disconnect switch to the ON position.
-

Product: COMPACTOR

Model: CB-32B COMPACTOR 469

Configuration: CB32B Compactor 46900001-UP (MACHINE) POWERED BY C1.5 Electric Power Generation

## **Disassembly and Assembly C1.1, C1.5 and C2.2 Engines for Caterpillar Built Machines**

Media Number -KENR6948-06

Publication Date -01/06/2015

Date Updated -02/08/2018

i07360664

# **Fuel Injection Pump - Remove and Install**

SMCS - 1251-010

## **Removal Procedure**

### **Start By:**

- a. Remove the fuel shutoff solenoid. Refer to Disassembly and Assembly, "Fuel Shutoff Solenoid - Remove and Install".

---

### **NOTICE**

**Care must be taken to ensure that fluids are contained during performance of inspection, maintenance, testing, adjusting and repair of the product. Be prepared to collect the fluid with suitable containers before opening any compartment or disassembling any component containing fluids.**

**Dispose of all fluids according to local regulations and mandates.**

---

---

### **NOTICE**

**Keep all parts clean from contaminants.**

**Contaminants may cause rapid wear and shortened component life.**

---

**Note:** The removal procedure is similar for the three cylinder and the four cylinder engines. The Illustrations show a four cylinder engine.

1. Remove the fuel injection lines. Refer to Disassembly and Assembly, "Fuel Injection Lines - Remove and Install" for more information.

The C1.1 engine has a flexible fuel return hose.

For engines with a flexible fuel return hose, disconnect the fuel hose from the inlet connection of the fuel injection pump.

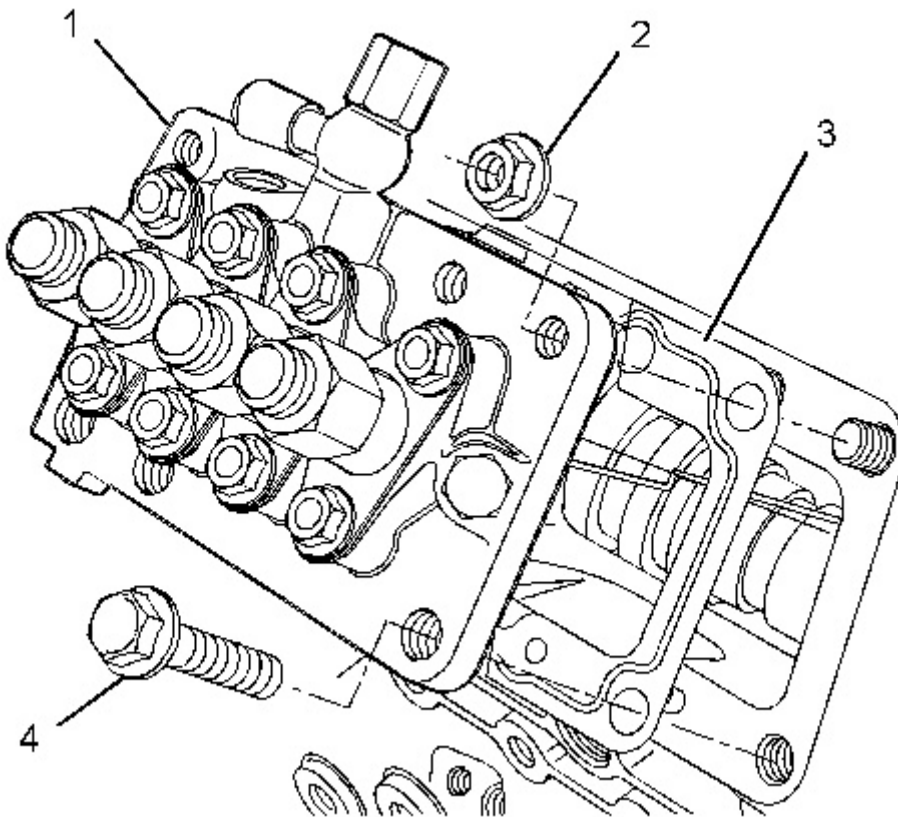

---

Illustration 1  
Typical example

g01327005

---

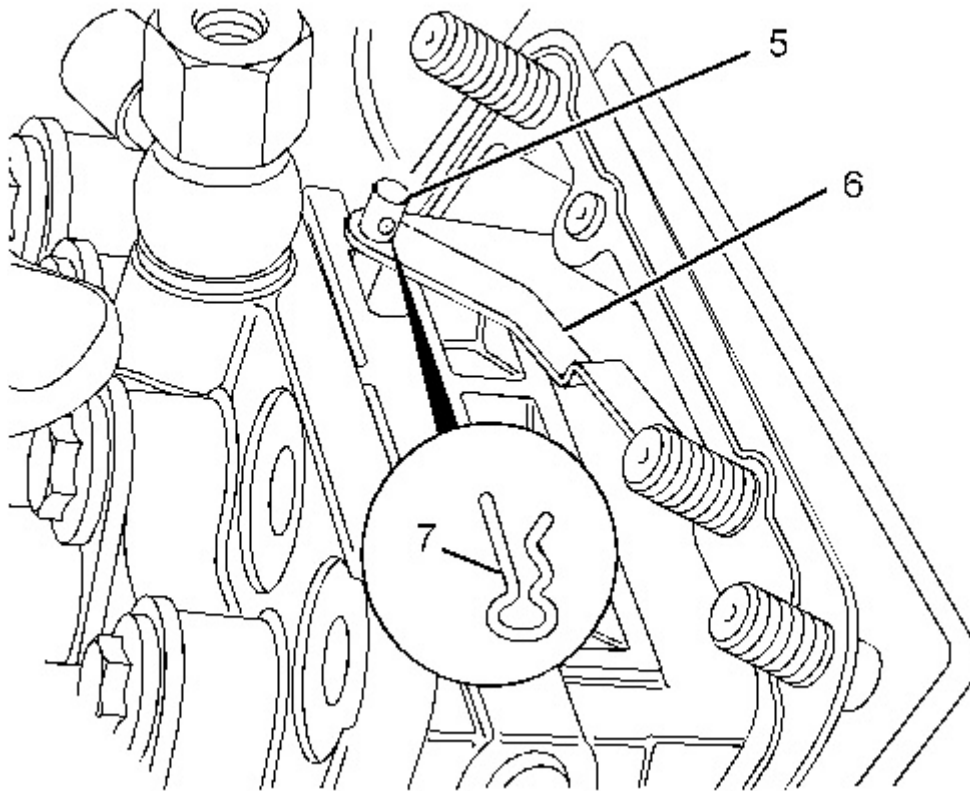

Illustration 2  
Typical example

g01327006

2. Gradually loosen bolts (4) and nuts (2) that fasten the fuel injection pump to the cylinder block.
3. Carefully raise fuel injection pump (1) from the cylinder block and remove clip (7) that connects link (6) to fuel rack control (5).
4. Remove fuel injection pump (1) from the cylinder block.
5. Remove shims (3) from the mounting face of the cylinder block.

**Note:** Record the thickness of each shim and the number of shims for reassembly. The fuel injection timing is determined by the thickness of the shim pack that is between the fuel injection pump and the mounting face on the cylinder block. Refer to Systems Operation, Testing and Adjusting, "Fuel Injection Timing - Check" for more information.

## Installation Procedure

### NOTICE

**Keep all parts clean from contaminants.**

**Contaminants may cause rapid wear and shortened component life.**

---

**Note:** The installation procedure is similar for the three cylinder and the four cylinder engines. The Illustrations show a four cylinder engine.

1. Clean the mating surfaces of the cylinder block and the fuel injection pump.
- 

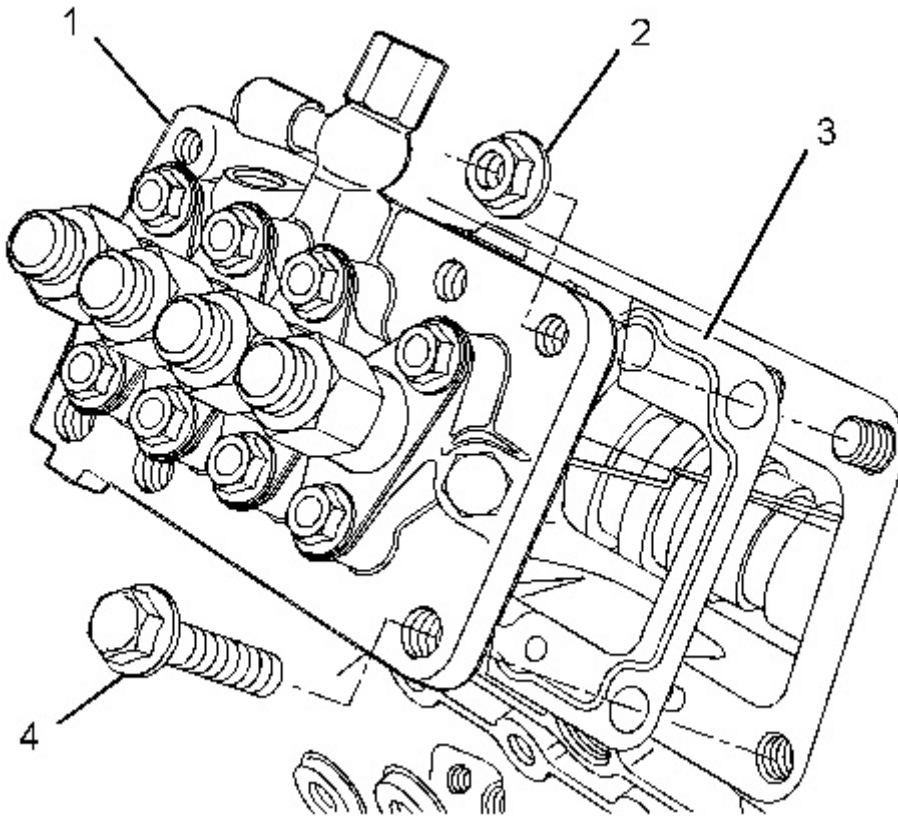

---

Illustration 3  
Typical example

g01327005

2. Install the correct thickness and the correct number of shims (3) on the mounting face of the cylinder block. Refer to Systems Operation, Testing and Adjusting, "Fuel Injection Timing - Check" for more information.
-

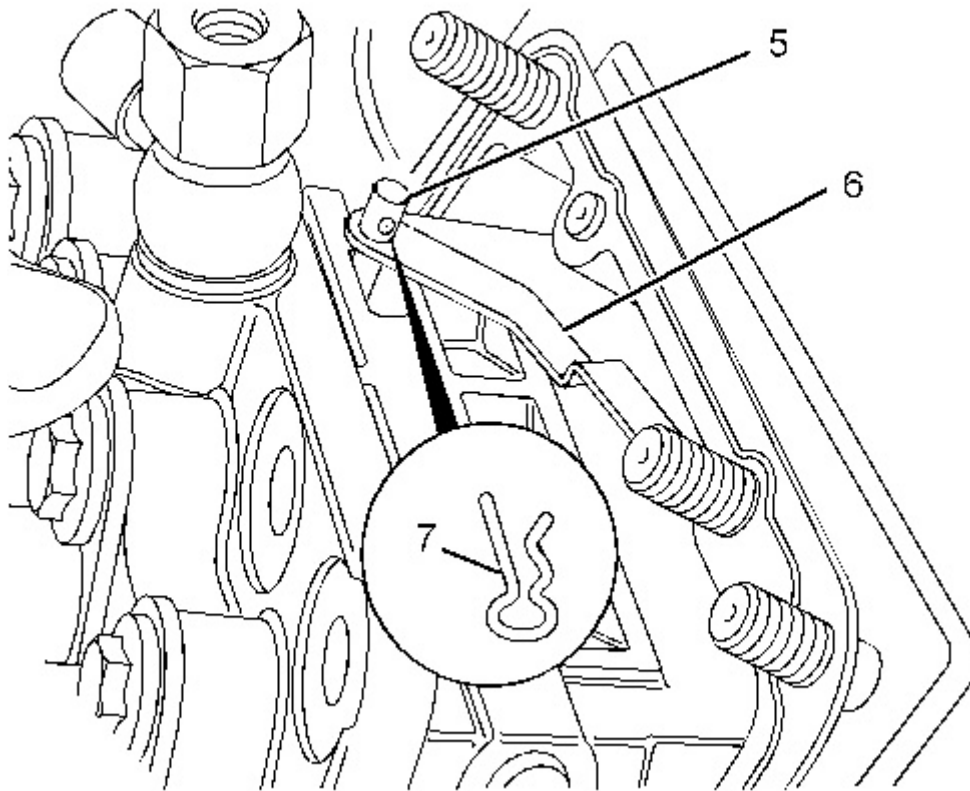

Illustration 4

g01327006

Typical example

3. Position fuel injection pump (1) close to the mounting face of the cylinder block, and connect link (6) and fuel rack control (5) with clip (7).
4. Align fuel injection pump (1) with the studs on the cylinder block. Install the fuel injection pump to the cylinder block.
5. Install bolts (4) and nuts (2). Ensure that the tube clip for the engine oil line is secured by the appropriate fastener.

For the C1.1 engine, evenly tighten bolts (4) and nuts (2) to a torque of 6 N·m (53 lb in).

For C1.5 and C2.2 engines, evenly tighten bolts (4) and nuts (2) to a torque of 15 N·m (133 lb in).

6. Install the fuel injection lines. Refer to Disassembly and Assembly, "Fuel Injection Lines - Remove and Install".

The C1.1 engine has a flexible fuel return hose.

For engines with a flexible fuel return hose, connect the fuel hose to the inlet connection of the fuel injection pump.

**End By:**

- a. Install the fuel shutoff solenoid. Refer to Disassembly and Assembly, "Fuel Shutoff Solenoid - Remove and Install".
-

Product: COMPACTOR

Model: CB-32B COMPACTOR 469

Configuration: CB32B Compactor 46900001-UP (MACHINE) POWERED BY C1.5 Electric Power Generation

## **Disassembly and Assembly C1.1, C1.5 and C2.2 Engines for Caterpillar Built Machines**

Media Number -KENR6948-06

Publication Date -01/06/2015

Date Updated -02/08/2018

i06719926

# **Fuel Injector - Remove and Install**

SMCS - 1290-010

## **Removal Procedure**

### **Start By:**

- a. Remove the fuel injection lines. Refer to Disassembly and Assembly, "Fuel Injection Lines - Remove and Install".

---

### **NOTICE**

**Care must be taken to ensure that fluids are contained during performance of inspection, maintenance, testing, adjusting and repair of the product. Be prepared to collect the fluid with suitable containers before opening any compartment or disassembling any component containing fluids.**

**Dispose of all fluids according to local regulations and mandates.**

---

### **NOTICE**

**Keep all parts clean from contaminants.**

**Contaminants may cause rapid wear and shortened component life.**

---

---



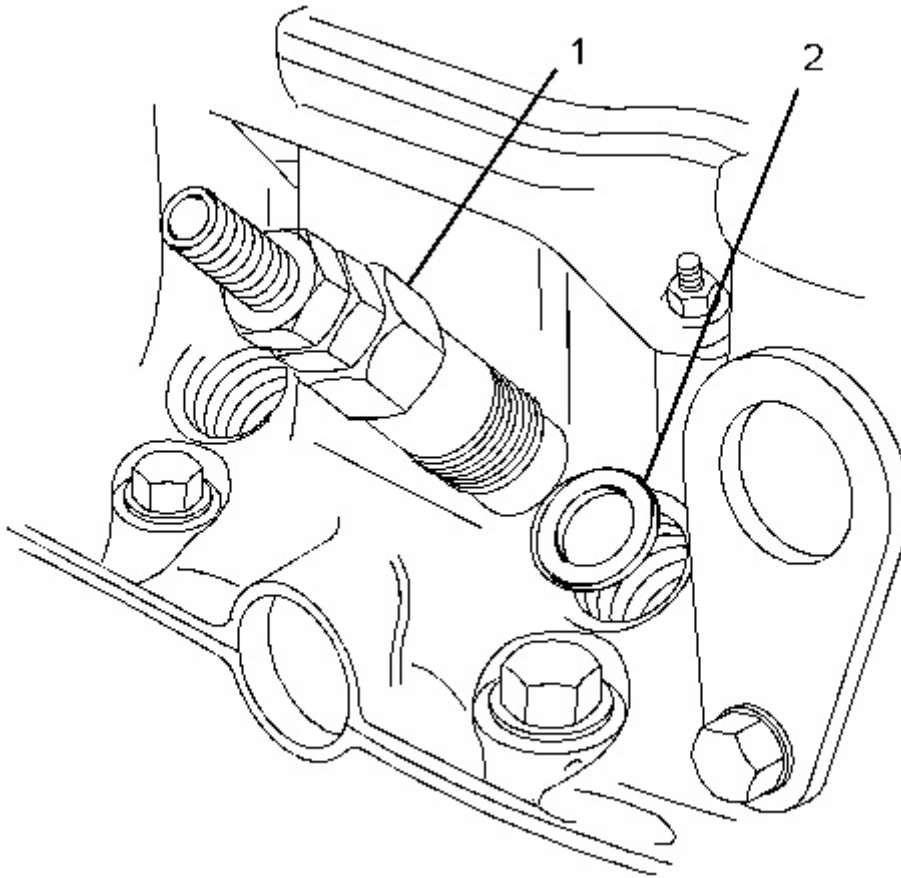

Illustration 1  
Typical example

g01320610

1. Use a deep socket to remove fuel injector (1) from the cylinder head.
2. Remove seat washer (2) from the cylinder head.
3. Cap all openings or plug all openings immediately.

## Installation Procedure

Table 1

Required Tools			
Tool	Part Number	Part Description	Qty
A	239-3312	Sealant	1

### NOTICE

**Keep all parts clean from contaminants.**

**Contaminants may cause rapid wear and shortened component life.**

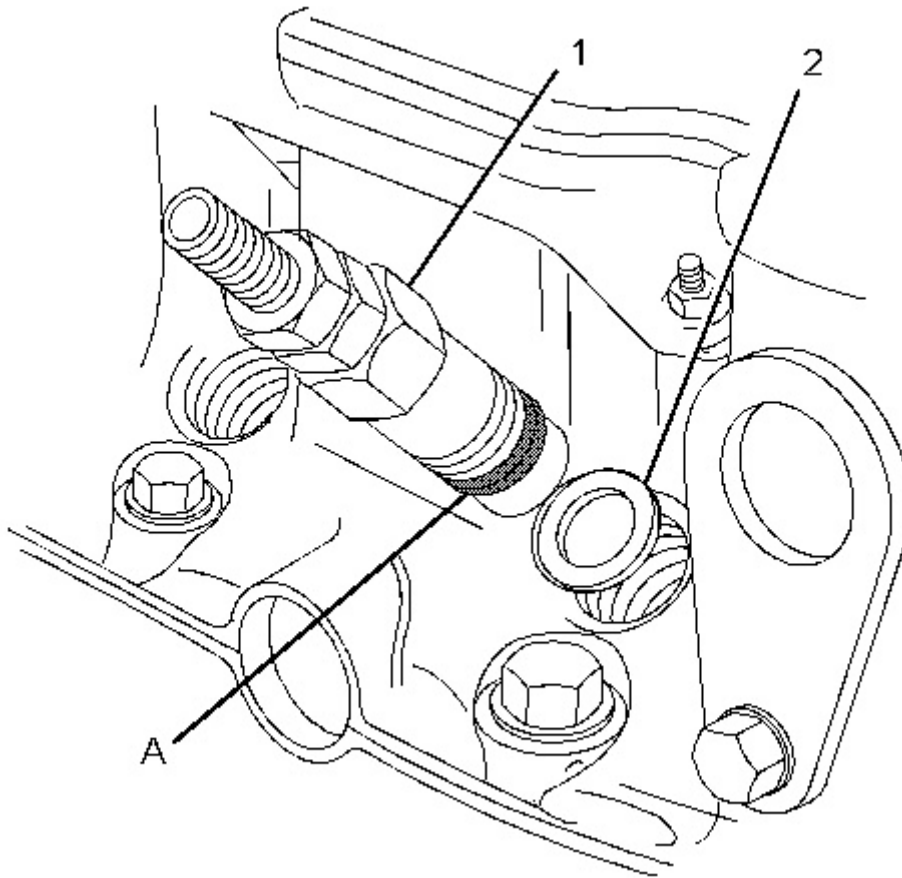

---

Illustration 2

g01304054

Typical example

1. Clean the bore for the fuel injector in the cylinder head. Ensure that no debris enters the cylinder. Clean the threads on the body of the fuel injector.
2. Install new seat washer (2) into the bore for the fuel injector in the cylinder head.
3. Apply a bead of Tooling (A) to the first two threads of the fuel injector that engage into the cylinder head. The bead should have a diameter of 2 mm (0.08 inch) and a length of 6 mm (0.25 inch).

**Note:** Ensure that Tooling (A) does not cover the body of the fuel injector below the threads.

4. Install fuel injector (1) into the cylinder head. Use a deep socket to tighten the fuel injector to a torque of 64 N·m (47 lb ft).

**End By:**

- a. Install the fuel injection lines. Refer to Disassembly and Assembly, "Fuel Injection Lines - Remove and Install".

Product: COMPACTOR

Model: CB-32B COMPACTOR 469

Configuration: CB32B Compactor 46900001-UP (MACHINE) POWERED BY C1.5 Electric Power Generation

## **Disassembly and Assembly C1.1, C1.5 and C2.2 Engines for Caterpillar Built Machines**

Media Number -KENR6948-06

Publication Date -01/06/2015

Date Updated -02/08/2018

i02602655

# **Turbocharger - Remove and Install**

SMCS - 1052-010

## **Removal procedure**

---

### **NOTICE**

**Care must be taken to ensure that fluids are contained during performance of inspection, maintenance, testing, adjusting and repair of the product. Be prepared to collect the fluid with suitable containers before opening any compartment or disassembling any component containing fluids.**

**Dispose of all fluids according to local regulations and mandates.**

---

---

### **NOTICE**

**Keep all parts clean from contaminants.**

**Contaminants may cause rapid wear and shortened component life.**

---

**Note:** Plug and cap all open ports and tube assemblies.

---

Thank you so much for reading.  
Please click the “Buy Now!”  
button below to download the  
complete manual.



After you pay.

You can download the most  
perfect and complete manual in  
the world immediately.

Our support email:

[ebooklibonline@outlook.com](mailto:ebooklibonline@outlook.com)