

Product: VIBRATORY COMPACTOR

Model: CB-334E VIBRATORY COMPACTOR C3A

Configuration: CB-334E CB-334E XW CB-335E Vibratory Compactor C3A00001-UP (MACHINE) POWERED BY 3024C Engine

Disassembly and Assembly 3024C Engine for Caterpillar Built Machines

Media Number -SEN5006-04

Publication Date -01/01/2009

Date Updated -16/01/2009

i04583132

Fuel Injection Pump - Remove

SMCS - 1251-011

Removal Procedure

Start By:

- A. Remove the fuel injection lines. Refer to Disassembly and Assembly, "Fuel Injection Lines - Remove and Install".
- B. If necessary, remove the fuel shutoff solenoid. Refer to Disassembly and Assembly, "Fuel Shutoff Solenoid - Remove and Install".

NOTICE

Keep all parts clean from contaminants.

Contaminants may cause rapid wear and shortened component life.

NOTICE

Care must be taken to ensure that fluids are contained during performance of inspection, maintenance, testing, adjusting, and repair of the product. Be prepared to collect the fluid with suitable containers before opening any compartment or disassembling any component containing fluids.

Refer to Special Publication, NENG2500, "Dealer Service Tool Catalog" for tools and supplies suitable to collect and contain fluids on Cat products.

Dispose of all fluids according to local regulations and mandates.

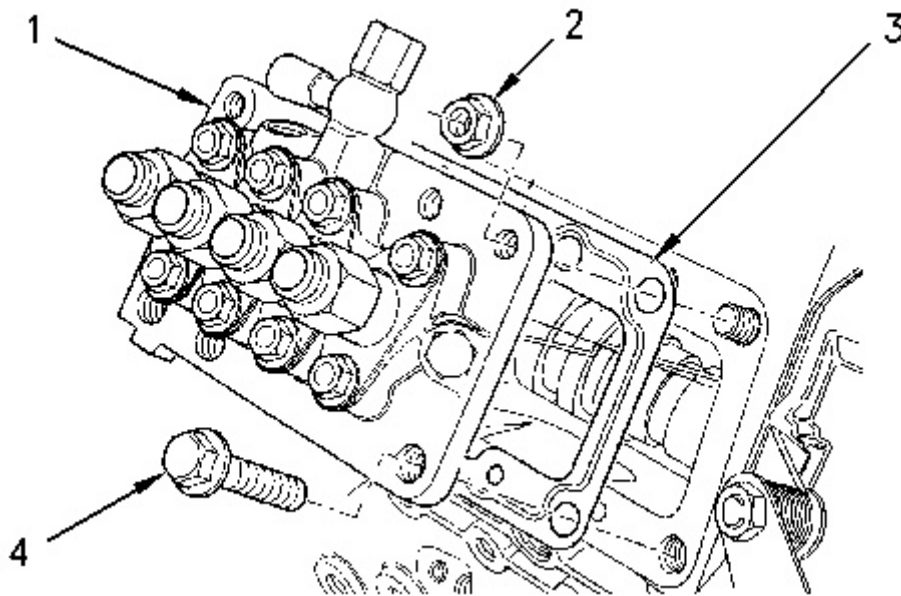

Illustration 1

g00825132

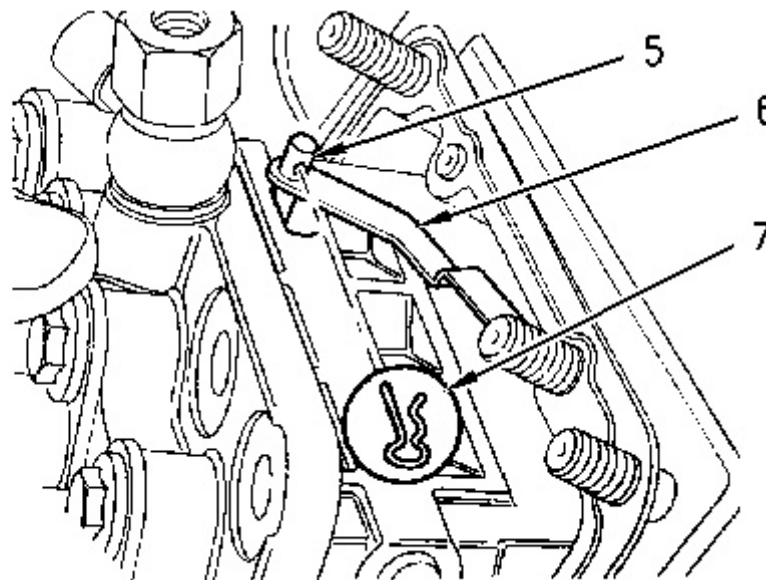

Illustration 2

g00825137

1. Remove bolts (4) and nuts (2) that fasten the fuel injection pump to the cylinder block.
2. Carefully raise fuel injection pump (1) from the cylinder block and remove clip (7) that connects link (6) to fuel rack control (5) .

3. Remove fuel injection pump (1) from the cylinder block.

Note: Record the thickness of each shim and the number of shims for reassembly. The fuel injection timing is determined by the shim pack thickness that is between the fuel injection pump and the mounting face on the cylinder block. For more information on the fuel injection pump, refer to Specifications, "Fuel Injection Pump".

4. Remove shims (3) from the mounting plate.

Product: VIBRATORY COMPACTOR

Model: CB-334E VIBRATORY COMPACTOR C3A

Configuration: CB-334E CB-334E XW CB-335E Vibratory Compactor C3A00001-UP (MACHINE) POWERED BY 3024C Engine

Disassembly and Assembly 3024C Engine for Caterpillar Built Machines

Media Number -SEN5006-04

Publication Date -01/01/2009

Date Updated -16/01/2009

i01892880

Fuel Injection Pump - Install

SMCS - 1251-012

Installation Procedure

NOTICE

Keep all parts clean from contaminants.

Contaminants may cause rapid wear and shortened component life.

NOTICE

Care must be taken to ensure that fluids are contained during performance of inspection, maintenance, testing, adjusting and repair of the product. Be prepared to collect the fluid with suitable containers before opening any compartment or disassembling any component containing fluids.

Refer to Special Publication, NENG2500, "Caterpillar Tools and Shop Products Guide" for tools and supplies suitable to collect and contain fluids on Caterpillar products.

Dispose of all fluids according to local regulations and mandates.

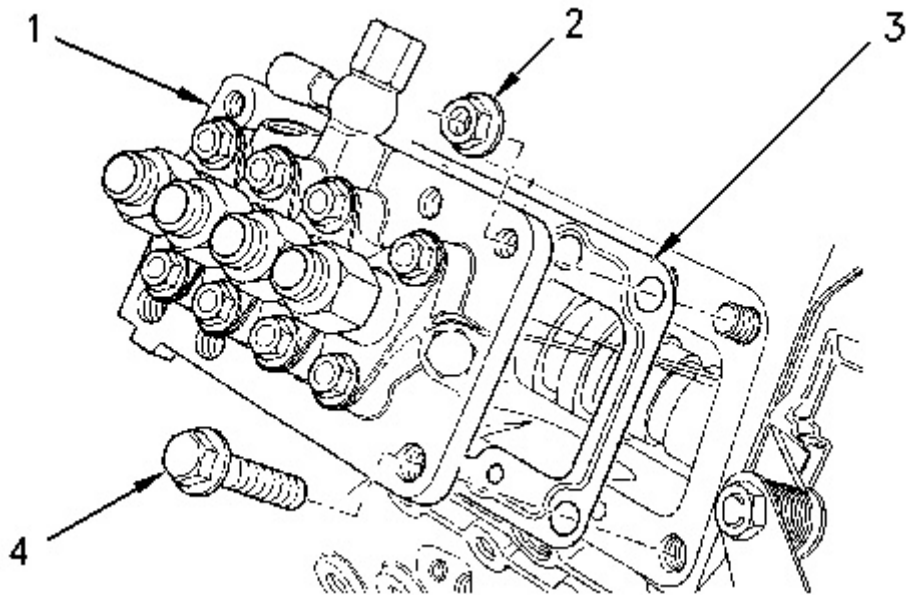

Illustration 1

g00825132

Typical example

1. Position the correct number of shims (3) on the mounting face of the cylinder block. Refer to Specifications, "Fuel Injection Pump".

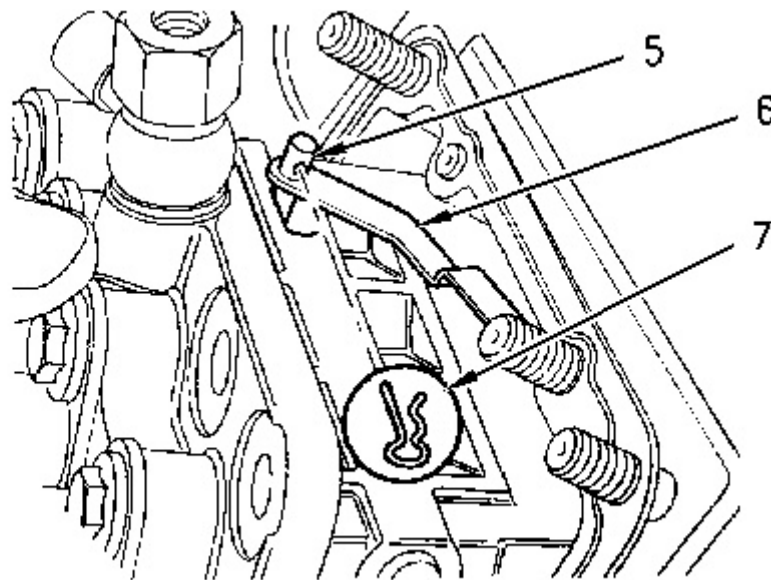

Illustration 2

g00825137

Typical example

2. Position fuel injection pump (1) close to the mounting face of the cylinder block, and connect link (6) and fuel rack control (5) with clip (7) .

3. Put fuel injection pump (1) in position on the mounting face of the cylinder block.
4. Install bolts (4) and nuts (2) that fasten the fuel injection pump to the cylinder block.

For 3013C Engines and 3024C Engines, tighten bolts (4) and nuts (2) to a torque of 15 N·m (11 lb ft).

For 3011C Engines, tighten bolts (4) and nuts (2) to a torque of 6 N·m (53 lb in).

End By:

- a. Install the fuel shutoff solenoid. Refer to Disassembly and Assembly, "Fuel Shutoff Solenoid - Remove and Install".
 - b. Install the fuel injection lines. Refer to Disassembly and Assembly, "Fuel Injection Lines - Remove and Install".
-

Product: VIBRATORY COMPACTOR

Model: CB-334E VIBRATORY COMPACTOR C3A

Configuration: CB-334E CB-334E XW CB-335E Vibratory Compactor C3A00001-UP (MACHINE) POWERED BY 3024C Engine

Disassembly and Assembly 3024C Engine for Caterpillar Built Machines

Media Number -SEN5006-04

Publication Date -01/01/2009

Date Updated -16/01/2009

i01893805

Exhaust Manifold - Remove and Install

SMCS - 1059-010

Removal Procedure

NOTICE

Keep all parts clean from contaminants.

Contaminants may cause rapid wear and shortened component life.

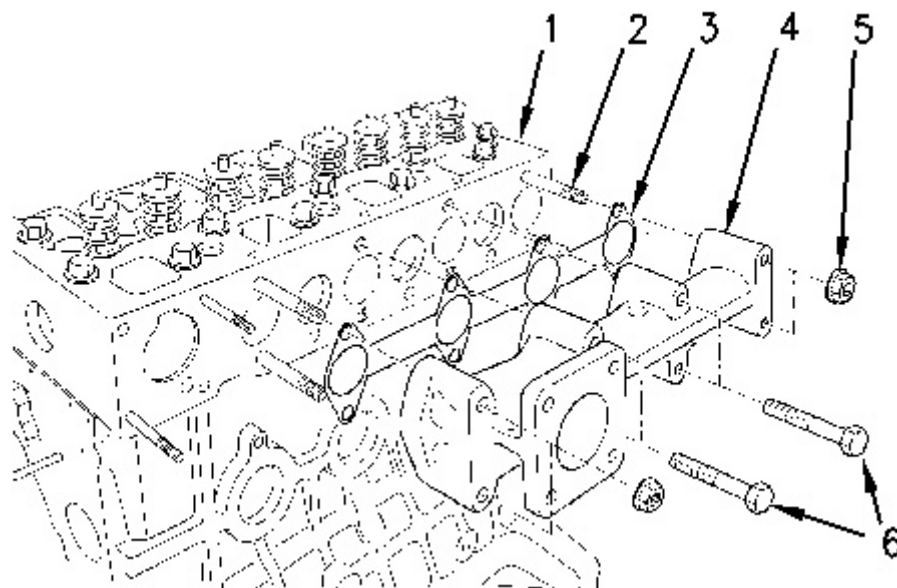

Typical example

1. Remove exhaust manifold nuts (5) and bolts (6) .
2. Remove exhaust manifold (4) from the cylinder head (1) .
3. Remove gasket (3) from the cylinder head.
4. Remove any remaining gasket material and carbon from the cylinder head and the exhaust manifold. Be careful not to damage the mating surface on the cylinder head for the exhaust manifold.
5. Remove studs (2) for exhaust manifold (4) from cylinder head (1) .

Installation Procedure

NOTICE

Keep all parts clean from contaminants.

Contaminants may cause rapid wear and shortened component life.

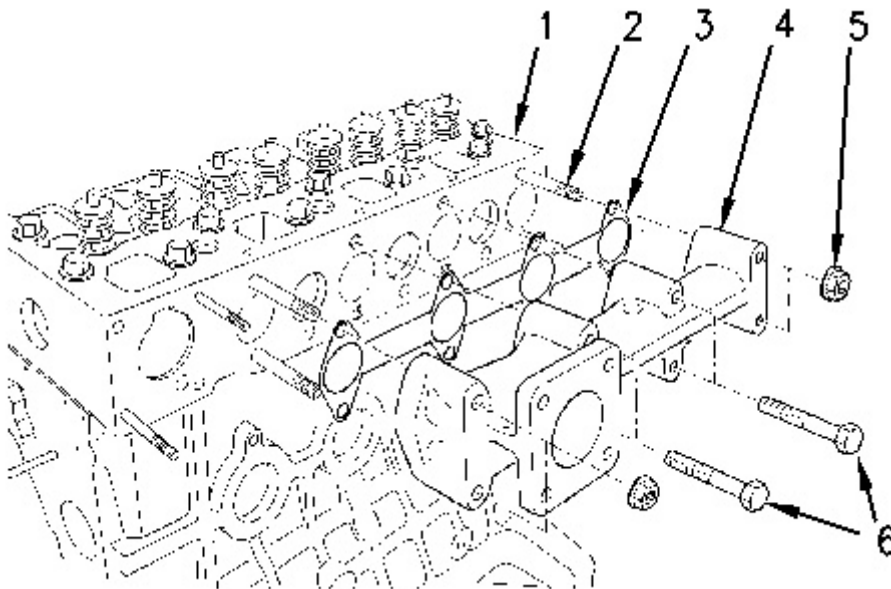

Typical example

1. If studs (2) were removed during disassembly, install attaching studs (2) to cylinder head (1) .
2. Put a new exhaust manifold gasket (3) in position on cylinder head (1) .

Note: Do not use any sealant on the exhaust manifold gasket.

3. Put exhaust manifold (4) in position on cylinder head (1) .
4. Install exhaust manifold nuts (5) and bolts (6) .

For 3013C Engines and 3024C Engines, tighten nuts (5) and bolts (6) to a torque of 25 N·m (18 lb ft).

For 3011C Engines, tighten nuts (5) and bolts (6) to a torque of 10 N·m (89 lb in).

Note: Tighten the two inner bolts first on three cylinder engines. Tighten the four inner bolts first on four cylinder engines. Then tighten the two outer bolts and the two nuts. Ensure that the bolts with different lengths are installed in the correct holes.

Product: VIBRATORY COMPACTOR

Model: CB-334E VIBRATORY COMPACTOR C3A

Configuration: CB-334E CB-334E XW CB-335E Vibratory Compactor C3A00001-UP (MACHINE) POWERED BY 3024C Engine

Disassembly and Assembly 3024C Engine for Caterpillar Built Machines

Media Number -SEN5006-04

Publication Date -01/01/2009

Date Updated -16/01/2009

i02399171

Inlet and Exhaust Valve Springs - Remove and Install

SMCS - 1108-010

Removal Procedure

Table 1

Required Tools			
Tool	Part Number	Part Description	Qty
A	9U-6195	Valve Spring Compressor	1

Start By:

- A. Remove the rocker shaft. Refer to Disassembly and Assembly, "Rocker Shaft and Pushrod - Remove".

NOTICE

Keep all parts clean from contaminants.

Contaminants may cause rapid wear and shortened component life.

Note: Before you begin the removal of the valve springs, refer to Specifications, "Cylinder Head Valves" and Testing and Adjusting, "Cylinder Head - Inspect" for appropriate information on the valve springs.

NOTICE

Do not turn the crankshaft while the valve springs are removed.

-
1. Ensure that the piston is at the top center position.
-

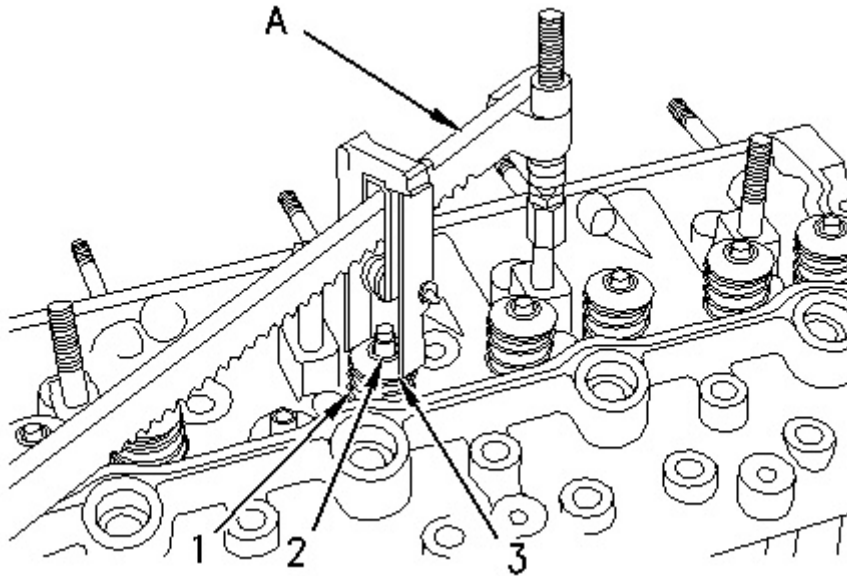

Illustration 1

g00825744

! WARNING

Personal injury can result from parts and/or covers under spring pressure.

Spring force will be released when covers are removed.

Be prepared to hold spring loaded covers as the bolts are loosened.

2. Use Tooling (A) to compress valve springs (1) . Remove valve keepers (2) .
-

NOTICE

Ensure that the valve spring is compressed squarely or damage to the valve stem may occur.

3. Release the pressure on Tooling (A) . Remove valve spring retainer (3) and valve springs (1) from the cylinder head.

NOTICE

Do not turn the crankshaft while the valve springs are removed.

Installation Procedure

Table 2

Required Tools			
Tool	Part Number	Part Description	Qty
A	9U-6195	Valve Spring Compressor	1

NOTICE

Keep all parts clean from contaminants.

Contaminants may cause rapid wear and shortened component life.

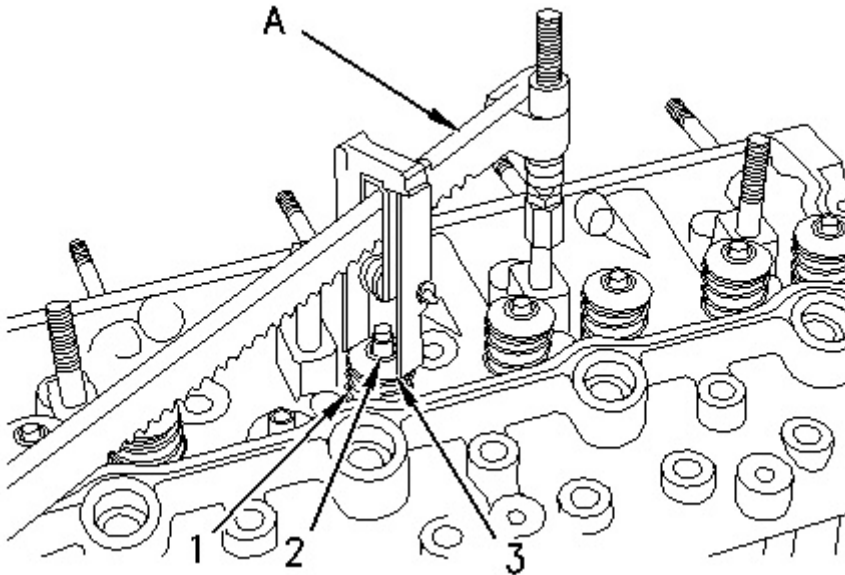

Illustration 2

g00825744



Improper assembly of parts that are spring loaded can cause bodily injury.

To prevent possible injury, follow the established assembly procedure and wear protective equipment.

1. Place new valve springs (1) into position on the cylinder head.

Note: Ensure that the closed damper coils are toward the cylinder head if double valve springs are used.

2. Install valve spring retainer (3) .
3. Use Tooling (A) to compress valve springs (1) .

NOTICE

Ensure that the valve spring is compressed squarely or damage to the valve stem may occur.

4. Install valve keepers (2) in order to lock the valve springs in position.
5. Release the pressure slowly on Tooling (A) . Remove Tooling (A) . Strike the top of the valves with a soft faced hammer in order to ensure that the valve keepers are properly installed.

End By: Install the rocker shaft. Refer to Disassembly and Assembly, "Rocker Shaft and Pushrod - Install".

Product: VIBRATORY COMPACTOR

Model: CB-334E VIBRATORY COMPACTOR C3A

Configuration: CB-334E CB-334E XW CB-335E Vibratory Compactor C3A00001-UP (MACHINE) POWERED BY 3024C Engine

Disassembly and Assembly 3024C Engine for Caterpillar Built Machines

Media Number -SEN5006-04

Publication Date -01/01/2009

Date Updated -16/01/2009

i02015360

Inlet and Exhaust Valves - Remove and Install

SMCS - 1105-010

Removal Procedure

Table 1

Required Tools			
Tool	Part Number	Part Description	Qty
A	9U-6195	Valve Spring Compressor	1

Start By:

- A. Remove the cylinder head. Refer to Disassembly and Assembly, "Cylinder Head - Remove".

NOTICE

Keep all parts clean from contaminants.

Contaminants may cause rapid wear and shortened component life.

1. Clean the bottom face of the cylinder head. Use a dial indicator to check the depth of the valves below the face of the cylinder head before the valve springs are removed. Refer to the Specifications, "Cylinder Head Valves" for the correct dimensions.
 2. Place an index mark on the heads of the inlet valves and the exhaust valves for installation purposes.
-

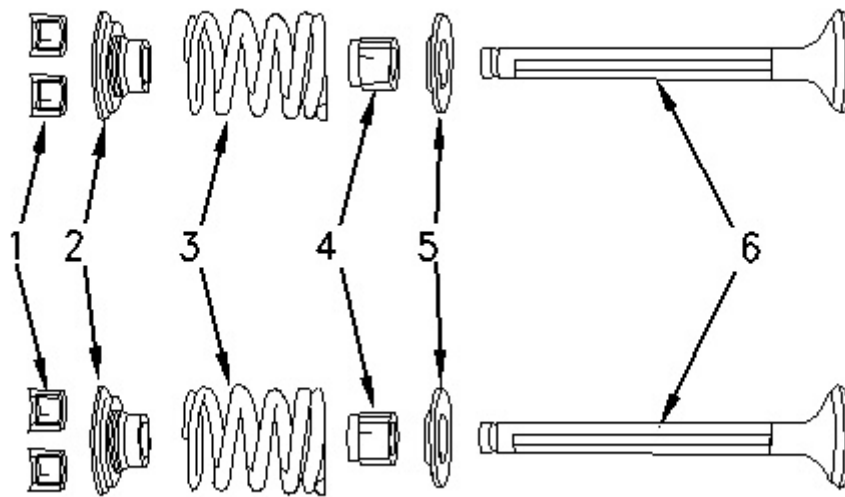

Illustration 1

g00659252

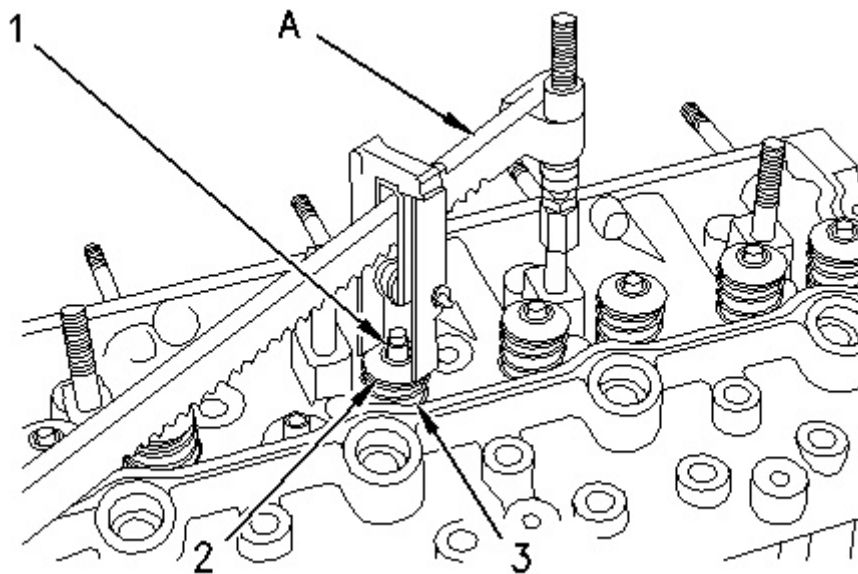

Illustration 2

g00825746

⚠ WARNING

The valve spring keepers can be thrown from the valve when the valve spring compressor is released. Ensure that the valve spring keepers are properly installed on the valve stem. To help prevent personal injury, keep away from the front of the valve spring keepers and valve springs during the installation of the valves.

3. Use Tooling (A) to compress valve springs (3) .
4. Remove two valve keepers (1) .
5. Slowly release the pressure on Tooling (A) and remove Tooling (A) .
6. Remove valve spring retainers (2) .
7. Remove valve springs (3) .
8. Remove valve stem seals (4) .
9. Remove valve spring seat washers (5) .
10. Remove inlet valves (6) and exhaust valves (6) .

Removal Procedure (Alternate Method)

Table 2

Required Tools			
Tool	Part Number	Part Description	Qty
B	5S-1330	Valve Spring Compressor	1

Follow the instructions above using Tooling (B) .

Installation Procedure

Table 3

Required Tools			
Tool	Part Number	Part Description	Qty
A	9U-6195	Valve Spring Compressor	1

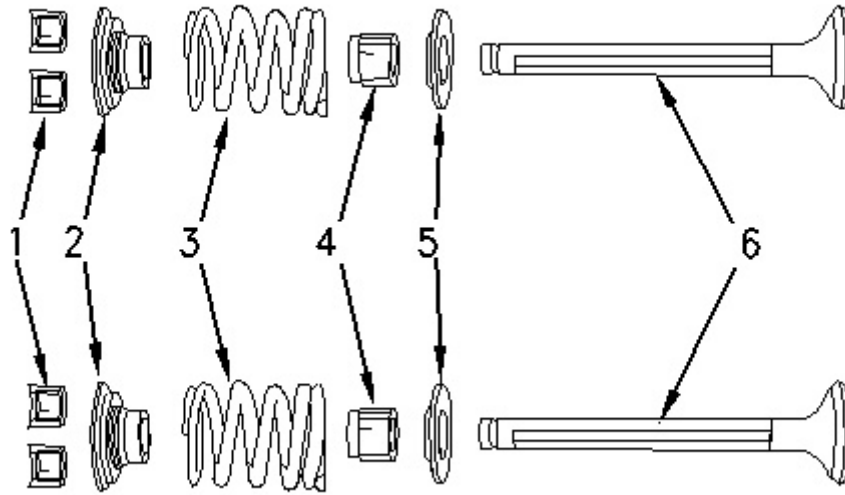

Illustration 3

g00659252

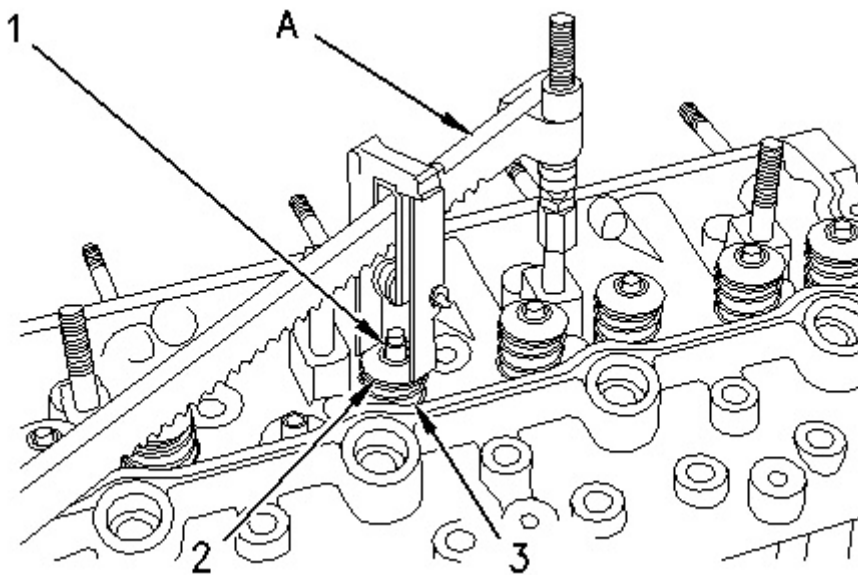

Illustration 4

g00825746

NOTICE

Keep all parts clean from contaminants.

Contaminants may cause rapid wear and shortened component life.

WARNING

The valve spring keepers can be thrown from the valve when the valve spring compressor is released. Ensure that the valve spring keepers are properly installed on the valve stem. To help prevent personal injury, keep away from the front of the valve spring keepers and valve springs during the installation of the valves.

1. Lubricate the stems of inlet valves (6) and the stems of exhaust valves (6) with clean engine oil.
2. Install inlet valves (6) and exhaust valves (6) in the respective positions.
3. Install valve spring seat washers (5) .
4. Install new valve stem seals (4) .
5. Install valve springs (3) .

Note: Install valve springs (3) on the valve spring seat washers. This is done with double valve springs.

6. Install valve spring retainers (2) .
7. Use Tooling (A) to compress valve springs (3) .
8. Install valve keepers (1) .
9. Slowly release the pressure on Tooling (A) and remove Tooling (A). Strike the top of the valves with a soft hammer in order to ensure that the valve keepers are properly installed.

Note: Refer to Specifications, "Cylinder Head Valves" for more information on the inlet valves and the exhaust valves.

10. Use a dial indicator to check the depth of the new valves below the cylinder head. If the depth of the new valves is below the correct depth, the valve seat inserts must be replaced.

End By: Install the cylinder head. Refer to Disassembly and Assembly, "Cylinder Head - Install".

Installation Procedure (Alternate Method)

Table 4

Required Tools			
Tool	Part Number	Part Description	Qty
B	5S-1330	Valve Spring Compressor	1

Follow the procedure above using Tooling (B).

Product: VIBRATORY COMPACTOR

Model: CB-334E VIBRATORY COMPACTOR C3A

Configuration: CB-334E CB-334E XW CB-335E Vibratory Compactor C3A00001-UP (MACHINE) POWERED BY 3024C Engine

Disassembly and Assembly 3024C Engine for Caterpillar Built Machines

Media Number -SEN5006-04

Publication Date -01/01/2009

Date Updated -16/01/2009

i01787732

Engine Oil Line - Remove and Install

SMCS - 1307-010

Removal Procedure

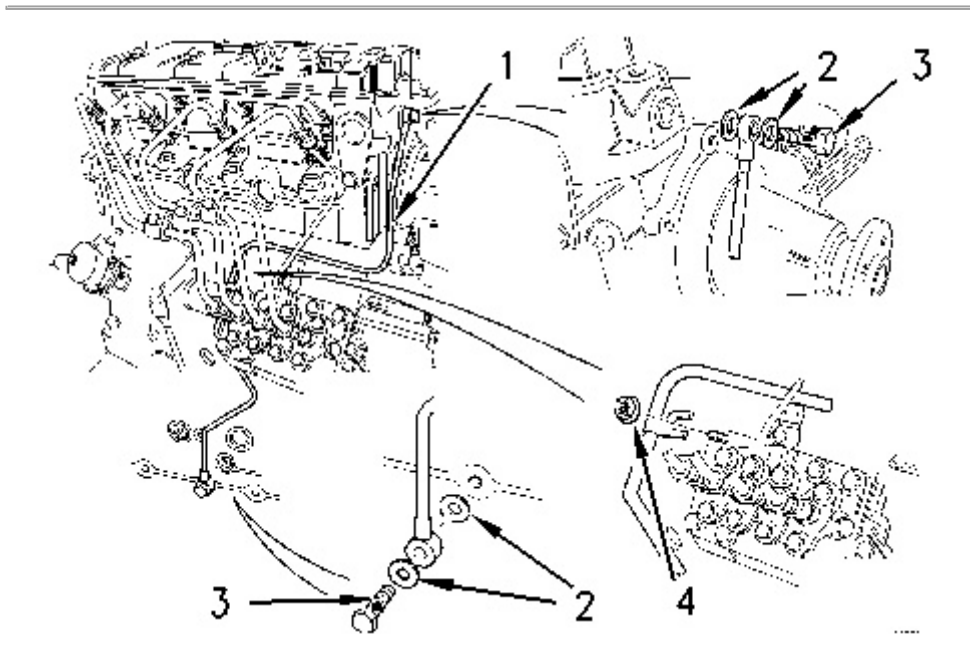

Illustration 1

g00827402

Typical example

1. Loosen nut (4) that attaches oil line (1) to the cylinder block.
2. Remove banjo bolt (3) and remove washers (2) from the cylinder block.
3. Remove banjo bolt (3) and remove washers (2) from the cylinder head. Discard washers (2).

4. Remove oil line (1) from the engine.

Installation Procedure

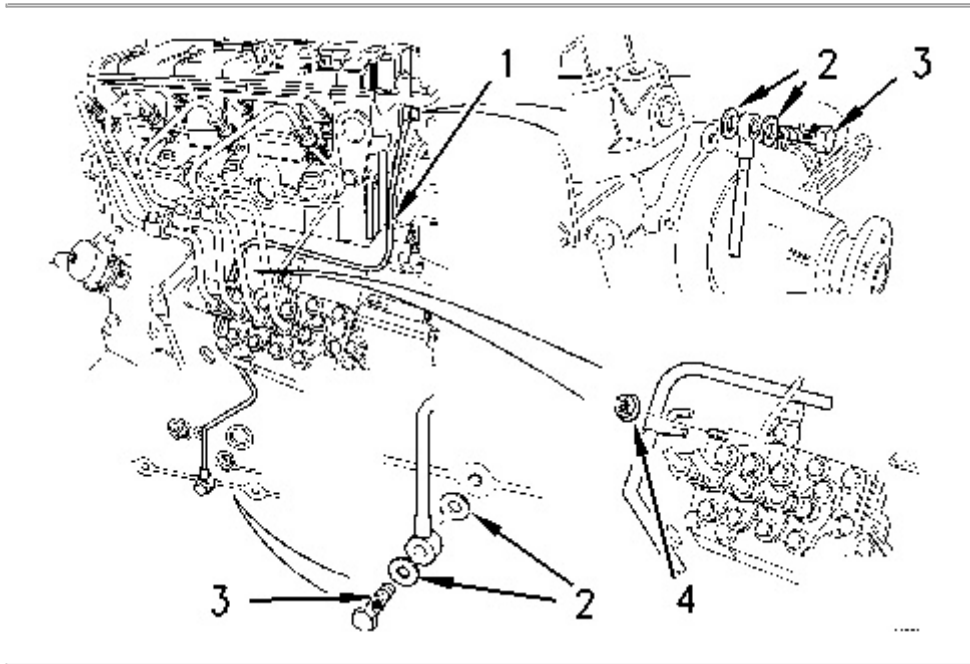

Illustration 2

g00827402

Typical example

1. Position oil line (1) on the engine.
 2. Position banjo bolt (3) and new washers (2) on oil line (1). Install the oil line to the cylinder block.
 3. Position banjo bolt (3) and washers (2) to oil line (1). Install the oil line to the cylinder head.
 4. Tighten nut (4) that attaches oil line (1) to the cylinder block.
 5. Tighten banjo bolts (3) to 12 N·m (9 lb ft).
-

Thank you so much for reading.
Please click the “Buy Now!”
button below to download the
complete manual.



After you pay.

You can download the most
perfect and complete manual in
the world immediately.

Our support email:

ebooklibonline@outlook.com