

Product: VIBRATORY COMPACTOR

Model: CB-564D VIBRATORY COMPACTOR C6D

Configuration: CB-564D Vibratory Compactor C6D00001-UP (MACHINE) POWERED BY 3054C Engine

Disassembly and Assembly 3054C Engines for Caterpillar Built Machines

Media Number -SEN5069-18

Publication Date -01/05/2015

Date Updated -19/09/2018

i01875845

Idler Gear - Remove and Install - Delphi DP210 Fuel Injection Pump

SMCS - 1206

Removal Procedure

Table 1

Required Tools			
Tool	Part Number	Part Name	Qty
A	9U-6198	Crankshaft Turning Tool	1
B	230-6284	Timing Pin (Camshaft)	1
C	230-6283	Timing Pin (Crankshaft)	1
D	1P-2320	Combination Puller	1
E	1P-0510	Driver Group	1

Start By:

- a. Remove the crankshaft pulley. Refer to Disassembly and Assembly, "Crankshaft Pulley - Remove and Install".
- b. Remove the front cover. Refer to Disassembly and Assembly, "Front Cover - Remove and Install".

NOTICE

Keep all parts clean from contaminants.

Contaminants may cause rapid wear and shortened component life.

NOTICE

Care must be taken to ensure that fluids are contained during performance of inspection, maintenance, testing, adjusting, and repair of the product. Be prepared to collect the fluid with suitable containers before opening any compartment or disassembling any component containing fluids.

Refer to Special Publication, NENG2500, "Dealer Service Tool Catalog" for tools and supplies suitable to collect and contain fluids on Cat products.

Dispose of all fluids according to local regulations and mandates.

1. Use Tooling (A) to ensure that the No. 1 cylinder is at the top center compression stroke. Refer to Testing and Adjusting, "Finding Top Center Position for No. 1 Piston".

Note: Install Tooling (B) through the camshaft gear. Install Tooling (C) into the crankshaft web.

NOTICE

The valve timing and the fuel injection pump timing will be lost if the crankshaft is rotated when the idler gear is removed.

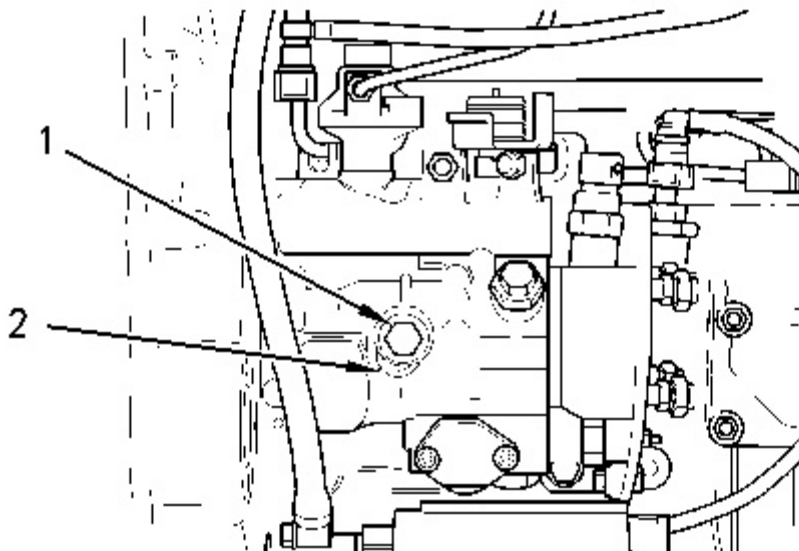

2. Loosen bolt (1). Move spacer (2) in order to allow bolt (1) to tighten against the shaft of the fuel injection pump. Rotate and hold the fuel injection pump gear in a counterclockwise direction in order to remove the backlash. Tighten bolt (1) to a torque of 17 N·m (13 lb ft).

Note: Bolt (1) must be tightened in order to prevent the shaft of the fuel injection pump from rotating.

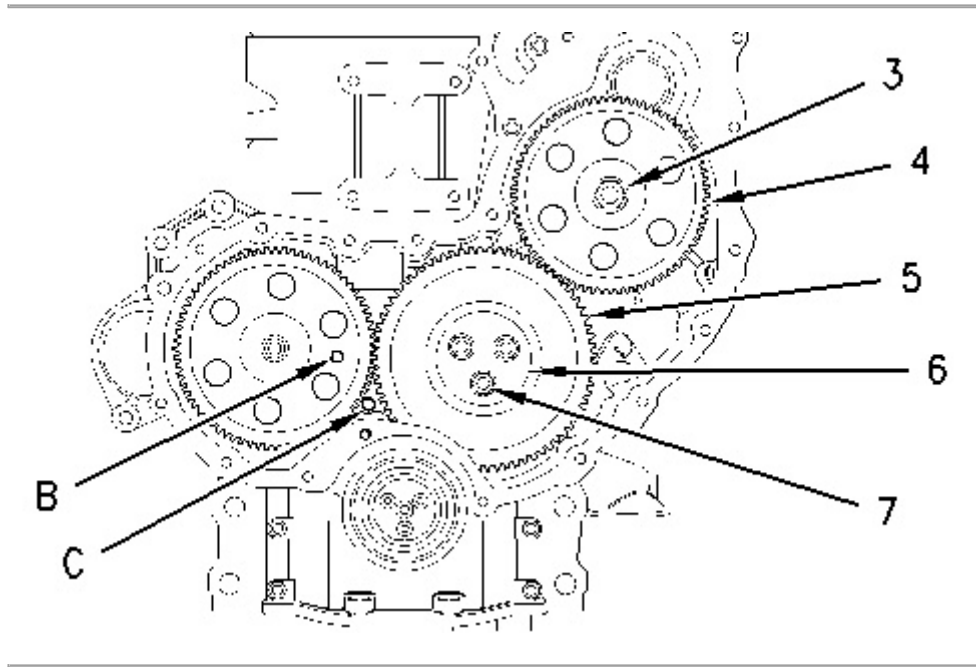

3. Remove nut (3) and the washer from the shaft of the fuel injection pump.
4. Install Tooling (D) and remove fuel injection pump gear (4).

Note: Do Not pry the fuel injection pump gear from the shaft of the fuel injection pump.

5. Remove bolts (7) and retaining plate (6).
-

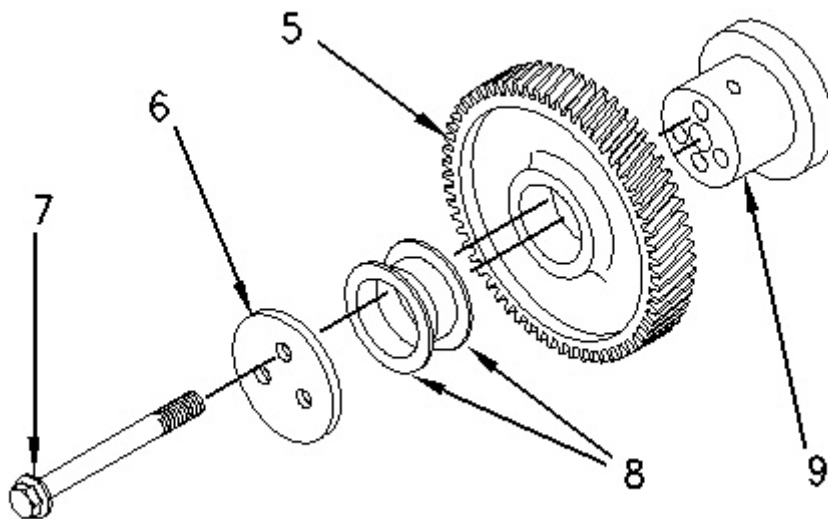

Illustration 3

g00992822

6. Remove idler gear (5) and idler gear hub (9).
7. Use Tooling (E) and remove bushings (8) from each side of the idler gear.

Installation Procedure

Table 2

A	9U-6198	Crankshaft Turning Tool	1
B	230-6284	Timing Pin (Camshaft)	1
C	230-6283	Timing Pin (Crankshaft)	1
E	1P-0510	Driver Group	1

NOTICE

Keep all parts clean from contaminants.

Contaminants may cause rapid wear and shortened component life.

1. Use Tooling (A) to ensure that the No. 1 cylinder is at the top center compression stroke. Refer to Testing and Adjusting, "Finding Top Center Position for No. 1 Piston".

Note: Install Tooling (B) through the camshaft gear. Install Tooling (C) into the crankshaft web.

NOTICE

The valve timing and the fuel injection pump timing will be lost if the crankshaft is rotated when the idler gear is removed.

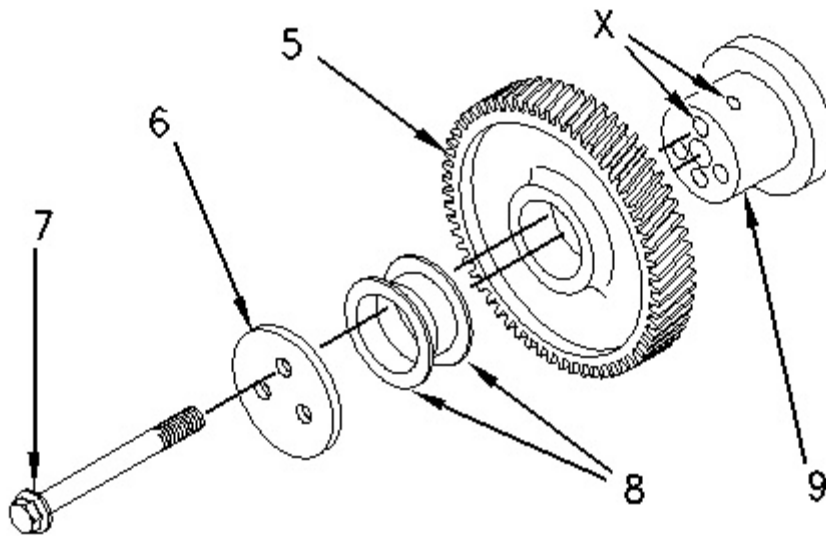

Illustration 4

g00943872

2. Position idler gear hub (9) and install bolts (7) in order to locate the idler gear hub. Tighten the bolts in order to seat the idler gear hub.

Note: The Lubrication Hole (X) of the idler gear hub must be positioned at the top of the idler gear hub.

3. Use a suitable press and Tooling (E) to install bushings (8) on each side of idler gear (5).
4. Remove bolts (7) from the idler gear hub. Install idler gear (5) on idler gear hub (9).

Note: When you install the idler gear, ensure that the marked teeth are facing toward the front.

5. Install retainer plate (6) and bolts (7). Tighten the bolts to a torque of 44 N·m (32 lb ft).
-

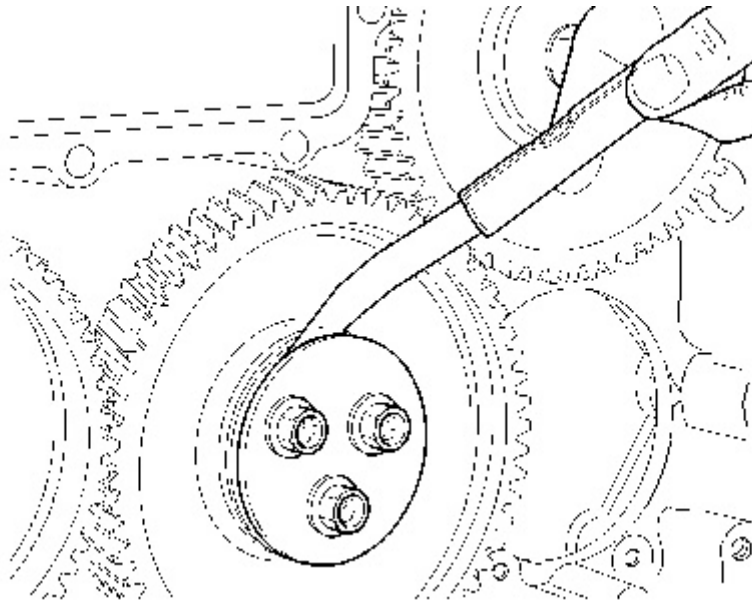

Illustration 5

g00944081

6. Check the end play for the idler gear. The end play for the idler gear is 0.10 to 0.20 mm (0.004 to 0.008 inch).

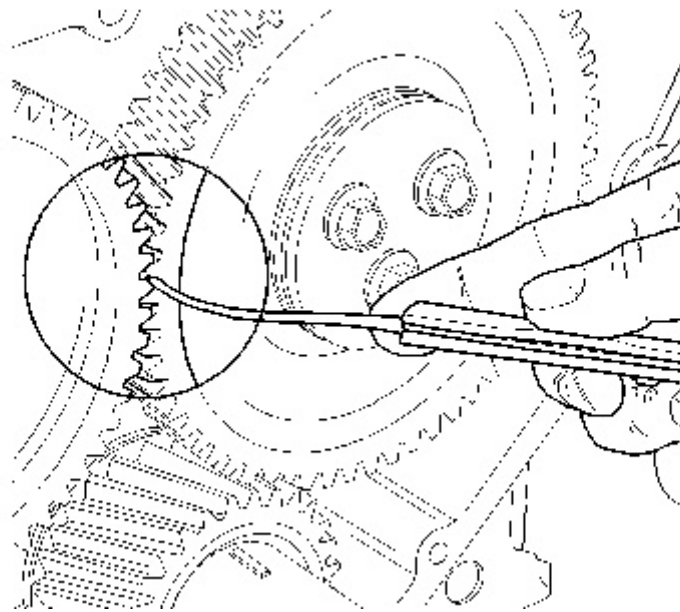

Illustration 6

g00944084

7. Check the backlash between the idler gear and the camshaft gear. The backlash for the gears is 0.052 to 0.107 mm (0.0020 to 0.0042 inch).
8. Check the backlash between the idler gear and the crankshaft gear. The backlash for the gears is 0.064 to 0.124 mm (0.0025 to 0.0049 inch).

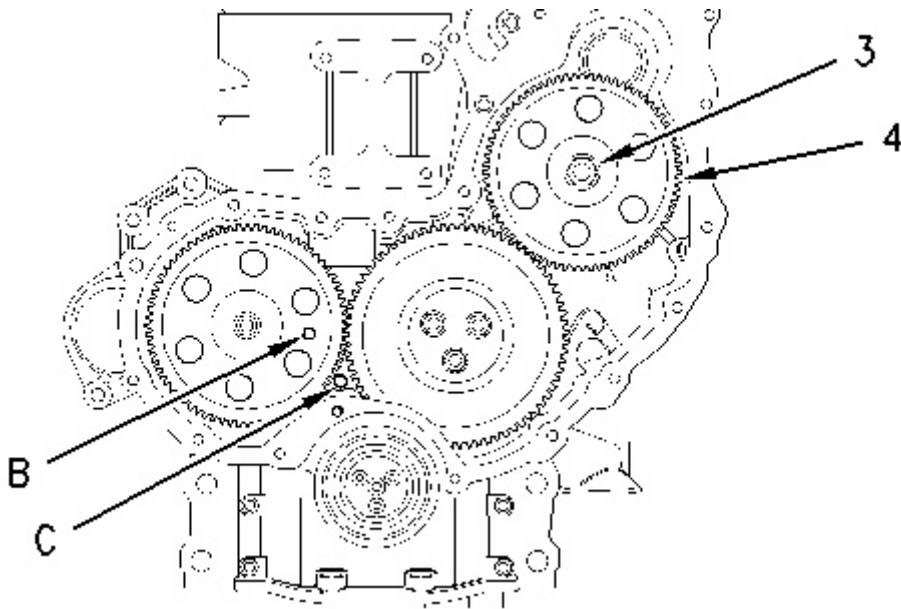

Illustration 7

g00992853

Note: Ensure that the mating surfaces of the fuel injection pump gear and the shaft of the fuel injection pump are clean. Lubricate the threads of the shaft for the fuel injection pump. The nut must turn freely until contact is made with the fuel injection pump gear.

9. Position fuel injection pump gear (4) on the shaft of the fuel injection pump. Rotate the fuel injection pump gear in a counterclockwise direction in order to remove the backlash. Install the washer and nut (3). Tighten the nut to a torque of 24 N·m (17 lb ft).

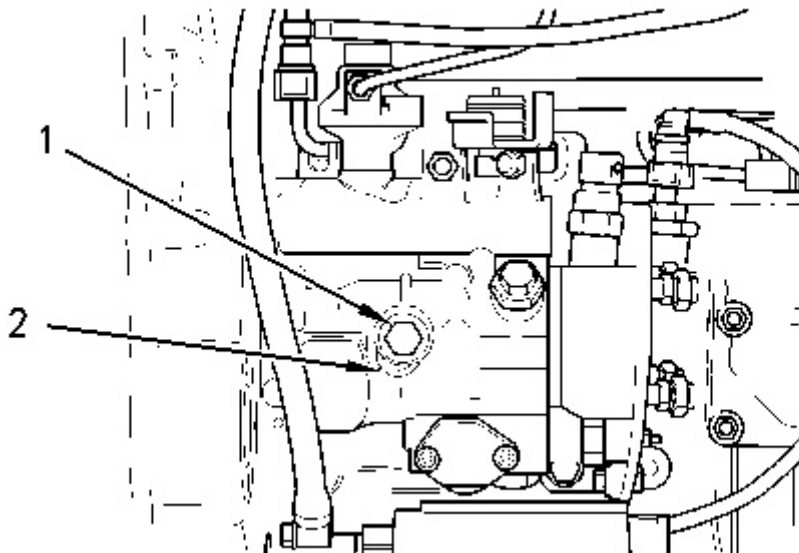

Illustration 8

g00992803

10. Loosen bolt (1). Move spacer (2) in order to prevent bolt (1) from tightening against the shaft of the fuel injection pump. Tighten bolt (1) to a torque of 12 N·m (106 lb in).

Note: Spacer (2) must be correctly positioned and bolt (1) must be tightened in order to prevent the bolt from contacting the shaft of the fuel injection pump.

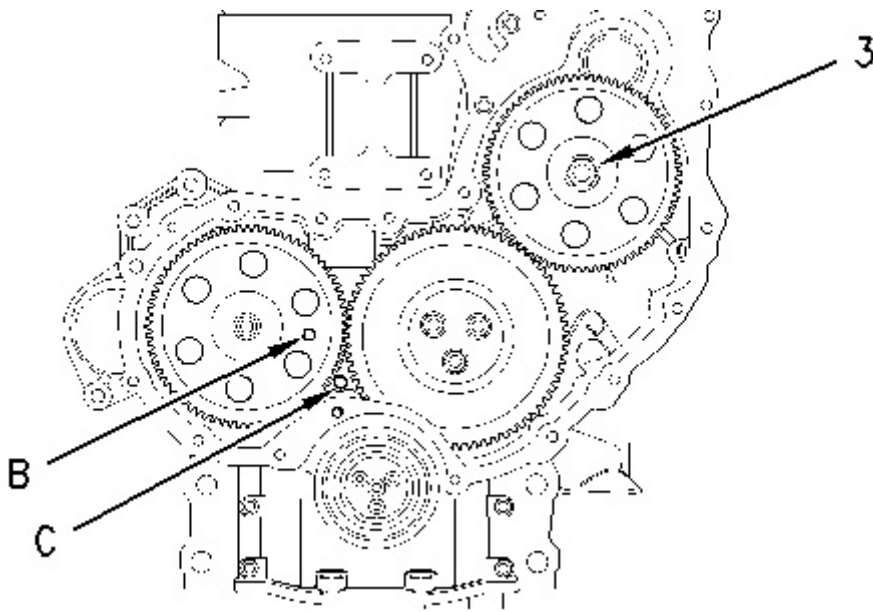

Illustration 9

g00992883

11. Tighten nut (3) to a torque of 88 N·m (65 lb ft).
12. Remove Tooling (B) and Tooling (C).

End By:

- a. Install the front cover. Refer to Disassembly and Assembly, "Front Cover - Remove and Install".
 - b. Install the crankshaft pulley. Refer to Disassembly and Assembly, "Crankshaft Pulley - Remove and Install".
-

Product: VIBRATORY COMPACTOR

Model: CB-564D VIBRATORY COMPACTOR C6D

Configuration: CB-564D Vibratory Compactor C6D00001-UP (MACHINE) POWERED BY 3054C Engine

Disassembly and Assembly 3054C Engines for Caterpillar Built Machines

Media Number -SEN5069-18

Publication Date -01/05/2015

Date Updated -19/09/2018

i05324845

Housing (Front) - Remove

SMCS - 1151-011

Removal Procedure

Start By:

- a. Remove the alternator. Refer to Disassembly and Assembly, "Alternator - Remove".
- b. Remove the crankshaft pulley. Refer to Disassembly and Assembly, "Crankshaft Pulley - Remove and Install".
- c. Remove the front cover. Refer to Disassembly and Assembly, "Front Cover - Remove and Install".
- d. Remove the engine oil pan. Refer to Disassembly and Assembly, "Engine Oil Pan - Remove and Install".
- e. Remove the idler gear. Refer to Disassembly and Assembly, "Idler Gear - Remove and Install".
- f. Remove the camshaft gear. Refer to Disassembly and Assembly, "Camshaft Gear - Remove and Install".
- g. Remove the air compressor, if equipped. Refer to Disassembly and Assembly, "Air Compressor - Remove and Install".

NOTICE

Keep all parts clean from contaminants.

Contaminants may cause rapid wear and shortened component life.

NOTICE

Care must be taken to ensure that fluids are contained during performance of inspection, maintenance, testing, adjusting, and repair of the product. Be prepared to collect the fluid with suitable containers before opening any compartment or disassembling any component containing fluids.

Refer to Special Publication, NENG2500, "Dealer Service Tool Catalog" for tools and supplies suitable to collect and contain fluids on Cat products.

Dispose of all fluids according to local regulations and mandates.

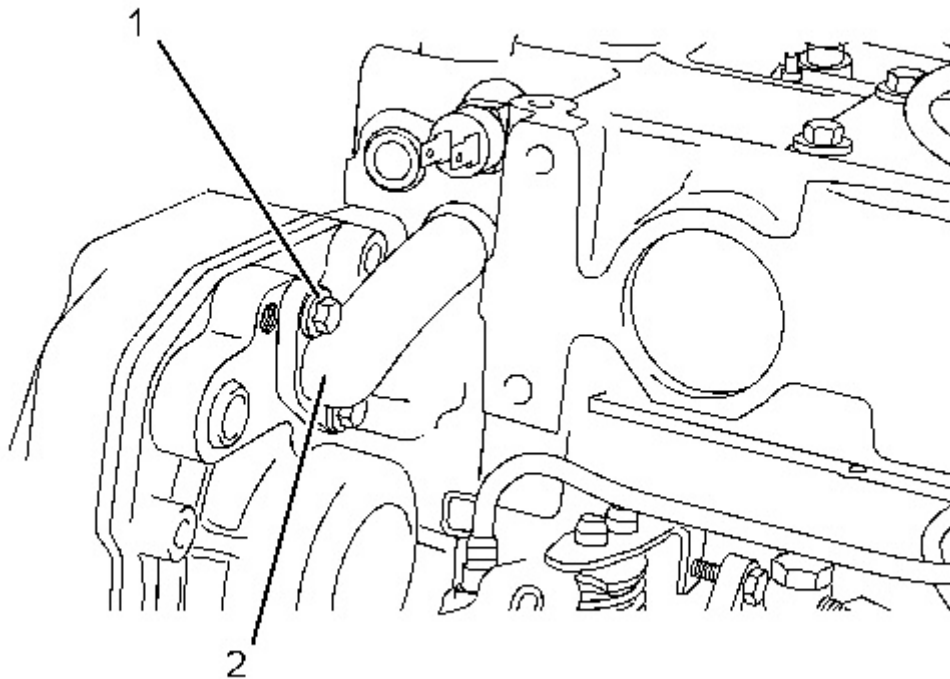

Illustration 1

g03373179

Typical example

1. Remove bolts (1). Remove bypass tube (2) from the cylinder head. Remove the O-ring seals from the bypass tube.
-

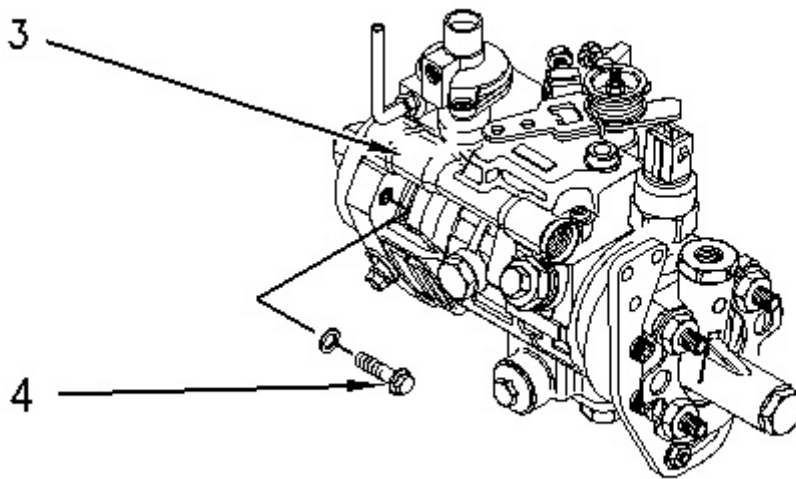

Illustration 2
Typical Example

g00994883

2. Remove bolts (4) that fasten fuel injection pump (3) to the front housing.
-

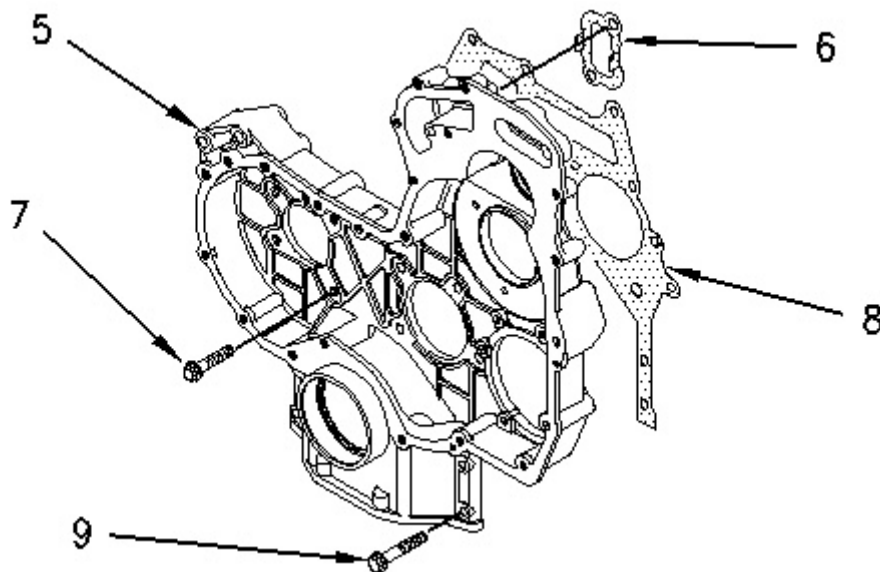

Illustration 3

g00985259

3. Remove bolts (7) and bolts (9) that fasten the front housing (5) to the cylinder block.
 4. Remove front housing (5). Remove gasket (8) from the cylinder block and the front housing.
 5. Remove gasket (6) from the back side of the front housing.
 6. Remove the O-ring seal from the fuel injection pump housing.
-

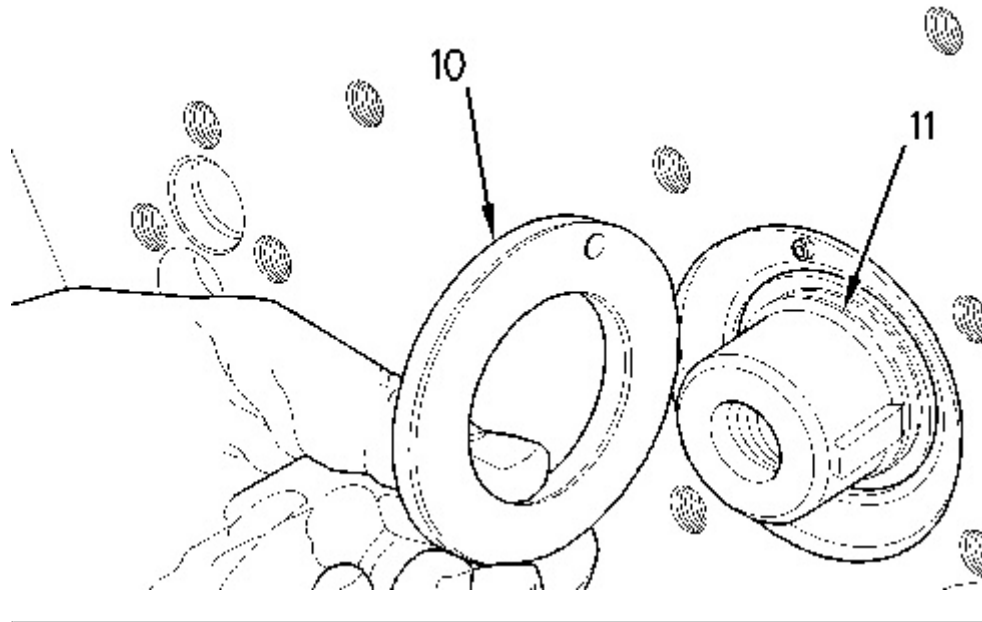

Illustration 4

g00985261

7. Remove thrust washer (10) from camshaft (11).

Product: VIBRATORY COMPACTOR

Model: CB-564D VIBRATORY COMPACTOR C6D

Configuration: CB-564D Vibratory Compactor C6D00001-UP (MACHINE) POWERED BY 3054C Engine

Disassembly and Assembly 3054C Engines for Caterpillar Built Machines

Media Number -SEN5069-18

Publication Date -01/05/2015

Date Updated -19/09/2018

i05324846

Housing (Front) - Install

SMCS - 1151-012

Installation Procedure

Table 1

Tool	Part Number	Part Name	Qty
A	-	Guide Bolt (M8 X 1.25 by 70 mm)	2
B	5P-3975	Rubber Lubricant	-

NOTICE

Keep all parts clean from contaminants.

Contaminants may cause rapid wear and shortened component life.

1. Clean all mating surfaces thoroughly.
-

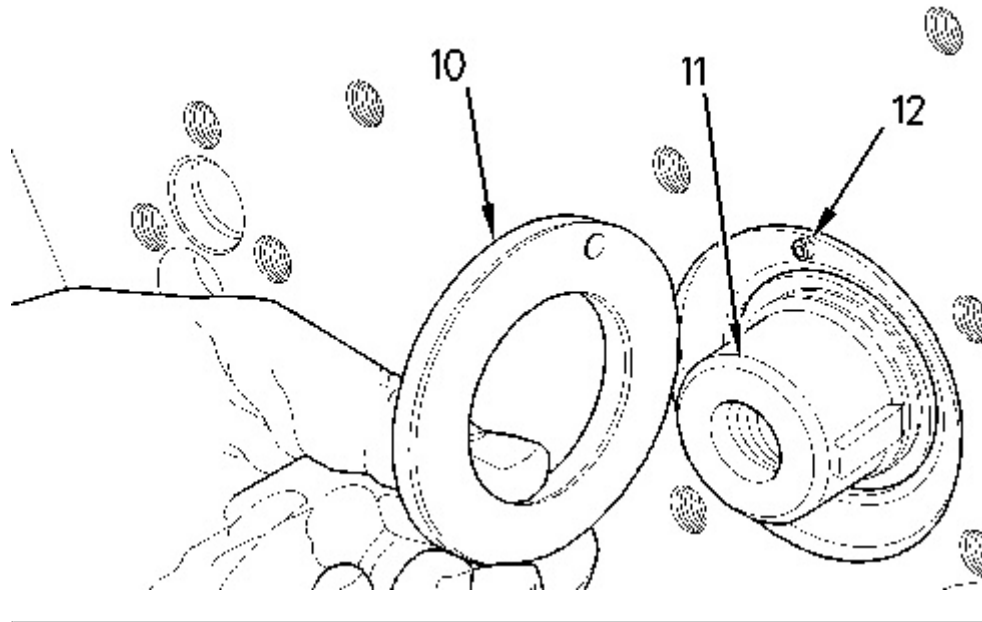

Illustration 1

g00954818

2. Ensure that thrust washer (10) is aligned with hollow dowel (12). Install the thrust washer on camshaft (11).
3. Install a new O-ring seal on the fuel injection pump housing.

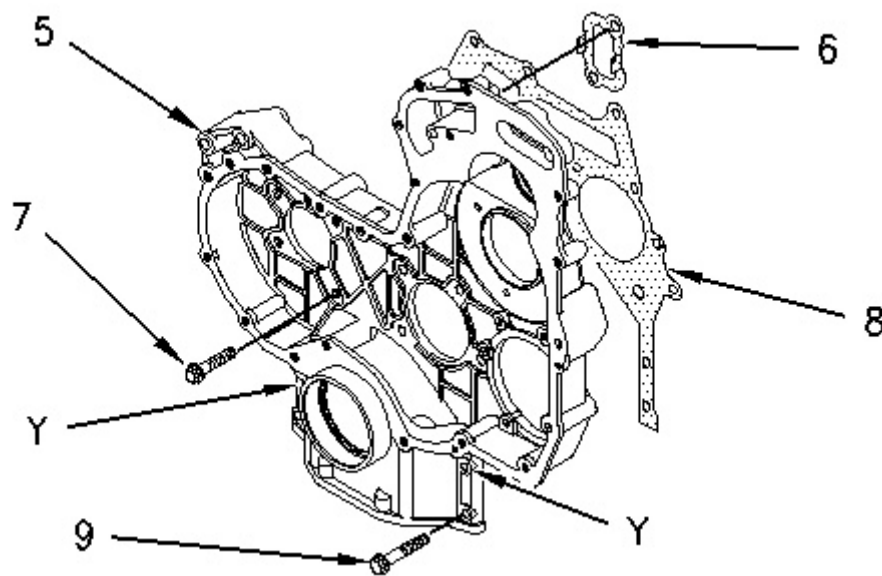

Illustration 2

g00995387

4. Install Tooling (A) in the cylinder block in Hole (Y).
5. Position gasket (8) on Tooling (A). Install gasket (6) on the back side of front housing (5).
6. Position front housing (5) on the cylinder block. Install bolts (7) and bolts (9). Remove Tooling (A) and install the remaining bolts in order to secure the front housing to the cylinder block. Tighten bolts (7) and bolts (9) finger tight at this time.

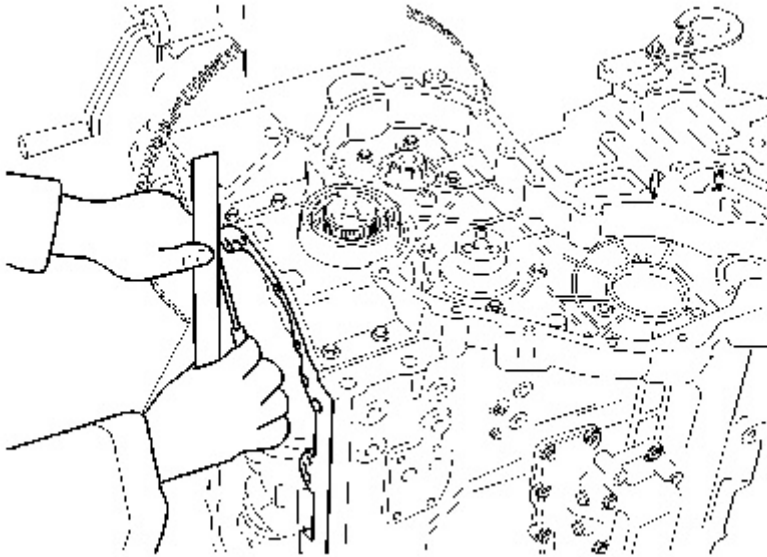

Illustration 3

g00954906

7. Align the front housing and the cylinder block.

Note: Ensure that the bottom of the front cover is aligned with the bottom of the cylinder block before the bolts are tightened. The alignment of the bottom face of the front cover and the bottom of the cylinder block must not exceed 0.00 ± 0.05 mm (0.000 ± 0.002 inch).

8. Tighten bolts (7) and bolts (9) to a torque of 22 N·m (16 lb ft).
-

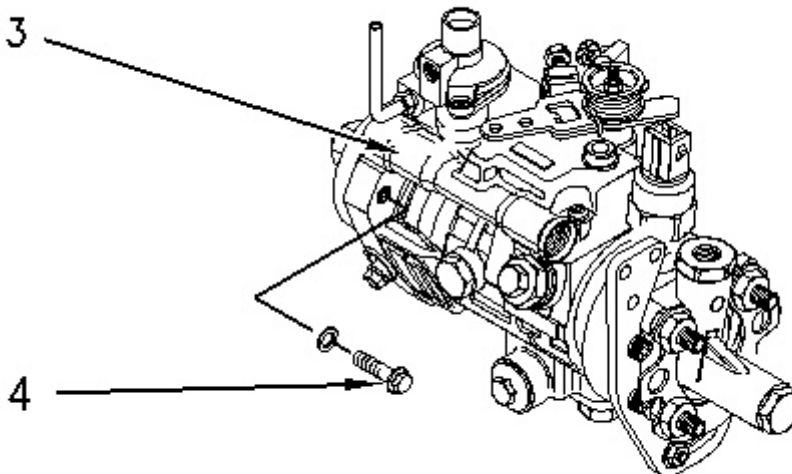

Illustration 4

g00994883

Typical Example

9. Install bolts (4) that fasten fuel injection pump (3) to the front housing. Tighten the bolts to a torque of 25 N·m (18 lb ft).
-

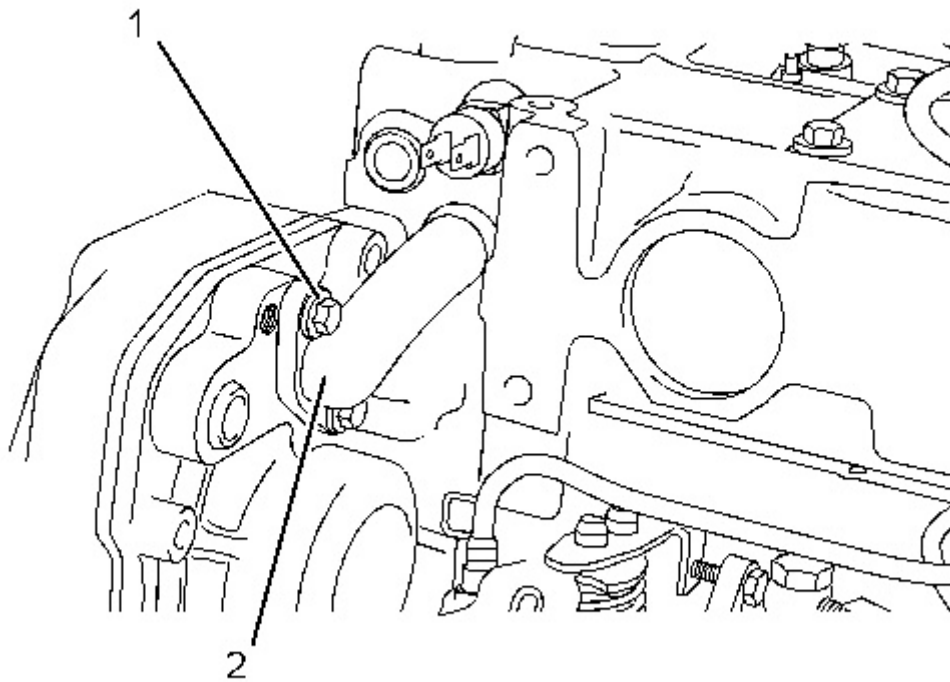

Illustration 5
Typical example

g03373179

10. Install new O-ring seals on bypass tube (2). Apply Tooling (B) to the O-ring seals. Install the bypass tube in the cylinder head. Install bolts (1).

End By:

- a. Install the camshaft gear. Refer to Disassembly and Assembly, "Camshaft Gear - Remove and Install".
- b. Install the idler gear. Refer to Disassembly and Assembly, "Idler Gear - Remove and Install".
- c. Install the engine oil pan. Refer to Disassembly and Assembly, "Engine Oil Pan - Remove and Install".
- d. Install the front cover. Refer to Disassembly and Assembly, "Front Cover - Remove and Install".
- e. Install the crankshaft pulley. Refer to Disassembly and Assembly, "Crankshaft Pulley - Remove and Install".
- f. Install the alternator. Refer to Disassembly and Assembly, "Alternator - Install".
- g. Install the air compressor, if equipped. Refer to Disassembly and Assembly, "Air Compressor - Remove and Install".

Product: VIBRATORY COMPACTOR

Model: CB-564D VIBRATORY COMPACTOR C6D

Configuration: CB-564D Vibratory Compactor C6D00001-UP (MACHINE) POWERED BY 3054C Engine

Disassembly and Assembly 3054C Engines for Caterpillar Built Machines

Media Number -SEN5069-18

Publication Date -01/05/2015

Date Updated -19/09/2018

i02295086

Accessory Drive - Remove and Install

SMCS - 1207-010

Removal Procedure

Table 1

Required Tools			
Tool	Part Number	Part Description	Qty
A	8H-0663	Bearing Puller Gp	1
	5F-7345	Screw	1
	126-7183	Crossblock	1
	126-7181	Sliding Plate	1
	126-7177	Puller Leg	2

NOTICE

Keep all parts clean from contaminants.

Contaminants may cause rapid wear and shortened component life.

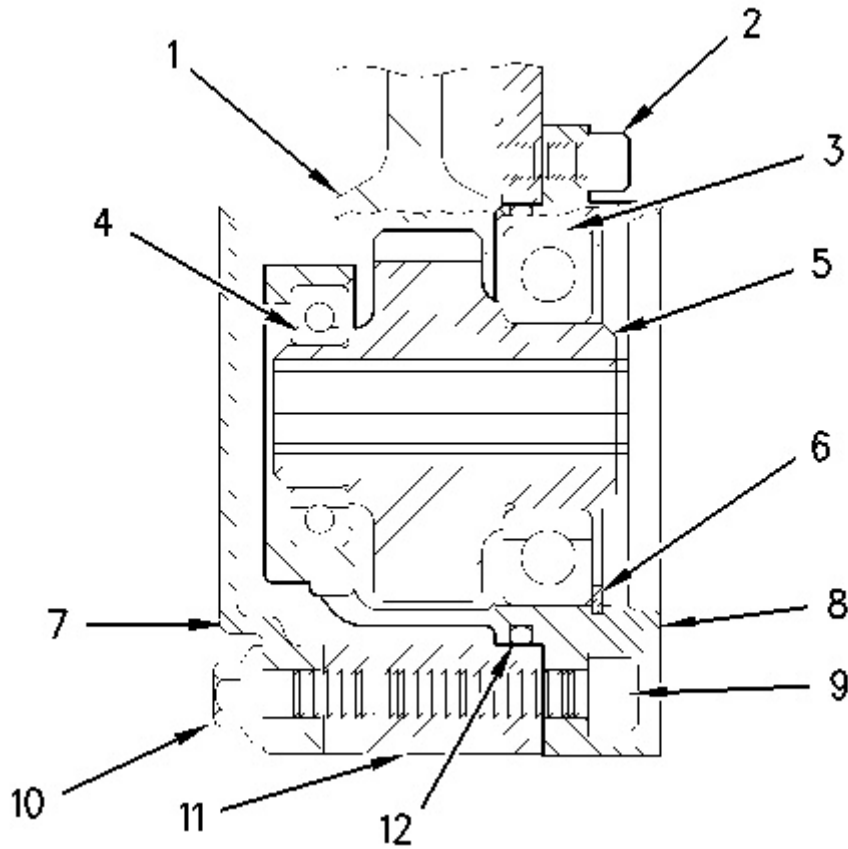

Illustration 1

g00948832

1. Remove the front cover (7). Refer to this Disassembly and Assembly Manual, "Front Cover - Remove and Install".
2. Remove the Allen head screws (2) and (9). Remove the accessory drive assembly (8) from the rear face of the front housing (11).
3. Remove circlip (6) from housing (8).
4. Use the Tooling (A) in order to remove the bearings (3) and (4) from the gear and the housing.
5. Remove the O-ring (12) from the front housing (8) and discard the O-ring.

Installation Procedure

Table 2

Required Tools			
Tool	Part Number	Part Description	Qty
B	7M-7456	Bearing Mount Compound	1

NOTICE

Keep all parts clean from contaminants.

Contaminants may cause rapid wear and shortened component life.

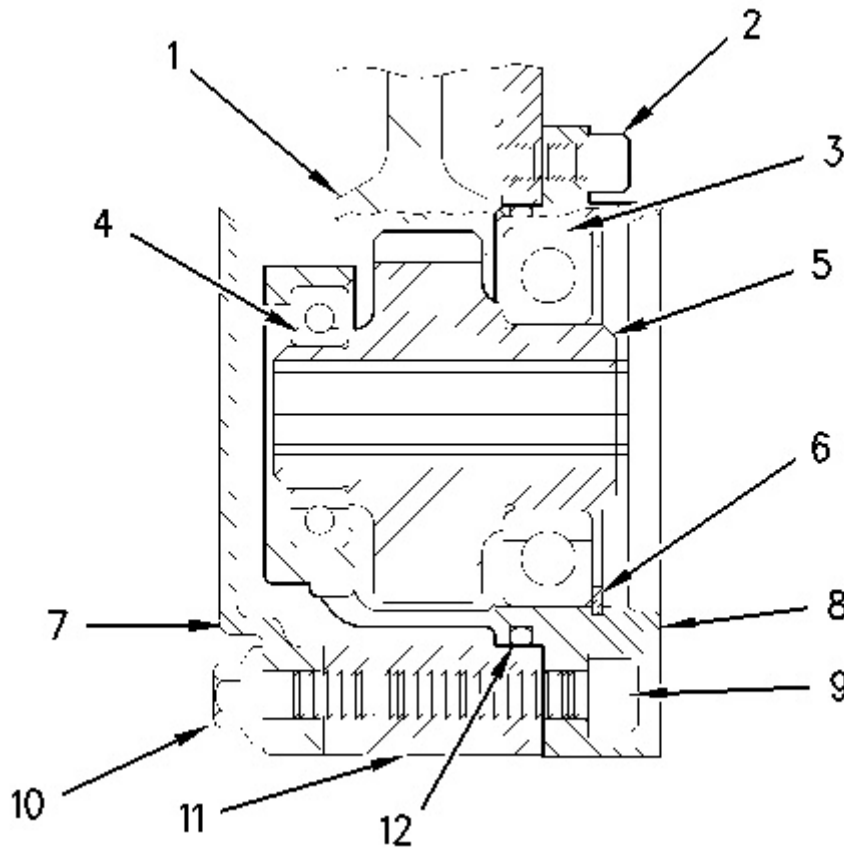

Illustration 2

g00948832

1. Inspect the condition of the teeth and the splines of the gear (5), the bearings (3 and 4), the circlip (6), and the groove for the circlip in the front housing (8) for wear and for damage. Replace any worn component or any damaged component.
2. Apply a small continuous bead of the Tooling (B) to the outer surface of the bearing (4). Support the front face of the housing (8). Position the bearing in the housing. Use a suitable adapter on the outer race of the bearing and press the bearing into the housing (8) until the bearing is against the front face of the recess. Remove any excess bearing mount compound.
3. Apply a small continuous bead of the Tooling (B) to the inner surface of the bearing (4). Support the bearing (4). Position the small hub of the gear (5) toward the bearing and press the gear (5) into the bearing until the shoulder of the gear is against the bearing. Remove any excess bearing mount compound.
4. Apply a small continuous bead of the Tooling (B) to the inner surface and the outer surface of the bearing (3). Support the bearing (4). Use a suitable adapter on the outer race of the bearing (3) and press the bearing into the housing and onto the shoulder of the gear. Remove any excess bearing mount compound.

5. Install the circlip (6) into the groove in the front housing (8). Install a new O-ring seal (12) on housing (8).
 6. Lubricate the O-ring seal with red rubber grease and install the housing in front housing (11). Install Allen head screws (2) and (9) to secure housing (8) in the front housing.
-

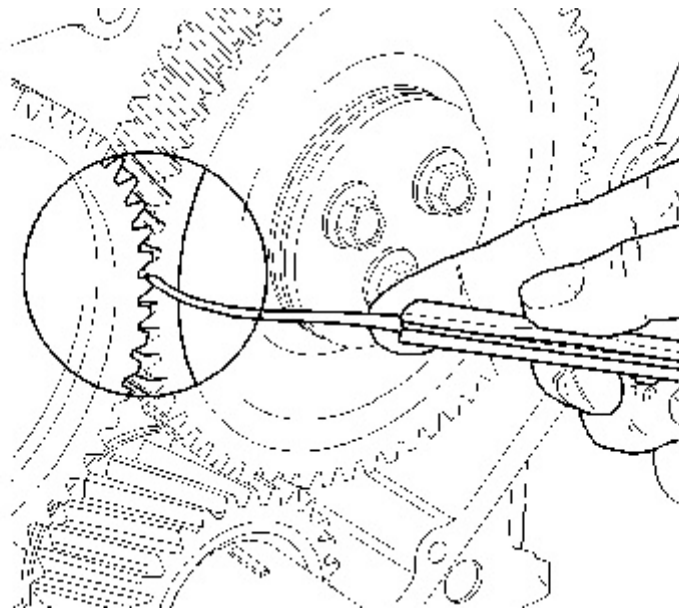

Illustration 3
Typical Example

g00946787

7. Check the backlash between the idler gear and gear (5). The backlash for the gears is 0.11 to 0.17 mm (0.004 to 0.007 inch).
 8. Install the front cover (7) on the front housing. Refer to this Disassembly and Assembly Manual, "Front Cover - Remove and Install".
-

Product: VIBRATORY COMPACTOR

Model: CB-564D VIBRATORY COMPACTOR C6D

Configuration: CB-564D Vibratory Compactor C6D00001-UP (MACHINE) POWERED BY 3054C Engine

Disassembly and Assembly 3054C Engines for Caterpillar Built Machines

Media Number -SEN5069-18

Publication Date -01/05/2015

Date Updated -19/09/2018

i02295089

Crankcase Breather - Remove and Install

SMCS - 1317-010

Removal Procedure

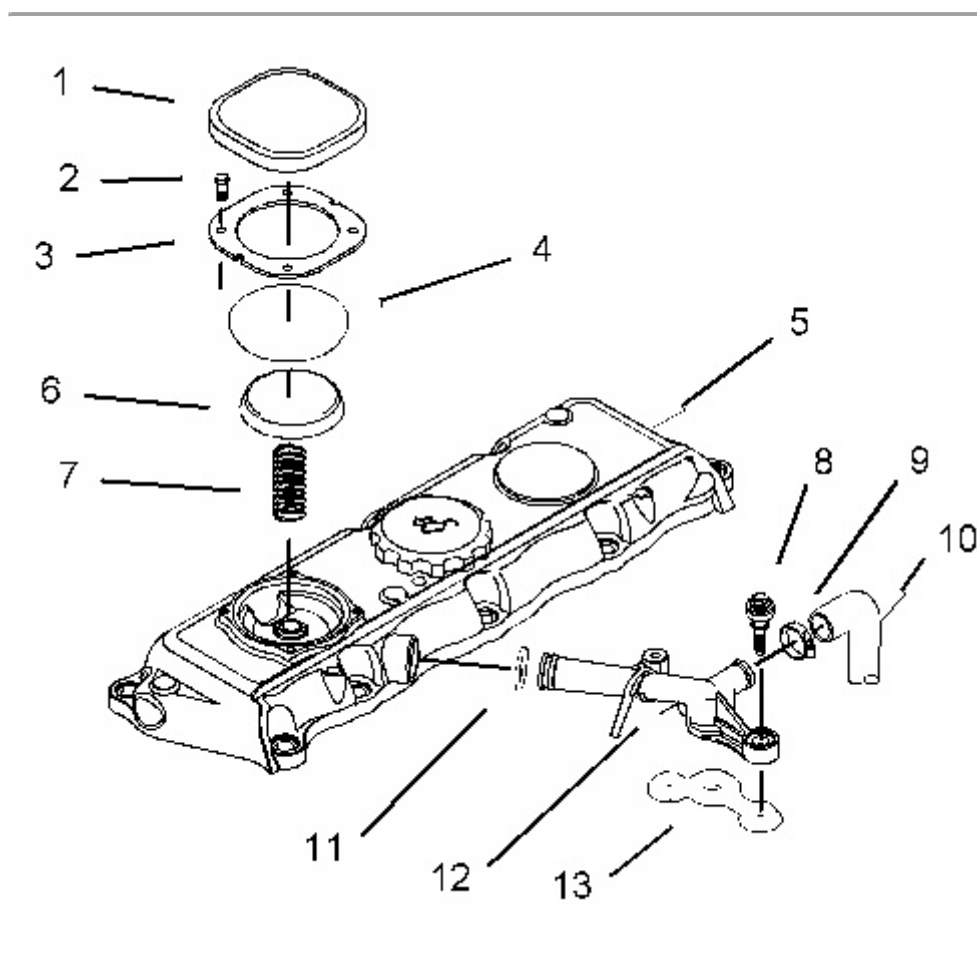

Illustration 1

g01149576

1. Loosen the clamp (9) and remove the hose (10) from the connector (12).
2. Remove the setscrews (8) and remove the connector (12) from the cylinder head. Remove the gasket (13). Remove the O-ring seal (11) from the connector. Discard the gasket (13) and the O-ring seal (11).
3. Remove the cover (1) from the valve mechanism cover (5).

WARNING

Personal injury can result from parts and/or covers under spring pressure.

Spring force will be released when covers are removed.

Be prepared to hold spring loaded covers as the bolts are loosened.

4. Remove the screws (2). Remove the plate (3).
5. Remove the diaphragm (4) and the cap (6). Remove the spring (7).

Installation Procedure

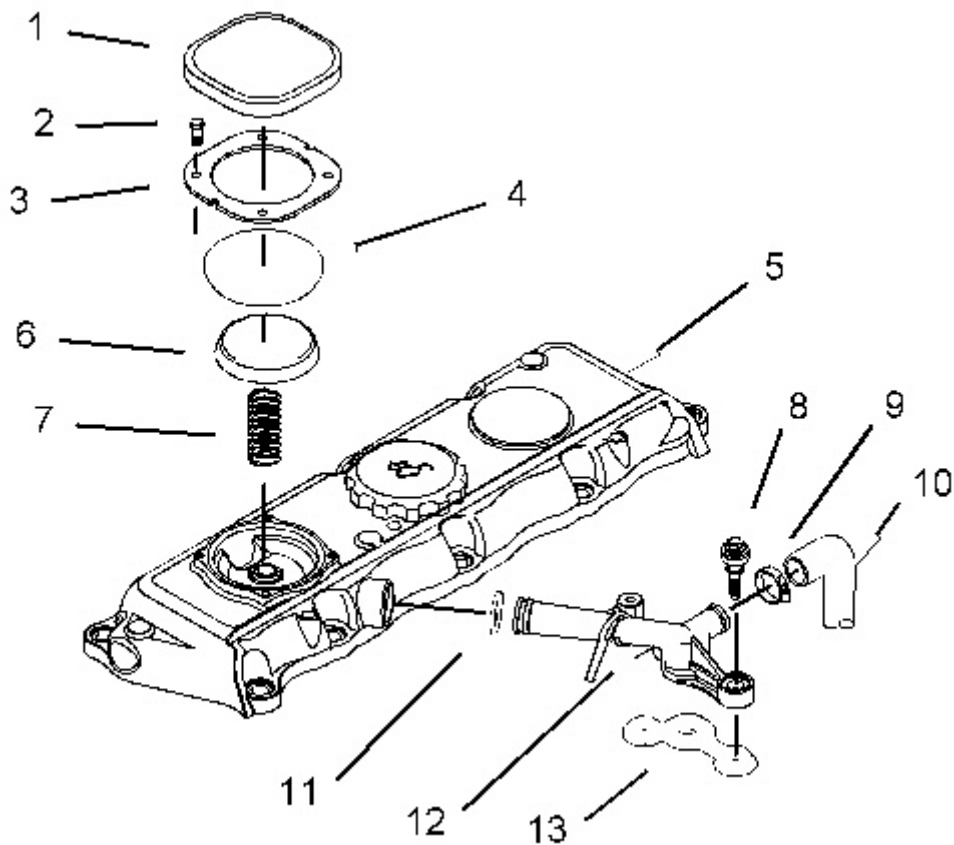



Improper assembly of parts that are spring loaded can cause bodily injury.

To prevent possible injury, follow the established assembly procedure and wear protective equipment.

1. Install the spring (7), the cap (6), and the diaphragm (4).
 2. Install the plate (3). Install the screws (2).
 3. Install the cover (1) on the valve mechanism cover.
 4. Install a new O-ring seal (11) on the connector (12). Install a new gasket (13) on the connector (12). Position the connector in the valve mechanism cover.
 5. Install the setscrews (8). Tighten the setscrews to a torque of 9 N·m (80 lb in).
 6. Install the hose (10) on the connector (12). Tighten the clamp (9) to a torque of 5 N·m (44 lb in).
-

Product: VIBRATORY COMPACTOR

Model: CB-564D VIBRATORY COMPACTOR C6D

Configuration: CB-564D Vibratory Compactor C6D00001-UP (MACHINE) POWERED BY 3054C Engine

Disassembly and Assembly 3054C Engines for Caterpillar Built Machines

Media Number -SEN5069-18

Publication Date -01/05/2015

Date Updated -19/09/2018

i02295100

Valve Mechanism Cover - Remove and Install

SMCS - 1107-010

Removal Procedure

Start By:

- a. Remove the heat shields, if equipped.
- b. Remove the cover for the fuel injection nozzles. Refer to this Disassembly and Assembly Manual, "Fuel Injection Nozzle Cover - Remove and Install".

NOTICE

Keep all parts clean from contaminants.

Contaminants may cause rapid wear and shortened component life.

NOTICE

Care must be taken to ensure that fluids are contained during performance of inspection, maintenance, testing, adjusting, and repair of the product. Be prepared to collect the fluid with suitable containers before opening any compartment or disassembling any component containing fluids.

Refer to Special Publication, NENG2500, "Dealer Service Tool Catalog" for tools and supplies suitable to collect and contain fluids on Cat products.

Dispose of all fluids according to local regulations and mandates.

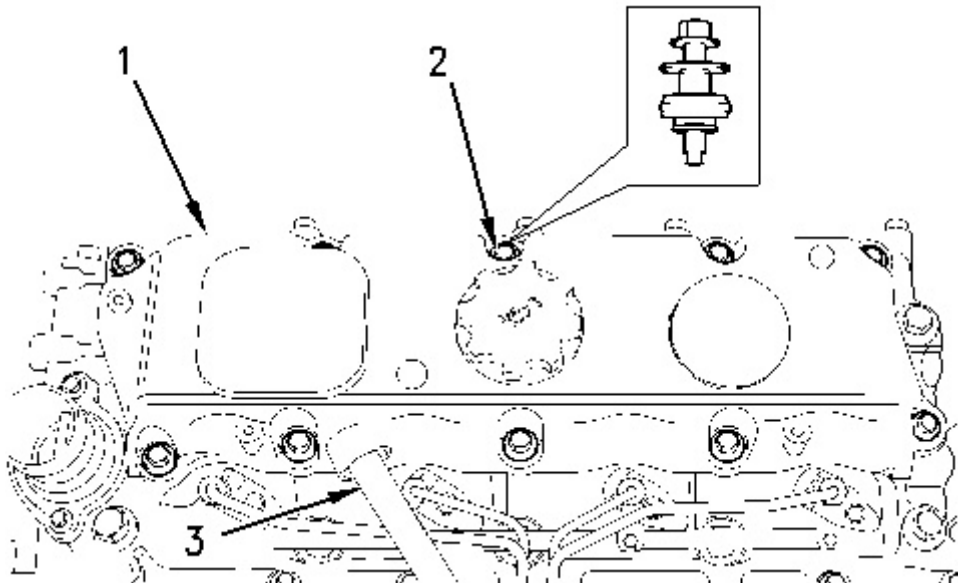
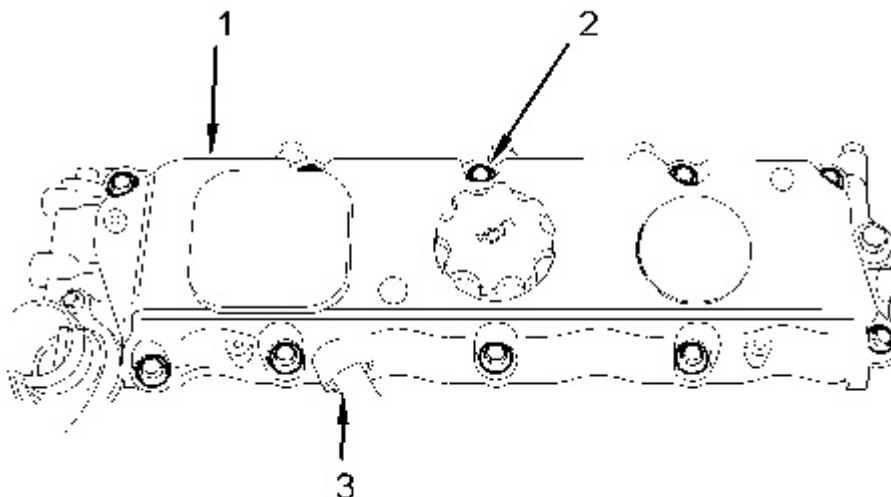

Illustration 1

g00951080

1. Remove the breather tube (3) from the valve mechanism cover (1). Refer to this Disassembly and Assembly Manual, "Crankcase Breather - Remove and Install".
2. Remove the fasteners (2). Remove valve mechanism cover (1). Remove the gasket from the cylinder head and discard the gasket.

Installation Procedure



1. Thoroughly clean the valve mechanism cover (1). Ensure that the groove for the gasket for the valve mechanism cover (1) is clean and dry. Ensure that the mating face on the cylinder head is clean and dry.
 2. If the valve mechanism cover (1) is equipped with an oil filler cap, check the condition of the O-ring for the oil filler cap. If necessary, replace the O-ring.
 3. Check the condition of the fasteners (2). Replace the fasteners (2), if necessary.
 4. Install the gasket and valve mechanism cover (1) on the cylinder head.
-

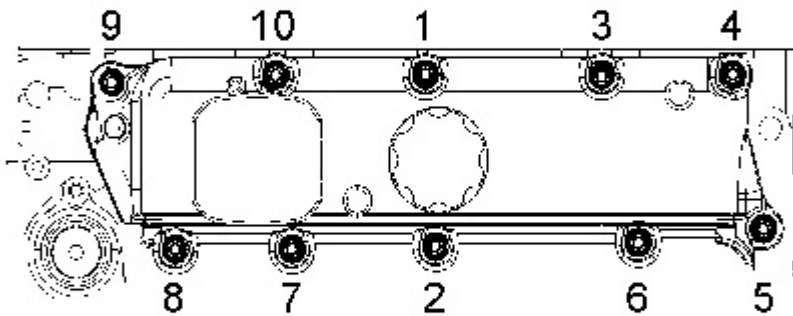

5. Install the fasteners (2). Tighten the fasteners in the sequence that is shown in Illustration 3 to a torque of 9 N·m (80 lb in).
6. Connect breather tube (3) to the valve mechanism cover. Refer to this Disassembly and Assembly Manual, "Crankcase Breather - Remove and Install".

End By:

- a. Install the cover for the fuel injection nozzles. Refer to this Disassembly and Assembly Manual, "Fuel Injection Nozzle Cover - Remove and Install".

Thank you so much for reading.
Please click the “Buy Now!”
button below to download the
complete manual.



After you pay.

You can download the most
perfect and complete manual in
the world immediately.

Our support email:

ebooklibonline@outlook.com