

Product: COMPACTOR

Model: CB16 COMPACTOR KHC

Configuration: CB16 Asphalt Compactor KHC00001-UP (MACHINE) POWERED BY C4.4B Engine

Disassembly and Assembly CB13, CB15, and CB16 Asphalt Compactors Machine Systems

Media Number -M0091213-00

Publication Date -01/04/2018

Date Updated -24/04/2018

i07332874

Final Drive Planetary - Assemble

SMCS - 4050-016; 4084-016

Assembly Procedure

Table 1

Required Tools			
Tool	Part Number	Part Description	Qty
A	150-1782	Crossblock	1
	1U-5230	Hydraulic Pump Assembly	1
	126-7179	Puller Leg	2
	4C-4660	Adapter-Threaded	2
	3H-0465	Push-Puller Plate	4
	360-6956	Hydraulic Cylinder	1
C	1P-2420	Transmission Repair Stand	1
F	6V-6080	Torque Multiplier Gp	1
	524-2773	Socket As	1
H	439-3939	Link Bracket As	3
K	1U-6438	Duo-Cone Seal Installer As	1
L	-	Loctite 243	-
M	4C-3760	C-Clamp	2
N	159-9074	Installer As	1



Illustration 1

g06173098

1. Install roller bearing (45) and retaining ring (44) onto shaft assembly (43).



Illustration 2

g06173089

2. Use a soft faced hammer to install shaft assembly (43) into spindle (41).
3. Install retaining ring (42) into spindle (41).



Illustration 3

g06176752



Illustration 4

g06173085

4. Use Tooling (K) to install duo-cone seal (40) onto spindle (41). Refer to Disassembly and Assembly, Duo-Cone Conventional Seals - Install in this manual.



Illustration 5

g06176820

5. Raise the temperature of bearing cone (39) and spacer (38). Install bearing cone (39) and spacer (38) onto spindle (41).



Illustration 6

g06172906

6. Lower the temperature of bearing cups (37). Install bearing cups (37) into hub (34).

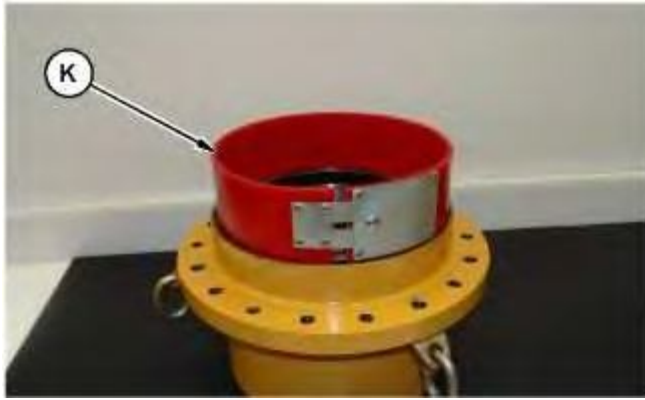

Illustration 7

g06175464



Illustration 8

g06172779

7. Use Tooling (K) to install duo-cone seal (36) into hub (34). Refer to Disassembly and Assembly, Duo-Cone Conventional Seals - Install in this manual.



Illustration 9

g06172778

8. Use Tooling (H) and a suitable lifting device to install hub (34). The weight of hub (34) is approximately 37 kg (80 lb).



Illustration 10

g06176829

9. Use Tooling (M) to compress hub (34).



Illustration 11

g06176839

10. Raise the temperature of bearing cone (35). Install bearing cone (35) into hub (34).



Illustration 12

g06172775

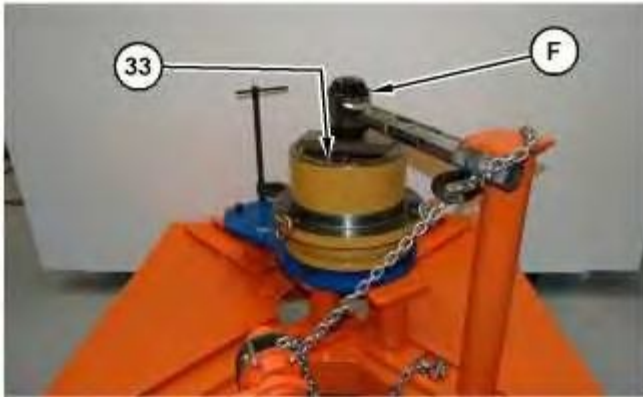

Illustration 13

g06176844

! WARNING

Improper assembly of parts that are spring loaded can cause bodily injury.

To prevent possible injury, follow the established assembly procedure and wear protective equipment.

11. Apply Tooling (L) to bearing locknut (33). Install bearing locknut (33).
12. Use Tooling (F) to tighten bearing locknut (33) to a torque of 2000 N·m (1475 lb ft).



Illustration 14

g06175460

13. Use Tooling (N) to install gears (32). Install retaining rings (31).



Illustration 15

g06175461

14. Install gear (30) and gear (29).



Illustration 16

g06175463

15. Install spacer (26), gears (28), and retaining rings (27) onto carrier assembly (25).



Illustration 17

g06172762

16. Install carrier assembly (25).



Illustration 18

g06175465



Illustration 19

g06172761

17. Install gear (23) and retaining ring (24) onto carrier assembly (18).



Illustration 20

g06175466

18. Install gears (22) and retaining rings (21) onto the carrier assembly.

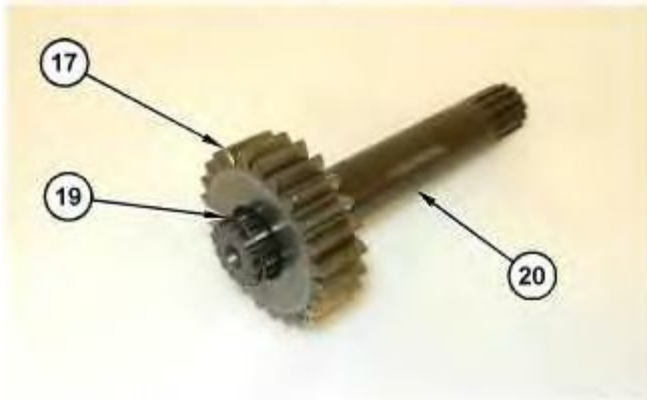

Illustration 21

g06172755

19. Install gear (17) and retaining ring (19) onto shaft (20).



Illustration 22

g06172753

20. Install carrier assembly (18) and gear (17).



Illustration 23

g06172748

21. Install O-ring seal (16) onto gear (15).

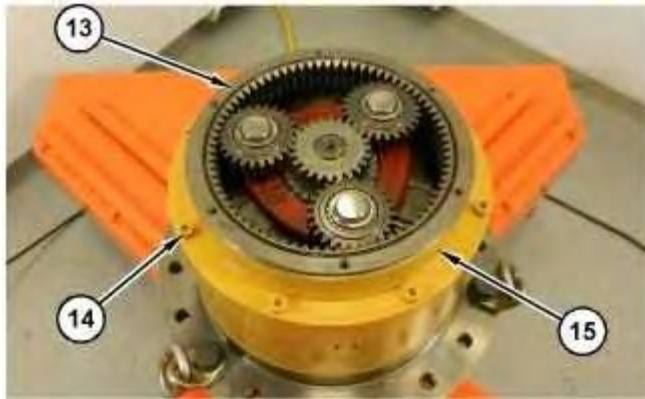

Illustration 24

g06172743

22. Install gear (15), bolts (14), and O-ring seal (13).

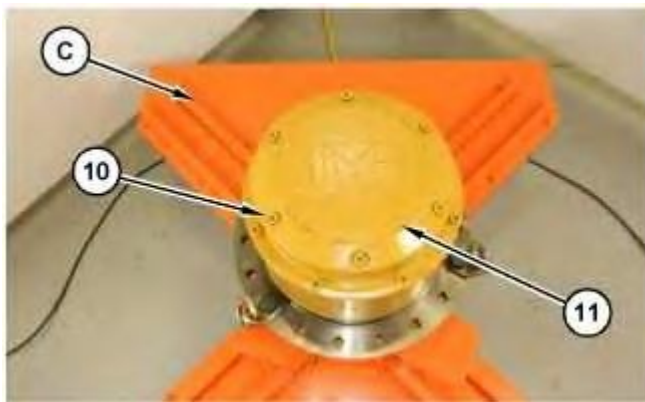

Illustration 25

g06172653

23. Install cover (11) and bolts (10).
24. Remove the final drive from Tooling (C) or a suitable bench. The weight of the final drive is approximately 110 kg (243 lb).



Illustration 26

g06172742

25. Install backup rings (8) and O-ring seals (9).



Illustration 27

g06172740

26. Install discs (7) and the shims.

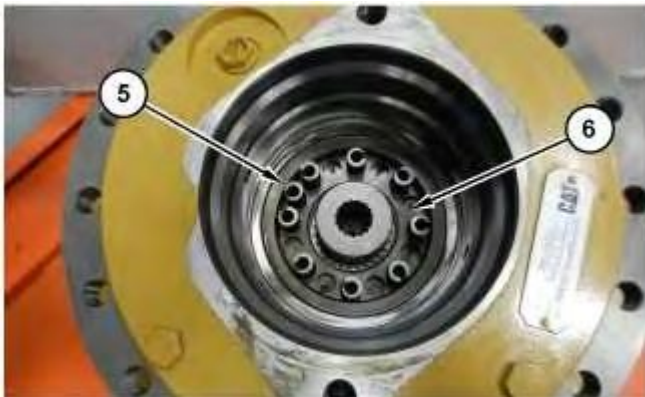

Illustration 28

g06175467

27. Install piston (6) and springs (5).

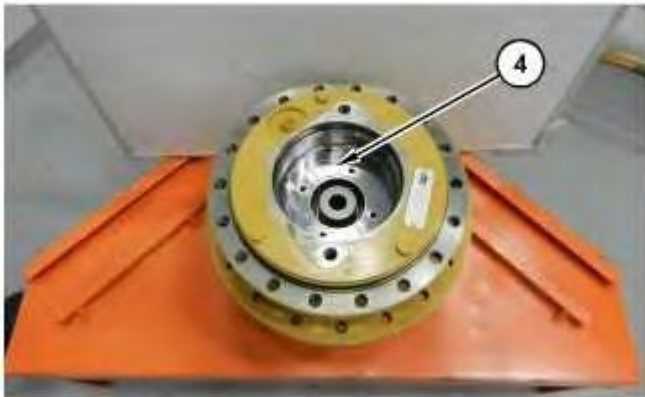

Illustration 29

g06172716

28. Install plate (4).

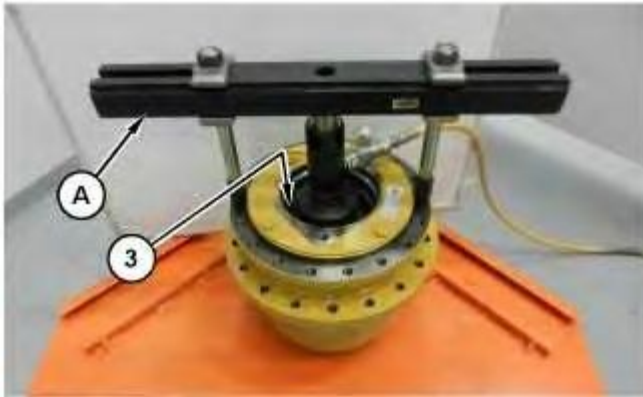

Illustration 30

g06172710

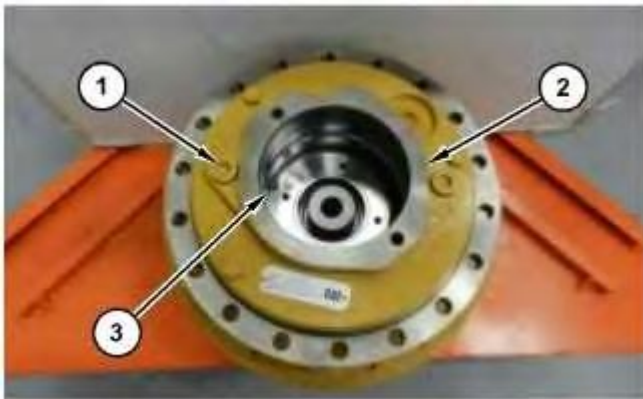

Illustration 31

g06172670

WARNING

Improper assembly of parts that are spring loaded can cause bodily injury.

To prevent possible injury, follow the established assembly procedure and wear protective equipment.

29. Use Tooling (A) to compress the plate to retaining ring (3).
30. Install retaining ring (3).
31. Release pressure from Tooling (A). Remove Tooling (A).
32. Install flange (2), the O-ring seal, and bolts (1).

End By:

- a. Refill the final drive planetary. Refer to Operation and Maintenance Manual, KEBU7590 for "Lubricant Viscosities" and "Capacities (Refill)".

- b. Install the final drive planetary. Refer to Disassembly and Assembly, Final Drive Planetary-Remove and Install in this manual.
-

Product: COMPACTOR

Model: CB16 COMPACTOR KHC

Configuration: CB16 Asphalt Compactor KHC00001-UP (MACHINE) POWERED BY C4.4B Engine

Disassembly and Assembly CB13, CB15, and CB16 Asphalt Compactors Machine Systems

Media Number -M0091213-00

Publication Date -01/04/2018

Date Updated -24/04/2018

i07352986

Articulating Hitch - Remove and Install

SMCS - 7057-010

Removal Procedure

Table 1

Required Tools			
Tool	Part Number	Part Description	Qty
A	417-1324	Adjustable Stand As	1
B	1U-9202	Lever Puller Hoist Gp	1
C	444-0526	Manual/Hydraulic Jack Gp	1

Start By:

- a. Remove the support (cab).
 - b. Remove the water tank.
 - c. Remove the hydraulic cylinder (steering).
 - d. Remove the water spray pump.
1. Release the system pressure.
 2. Drain the hydraulic oil. Refer to Operation and Maintenance Manual, "Hydraulic System Oil - Change" for the correct draining procedure.
-



Illustration 1

g02902137

3. Raise the machine and install Tooling (A) under both sides of the machine.



Illustration 2

g06246868

4. Attach a suitable lifting device to rear frame (1).

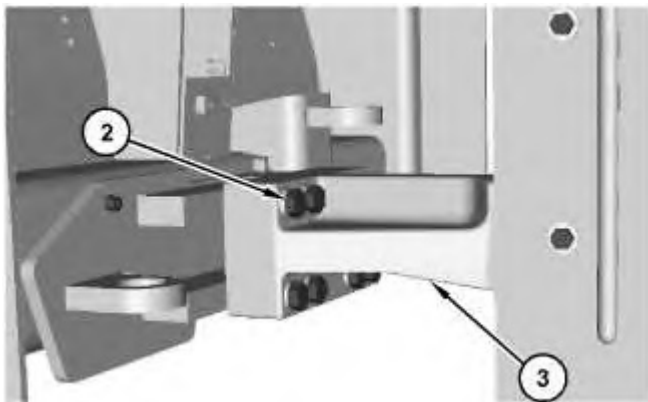

Illustration 3

g06246876



Illustration 4

g06246868

5. Remove bolts (2).
6. Lift rear frame (1) and position rear frame (1) to provide clearance for articulating hitch (3).
7. Position rear frame (1) on suitable cribbing.

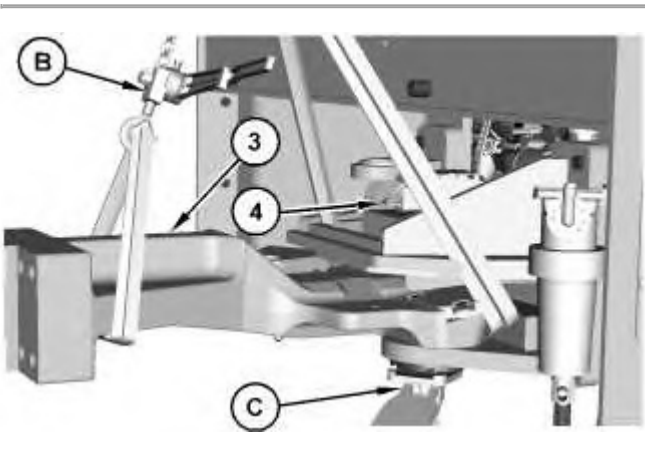

Illustration 5

g06246899

Note: Illustration 5 is for reference only.

8. Disconnect harness assembly (4).
9. Attach a suitable lifting device, Tooling (B), and Tooling (C) to remove articulating hitch (3). The weight of articulating hitch (3) is approximately 340 kg (750 lb).
10. Position suitable cribbing in articulating hitch (3) to prevent the rotation of articulating hitch (3).
11. Position suitable cribbing in articulating hitch (3) to prevent the buckling of articulating hitch (3) which would damage the seals.

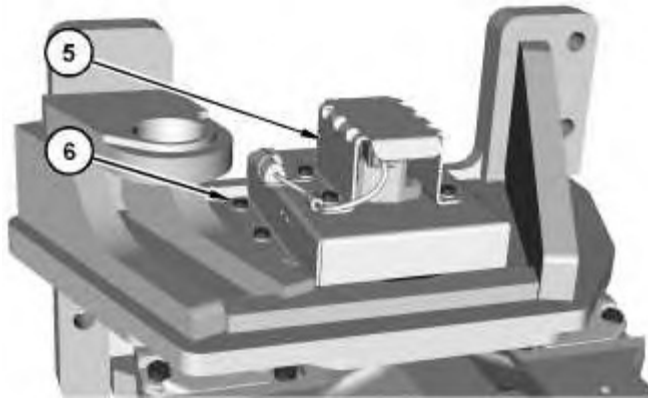

Illustration 6 g06246905

The machine has been removed for image clarity.

12. Remove bolts (6) and sensor assembly (5).

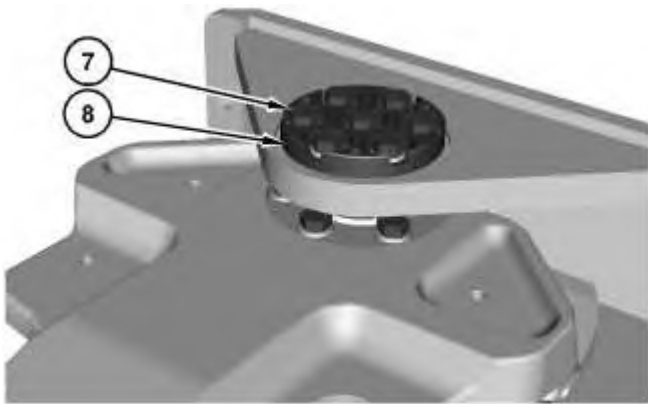

Illustration 7 g06246911

The machine has been removed for image clarity.

13. Remove bolts (7).

14. Remove pin (8) using the pusher holes.

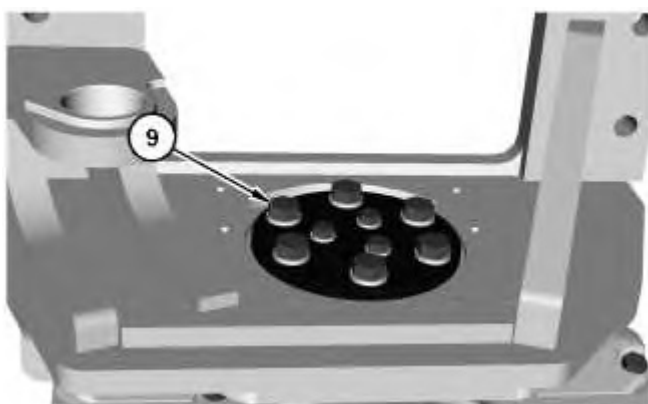

Illustration 8 g06246914

The machine has been removed for image clarity.

15. Remove bolts (9).

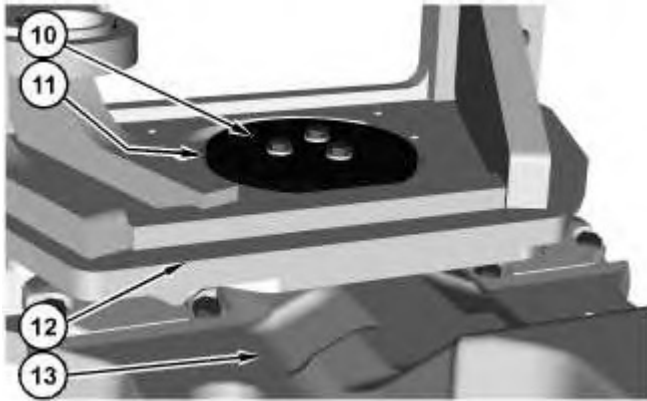

Illustration 9

g06246923

The machine has been removed for image clarity.

16. Remove pin assembly (10) and shims (11) (not shown).

17. Separate mount (12) from hitch (13).

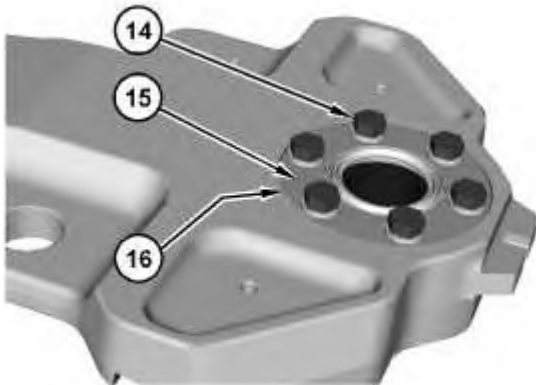

Illustration 10

g06246927

18. Remove bolts (14), plate (15), and shims (16) (not shown).

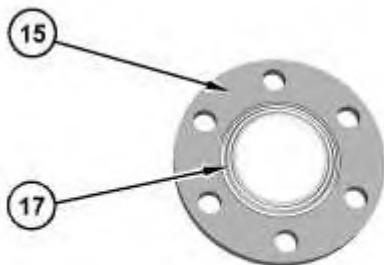

Illustration 11

g06246930

19. Remove lip seal (17) from plate (15).

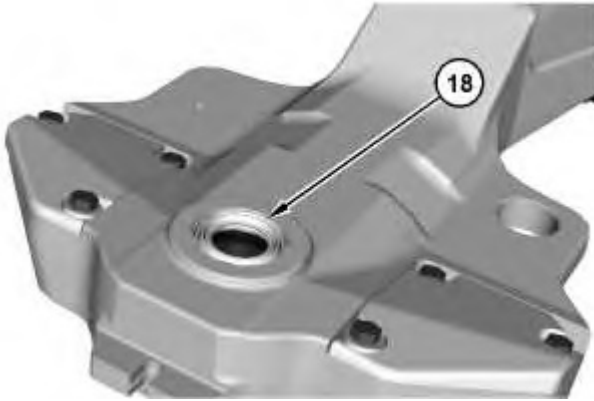

Illustration 12

g06246933

20. Remove lip seal (18).



Illustration 13

g06246942



Illustration 14

g06246946

21. Remove bearing (19) and bearing (20).

Installation Procedure

Thank you so much for reading.
Please click the “Buy Now!”
button below to download the
complete manual.



After you pay.

You can download the most
perfect and complete manual in
the world immediately.

Our support email:

ebooklibonline@outlook.com