

Product: COMPACTOR

Model: CB-34B XW COMPACTOR 425

Configuration: CB34B XW Compactor 42500001-UP (MACHINE) POWERED BY C2.2 Engine

Disassembly and Assembly

C1.5 and C2.2 Engines for Caterpillar Built Machines

Media Number -UENR3332-01

Publication Date -01/09/2013

Date Updated -07/06/2016

i05298395

Camshaft - Remove - Camshaft for C1.5 and C2.2 Engines

SMCS - 1210-011

Removal Procedure

Start By:

- a. Remove the lifters. Refer to Disassembly and Assembly, "Lifter Group - Remove and Install" for the correct procedure.
- b. Remove the front housing. Refer to Disassembly and Assembly, "Housing (Front) - Remove" for the correct procedure.

NOTICE

Keep all parts clean from contaminants.

Contaminants may cause rapid wear and shortened component life.

NOTICE

Care must be taken to ensure that fluids are contained during performance of inspection, maintenance, testing, adjusting and repair of the product. Be prepared to collect the fluid with suitable containers before opening any compartment or disassembling any component containing fluids.

Dispose of all fluids according to local regulations and mandates.

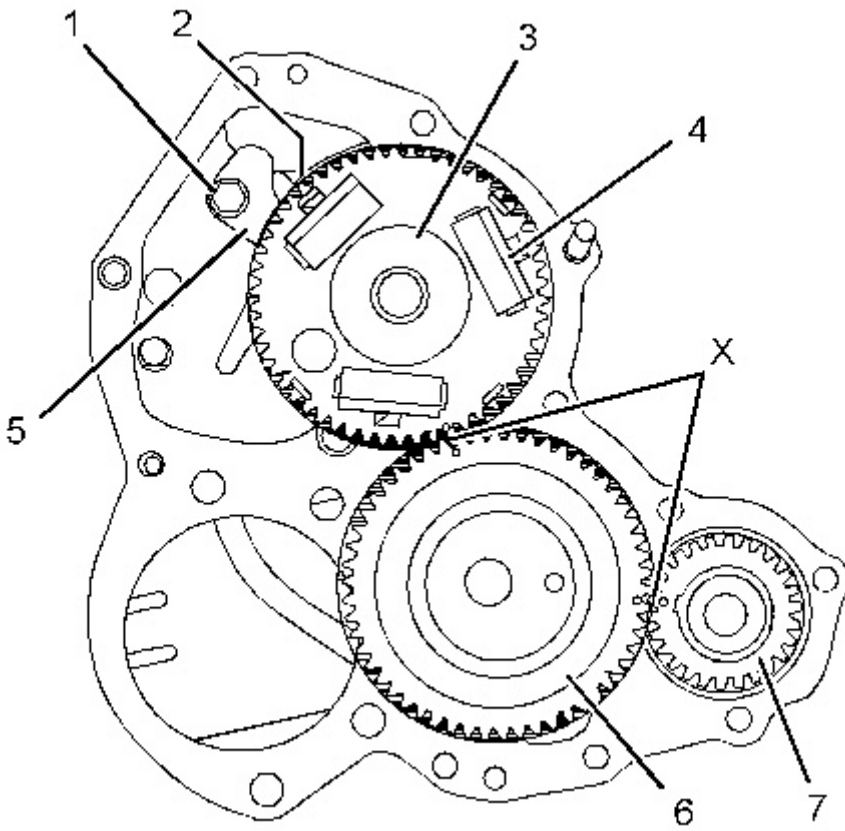

Illustration 1

g03337464

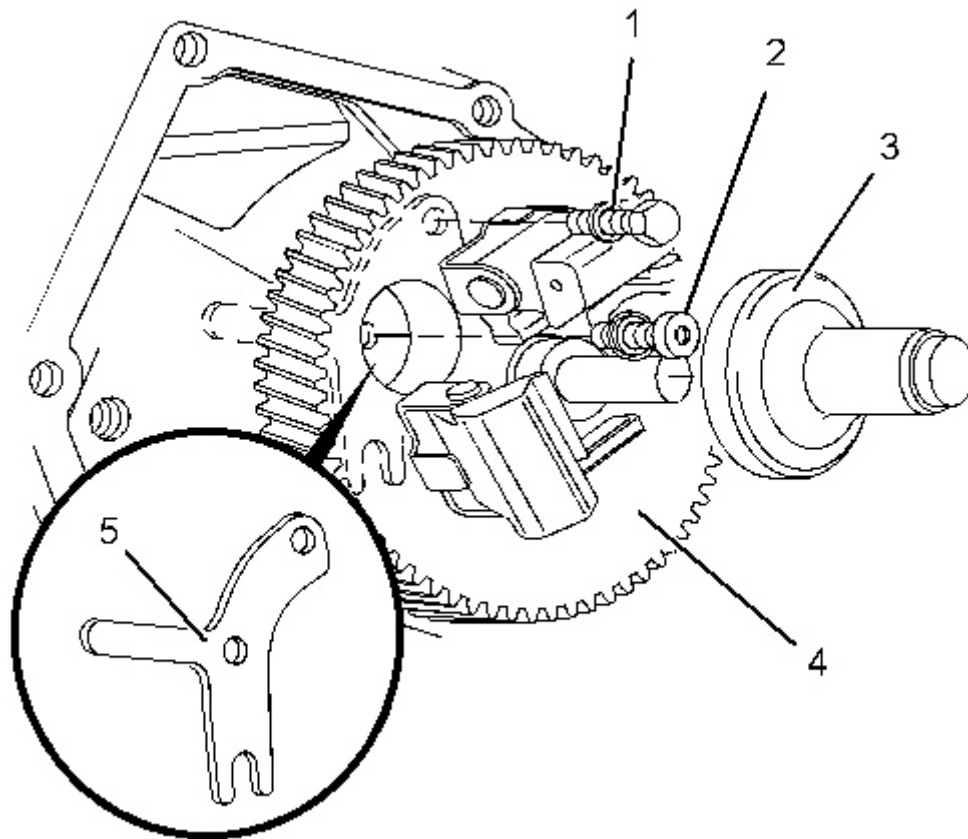

Illustration 2

g03337466

1. Remove slider (3) from camshaft gear (4).

Note: For C1.5 engines have a different camshaft retainer and different fasteners to C2.2 engines. The removal procedure is similar for all models.

2. Rotate camshaft gear (4) in order to align the access hole in the camshaft gear with allen head screw (2) and bolt (1). Remove allen head bolt (2) and bolt (1).

Note: For C1.5 engines, have allen head bolt (2) and bolt (1) installed.

3. Rotate camshaft gear (4) in order to align the access hole in the camshaft gear with bolts (1). Remove bolts (1).

Note: For C2.2 engines, have bolts (1) installed.

4. Remove camshaft retainer (5).

5. Rotate the crankshaft until timing Marks (X) are aligned with crankshaft gear (7), camshaft gear (4), and idler gear (6)
-

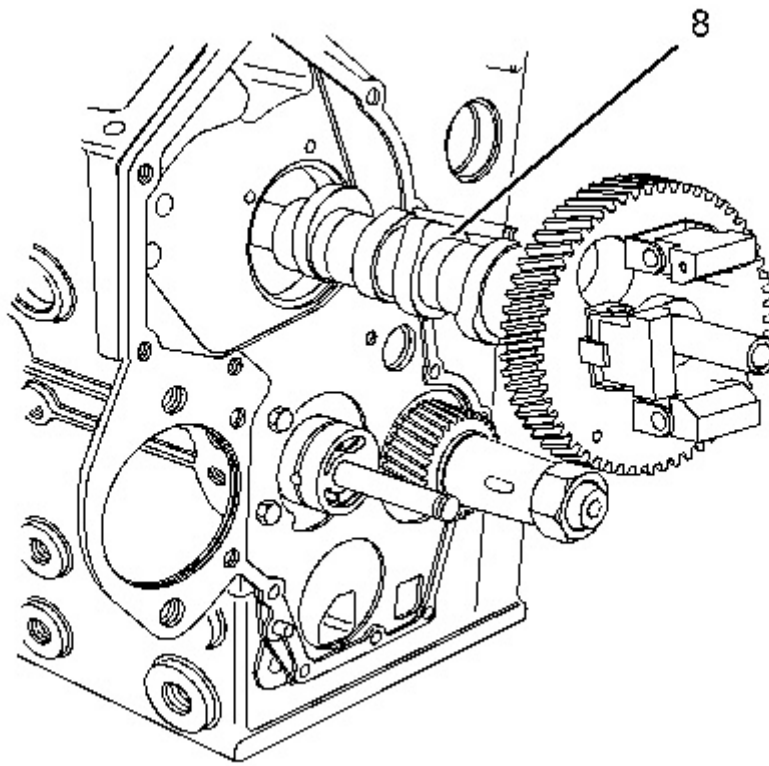

Illustration 3

g03337467

6. Carefully remove camshaft assembly (8) from the cylinder block.

Note: Ensure that the lobes of the camshaft and the camshaft bearings are not damaged.

Product: COMPACTOR

Model: CB-34B XW COMPACTOR 425

Configuration: CB34B XW Compactor 42500001-UP (MACHINE) POWERED BY C2.2 Engine

Disassembly and Assembly C1.5 and C2.2 Engines for Caterpillar Built Machines

Media Number -UENR3332-01

Publication Date -01/09/2013

Date Updated -07/06/2016

i05298393

Camshaft - Disassemble

SMCS - 1210-015

Disassembly Procedure

Table 1

Required Tools			
Tool	Part Number	Part Description	Qty
A	-	Combination Puller	1

Start By:

- a. Remove the camshaft assembly. Refer to Disassembly and Assembly, "Camshaft - Remove" for the correct procedure.

NOTICE

Keep all parts clean from contaminants.

Contaminants may cause rapid wear and shortened component life.

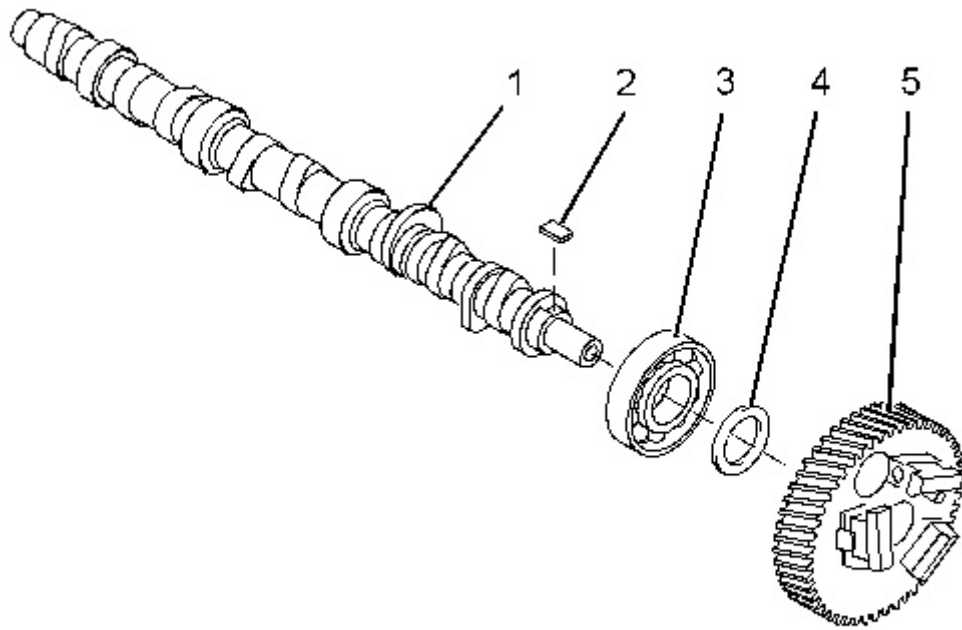

Illustration 1

g03337902

1. Use Tooling (A) in order to remove gear (5) from camshaft (1).

Note: The gear should be positioned on a suitable support in order to prevent damage to the governor flyweights during disassembly.

2. Remove spacer (4) and woodruff key (2) from camshaft (1).
3. Use Tooling (A) to remove bearing (3) from camshaft (1).

Note: Identify the orientation of the bearing for installation purposes.

Product: COMPACTOR

Model: CB-34B XW COMPACTOR 425

Configuration: CB34B XW Compactor 42500001-UP (MACHINE) POWERED BY C2.2 Engine

Disassembly and Assembly C1.5 and C2.2 Engines for Caterpillar Built Machines

Media Number -UENR3332-01

Publication Date -01/09/2013

Date Updated -07/06/2016

i05298392

Camshaft - Assemble

SMCS - 1210-016

Assembly Procedure

NOTICE

Keep all parts clean from contaminants.

Contaminants may cause rapid wear and shortened component life.

1. Ensure that all components of the camshaft assembly are clean and free from damage. Replace any components that are worn or damaged.
-

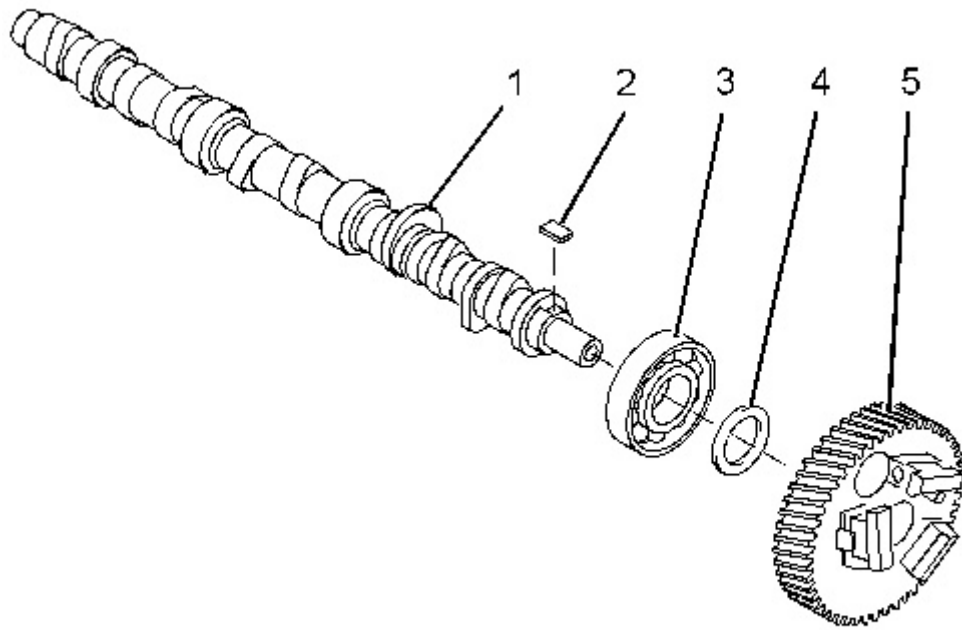

Illustration 1

g03337902

2. Lubricate the nose of camshaft (1) with clean engine oil. Use a suitable press to install bearing (3) to the camshaft.

Note: Ensure that the bearing is installed in the correct orientation. The camshaft bearing should be pressed squarely onto the camshaft or damage to the bearing may occur. Do not press on the outer race of the bearing.

3. Install spacer (4) and woodruff key (2) to camshaft (1). Ensure that the woodruff key is correctly seated into the recess of the camshaft.
4. Align gear (5) with woodruff key (2). Use a suitable press to install the gear to the nose of camshaft (1).

Note: The gear should be positioned on a suitable support in order to prevent damage to the governor flyweights during installation.

End By:

- a. Install the camshaft assembly. Refer to Disassembly and Assembly, "Camshaft - Install" for the correct procedure.
-

Product: COMPACTOR

Model: CB-34B XW COMPACTOR 425

Configuration: CB34B XW Compactor 42500001-UP (MACHINE) POWERED BY C2.2 Engine

Disassembly and Assembly C1.5 and C2.2 Engines for Caterpillar Built Machines

Media Number -UENR3332-01

Publication Date -01/09/2013

Date Updated -07/06/2016

i05298394

Camshaft - Install - Camshaft for C1.5 and C2.2 Engines

SMCS - 1210-012

Installation Procedure

NOTICE

Keep all parts clean from contaminants.

Contaminants may cause rapid wear and shortened component life.

1. Ensure that all components of the camshaft are clean and free from damage. Replace any components of the camshaft that are worn or damaged.
-

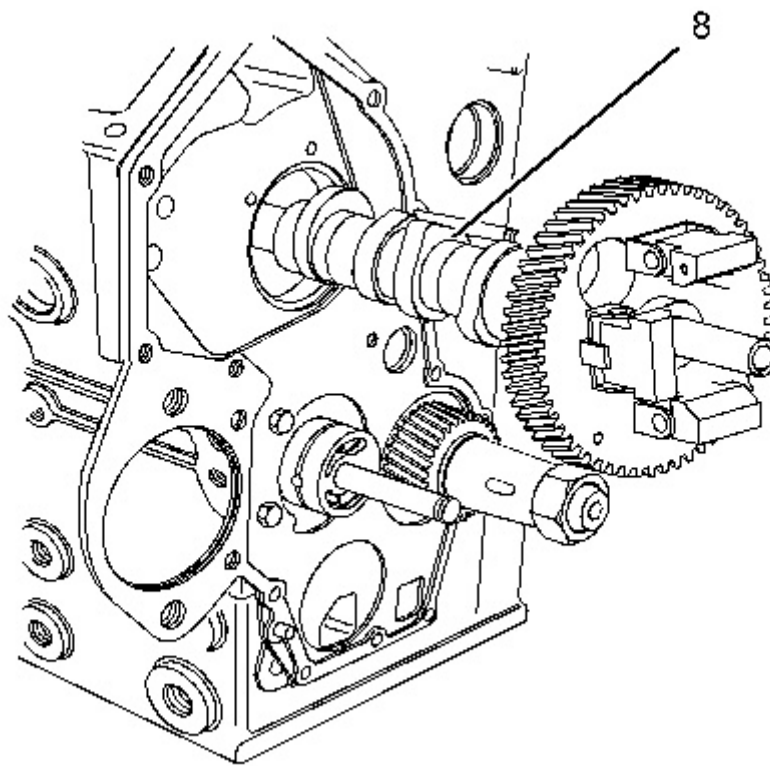

Illustration 1

g03337467

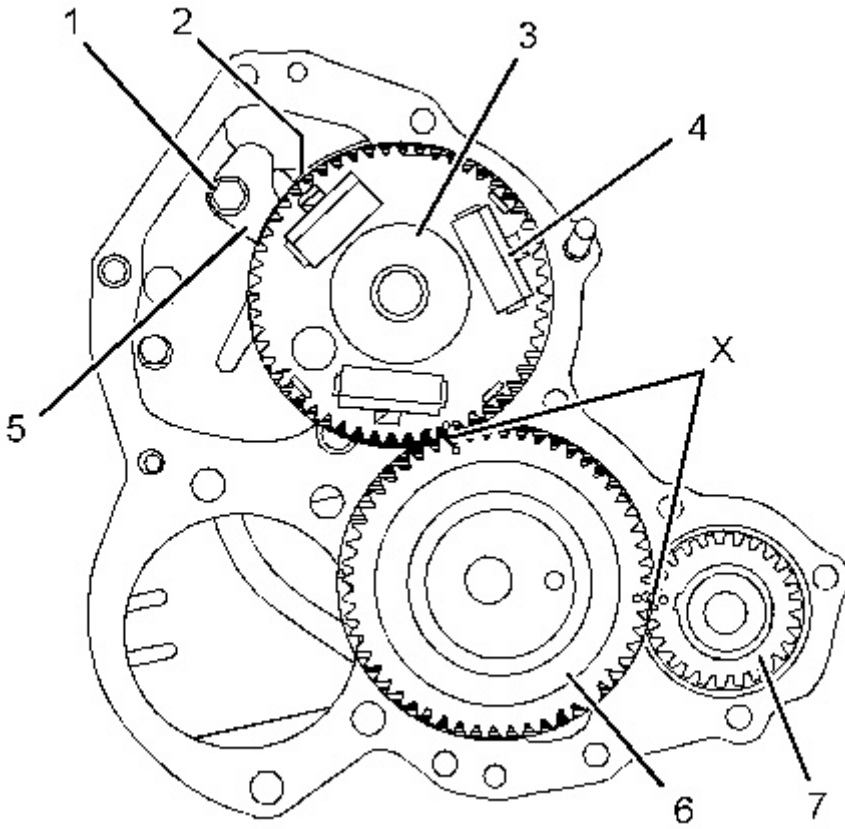

Illustration 2

g03337464

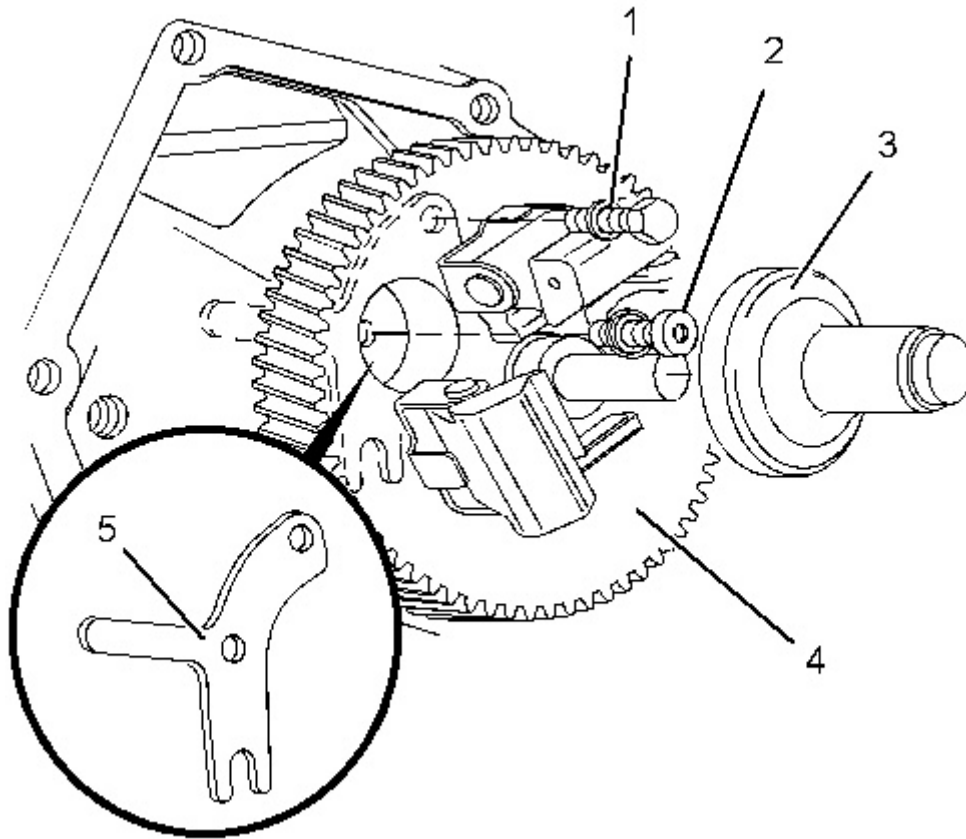

Illustration 3

g03337466

2. Lubricate the bearings of the camshaft with clean engine oil. Carefully install camshaft assembly (8) into the cylinder block. Ensure that timing Marks (X) are aligned with crankshaft gear (7), camshaft gear (4), and idler gear (6).

Note: Do not damage the lobes of the camshaft or the camshaft bearings.

3. Install camshaft retainer (5). Ensure that the holes in the camshaft retainer are aligned with the holes in the cylinder block.

Note: For C1.5 engines have a different camshaft retainer and different fasteners to C2.2 engines. The installation procedure is similar for all models.

4. Rotate camshaft gear (4) in order to align the access hole in the camshaft gear with allen head screw (2) and bolt (1). Install allen head bolt (2) and bolt (1) hand tight.

Note: For C1.5 engines, have allen head bolt (2) and bolt (1) installed.

5. Tighten allen head bolt (2) and bolt (1) to a torque of 10 N·m (89 lb in).

6. Rotate camshaft gear (4) in order to align the access hole in the camshaft gear with bolts (1). Install bolts (1) hand tight.

Note: For C2.2 engines, have bolts (1) installed.

7. Tighten bolts (1) to a torque of 10 N·m (89 lb in).

8. Install slider (3) to camshaft gear (4).

End By:

- a. Install the lifters. Refer to Disassembly and Assembly, "Lifter Group- Remove and Install" for the correct procedure.
 - b. Install the front housing. Refer to Disassembly and Assembly, "Housing (Front) - Install" for the correct procedure.
-

Product: COMPACTOR

Model: CB-34B XW COMPACTOR 425

Configuration: CB34B XW Compactor 42500001-UP (MACHINE) POWERED BY C2.2 Engine

Disassembly and Assembly C1.5 and C2.2 Engines for Caterpillar Built Machines

Media Number -UENR3332-01

Publication Date -01/09/2013

Date Updated -07/06/2016

i05298422

Engine Oil Pan - Remove and Install

SMCS - 1302-010

Removal Procedure

NOTICE

Keep all parts clean from contaminants.

Contaminants may cause rapid wear and shortened component life.

NOTICE

Care must be taken to ensure that fluids are contained during performance of inspection, maintenance, testing, adjusting and repair of the product. Be prepared to collect the fluid with suitable containers before opening any compartment or disassembling any component containing fluids.

Dispose of all fluids according to local regulations and mandates.

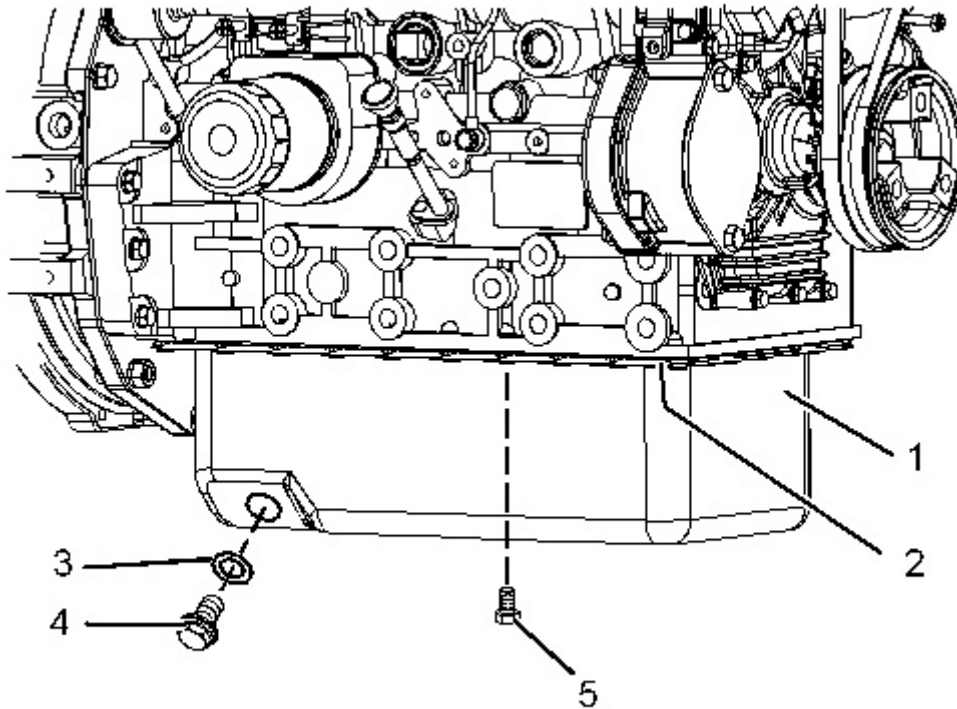

Illustration 1

g03332188

1. Remove plug (4) from engine oil pan (1). Drain the engine oil into a suitable container for storage or disposal. Refer to Operation and Maintenance Manual, "Oil Filter Change" for the correct procedure.
2. Remove sealing washers (3) from plug (4).
3. Remove bolts (5) from engine oil pan (1). Support the engine oil pan as the bolts are removed.
4. Remove engine oil pan (1) from the engine.
5. Remove gasket (1) (not shown).

Installation Procedure

NOTICE

Keep all parts clean from contaminants.

Contaminants may cause rapid wear and shortened component life.

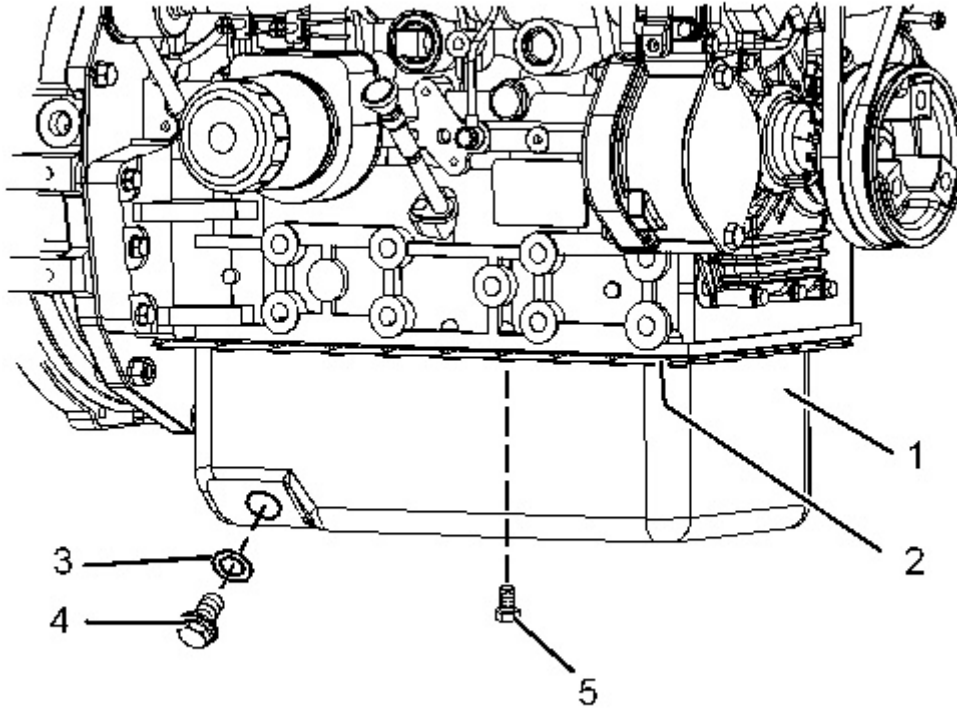

Illustration 2

g03332188

1. Ensure that the engine oil pan is clean and free from damage. Clean the gasket surfaces of the cylinder block and the engine oil pan.
 2. Position a new gasket (2) (not shown) onto engine oil pan (1).
 3. Install engine oil pan (1) onto the cylinder block.
 4. Install bolts (5) hand tight. Support the engine oil pan as the bolts are installed.
 5. Tighten bolts (5) to a torque of 11 N·m (97 lb in).
 6. Install a new washer (3) to plug (4).
 7. Install plug (4) into oil pan (1) hand tight.
 8. Tighten plug (4) to a torque of 34 N·m (301 lb in).
 9. Fill the engine oil pan to the correct level. Refer to Operation and Maintenance Manual, "Engine Oil Filter Change" for the correct procedure.
-

Product: COMPACTOR

Model: CB-34B XW COMPACTOR 425

Configuration: CB34B XW Compactor 42500001-UP (MACHINE) POWERED BY C2.2 Engine

Disassembly and Assembly C1.5 and C2.2 Engines for Caterpillar Built Machines

Media Number -UENR3332-01

Publication Date -01/09/2013

Date Updated -07/06/2016

i05298389

Balancer - Remove

SMCS - 1220-011

Removal Procedure

Start By:

- a. Remove the engine oil pan. refer to Disassembly and Assembly, "Engine Oil Pan - Remove and Install" for the correct procedure.

NOTICE

Keep all parts clean from contaminants.

Contaminants may cause rapid wear and shortened component life.

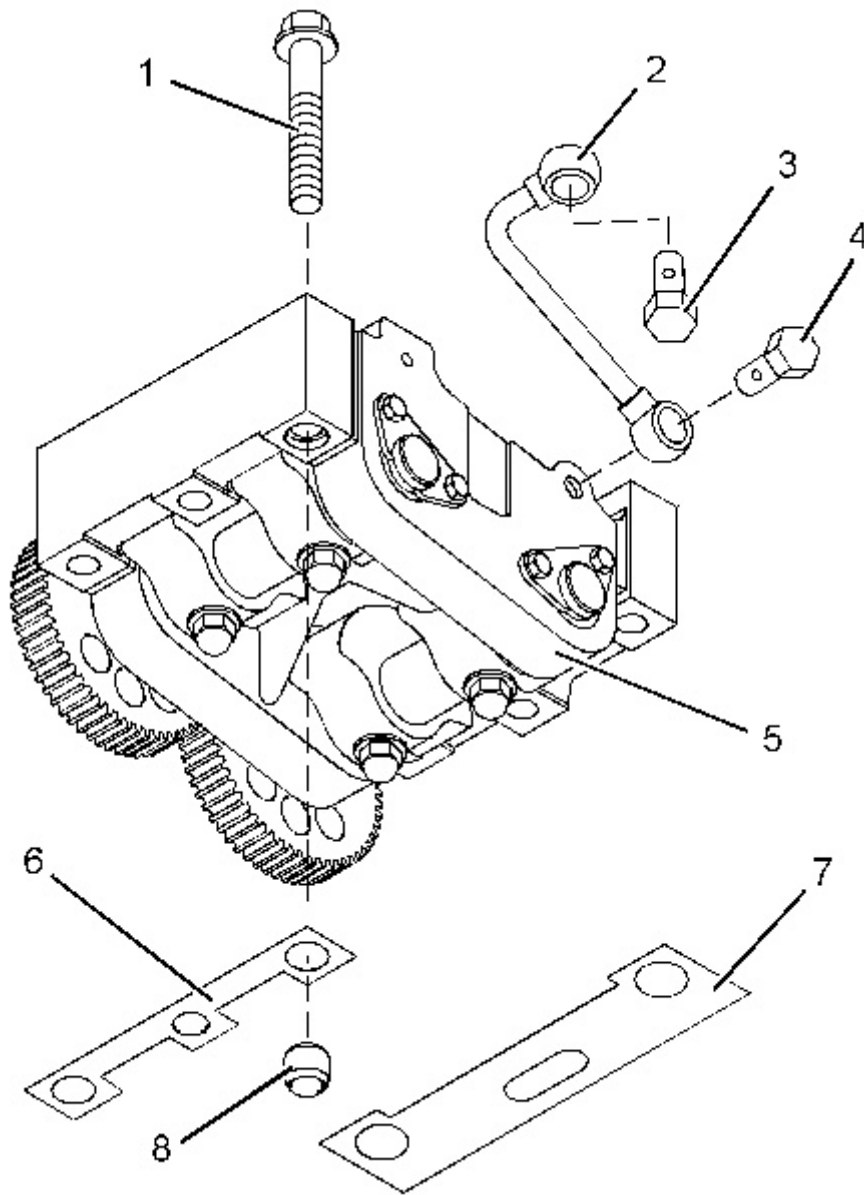

Illustration 1

g03351656

1. Remove banjo bolt (3) and banjo bolt (4) from tube assembly (2).
 2. Remove bolts (1) from balancer assembly (5).
 3. Remove balancer assembly (5) from the cylinder block.
 4. Remove shim (6) and shim (7).
 5. If necessary, remove dowels (8) from the cylinder block. Do not remove the dowels unless the dowels are damaged.
-

Product: COMPACTOR

Model: CB-34B XW COMPACTOR 425

Configuration: CB34B XW Compactor 42500001-UP (MACHINE) POWERED BY C2.2 Engine

Disassembly and Assembly C1.5 and C2.2 Engines for Caterpillar Built Machines

Media Number -UENR3332-01

Publication Date -01/09/2013

Date Updated -07/06/2016

i05298388

Balancer - Install

SMCS - 1220-012

Installation Procedure

NOTICE

Keep all parts clean from contaminants.

Contaminants may cause rapid wear and shortened component life.

1. Ensure that all components of the balance assembly are clean and free from wear or damage. If necessary, replace the balancer as an assembly.
-

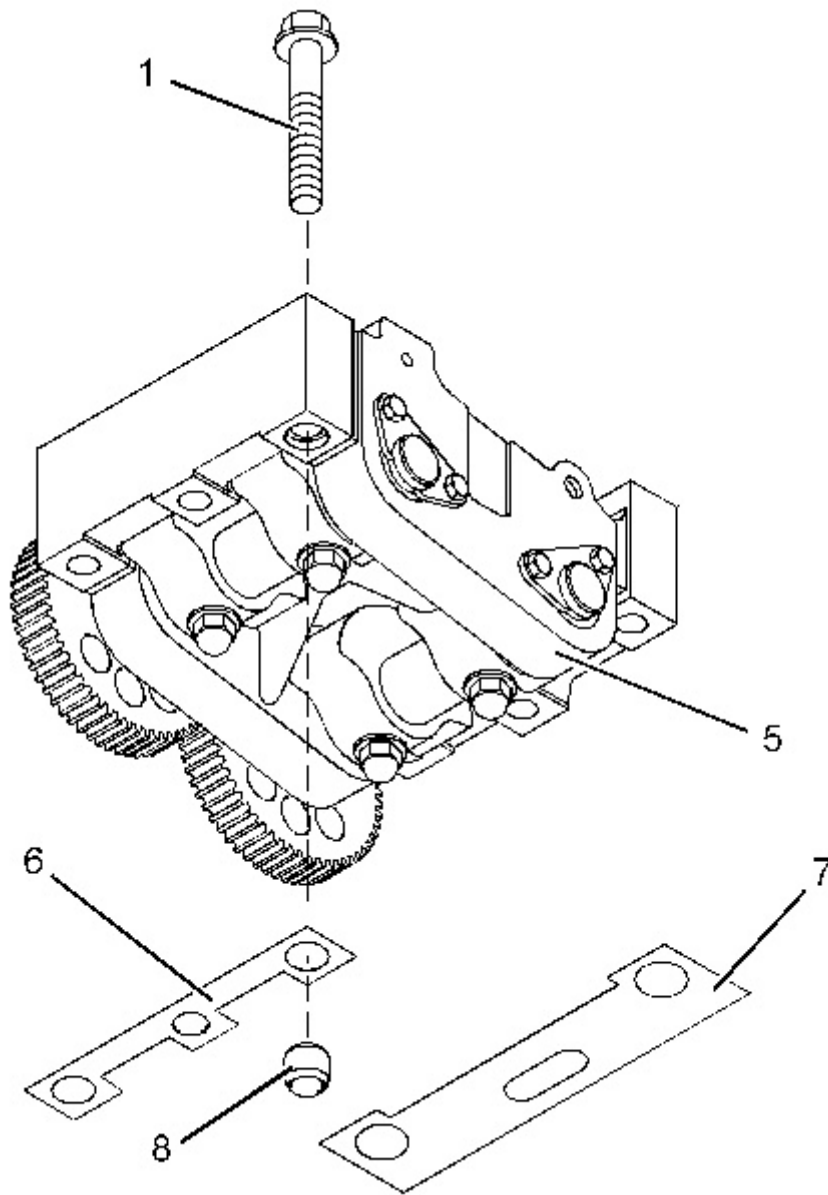

Illustration 1

g03354204

Thank you so much for reading.
Please click the “Buy Now!”
button below to download the
complete manual.



After you pay.

You can download the most
perfect and complete manual in
the world immediately.

Our support email:

ebooklibonline@outlook.com