

Product: VIBRATORY COMPACTOR

Model: CB-44B VIBRATORY COMPACTOR NSL

Configuration: CB54B, CB44B Compactor NSL00001-UP (MACHINE) POWERED BY C4.4 Engine

Disassembly and Assembly CB44B and CB46B Vibratory Asphalt Compactor Machine Systems

Media Number -UENR0173-04

Publication Date -01/05/2017

Date Updated -24/05/2017

i07050502

Piston Motor (Drum Propel) - Disassemble

SMCS - 5058-015

Disassembly Procedure

Table 1

Required Tools			
Tools	Part Number	Part Description	Qty
A	136-1452	Retaining Ring Pliers	1
B	6V-2062	Tips	1
C	1P-0074	Slide Hammer Puller Gp	1
D	4C-5651	Threaded Adapter	1
E	1P-0510	Driver Gp	1
F	8H-0663	Bearing Puller Gp	1
G	426-2717	Reaction Plate	1
	8T-7338	Bolt	4
	9X-8268	Washer	4
H	5F-7339	Adapter	1
J	385-8578	Hydraulic Wrench	1
	385-8589	Reaction Arm Assembly	1
	426-2719	Block Assembly	1
J	132-8126	Hydraulic Wrench ⁽¹⁾	1
	237-3952	Reaction Arm Assembly ⁽²⁾	1

	426-2720	Block Assembly ⁽³⁾	1
K	308-5676	Spanner Wrench Assembly ⁽⁴⁾	1
	329-1669	Spanner Wrench Assembly ⁽⁵⁾	1
	308-5675	Driver Assembly	1
	426-2723	Adapter	1
L	385-8479	Hydraulic Pump Gp 115v	1
	384-8916	Hydraulic Pump Gp 208-240v	1
M	1H-3110	Bearing Puller Gp	1

⁽¹⁾ Can be used in place of 385-8578 Hydraulic Wrench.

⁽²⁾ For use with 132-8126 Hydraulic Wrench only.

⁽³⁾ For use with 132-8126 Hydraulic Wrench only.

⁽⁴⁾ 6 Pin

⁽⁵⁾ 7 Pin

Start By:

- a. Remove the piston motor.

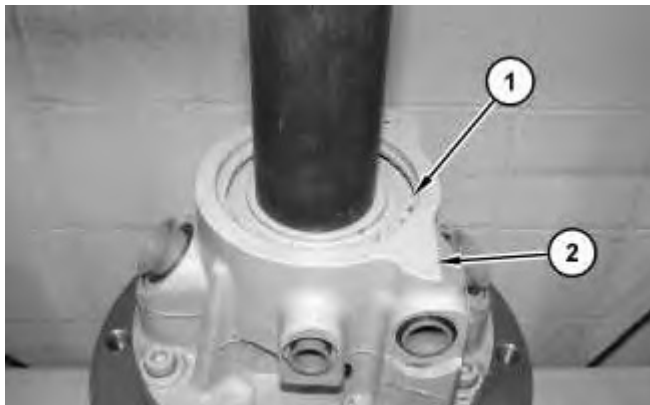

Illustration 1

g03766418



WARNING

Personal injury can result from being struck by parts propelled by a released spring force.

Make sure to wear all necessary protective equipment.

Follow the recommended procedure and use all recommended tooling to release the spring force.

1. Use suitable press, Tooling (A) and (B) to remove retaining ring (1) from head (2).

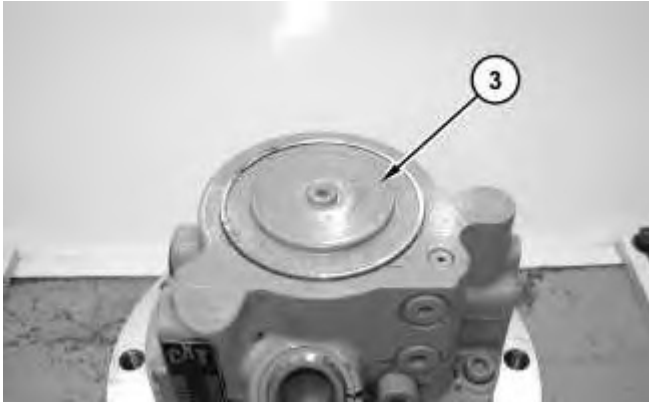

Illustration 2

g03766438

2. Remove plate (3).

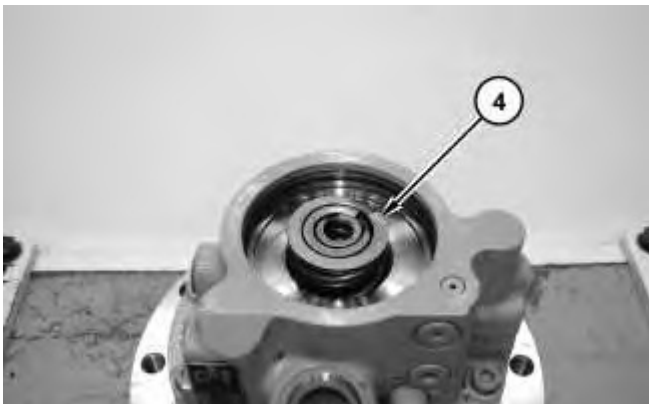

Illustration 3

g03766440

3. Remove springs (4).
-

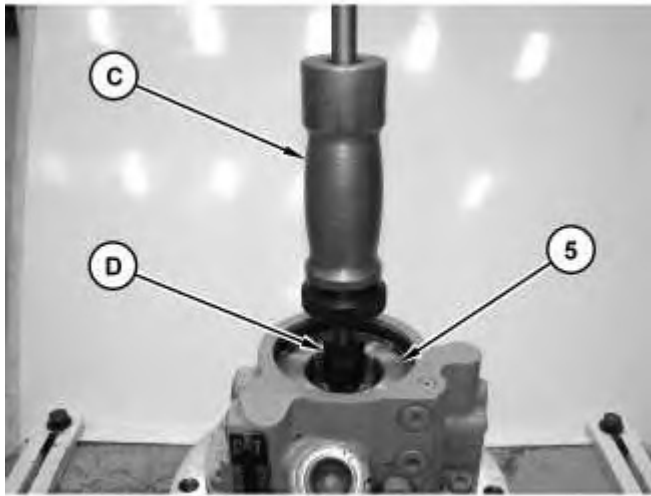

Illustration 4

g03766479

4. Use Tooling (C) and Tooling (D) to remove piston (5).

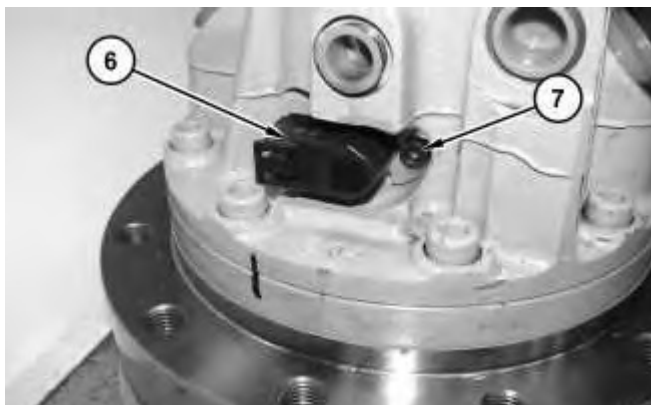

Illustration 5

g03766496

5. Remove bolt (7), speed sensor (6), and the O-ring seal.

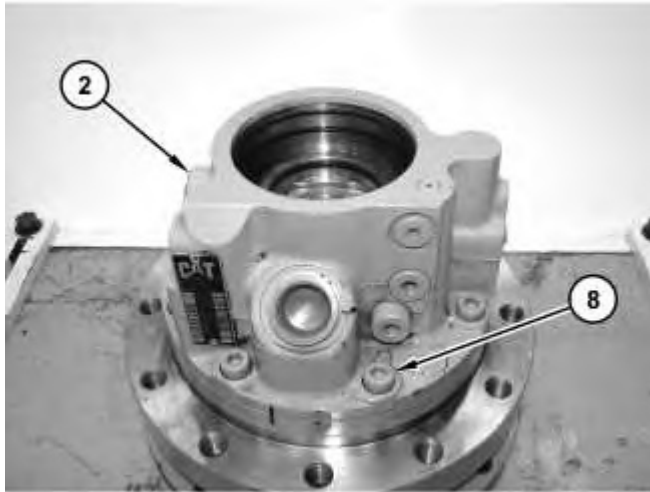

Illustration 6

g03766501

! WARNING

Personal injury can result from being struck by parts propelled by a released spring force.

Make sure to wear all necessary protective equipment.

Follow the recommended procedure and use all recommended tooling to release the spring force.

6. Remove bolts (8) from head (2).

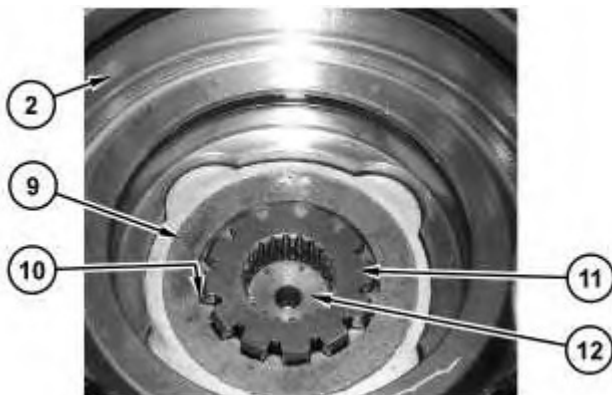

Illustration 7

g03766518

7. Remove head (2) while pushing down on shaft (12) to keep the rotating group from being removed with head (2).

8. Remove friction discs (9), plates (10), and gear (11).

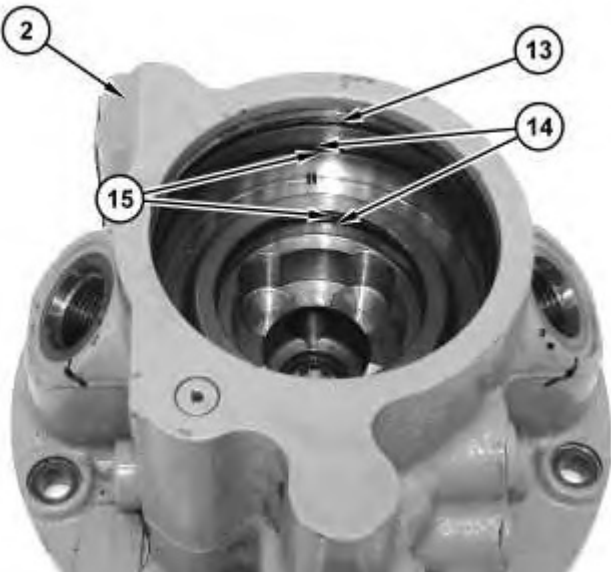

Illustration 8

g03768399

9. Remove O-ring seal (13), backup rings (14), and O-ring seals (15) from head (2).



Illustration 9

g03771136

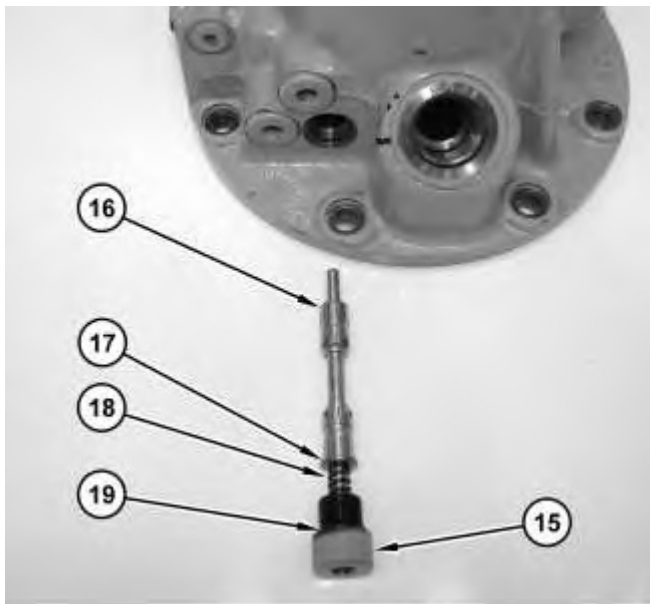

Illustration 10

g03771216

! WARNING

Personal injury can result from being struck by parts propelled by a released spring force.

Make sure to wear all necessary protective equipment.

Follow the recommended procedure and use all recommended tooling to release the spring force.

10. Remove plug (15), O-ring seal (19), spring (18), washer (17), and flushing spool (16) from head (2).

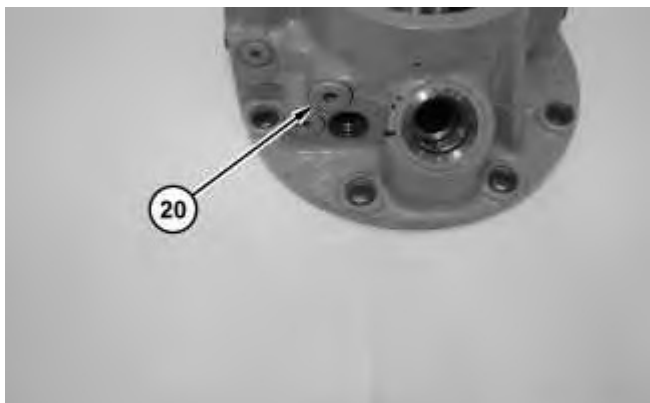

Illustration 11

g03772724

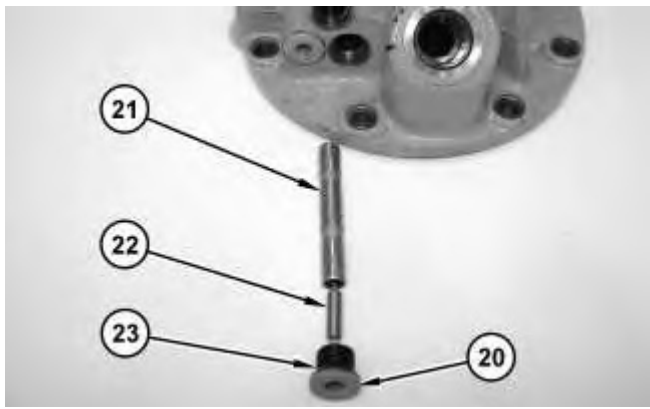

Illustration 12

g03772728

11. Remove plug (20), O-ring seal (23), spool (21), and insert (22).

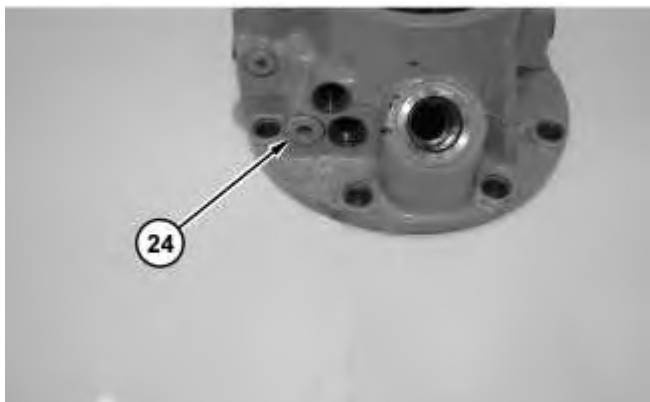

Illustration 13

g03772742

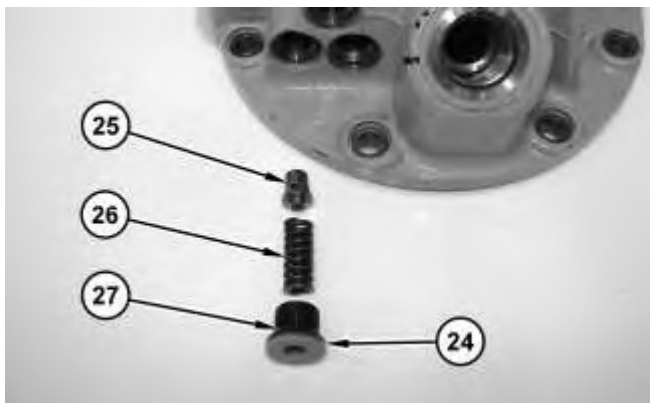

Illustration 14

g03772765

 **WARNING**

Personal injury can result from being struck by parts propelled by a released spring force.

Make sure to wear all necessary protective equipment.

Follow the recommended procedure and use all recommended tooling to release the spring force.

12. Remove plug (24), O-ring seal (27), spring (26), and relief valve (25).

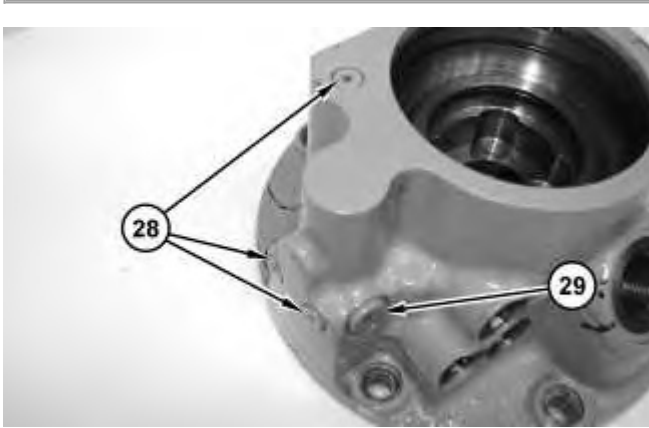

Illustration 15

g03772776

13. Remove plugs (28), plug (29), and the O-ring seals.

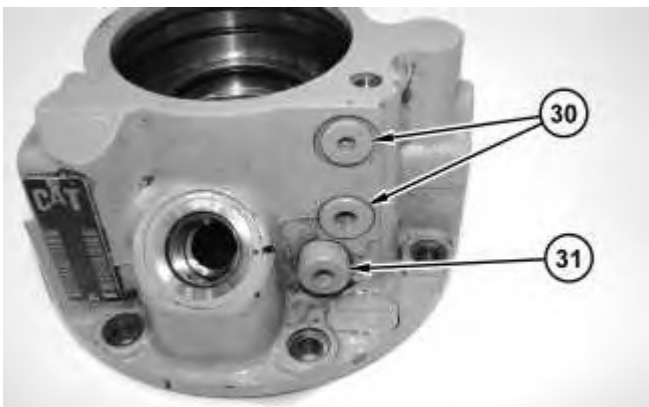
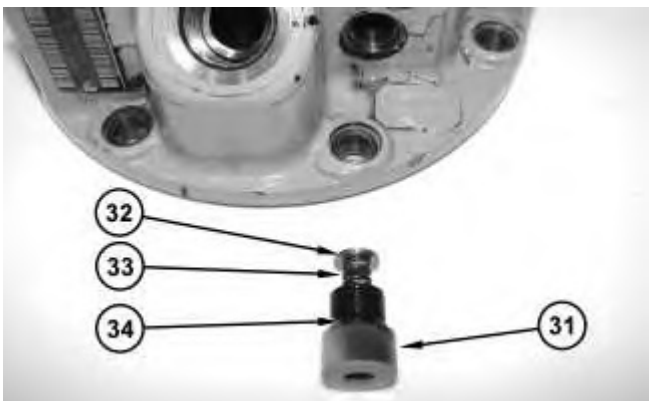

Illustration 16

g03772790



! WARNING

Personal injury can result from being struck by parts propelled by a released spring force.

Make sure to wear all necessary protective equipment.

Follow the recommended procedure and use all recommended tooling to release the spring force.

14. Remove plugs (30) and the O-ring seals.
 15. Remove plug (31), O-ring seal (34), spring (33), and washer (32).
-



Illustration 18

g03773292

16. Remove port plate (35) from head (2).
-



Illustration 19

g03773315

17. Use Tooling (E) to remove seal (37) and bearing (36) from the head.

18. Remove plug (36), O-ring seal (39), spring (38), and valve (37).

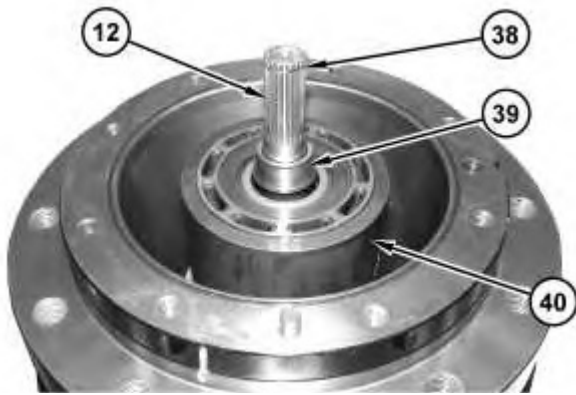

Illustration 20

g03773464

19. Remove shaft assembly (12), clip (38), bearing race (39), and barrel assembly (40).

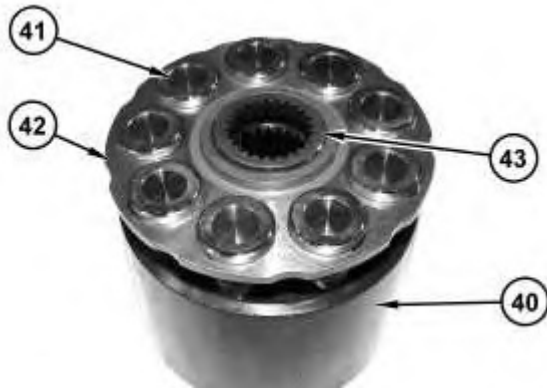

Illustration 21

g03773473

20. Remove piston assemblies (41), retainer (42), and bearing (43) from barrel assembly (40).



Illustration 22

g03773491

21. Remove pins (44) from barrel assembly (40).

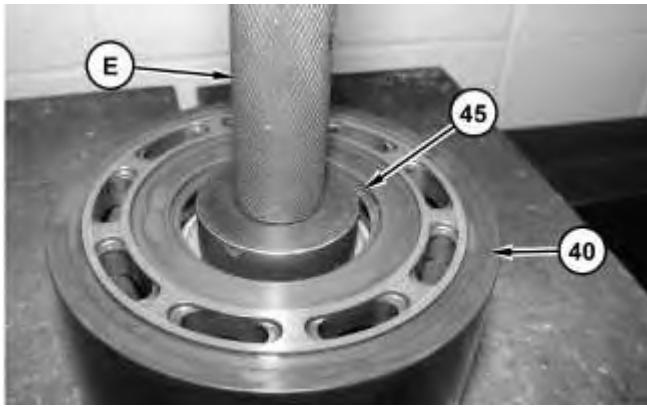

Illustration 23

g03776150

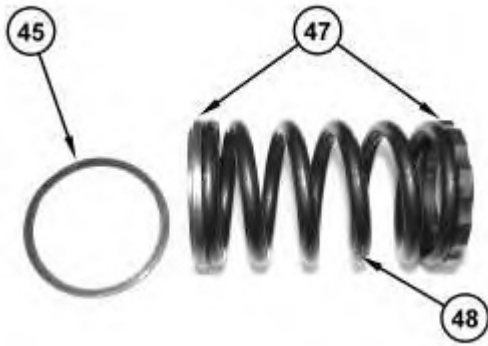

Illustration 24

g03355421

 **WARNING**

Personal injury can result from being struck by parts propelled by a released spring force.

Make sure to wear all necessary protective equipment.

Follow the recommended procedure and use all recommended tooling to release the spring force.

-
22. Use Tooling (E) and a suitable press to compress spring (48).
 23. Remove retaining ring (45), retainers (47), and spring (48) from barrel assembly (40).
-



Illustration 25

g03362974

24. Remove swashplate (49).

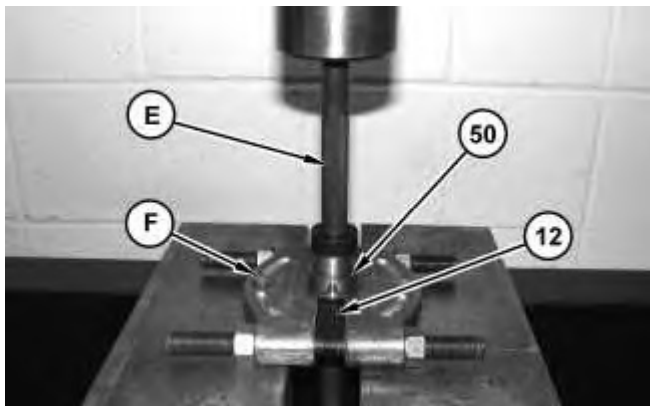

Illustration 26

g03776159

25. Use Tooling (E) and Tooling (M) to remove bearing race (50) from shaft (12).



Illustration 27

g03776175

26. Remove guides (51) and bearing (52).

27. Remove O-ring seals (53) and (54).

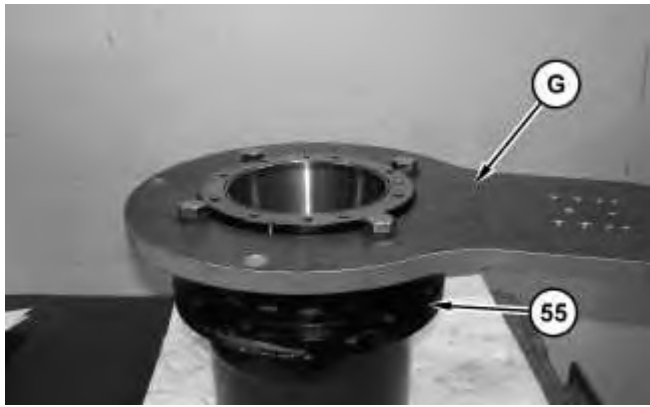

Illustration 28

g03355485

28. Attach Tooling (G) to housing (55).



Illustration 29

g03355473

29. Use Tooling (B) to remove retaining ring (56).
30. Remove plug (57) and the O-ring seal.

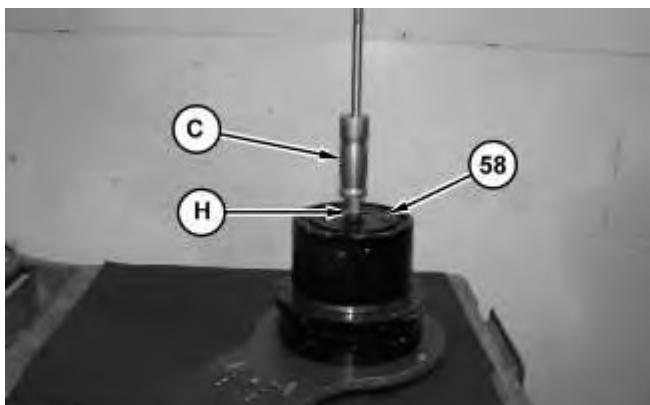

Illustration 30

g03355503

31. Use Tooling (C) and Tooling (H) to remove cover (58).

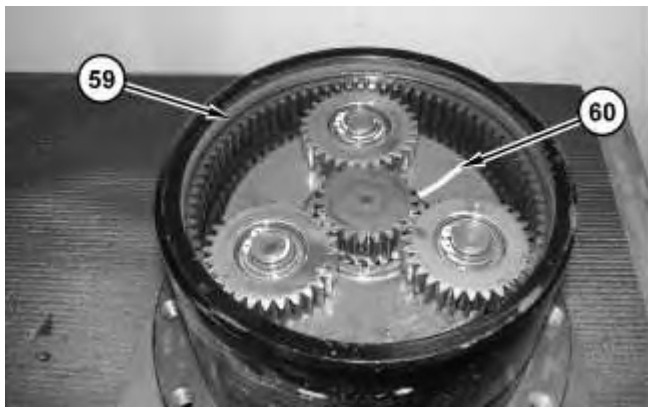

Illustration 31

g03355505

32. Remove O-ring seal (59) and carrier assembly (60).



Illustration 32

g03355791

33. Remove gear (61). Remove retaining rings (62). Remove gears (63).
34. Remove retaining ring (64) and gear (65).

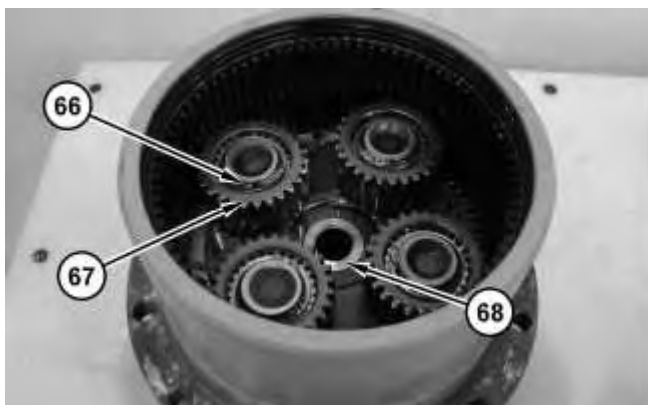

Illustration 33

g03727570

35. Remove retaining rings (66). Remove gears (67).
36. Remove bearing race (68).

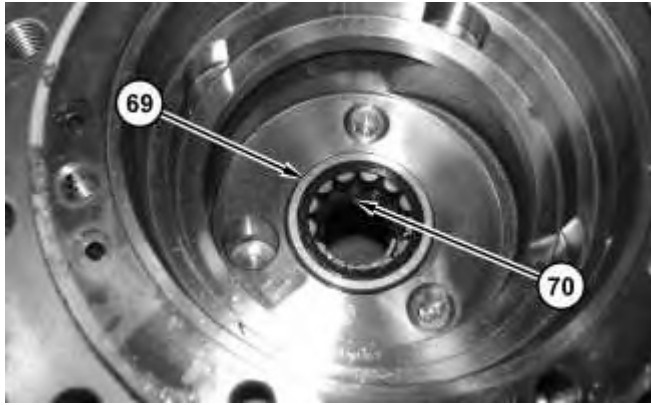

Illustration 34

g03362981

37. Use Tooling (E) to remove bearing (69) and shaft seal (70).

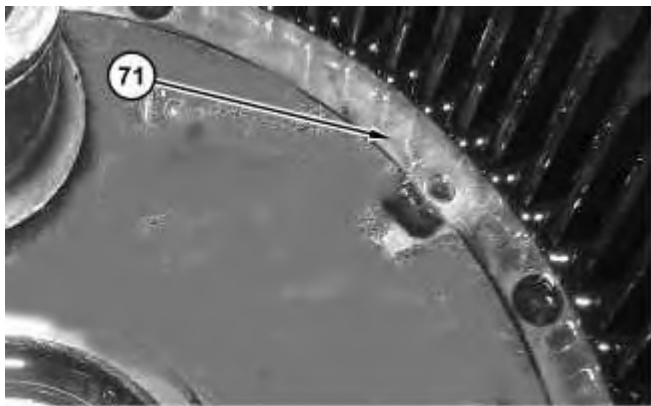

Illustration 35

g03355806

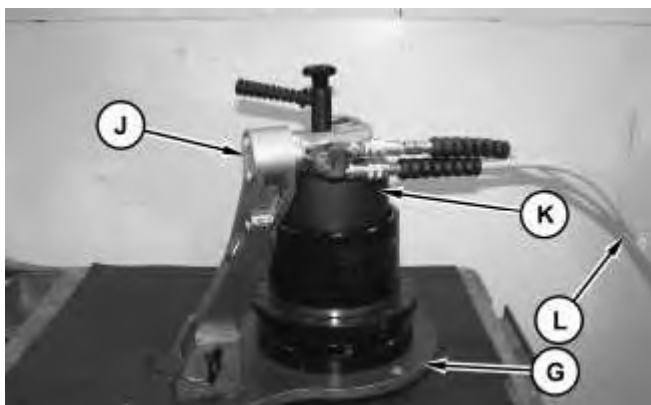

Illustration 36

g03355801

38. Drill the stakes from nut (71). Install Tooling (K). Attach Tooling (J) and Tooling (L) to Tooling (K) and Tooling (G).
39. Remove nut (71) from the spindle.
-

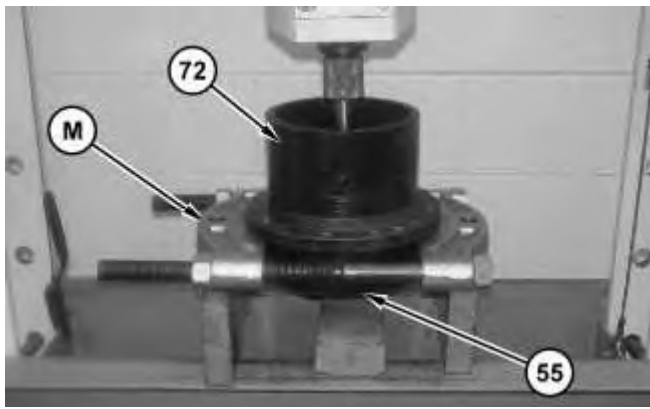

Illustration 37

g03355938

40. Use Tooling (M) and a suitable press to remove spindle (72) from housing (55).

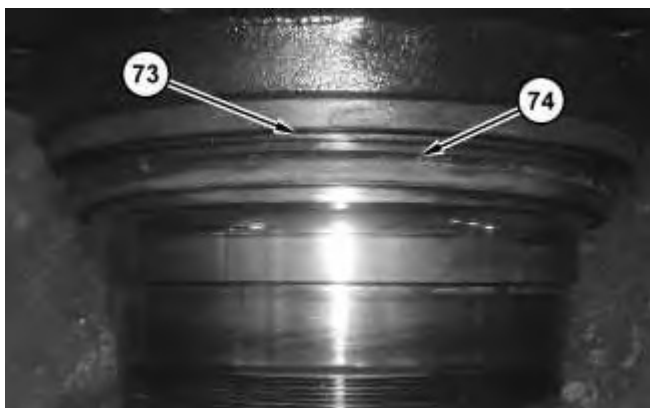

Illustration 38

g03355939



Illustration 39

g03775471

41. Remove Duo-Cone seals (73) and (74).

Product: VIBRATORY COMPACTOR

Model: CB-44B VIBRATORY COMPACTOR NSL

Configuration: CB54B, CB44B Compactor NSL00001-UP (MACHINE) POWERED BY C4.4 Engine

Disassembly and Assembly CB44B and CB46B Vibratory Asphalt Compactor Machine Systems

Media Number -UENR0173-04

Publication Date -01/05/2017

Date Updated -24/05/2017

i07050506

Piston Motor (Drum Propel) - Assemble

SMCS - 5058-016

Assembly Procedure

Table 1

Required Tools			
Tools	Part Number	Part Description	Qty
A	136-1452	Retaining Ring Pliers	1
B	6V-2062	Tips	1
C	1P-0074	Slide Hammer Puller Gp	1
D	4C-5651	Threaded Adapter	1
E	1P-0510	Driver Gp	1
F	8H-0663	Bearing Puller Gp	1
G	426-2717	Reaction Plate	1
	8T-7338	Bolt	4
	9X-8268	Washer	4
H	5F-7339	Adapter	1
J	385-8578	Hydraulic Wrench	1
	385-8589	Reaction Arm As	1
	426-2719	Block Assembly	1
J	132-8126	Hydraulic Wrench ⁽¹⁾	1
	237-3952	Reaction Arm Assembly ⁽²⁾	1

	426-2720	Block Assembly ⁽³⁾	1
K	308-5676	Spanner Wrench Assembly ⁽⁴⁾	1
	329-1669	Spanner Wrench Assembly ⁽⁵⁾	1
	308-5675	Driver Assembly	1
	426-2723	Adapter	1
	385-8479	Hydraulic Pump Gp 115v	1
L	384-8916	Hydraulic Pump Gp 208-240v	1
M	1H-3110	Bearing Puller Gp	1
N	FT-3318	Tool Gp	1

⁽¹⁾ Can be used in place of 385-8578 Hydraulic Wrench.

⁽²⁾ For use with 132-8126 Hydraulic Wrench only.

⁽³⁾ For use with 132-8126 Hydraulic Wrench only.

⁽⁴⁾ 6 Pin

⁽⁵⁾ 7 Pin

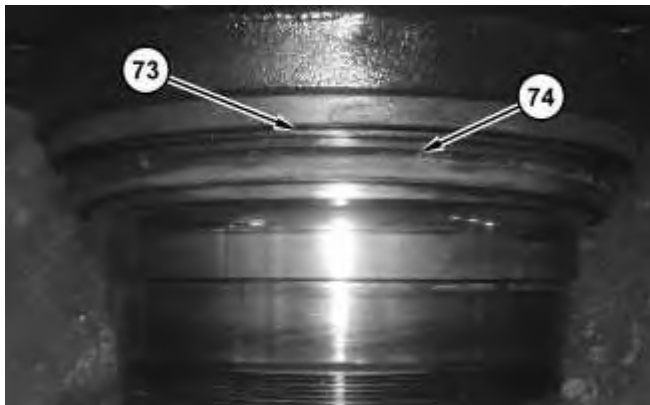

Illustration 1

g03355939

1. Install Duo-Cone seals (73) and (74).

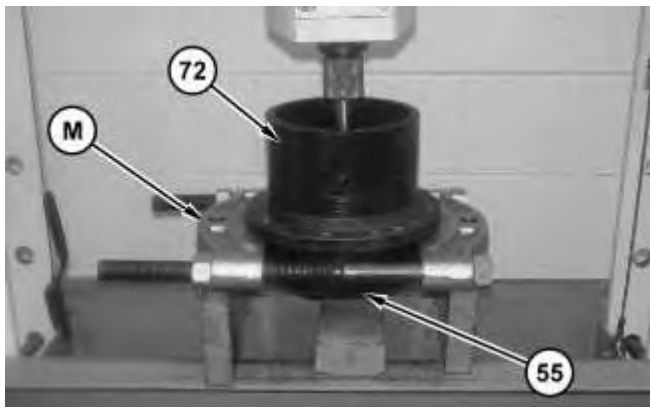

Illustration 2

g03355938

2. Use Tooling (M) and a suitable press to install spindle (72) onto housing (55).

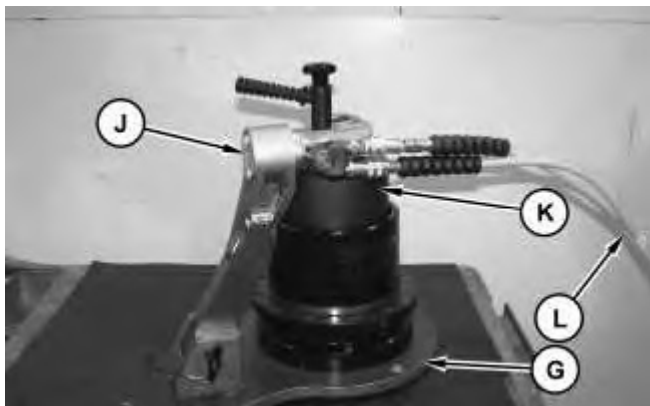

Illustration 3

g03355801

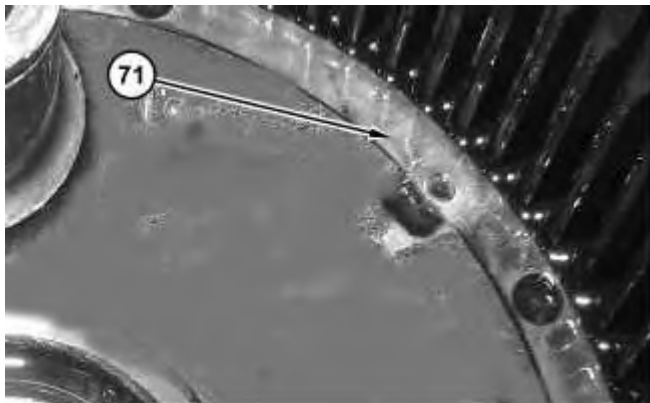

Illustration 4

g03355806

3. Install nut (71) from the spindle.
Note: Shown with nut (71) staked. Do not stake now.
4. Install Tooling (K). Attach Tooling (J) and Tooling (L) to Tooling (K) and Tooling (G).
5. Tighten nut (71) to a torque of $3900 \pm 100 \text{ N}\cdot\text{m}$ ($2877 \pm 74 \text{ lb ft}$).

6. Stake nut (71) into place.

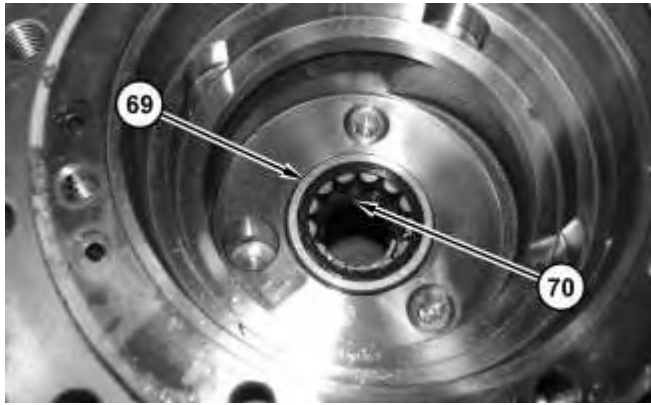

Illustration 5

g03362981

7. Use Tooling (E) to install bearing (69) and shaft seal (70).

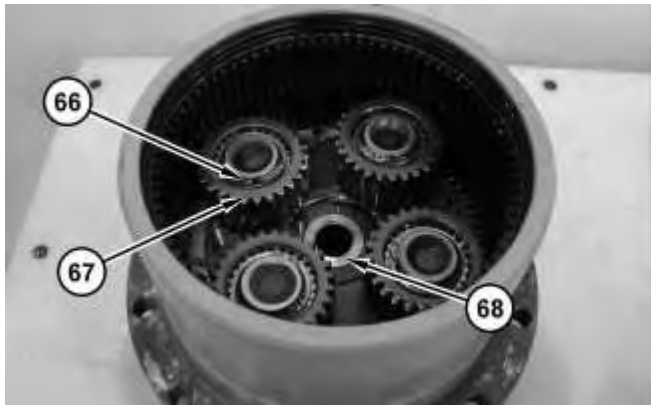

Illustration 6

g03727570

8. Install bearing race (68).

9. Install retaining rings (66). Install gears (67).



Illustration 7

g03355791

10. Install retaining ring (64) and gear (65).
11. Install gear (61). Install retaining rings (62). Install gears (63).



Illustration 8

g03355505

12. Install O-ring seal (59) and carrier assembly (60).
13. Install cover (58).



Illustration 9

g03355473

14. Install plug (57) and the O-ring seal.
15. Use Tooling (B) to install retaining ring (56).

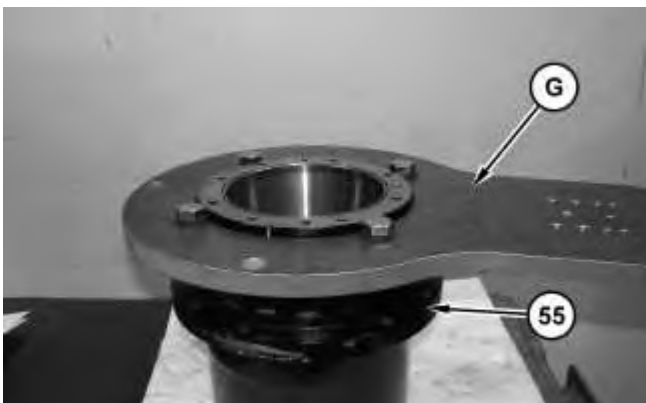

16. Remove Tooling (G) from housing (55).

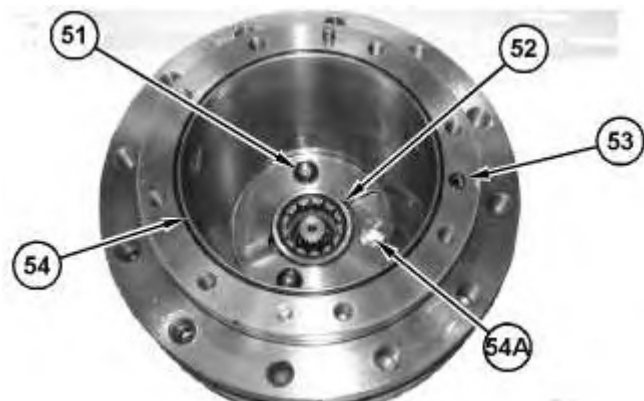

Typical Example



Improper assembly of parts that are spring loaded can cause bodily injury.

To prevent possible injury, follow the established assembly procedure and wear protective equipment.

17. Install O-ring seals (53) and (54).

18. Install guides (51), the spring, piston (54A), and bearing (52).

19. Install Tooling (N1) to hold and position piston (54A).

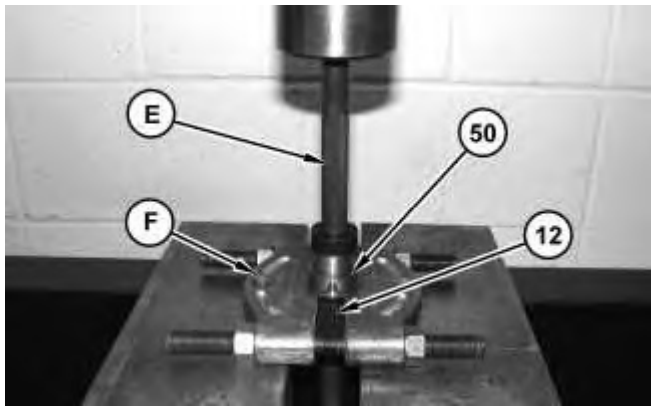

Illustration 13

g03776159

20. Use Tooling (E) and Tooling (M) to install bearing race (50) from shaft (12).



Illustration 14

g03362974

21. Install swashplate (49).

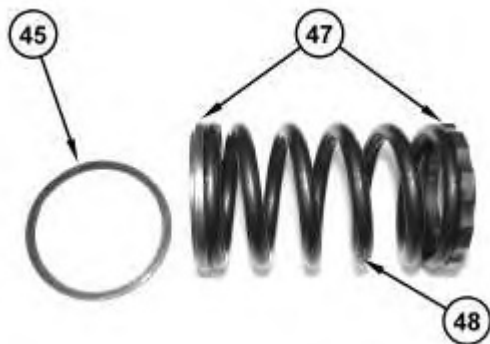

Illustration 15

g03355421

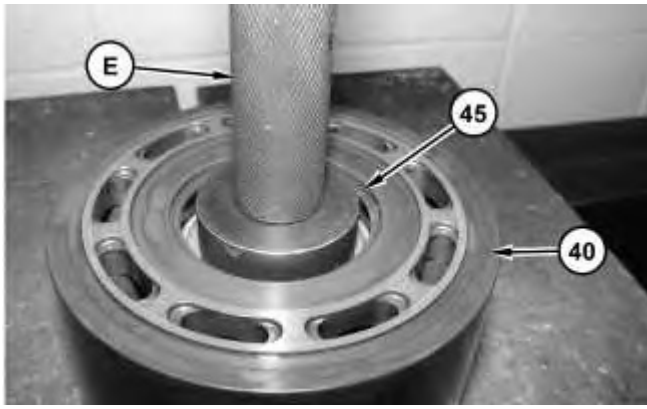

Illustration 16

g03776150

WARNING

Improper assembly of parts that are spring loaded can cause bodily injury.

To prevent possible injury, follow the established assembly procedure and wear protective equipment.

22. Install retaining ring (45), retainers (47), and spring (48) from barrel assembly (40).
23. Use Tooling (E) and a suitable press to compress spring (48).



Illustration 17

g03773491

24. Install pins (44) from barrel assembly (40).



Illustration 18

g03773473

25. Install piston assemblies (41), retainer (42), and bearing (43) from barrel assembly (40).

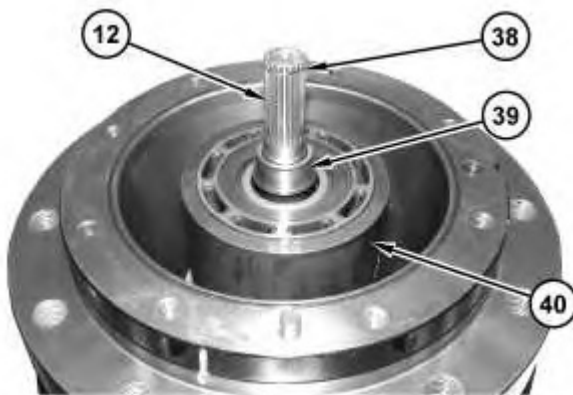

Illustration 19

g03773464



Illustration 20

g06207515

Typical Example

26. Install shaft assembly (12), clip (38), bearing race (39), and barrel assembly (40).
27. Install Tooling (N2) to keep barrel assembly (40) from tilting and lifting.



Illustration 21
Typical Example

g06207519

28. Remove Tooling (N1) from the motor.



Illustration 22

g03773315

29. Install plug (36), O-ring seal (39), spring (38), and valve (37).

30. Use Tooling (E) to install seal (37) and bearing (36) from the head.



Illustration 23

g03773292

31. Install port plate (35) from head (2).

Thank you so much for reading.
Please click the “Buy Now!”
button below to download the
complete manual.



After you pay.

You can download the most
perfect and complete manual in
the world immediately.

Our support email:

ebooklibonline@outlook.com