

Product: VIBRATORY COMPACTOR

Model: CP-323 VIBRATORY COMPACTOR 6JD

Configuration: CP-323 VIBRATORY COMPACTOR 6JD00001-00065 (MACHINE) POWERED BY 4219D ENGINE

Disassembly and Assembly CP/CS-323 VIBRATORY COMPACTORS VEHICLE SYSTEMS

Media Number -KENR1607-00

Publication Date -01/06/1990

Date Updated -10/10/2001

Vibratory Motor

SMCS - 5061-010; 5061-017

Remove & Install Vibratory Motor

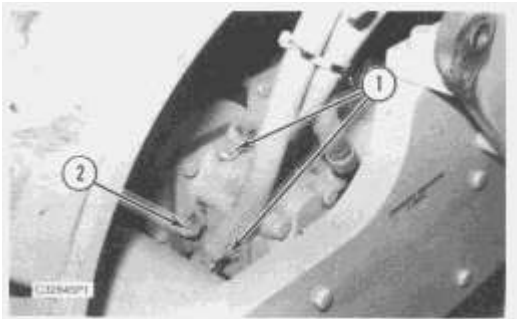

1. Disconnect and plug three hoses (1).
2. Remove four bolts (2) and the vibratory motor.

NOTE: The following steps are for the installation of the vibratory motor.

3. Install the vibratory motor with four bolts (2). Tighten the bolts to a torque of **100 ± 13 N·m (75 ± 10 lb ft)**.
4. Connect three hoses (1).

Disassemble & Assemble Vibratory Motor

Start By:

a. remove vibratory motor

1. Put marks across the end covers and housing of the vibratory motor for correct alignment at assembly.

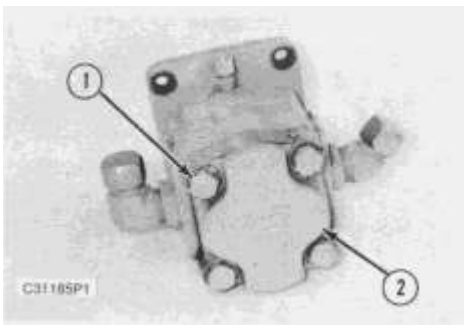

2. Remove four bolts (1) and port end cover (2).

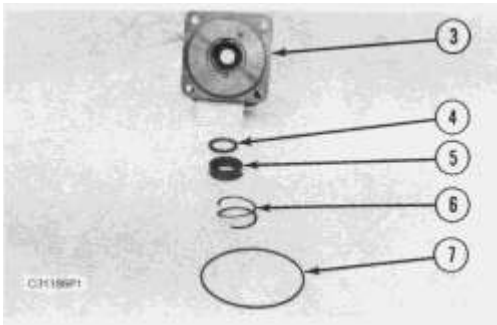

3. Remove O-ring seal (7) from shaft cover (3). Check the O-ring seals for wear or damage. Replace as required.

4. Remove spiral snap ring (6), spacer (5) and seal retainer (4).

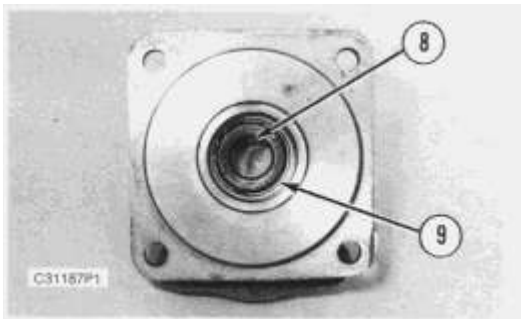

5. Remove ring seal (9) and lip seal (8).

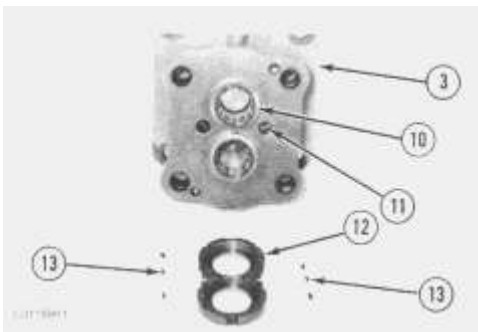

6. Remove thrust plate (12) and twelve pocket seals (13) from shaft cover (3).

7. Remove two check assemblies (11) and two roller bearings (10).

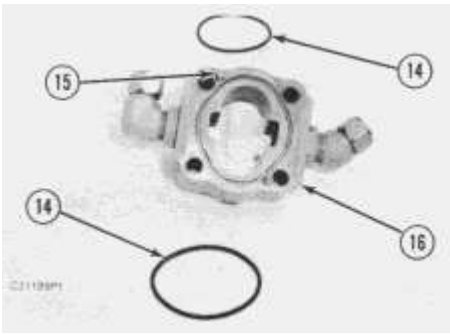

8. Remove two gasket seals (14) from housing (16).

9. If necessary, remove two dowel pins (15).

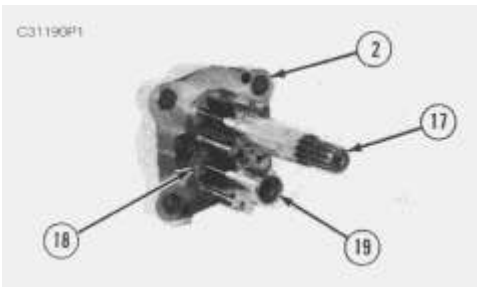

NOTE: Drive gear (17) and idler gear (19) are a matched set. They are not serviced separately.

10. Mark the locations of drive gear (17) and idler gear (19) in port end cover (2) for assembly purposes. Remove the drive gear and the idler gear from the port end cover. Remove thrust plate (18) and the twelve pocket seals.

11. Make sure all of the parts are clean and coat with clean hydraulic oil.

NOTE: The following steps are for the assembly of the vibratory motor.

12. Install the twelve pocket seals and thrust plate (18).

NOTE: Drive gear (17) and idler gear (19) are a matched set. They are not serviced separately.

13. Install idler gear (19) and drive gear (17) using the markings made during disassembly to align them properly in port end cover (2).

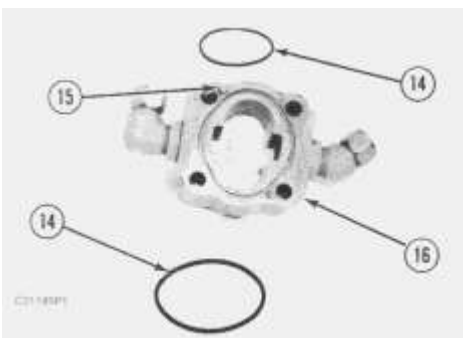

14. If previously removed, install two dowel pins (15).

15. Install two gasket seals (14) in housing (16).

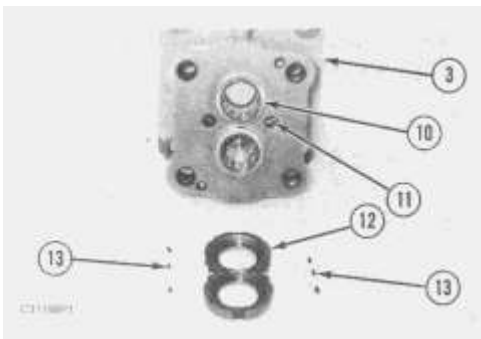

16. Install two roller bearings (10) and two check assemblies (11).

17. Install twelve pocket seals (13) and thrust plate (12) in shaft cover (3).

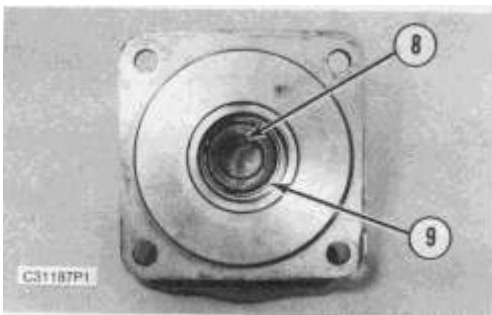

18. Install lip seal (8) and ring seal (9).

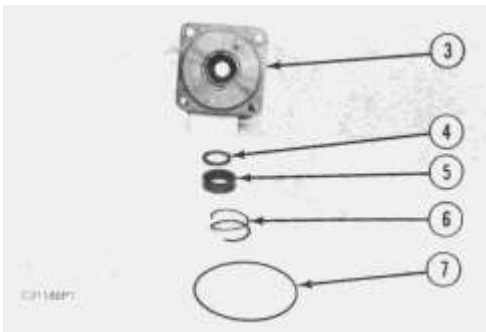

19. Install O-ring seal (7) in shaft cover (3).

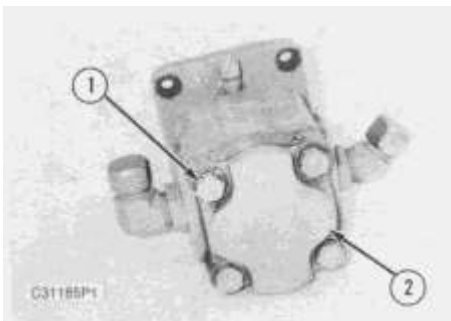

20. Align the marks on the vibratory motor housing and port end cover (2). Install port end cover (2) with four bolts (1).

End By:

a. install vibratory motor

Product: VIBRATORY COMPACTOR

Model: CP-323 VIBRATORY COMPACTOR 6JD

Configuration: CP-323 VIBRATORY COMPACTOR 6JD00001-00065 (MACHINE) POWERED BY 4219D ENGINE

Disassembly and Assembly CP/CS-323 VIBRATORY COMPACTORS VEHICLE SYSTEMS

Media Number -KENR1607-00

Publication Date -01/06/1990

Date Updated -10/10/2001

Drum

SMCS - 4206-010; 4206-017

Remove & Install Drum

NOTE: Mark all hoses as to their location for assembly purposes.

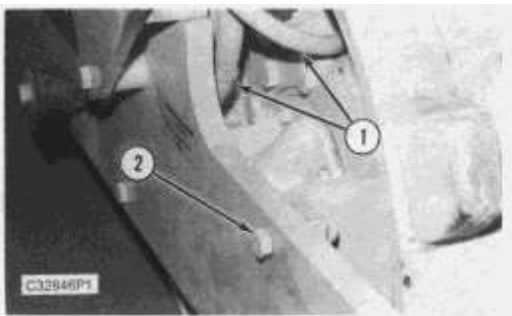

1. Disconnect and cap three hose assemblies (1) from the drum drive motor.
2. Remove four bolts (2).

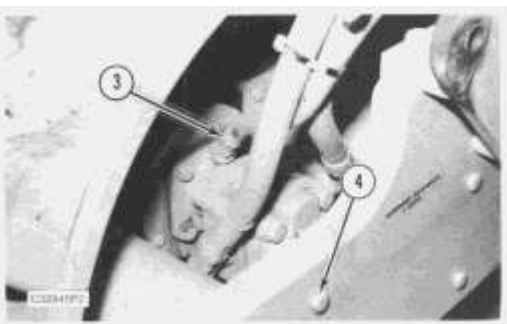

3. Disconnect and cap three hose assemblies (3) from the vibratory motor.

NOTE: Do not loose the shock mount spacer located between the shock mount and the inside of the yoke assembly.

4. Remove eight bolts (4) that hold the shock mount to the inside of the yoke.

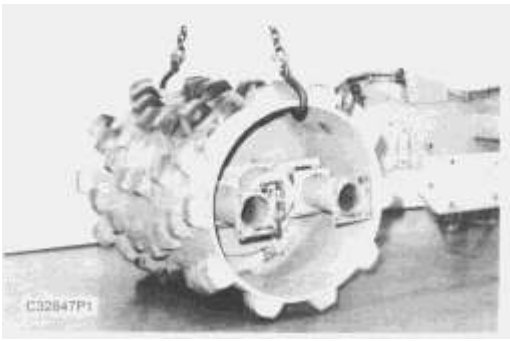

WARNING

Be prepared to block the drum once it is removed from the machine. If the drum is free to travel, personal injury may result.

5. Make sure the drum is completely disconnected from the yoke. Attach a hoist to the drum. Lift the drum from the machine. The weight of the drum is **1365 kg (3000 lb)**.

NOTE: The following steps are for the installation of the drum.

6. Attach the drum to a hoist and install it into the machine.

7. Position the shock mount spacer between the shock mount and the yoke assembly. Install eight bolts (4) and tighten to a torque of **100 ±13 N·m (75 ± 10 lb ft)**.

8. Connect three hose assemblies (3) to the vibratory motor.

9. Install four bolts (2) and tighten to a torque of **355 ± 48 N·m (265 ± 35 lb ft)**.

10. Connect three hose assemblies (1) to the drum drive motor.

11. Check the hydraulic fluid level. See the "Operation & Maintenance Guide".

Disassemble & Assemble Drum

Start By:

- a. remove drum
- b. remove drum drive motor
- c. remove vibratory motor
- d. remove vibratory arm

| Tools Needed | | A | B | C |
|--------------|-----------------|---|---|---|
| 6V2157 | Link Bracket | 2 | | |
| FT0884 | Leg | | 2 | |
| 8B7554 | Puller Assembly | | 1 | |
| 9S9155 | Spacer | | 1 | |
| 5F7345 | Screw | | 1 | |
| 1P5546 | Crossblock | | | 1 |
| 1P0546 | Jaw | | | 2 |
| 5H9976 | Screw | | | 1 |

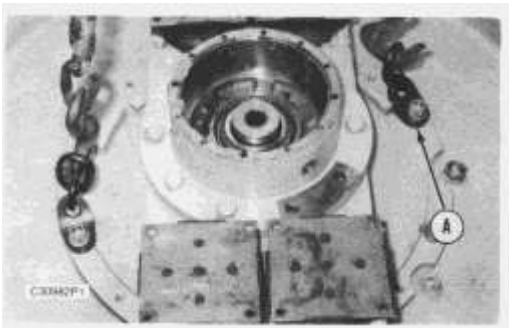

Typical Example

! WARNING

Do not move the drum without securing proper lifting device. Lifting the drum assembly without using the proper link brackets and hoist can cause the drum assembly to spin and fall. This can result in personal injury or equipment damage. Be sure the work area is clear before the drum assembly is moved.

1. Install tooling (A) and a hoist. Position the drum on its end, (vertically), with the vibratory end at the top. The weight of the drum is **approximately 1365 kg (3000 lb)**.

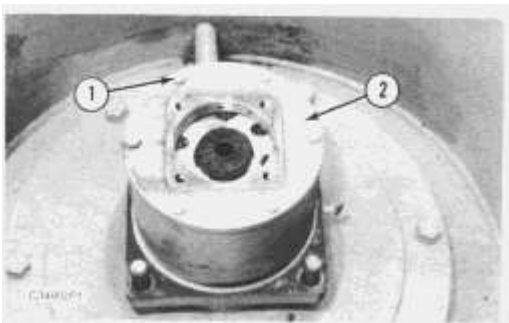

2. Remove six bolts (1) and motor mounting plate (2).

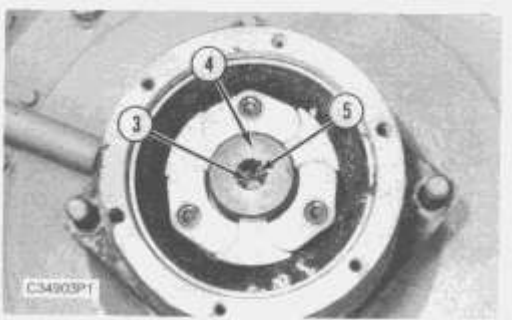

NOTE: When turning out puller bolt (3), snap ring (5) may pop out. This will leave half of the coupling assembly on the weight shaft.

3. Turn out puller bolt (3). Remove insert assembly (4).

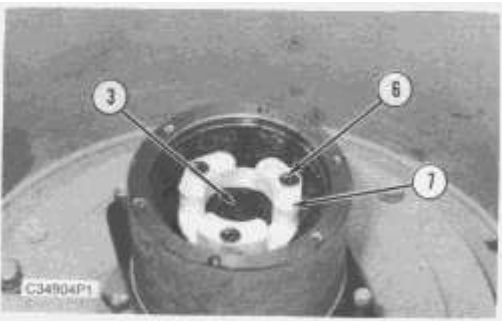

4. Remove three screws (6), hytrel element (7) and puller bolt (3).

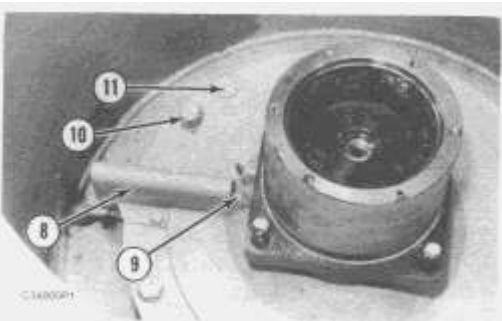

5. Remove the two bolts and hose guard (8). Disconnect and plug hose assembly (9).

6. Remove bolts (10) that hold the stub shaft to the drum.

7. Remove corks (11) from the puller holes in the stub shaft and install three $1 \times 3 \frac{1}{2}$ forcing screws.

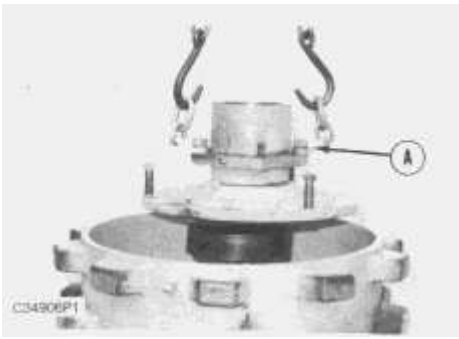

8. Turn the forcing bolts equally until the stub shaft is free of the drum.

9. Install tooling (A) and attach a hoist. Remove the stub shaft. The weight of the stub shaft is **159 kg (350 lb)**.

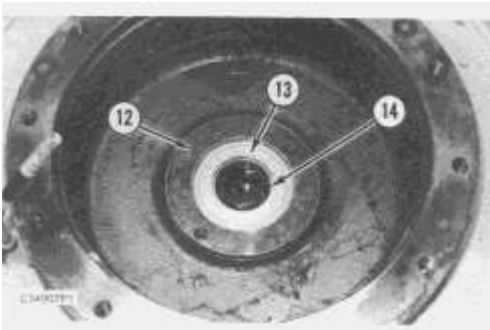

10. Remove the screws and retainer plate (12).

11. Remove seal (13) and bearing (14) from the eccentric weight housing.

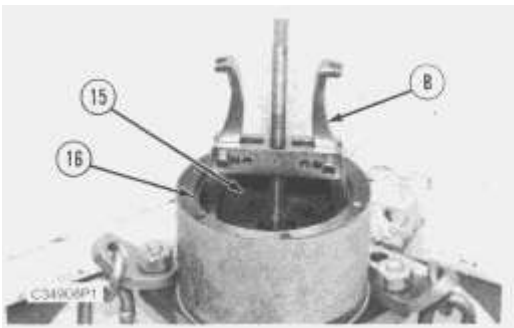

12. Remove the key from the shaft. If necessary, use tool (B) and remove flange hub (15).

13. Remove bearing spacer (16).

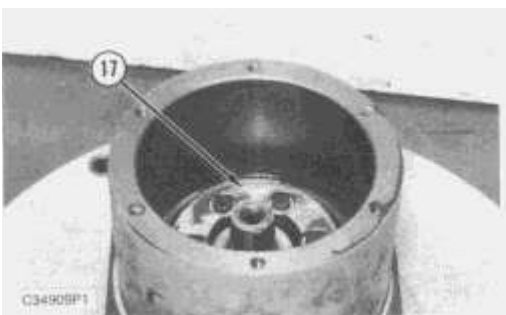

14. Remove the bolts and retaining plate (17). Remove the bearing.

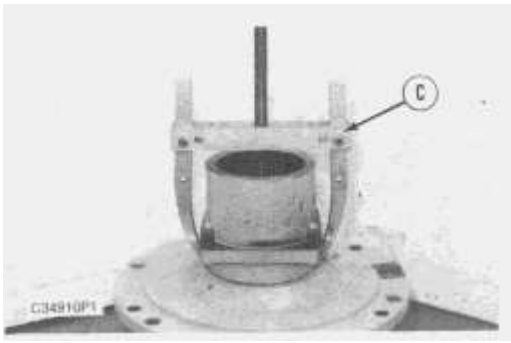

15. Using tooling (C), remove the hub from the shaft.

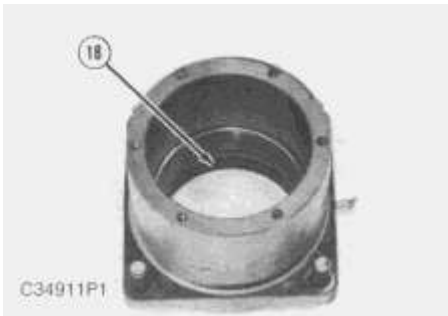

16. Remove ring wiper (18) from the hub.

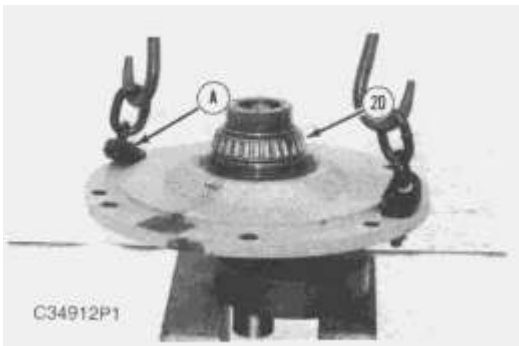

17. Install tooling (A) on the stub shaft. Remove the stub shaft from the eccentric weight. The weight of the stub shaft is **91 kg (200 lb)**. The weight of the eccentric weight is **34 kg (75 lb)**.

18. Remove bearing (19).

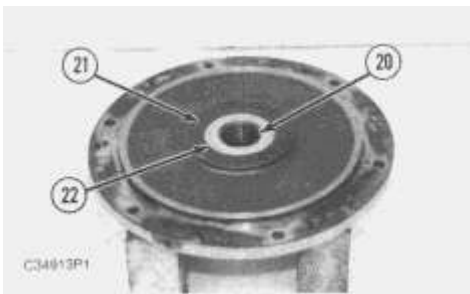

19. Position the stub shaft with the inner side up. Remove the screws and retainer (21). Remove seal (22) and bearing (20).

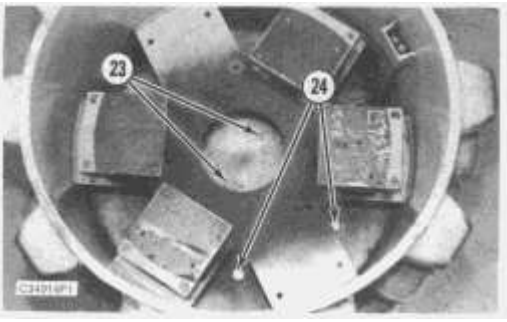

20. Using tooling (A) and a hoist, position the drum horizontally. Block the drum to keep it from moving. Remove cap plugs (23) from the rear of the eccentric weight housing.

21. Install two bolts, (2-7/16 N.C. × 3 in.), into the cap plug holes. Tighten the bolts down evenly until the bearing is pushed out. Remove the bearing.

22. Support the eccentric weight housing with a lifting device such as the forks of a lift truck. Remove six bolts (24) and separate the housing from the drum. The weight of the eccentric weight housing is **100 kg (75 lb)**

NOTE: The following steps are for the assembly of the drum.

NOTE: Make sure all parts are clean. Inspect for wear or damage and replace as required. If the bearings are replaced, replace the corresponding race.

NOTE: When heating parts for assembly, keep flammable materials away from the heat source. Use appropriate safety equipment to avoid personal injury. Hot parts can cause severe burns.

23. Using a support such as a lift truck, position the eccentric weight housing in the drum and install it with six bolts (24).

24. Using a torch, heat the bearing holder in the eccentric weight housing to **83°C (180°F)**.

25. Install bearing (14) into the heated eccentric weight housing. If necessary, use a brass drift to carefully tap the bearing against the outer bearing race to seat the bearing.

26. Fill the indentation side of seal (13) with clean grease and install the seal with the greased side towards the bearing. Crimp the edges of the seal with a screwdriver to hold it in position.

27. Install retainer (12) with the bolts. Use a center punch to punch the bolt heads twice (where indicated) to add to the bolt retention.

28. Using a hoist, install the eccentric weight into into the drum.

29. Heat the stub shaft to **83°C (180°F)**.

30. Install bearing (20) into the stub shaft. A brass drift may be used against the outer bearing race the tap the bearing into place.

31. Fill the indentation side of seal (22) with clean grease and install the seal with the greased side towards the bearing.

32. Using new bolts, install retainer (21) and torque the bolts to **40 N·m (30 lb ft)**. Use a center punch to punch the bolt heads twice (where indicated) to add to the bolt retention.

33. Heat bearing (19) to **83°C (180°F)** and install it onto the stub shaft (using a brass drift to seat the bearing if necessary).

34. Install ring wiper (18) into the hub. Thoroughly grease the hub slots with clean grease and install the hub onto the stub shaft.

35. Install the outer bearing onto the stub shaft. Install bearing spacer (16).

36. Install retainer (17) with the bolts. Tighten the bolts to a torque of **48 N·m (35 lb ft)**.

37. Install flange hub (15) and the key onto the shaft.

38. Using a hoist, install the stub shaft assembly into the drum making sure the bolt holes are properly aligned.

39. Install bolts (10)

40. Install hose guard (8) with the two bolts. Connect hose assembly (9).

NOTE: Pack the coupling assembly with clean grease before assembling.

41. Install hytel element (7), three bolts (6). Loosely install puller bolt (3).

42. Install insert assembly (4) and snap ring (5). Tighten puller bolt (3) to **approximately 107 N·m (78 lb ft)** to seat the coupling assembly on the weight shaft.

43. Install motor mounting plate (2) with six bolts (1).

44. Using tooling (A) and a hoist, position the drum horizontally.

End By:

a. remove vibratory arm

b. remove vibratory motor

c. remove drum drive motor

d. remove drum

Product: VIBRATORY COMPACTOR

Model: CP-323 VIBRATORY COMPACTOR 6JD

Configuration: CP-323 VIBRATORY COMPACTOR 6JD00001-00065 (MACHINE) POWERED BY 4219D ENGINE

Disassembly and Assembly CP/CS-323 VIBRATORY COMPACTORS VEHICLE SYSTEMS

Media Number -KENR1607-00

Publication Date -01/06/1990

Date Updated -10/10/2001

Vibratory Arm

SMCS - 6606-010

Remove & Install Vibratory Arm

Start By;

a. remove drum

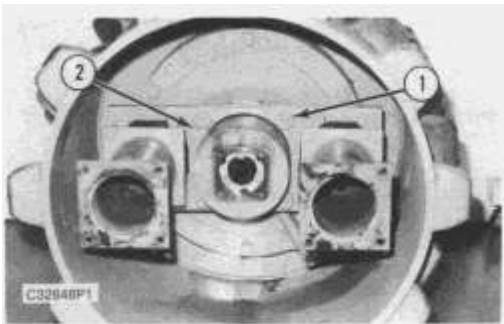

For illustration purposes only.

1. Attach a hoist to vibratory arm (2).
2. Remove four nuts (1) and vibratory arm (2). The weight of the vibratory arm is **41 kg (90 lb)**.

NOTE: The following steps are for the installation of the vibratory arm.

3. Using a hoist, install vibratory arm (2).
4. Install four nuts (2). Tighten to a torque of **100 ± 13 N·m (75 ± 10 lb ft)**.

End By;

a. install drum

Product: VIBRATORY COMPACTOR

Model: CP-323 VIBRATORY COMPACTOR 6JD

Configuration: CP-323 VIBRATORY COMPACTOR 6JD00001-00065 (MACHINE) POWERED BY 4219D ENGINE

Disassembly and Assembly CP/CS-323 VIBRATORY COMPACTORS VEHICLE SYSTEMS

Media Number -KENR1607-00

Publication Date -01/06/1990

Date Updated -10/10/2001

Drum Motor

SMCS - 5058-010; 5058-015; 5058-016

Remove & Install Drum Motor

| Tools Needed | | A |
|--------------|--------------|---|
| 6V2157 | Link Bracket | 2 |

Start By:

a. remove drum

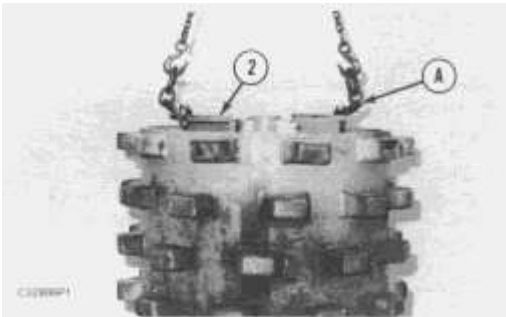
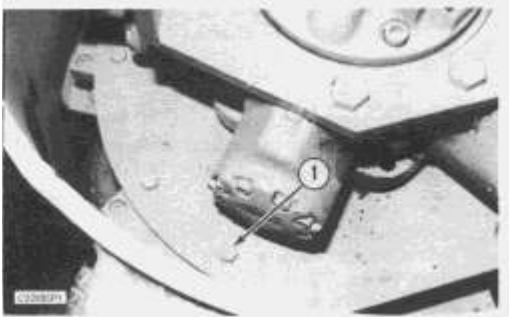

1. Position the drum vertically.
2. Remove eight bolts (1).

3. Install tooling (A) on motor mount (2). Attach a hoist and lift the drum drive motor out of the drum. The weight of the motor is **1100 kg (500 lb)**.

NOTE: Install in reverse order.

End By:

- a. install drum

Disassemble Drum Motor

Start By;

- a. remove drum
- b. remove drum drive motor

| Tools Needed | | A | B | C | D | E | F |
|--------------|------------------------|---|---|---|---|---|---|
| 5F7347 | Head | 1 | | | | | |
| 7F1858 | Screw | 1 | | | | | |
| 7F1859 | Nut | 1 | | | | | |
| 5F7353 | Washer | 1 | | | | | |
| | Bolt (1/2-13x12) | 3 | | | | | |
| 6V2156 | Link Bracket | | 1 | | | | |
| 8H0700 | Puller | | | 1 | | | |
| 9S9153 | Legs | | | 3 | | | |
| 1P0532 | Driver | | | | 1 | | 1 |
| 1P5245 | Plate | | | | 1 | | |
| 5P4758 | Pliers | | | | | 1 | |
| 1P5245 | Plate (3 5/6 in. dia.) | | | | | | 1 |

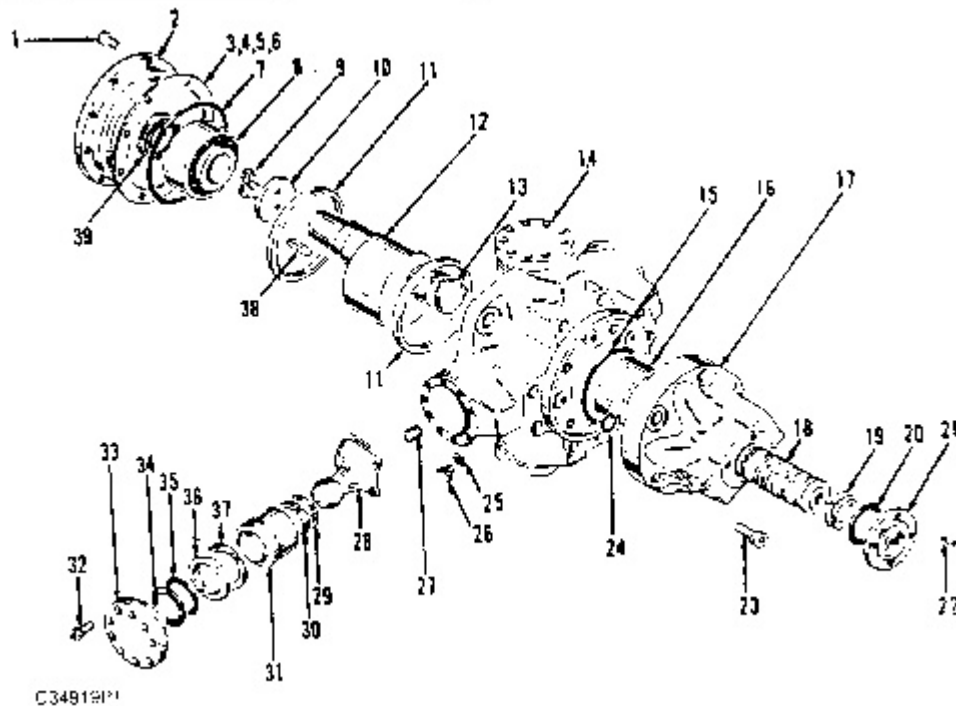

C34918P1



1. Set the motor on blocks as shown. Remove the motor mount from the motor.

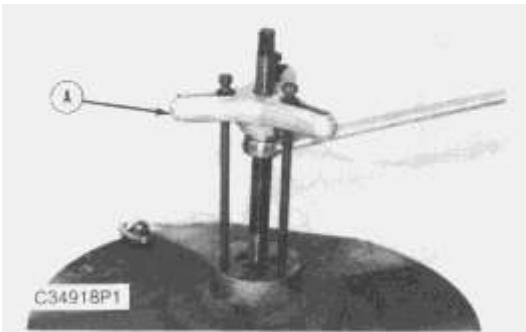

2. Using tooling (B) and a hoist, turn the motor over on the blocks. Using tooling (A), remove the drive and seal weldment.

3. Set the motor on end cap (20) with crankshaft (6) up.

NOTE: Inspect the keyway for burrs or sharp edges. Remove burrs or sharp edges to prevent damage to the shaft seal when the front cover is removed.

4. Grind off the lock and remove three bolts (9), end plate (10) and key (38).

NOTE: If jack screw hole threads are are stripped, the motor can not be disassembled.

5. Run a bottoming tap into the jack screw holes in front cover (2) and use clean shop air to clean the holes out.
6. Remove front cover cap screws (1).
7. Turn two socket cap screws into the jack holes in the front cover until they bottom out. Alternately turn the cap screws in about one half turn at a time so the front cover comes up evenly.
8. Carefully remove front cover (2) so seal (7) and the shims [called out as (3), (4), (5) and (6)] are not damaged.
9. Inspect O-ring seal (7). Replace if required.
10. Using tooling (F) and a press, remove shaft seal (39).
11. Remove top rod retaining ring (30) and lift connecting rods (28) from the bottom retaining ring and push the connecting rods up into the cylinder bores.
12. Remove crankshaft assembly (9) from the motor. The weight of the crankshaft is **23 kg (50 lb)**.
13. Remove bottom retaining rings (30).

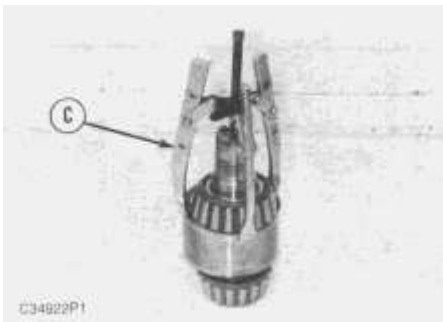

NOTE: Remove the bearings only if necessary. If the bearings are replaced, the bearing cups must also be replaced.

14. If the bearings are not damaged, do not perform Step 15, proceed to Step 16. If necessary, remove bearings (8) and (16) with tooling (C).

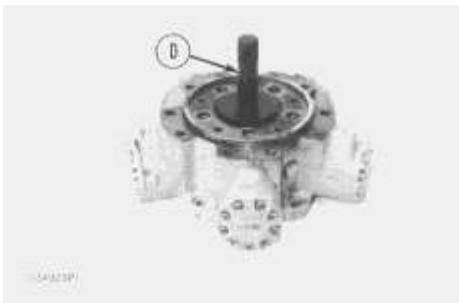

15. Using tooling (D), remove the rear bearing cup from the motor case. Remove the front bearing cup from the front cover.
16. Remove each of the piston-connecting rod assemblies by pulling them back into the crankcase and lifting them out.

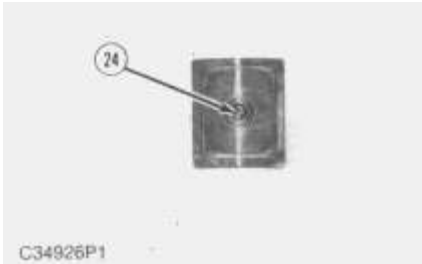
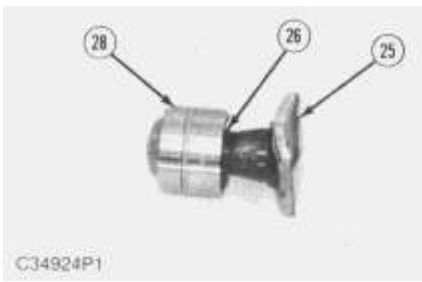

NOTE: Mark the piston-connecting rod assemblies as to their original location for assembly purposes. Keep the piston with the original connecting rod.

17. Remove snap ring (29) with tool (E) and separate piston (31) from connecting rod (28). Using a screwdriver exactly fitting the slot in the restrictor screw, remove restrictor screw (26) from the connecting rod. Repeat for each of the piston-connecting rod assemblies.

18. Remove Oldham's coupling (13) from the end of valve spool (18) by wedging a round file in the end of the valve spool, lifting the spool until it can be grasped by hand and lifted out. If the valve spool can not be removed in this manner, end cap (21) will need to be removed and the spool will have to be tapped out.

NOTE: Normally further disassembly is not required unless the cylinder heads are leaking or the valve housing bore is scored. If the valve housing bore is scored, the motor case must be replaced. For cylinder head disassembly, perform Steps 19 & 20.

19. If the cylinder heads are leaking, remove bolts (32) and cylinder head (33).

20. Remove back-up ring (34) and O-ring seal (35). Inspect for wear or damage and replace as required.

Assemble Drum Motor

| Tools Needed | | A | B |
|--------------|--------------|---|---|
| 6V2156 | Link Bracket | 1 | |
| 5P4758 | Pliers | | 1 |

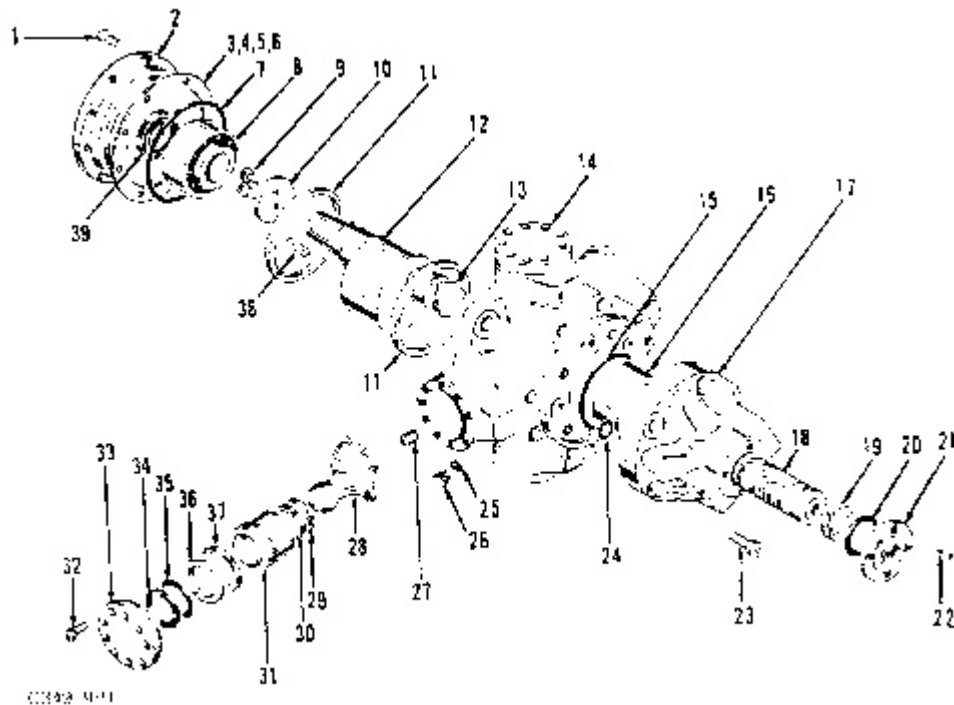

NOTE: Check all seals for wear or damage. Replace as required.

1. If bearings (7) and (16) were removed, install new bearings using a press.
2. If the cylinder heads were not removed, proceed to Step 7.
3. Place the motor on wooden blocks.
4. Remove restrictor screw (27). If there is a filter, remove and discard the filter. Filters are no longer necessary.
5. Install restrictor screw (27) with Loctite.
6. Install O-ring seal (35), backup ring (34) and cylinder head (33) with bolts (32). Tighten the bolts to a torque of **74 N·m (55 lb ft)**.
7. Install valve rings (19) on valve spool (18) with the ring gaps 180° apart. Install valve spool (18) into the bore.
8. Install O-ring seal (20). Install end cap (21) with bolts (22).
9. Both the end of valve spool (18) and crankshaft (12) are stamped with the letters TDC and an arrow pointing up. Mark the case at the spot where the arrow on the valve spool points up.
10. Attach connecting rods (28) to pistons (31) with snap rings (29) using tool (B).
11. Install the piston assemblies into the cylinder bores. The piston assemblies should slip in easily without using force.
12. Drop in bottom retaining rings (30) and lift the two connecting rods nearest the mark on the crankcase over the retaining rings and push the pistons into the bores.
13. Center coupling (13) in the slot in valve spool (18).

Thank you so much for reading.
Please click the “Buy Now!”
button below to download the
complete manual.



After you pay.

You can download the most
perfect and complete manual in
the world immediately.

Our support email:

ebooklibonline@outlook.com