

Product: VIBRATORY COMPACTOR

Model: CP-553 VIBRATORY COMPACTOR 7BD

Configuration: CS-551, CS-553, CP-553 VIBRATORY COMPACTOR 7BD00001-UP (MACHINE) POWERED BY 3208 ENGINE

Disassembly and Assembly

CP-553 & CS-553 VIBRATORY COMPACTORS VEHICLE SYSTEMS

Media Number -KENR1566-01

Publication Date -11/12/1996

Date Updated -10/10/2001

Axle And Differential

SMCS - 3265-016; 3265-015; 3278-010; 3278-015; 3278-016; 4050-015; 4050-016; 4054-015; 4054-016

Remove And Install Axle And Differential

Start By:

- a. remove rear wheel assemblies
- b. remove axle propel motor

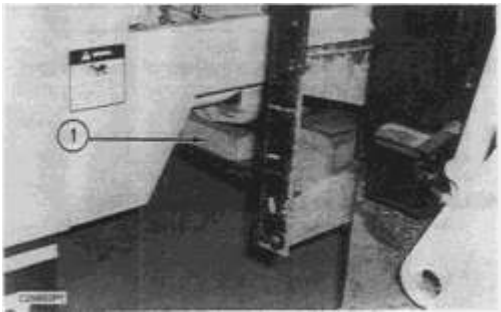

NOTE: The planetary carrier assemblies do not need to be removed.

1. Using a lift truck, install block (1) between fork and differential.

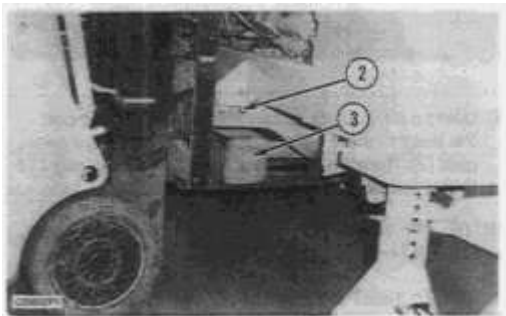

2. Install blocking (3) at both sides. Remove eight nuts (2) and lower the axle until there is clearance to remove the axle from under the machine. The weight of the axle is 580 kg (1300 lb).

NOTE: To install rear axle, reverse the removal steps.

End By:

- a. install rear wheel assemblies
- b. install axle propel motor

Disassemble Torque Hub (Soma Axle And Differential)

NOTE: Clean the outside of the torque hub thoroughly before starting disassembly. Perform disassembly and assembly in a clean work area to prevent contaminants from entering the torque hub.

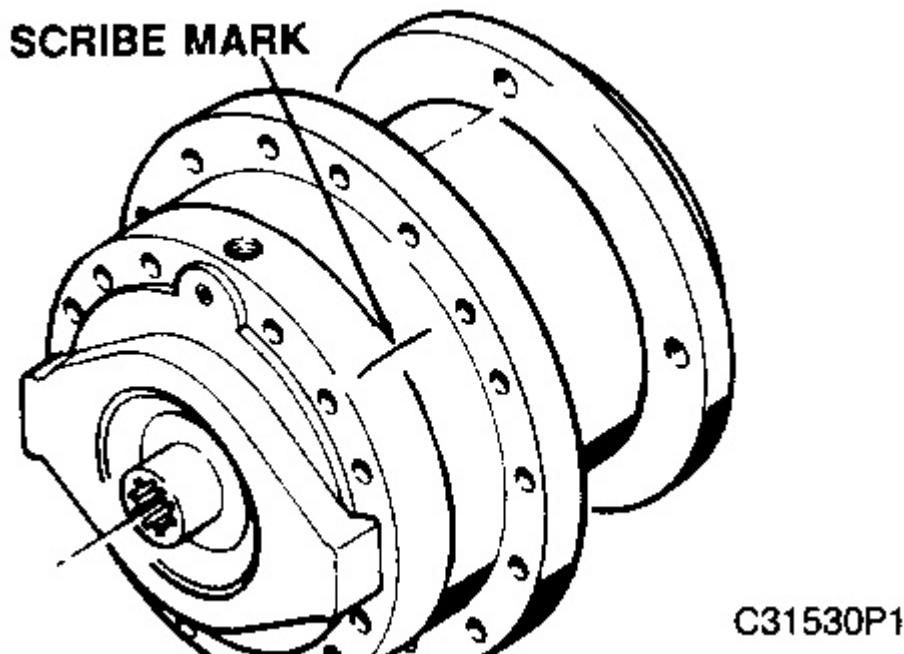

-
1. Make matching scribe marks on the cover, ring gear, and hub. This will help ensure that these parts are reassembled in their original positions.

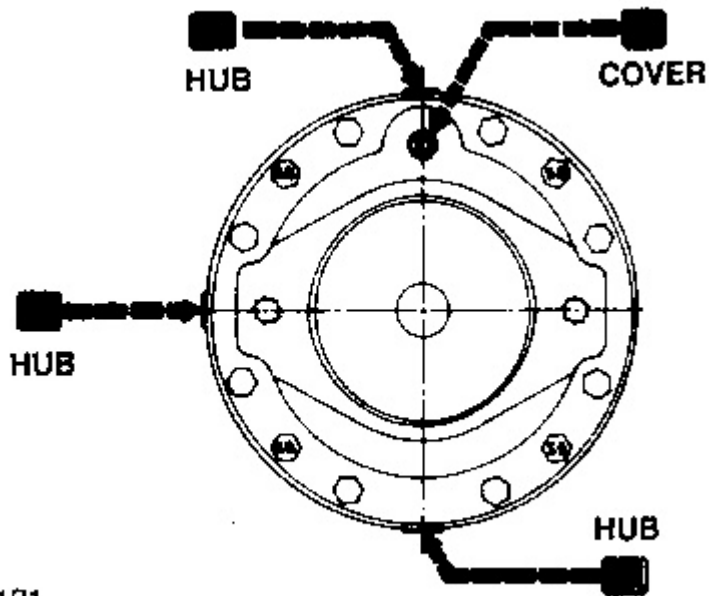

2. Remove one or more plugs to drain lubricant from the torque hub. Replace the plug after lubricant has drained.

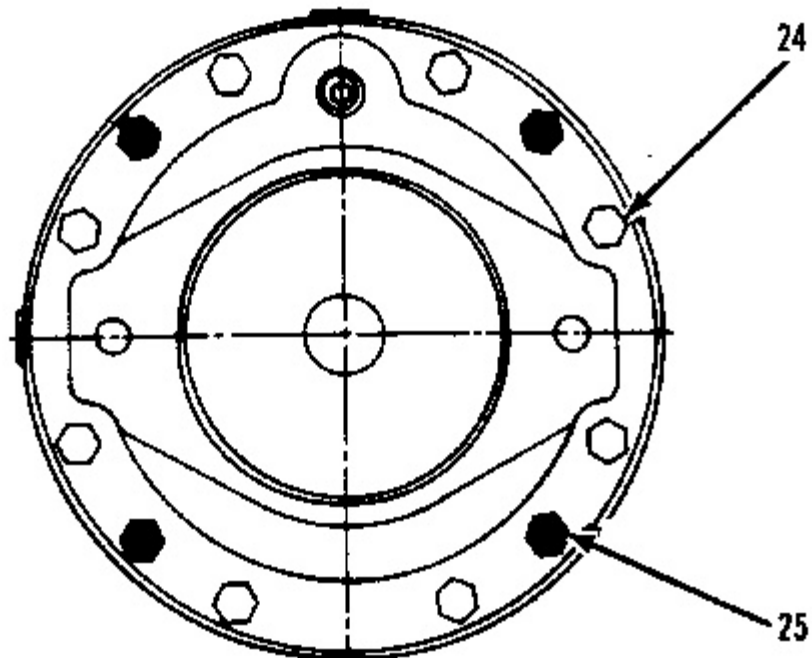

NOTE: The cover is secured to the torque hub with eight standard bolts (24) and four shoulder bolts (25). These bolts are positioned in the cover as shown above.

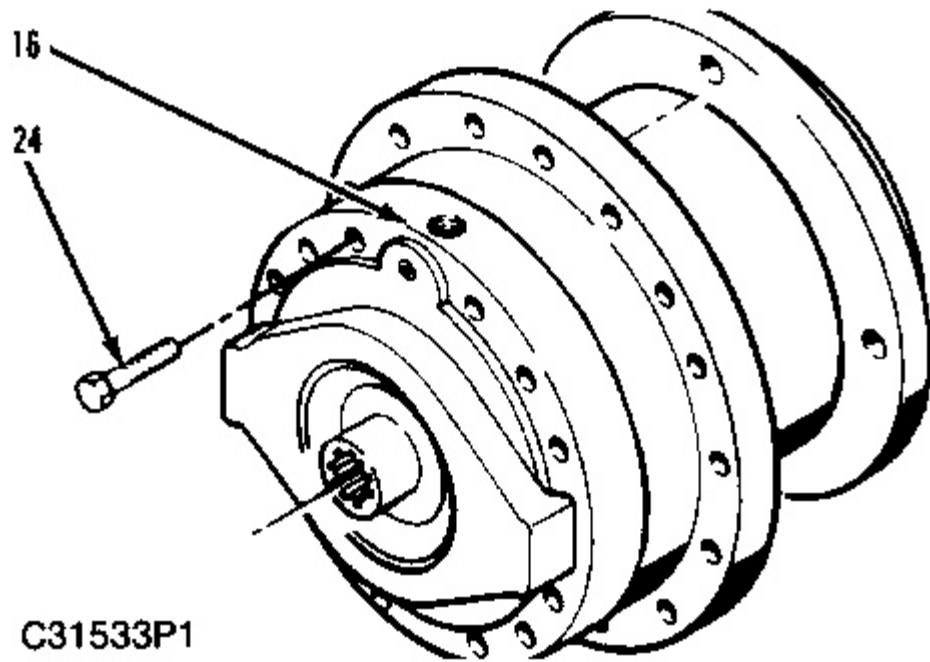

3. Remove eight standard bolts (24) from cover (16).

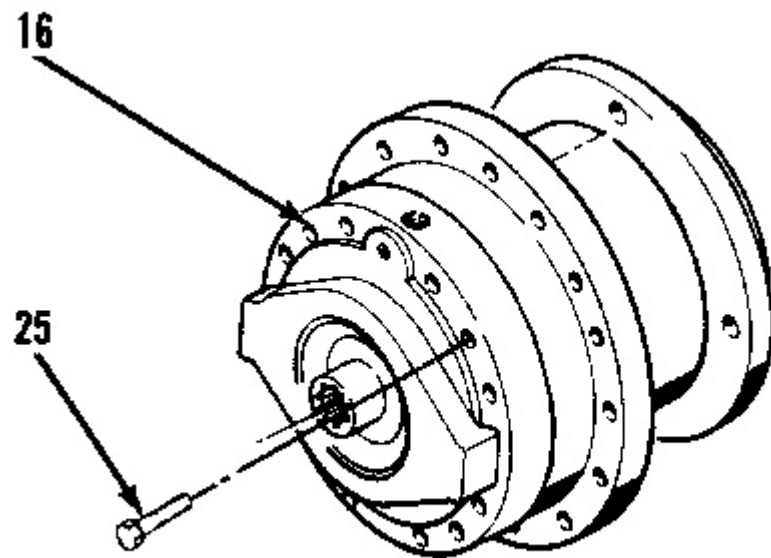

4. Remove four shoulder bolts (25) from cover (16).

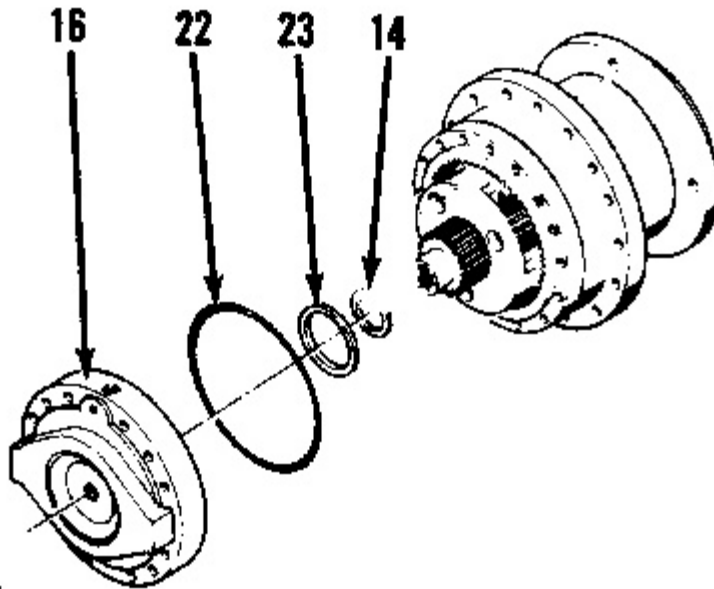

C31535P1

5. Remove cover (16), one O-ring (22), and two thrust washers (23) and (14) off the torque hub. Discard O-ring (22). This must be replaced with a new part during assembly.

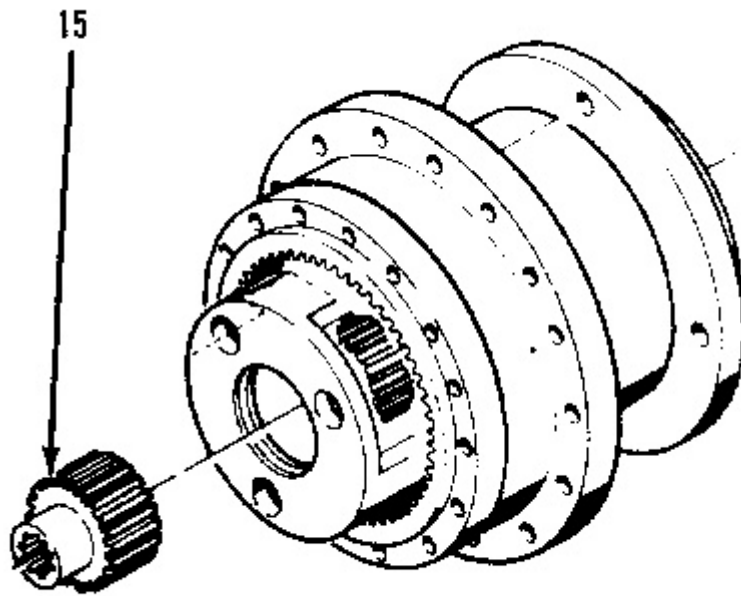

C31536P1

6. Remove input gear (15).

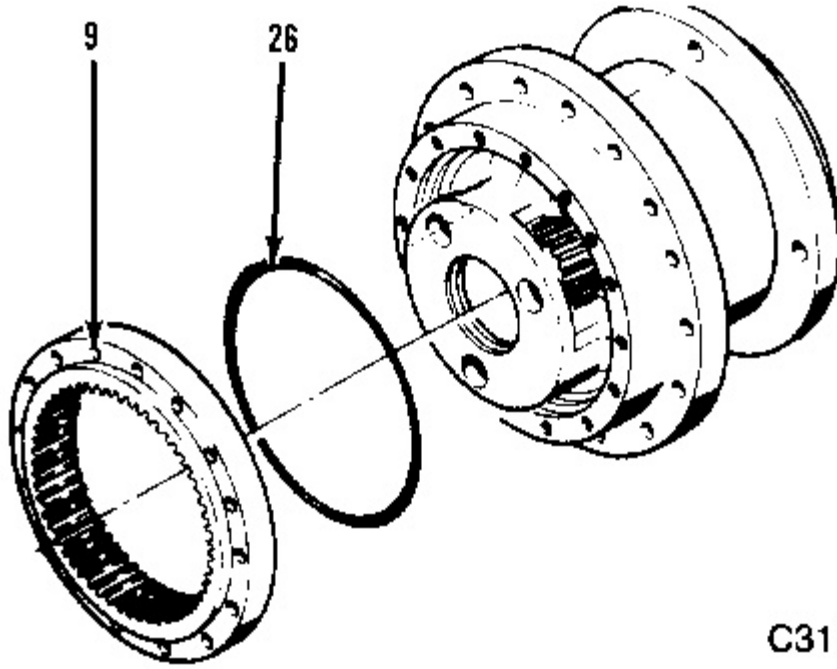

C31537P1

7. Remove ring gear (9) and remaining O-ring (26). Discard O-ring (23). This must be replaced with a new part during assembly.

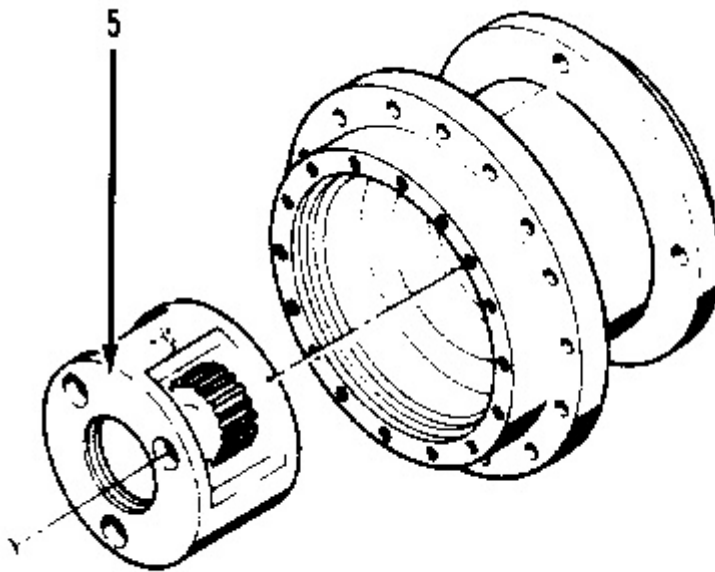

C31538P1

8. Remove carrier (5).

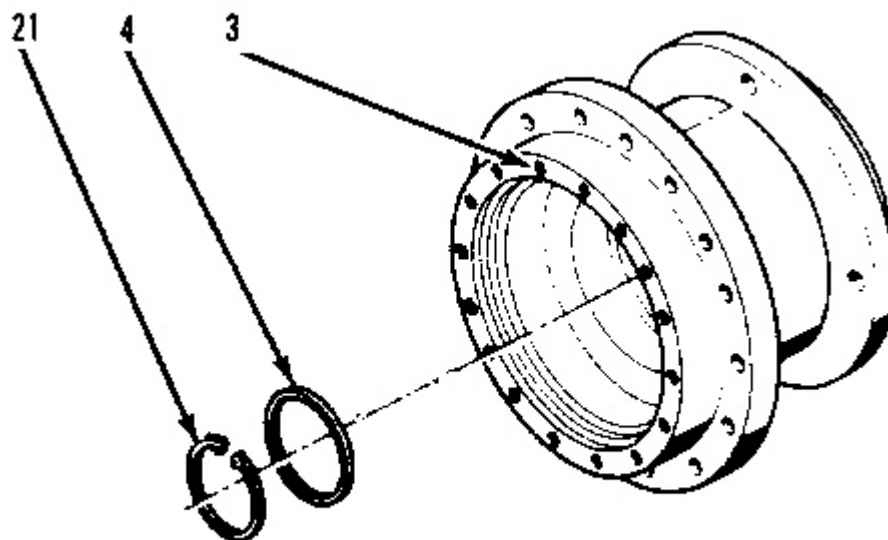

C31539P1

9. Place a bearing cone pressing tool on top of retaining ring (21) inside the hub.

10. Press the tool with a hydraulic ram or by striking with a soft face hammer. Pressure should be applied until hub (3) rotates with difficulty. This step is necessary to remove the preload against retaining ring (21).

 **WARNING**

Wear safety glasses to prevent injury from possible flying parts during the following step.

11. Use retaining ring pliers to remove retaining ring (21). Remove spacer (4). Discard retaining ring (21). This must be replaced with a new part during assembly.

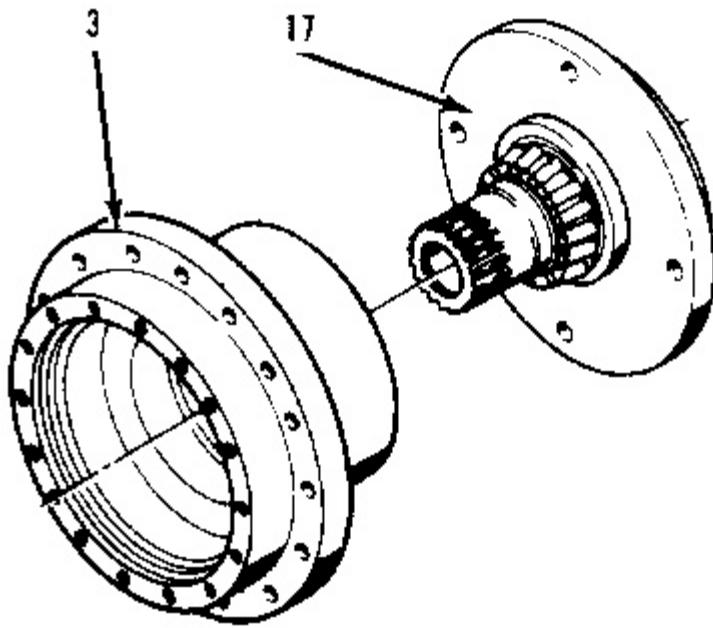

C31540P1

12. Press spindle or output shaft (17) out of hub (3).

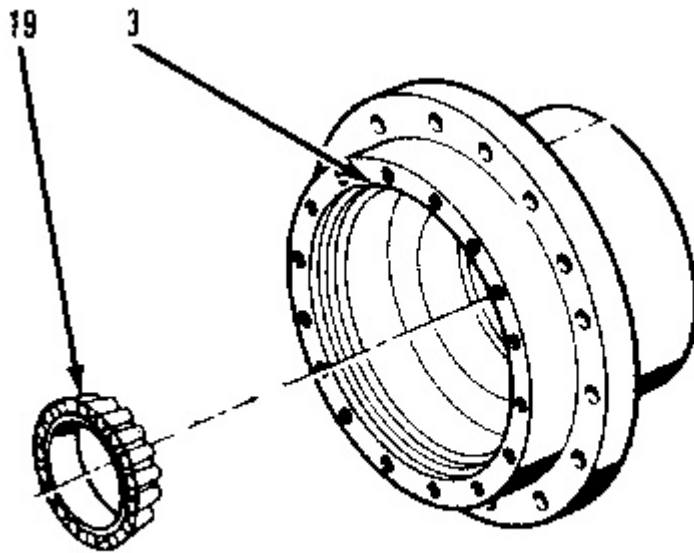

C31541P1

13. Pull outer bearing cone (19) out of hub (3).

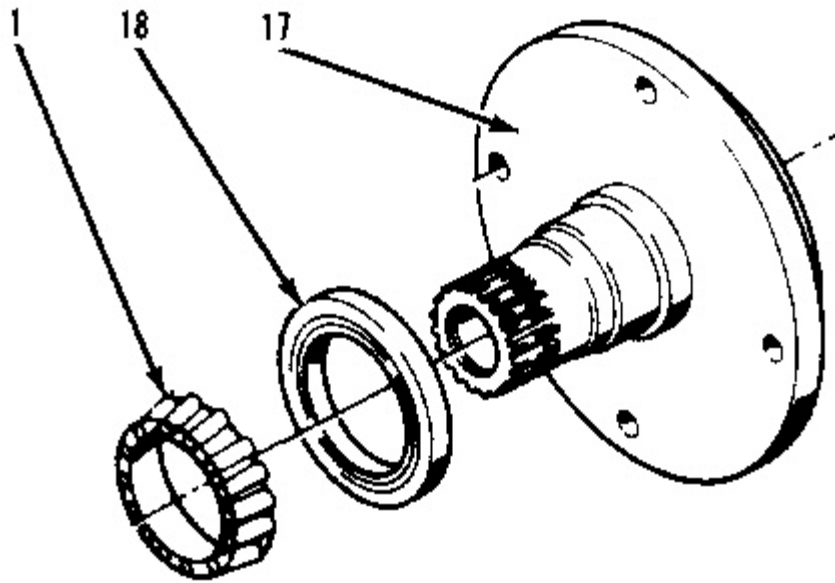

C31542P1

14. Pull inner bearing cone (1) and seal (18) off spindle or output shaft (17). Discard seal (18). This must be replaced with a new part during assembly.

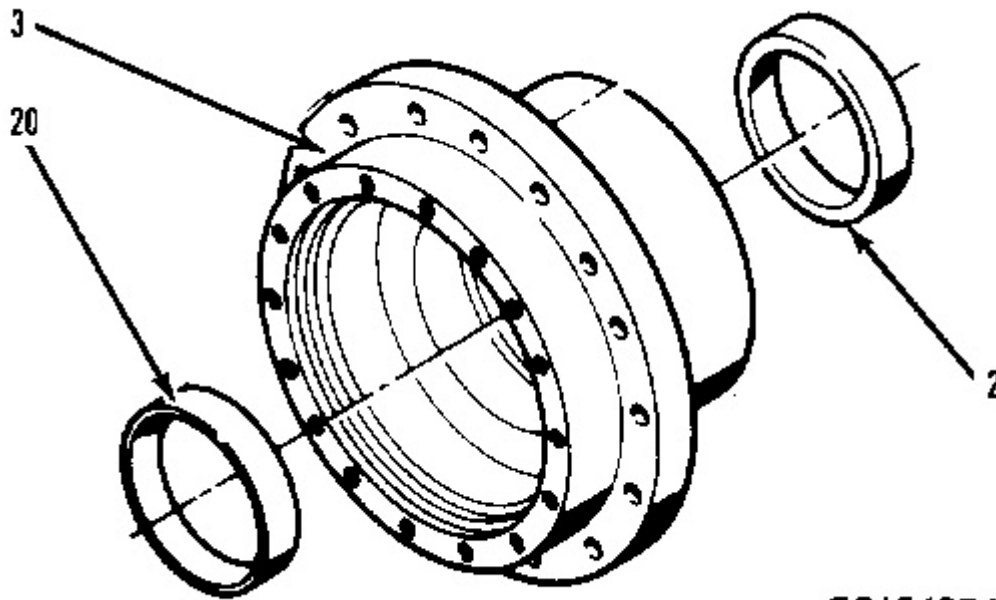

C31543P1

15. Press two bearing cups (2) and (20) out of hub (3).

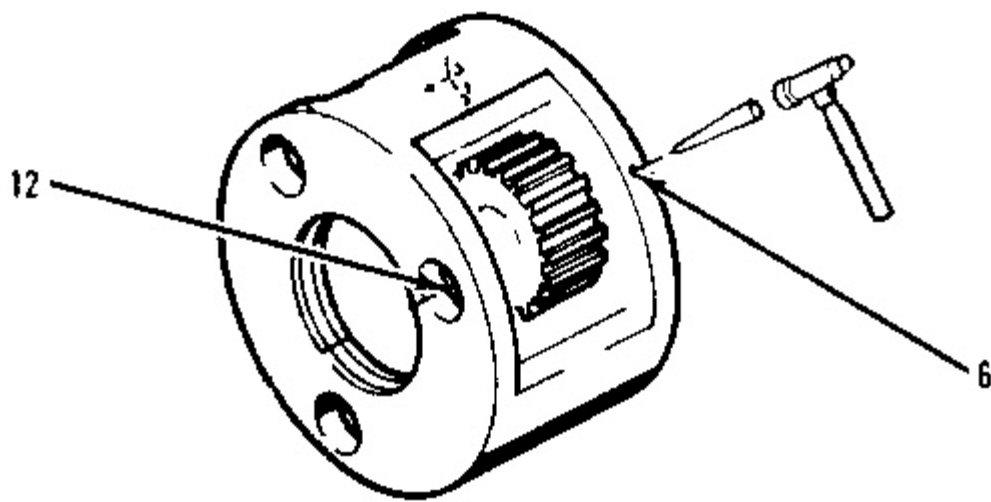

C31544P1

16. Drive roll pin (6) out of one of the planet shafts (12).

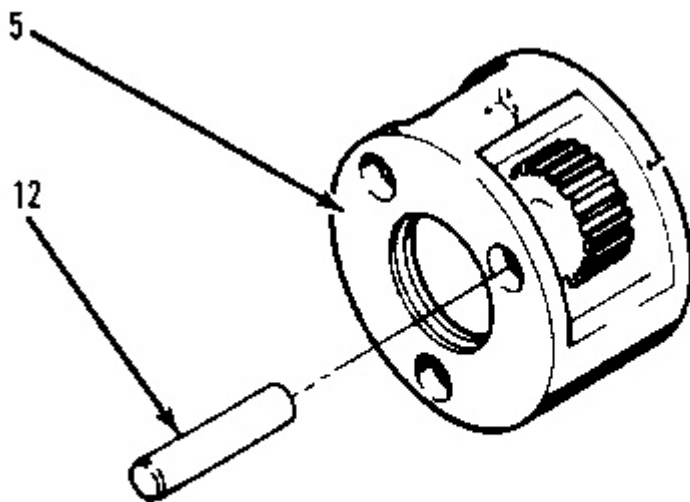

C31545P1

17. Remove planet shaft (12) from carrier (5).

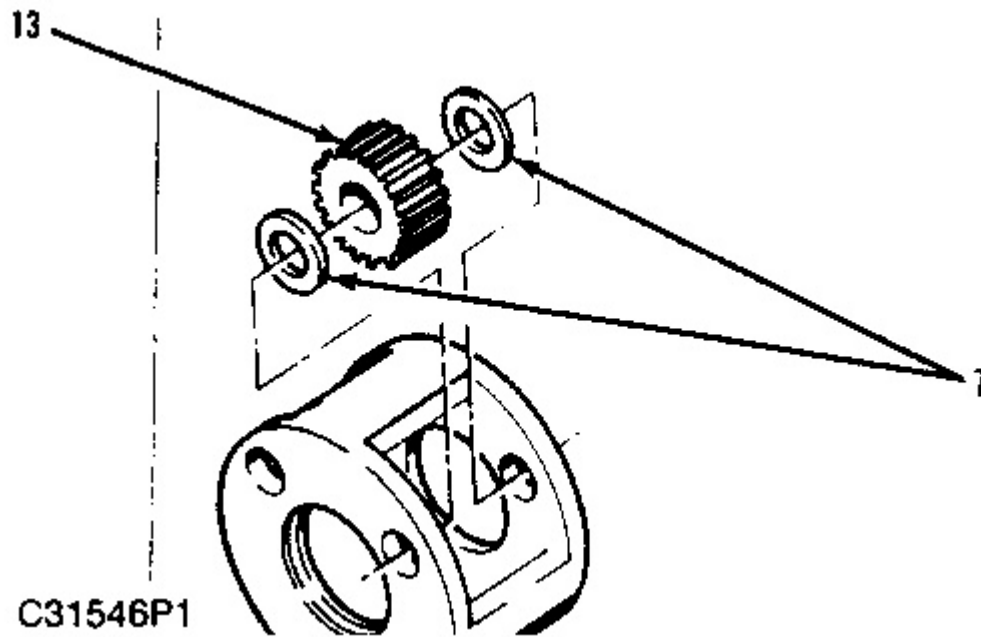

18. Remove planet gear (13) and two thrust washers (7) from the carrier.

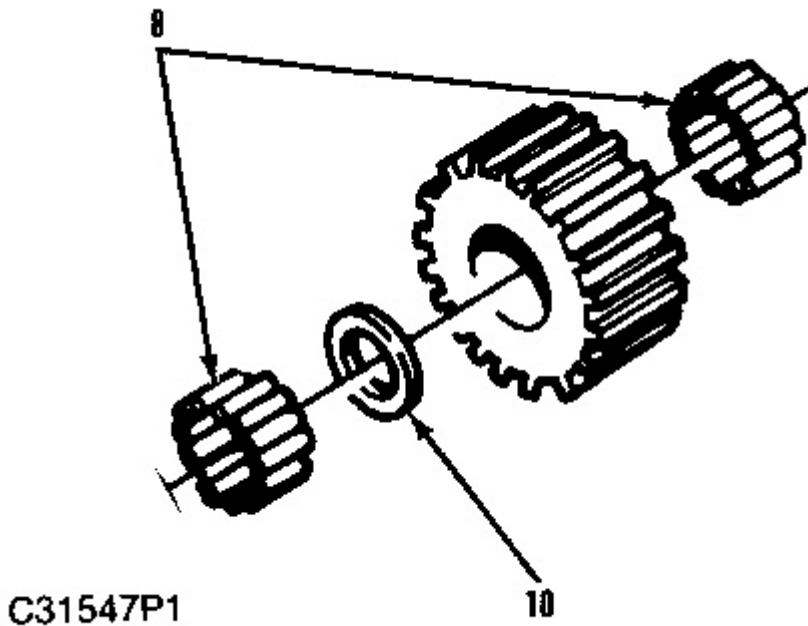

19. Remove two rows of needle rollers (8) and one spacer (10) from the bore of the planet gear.

20. Repeat Steps 16 through 19 for the remaining two planet gears.

21. Wash all parts in clean solvent. Dry parts thoroughly and inspect for damage or excessive wear. Replace parts as necessary before assembly.

Assemble Torque Hub

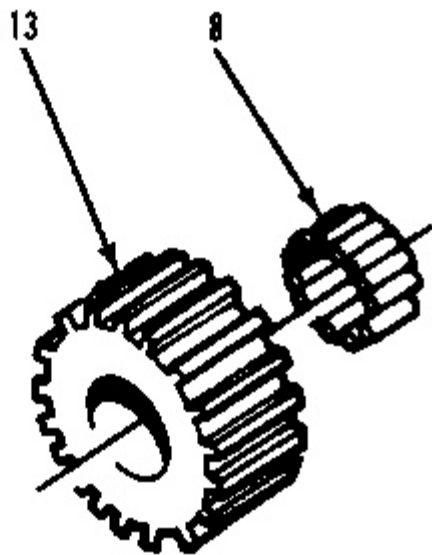

C31548P1

1. Apply a coat of grease inside the bore of one planet gear (13). This will hold needle rollers (8) in place during assembly.
2. Install the first row of 16 needle rollers (8) into the bore of the planet gear.

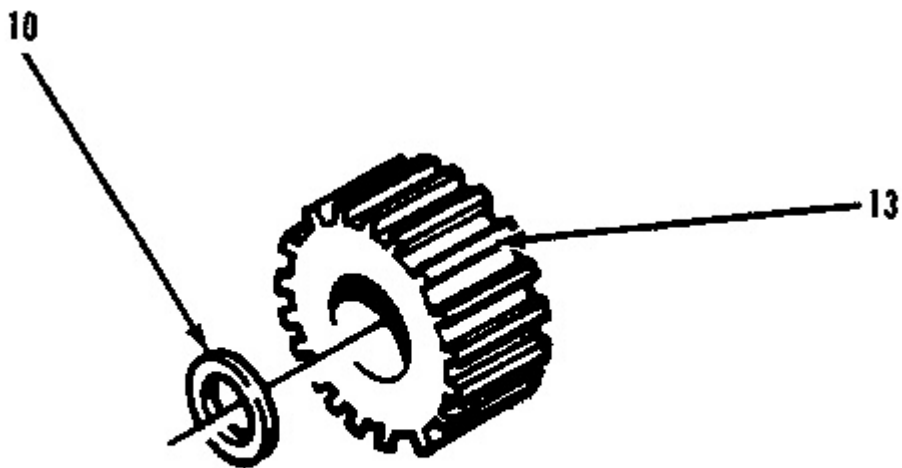

C31549P1

3. Set spacer (10) into the bore of planet gear (13) on top of the needle rollers.

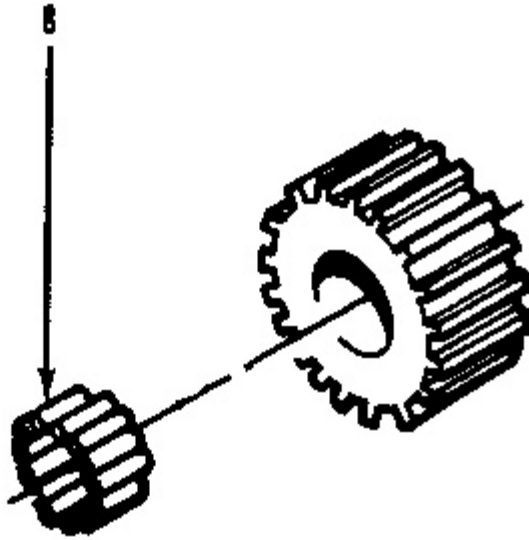

C31550P1

4. Install a second row of 16 needle rollers (8) into the bore of the planet gear.

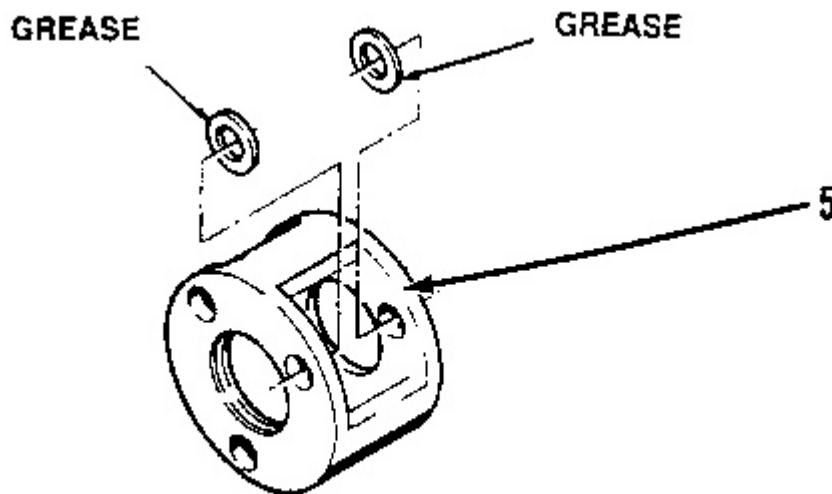

C31551P1

5. Apply grease to the tang side of the two thrust washers. Place the thrust washers against bosses in carrier (5). Washer tangs must fit into slots in carrier's outside diameter.

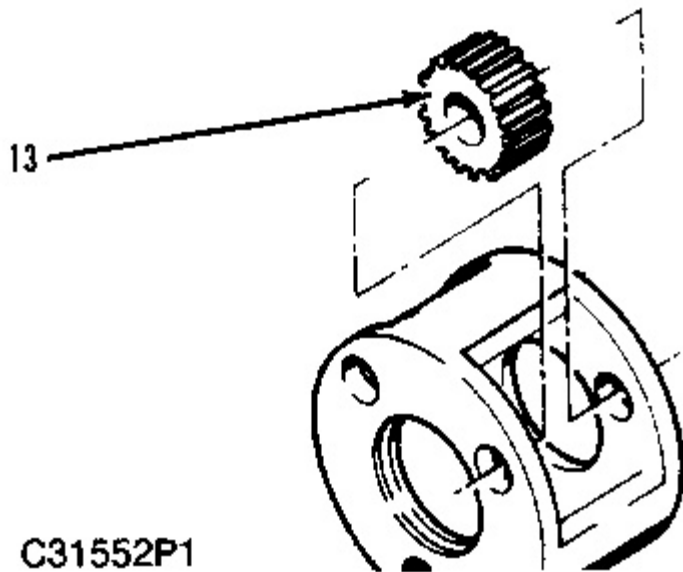

C31552P1

6. When the thrust washers are in place, slide planet gear (13) between them. Line up the planet gear bore with the hole in the carrier.

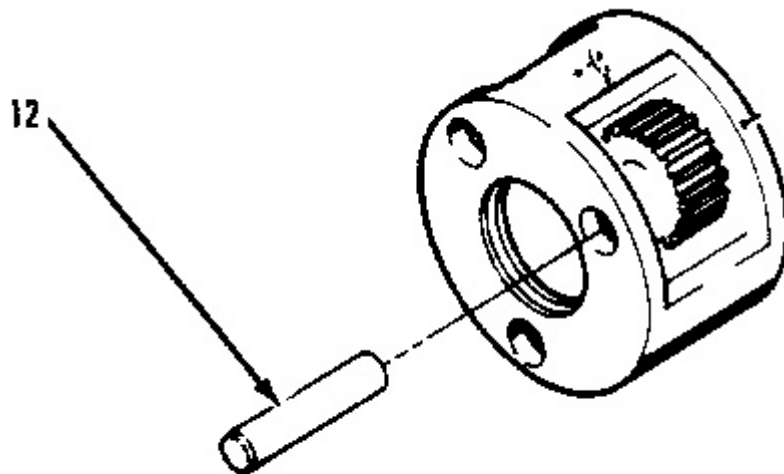

C31553P1

7. Install one planet shaft (12) through the carrier and planet gear. Line up the roll pin hole in the planet shaft with the carrier roll pin hole.

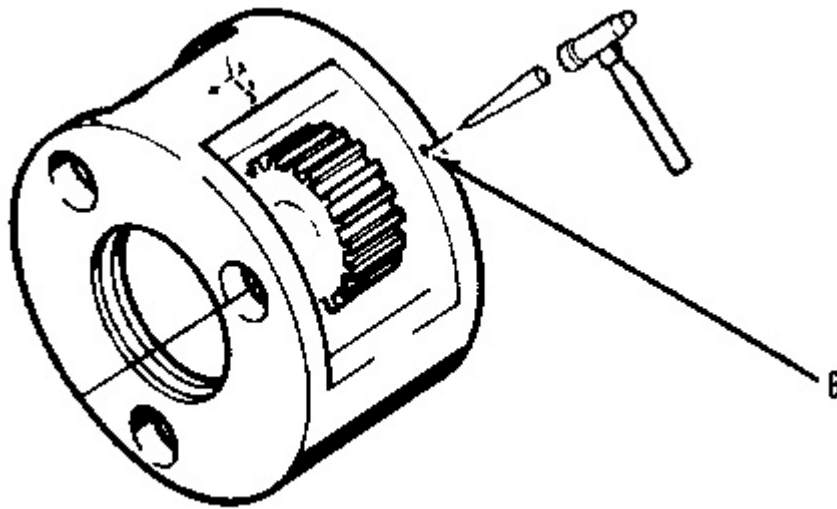

C31554P1

8. Drive roll pin (6) into the carrier hole, locking the planet shaft in place. Make sure the roll pin is driven at least flush with the carrier.
9. Repeat Steps 1 through 8 for the remaining two planet gears.

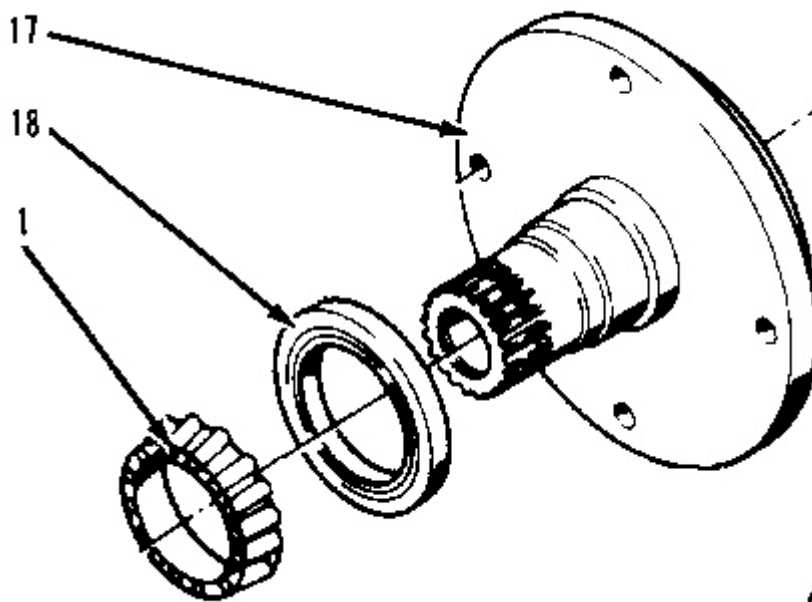

C31555P1

10. If the torque hub uses a spindle (17), as shown above, prepare for assembly as follows:
 - a. Apply a light film of oil to a new seal (18).
 - b. Press the seal onto the spindle shoulder so that the closed end of the seal faces the spindle drive plate. Make sure the seal is installed square with the spindle.
 - c. Press inner bearing cone (1) onto spindle (17).

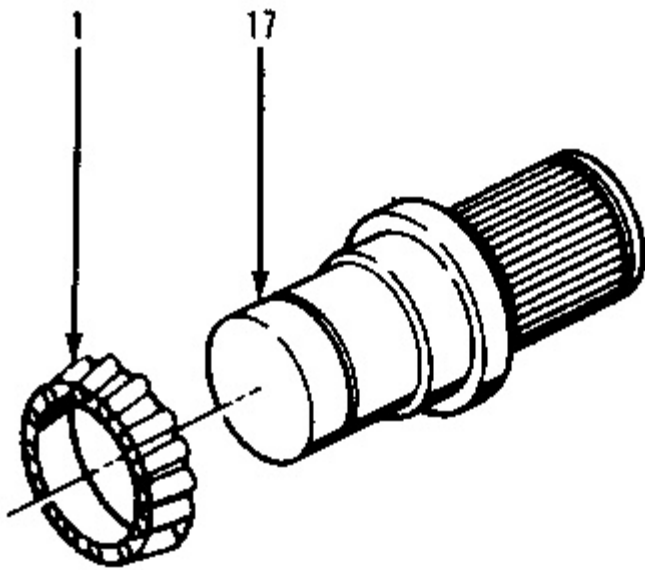

C31556P1

11. If the torque hub uses an output shaft (17), as shown above, press inner bearing cone (1) onto the output shaft. Seal (18) will be installed in a later step.

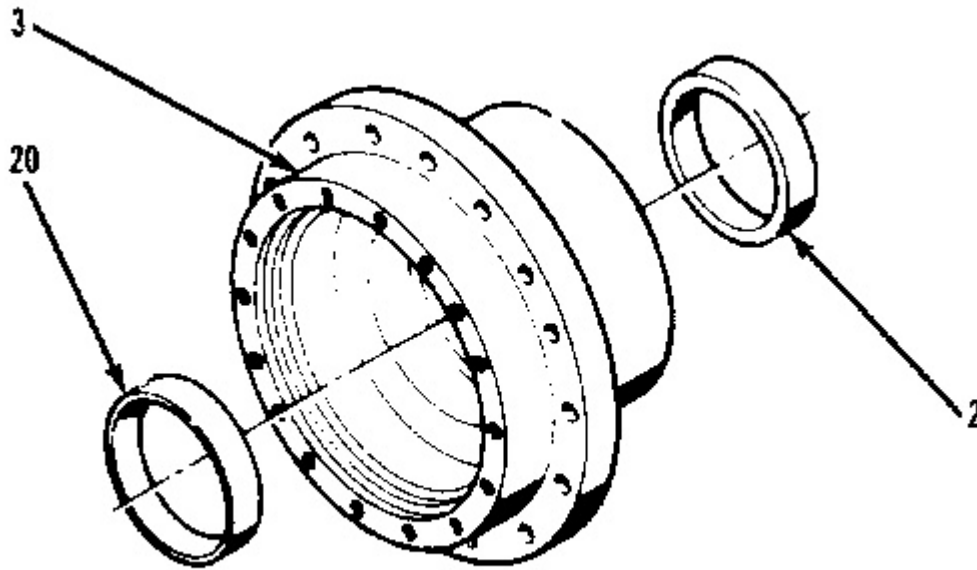

C31557P1

12. Press inner bearing cup (2) and outer bearing cup (20) in place inside hub (3).

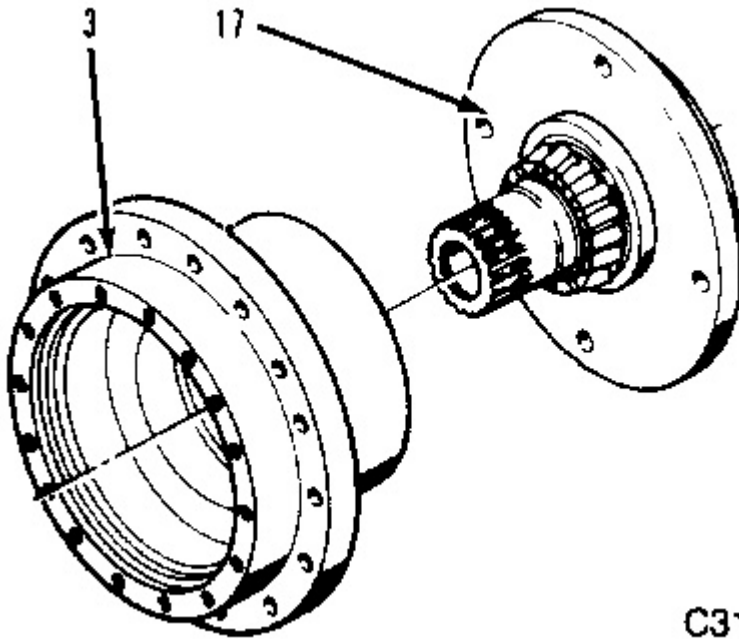

C31558P1

13. Carefully raise hub (3) and set in place on spindle or output shaft (17). Use care to prevent damaging the seal, if installed.

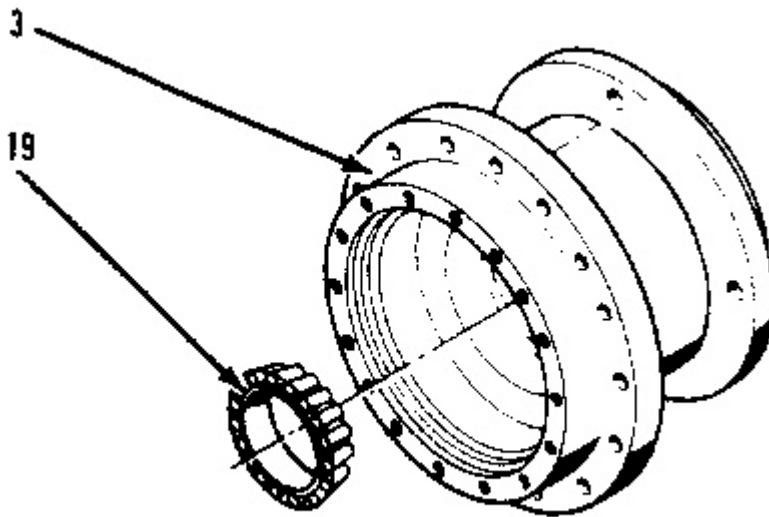

C31559P1

14. Press outer bearing cone (19) on the spindle or output shaft inside hub (3). Rotate the hub while pressing the bearing. Stop pressing when the hub starts to resist rolling.

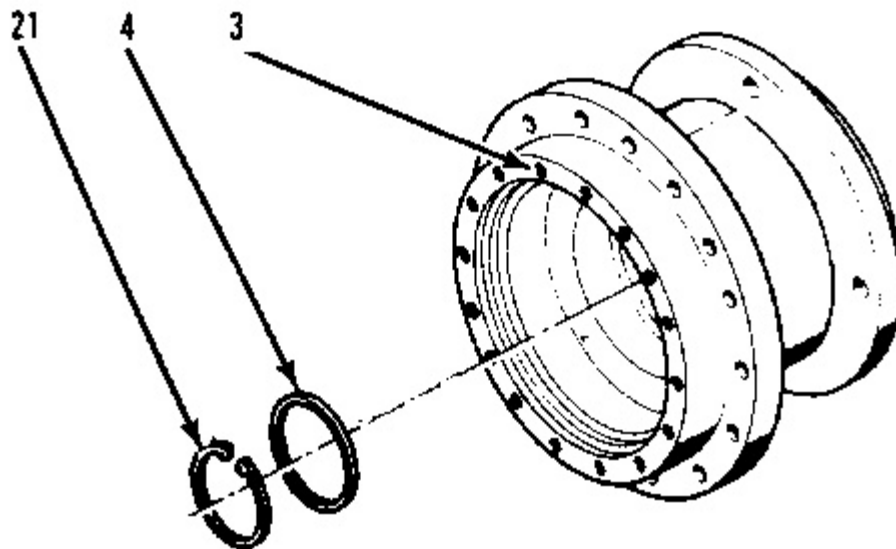

C31539P1

15. Install spacer (4) so that it rests on top of the outer bearing cone.



WARNING

Wear safety glasses to prevent injury from possible flying parts during the following step.

16. Use retaining ring pliers to install a new retaining ring (21) into the groove on the spindle or output shaft. Use a soft punch against the retaining ring to be sure it is seated.

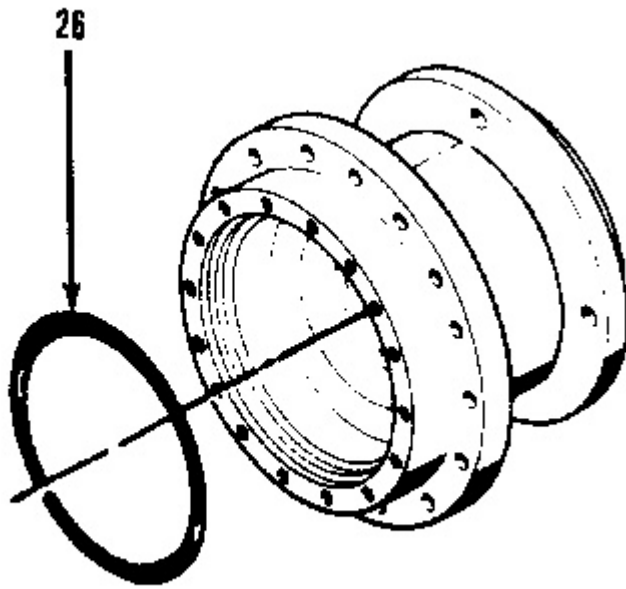

C31560P1

17. Apply a light coat of grease to one new O-ring (26). Install the O-ring into the counter-bore of the hub.

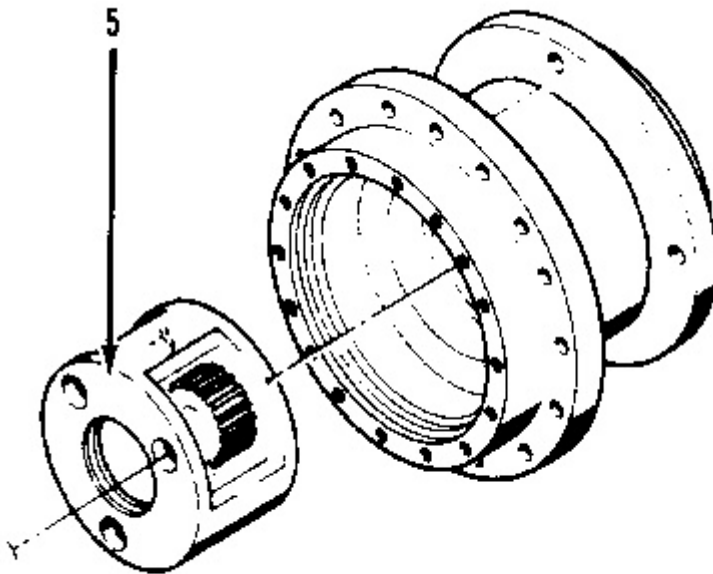

C31538P1

18. Install carrier (5) into the torque hub. Make sure the internal spline of the carrier engages the spline of the spindle or output shaft inside the hub.

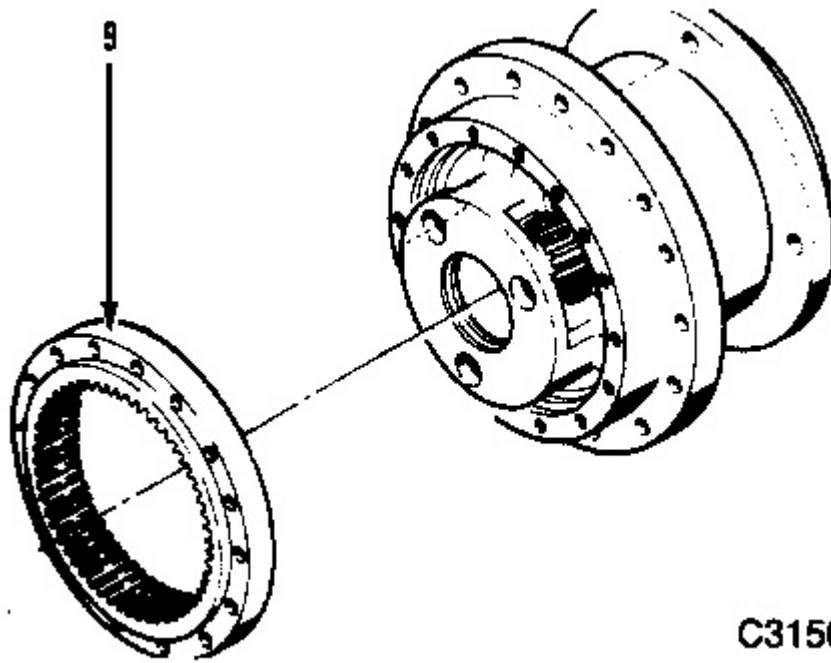

C31561P1

19. Slide ring gear (9), with the shoulder side toward the hub, into mesh with the planet gears. Be sure to align the scribe marks made during disassembly.

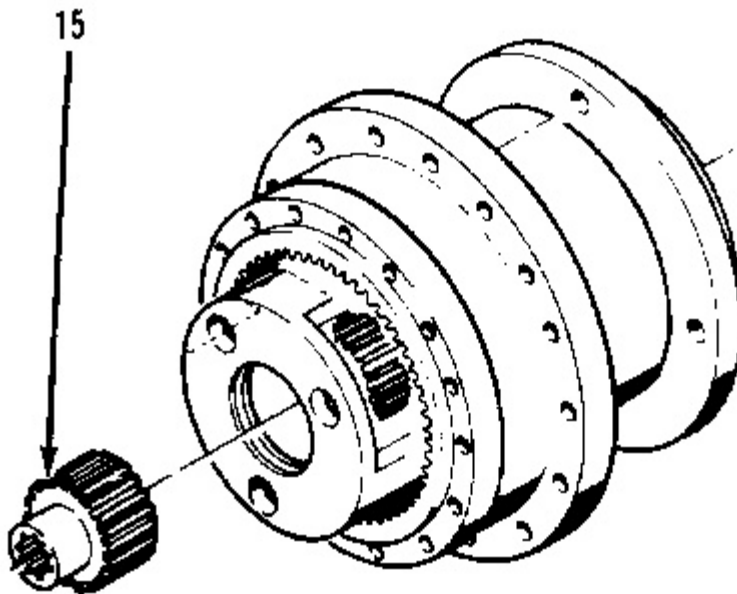

C31536P1

20. Slide input gear (15) into mesh with the planet gears inside the carrier until it rests against the shoulder.

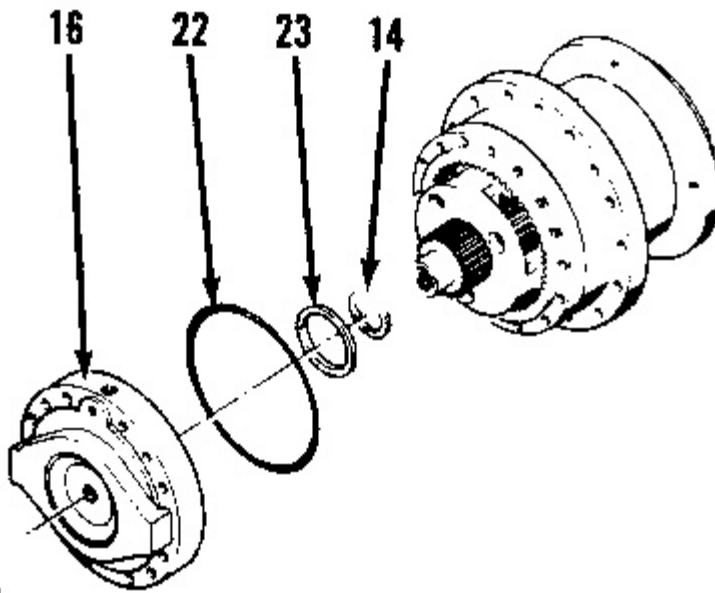

C31535P1

-
21. Place small thrust washer (23) over the input gear.
 22. Apply grease to one side of large thrust washer (14). Place the thrust washer on the counter-bore of the carrier with the greased side facing the torque hub cover.
 23. Apply a light coat of grease to the second new O-ring (22). Install the O-ring into the counter-bore of cover (16).
 24. Install cover (16) to the torque hub. Be sure to align the scribe marks made during disassembly.

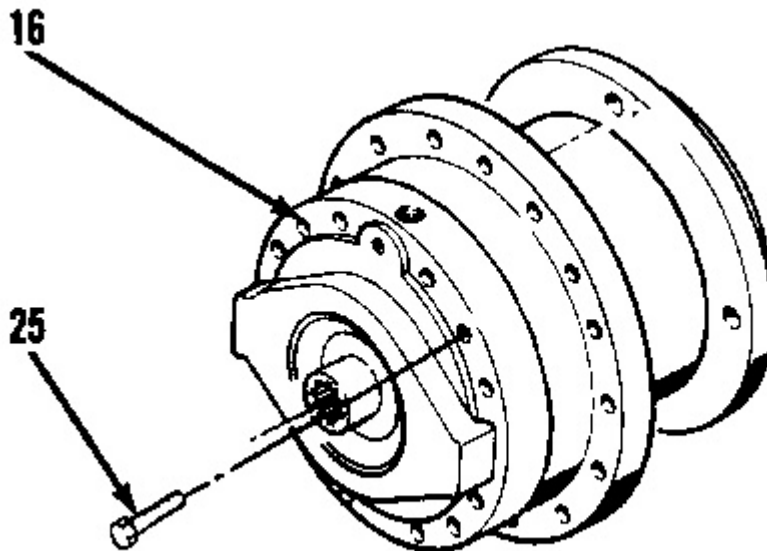

C31534P1

-
25. Install four shoulder bolts (25) into the torque hub cover as shown. Tighten the bolts to 31 to 36 N·m (23 to 27 lb ft).

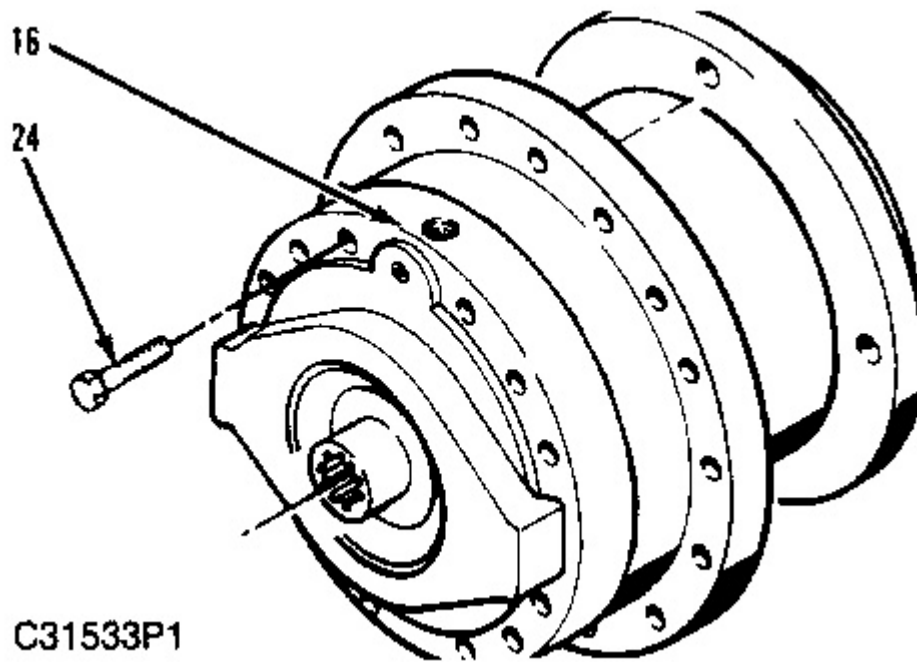

26. Install eight standard bolts (24) into the torque hub cover as shown. Tighten the bolts to 31 to 36 N·m (23 to 27 lb ft).

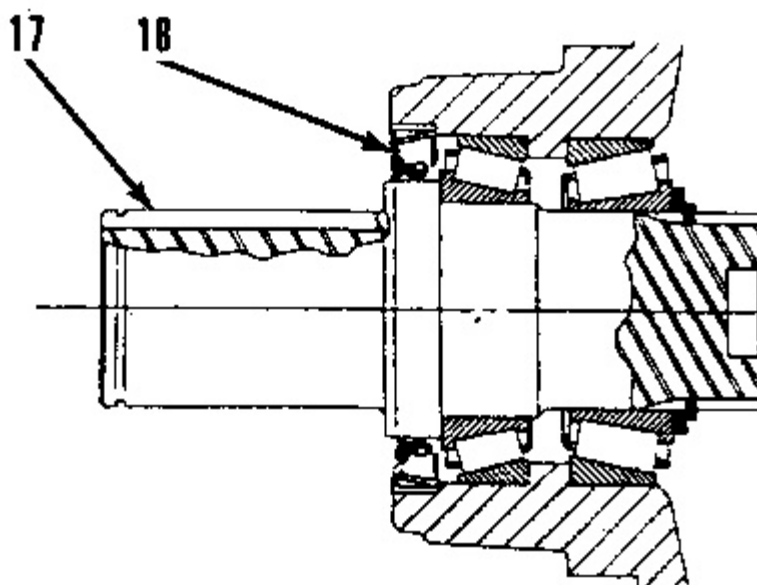

27. If the torque hub uses an output shaft (17), as shown above, install a new seal (18) as follows:

a. Apply a light film of oil to a new seal (18).

b. Position the seal so the closed end faces out. Tap the seal into place so it is flush with the hub.

28. Refill the torque hub with lubricant. See the Operation and Maintenance Manual for lubricant information.

Disassemble Rear Axle And Differential (Soma)

NOTE: Determine the style of differential by consulting the Parts Book, Form No. KEBP3661, Page 55.

Start By:

a. remove rear axle

1. Remove the drain plug at the bottom of the axle housing to drain lubricant. Replace the plug after lubricant has drained.

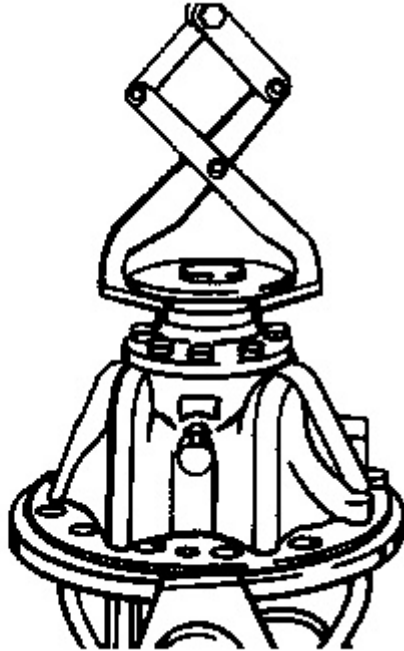

C31429P1

2. Remove the fasteners securing the differential and carrier assembly to the axle housing. Remove the differential and carrier assembly and secure to a work stand.

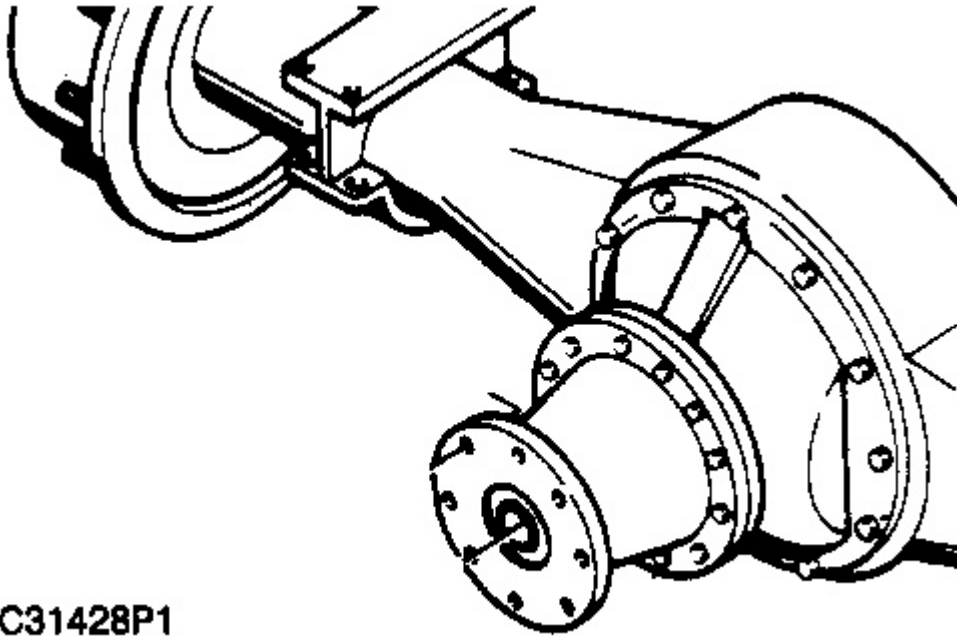

C31428P1

3. Remove the nuts, bolts, and washers securing the adapter housing to the axle. Remove the adapter housing.

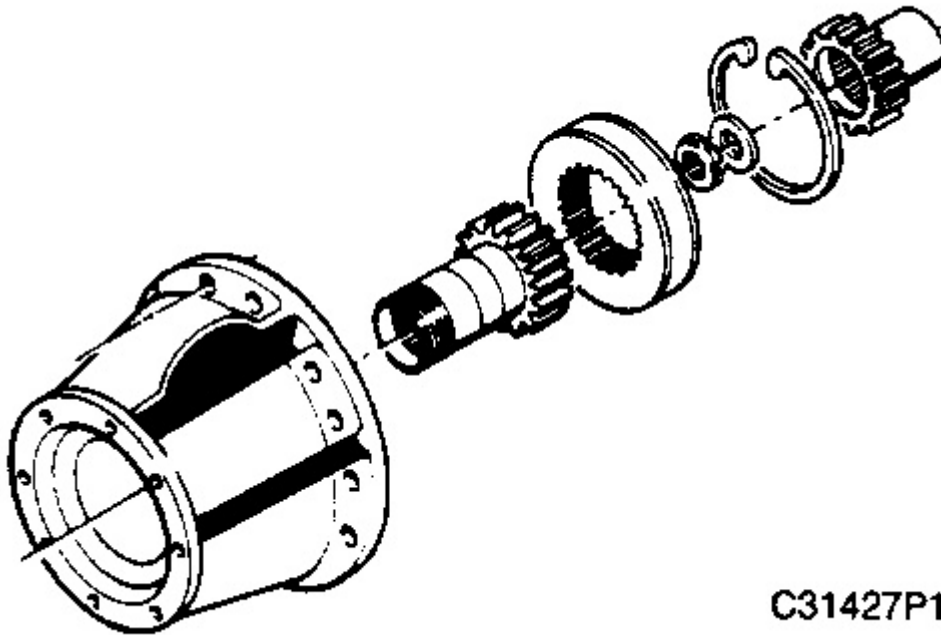

C31427P1

4. Remove the snap ring, gear coupler, and adapter gear from inside the adapter housing.

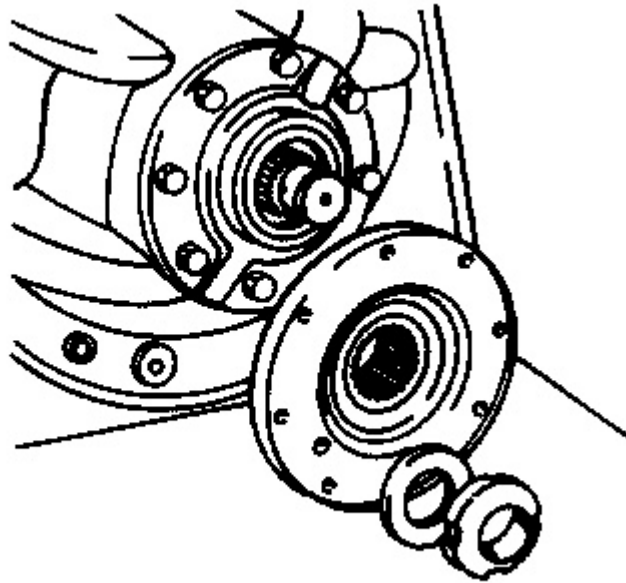

C31426P1

5. Attach a holding tool to the pinion gear to prevent it from turning. Remove the nut and washer securing the pinion gear. Remove the pinion gear.

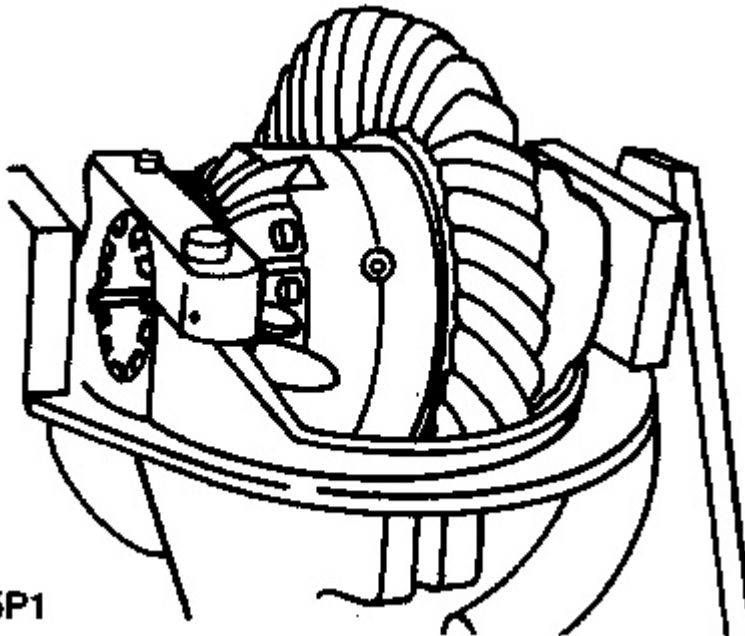

C31425P1

6. Turn the differential and carrier as shown. Remove the bolts and washers securing the lock plates at each side of the differential. Remove the lock plates.

7. Remove bolts and washers securing the bearing caps to the case.

Thank you so much for reading.
Please click the “Buy Now!”
button below to download the
complete manual.



After you pay.

You can download the most
perfect and complete manual in
the world immediately.

Our support email:

ebooklibonline@outlook.com