

Product: VIBRATORY COMPACTOR

Model: CS-583 VIBRATORY COMPACTOR 8YJ

Configuration: CS-583 VIBRATORY COMPACTOR 8YJ00001-UP (MACHINE) POWERED BY 3116 ENGINE

## Disassembly and Assembly

**446 and 446B Backhoe Loaders, Lexion 450 Combine, 3114 and 3116 Engines, IT18F Integrated Toolcarrier, D6M Track-Type Tractor and 928F, 950F and 950G Wheel Loaders**

Media Number -SEN3611-18

Publication Date -01/05/2009

Date Updated -27/05/2009

i01928788

## Exhaust Manifold - Remove and Install

SMCS - 1059-010

### Removal Procedure

Start By:

- a. Remove the turbocharger. Refer to Disassembly and Assembly, "Turbocharger - Remove".

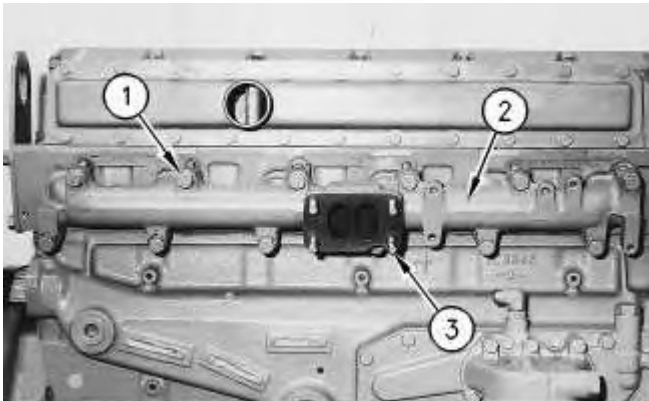

Illustration 1

g00652578

Typical example

1. Remove bolts (1), exhaust manifold (2), locks and the gaskets from the cylinder head assembly.
2. If the engine is equipped with a three-piece exhaust manifold, disassemble exhaust manifold (2) into three pieces.
3. Remove mounting studs (3) from exhaust manifold (2), if necessary.

# Installation Procedure

Table 1

Required Tools			
Tool	Part Number	Part Description	Qty
A	5P-3931	Anti-Seize Compound	1
B	2P-2333	High Temperature Sealer	1

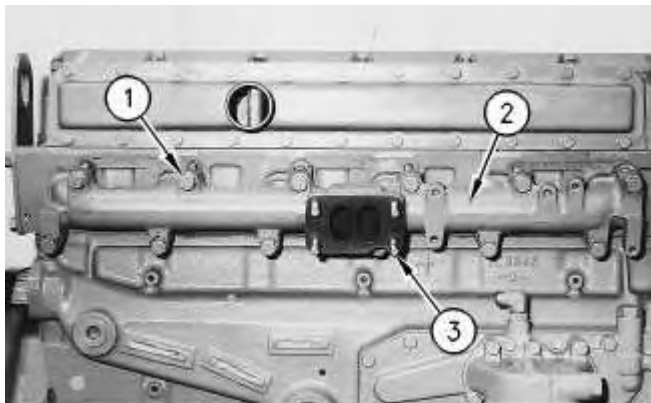
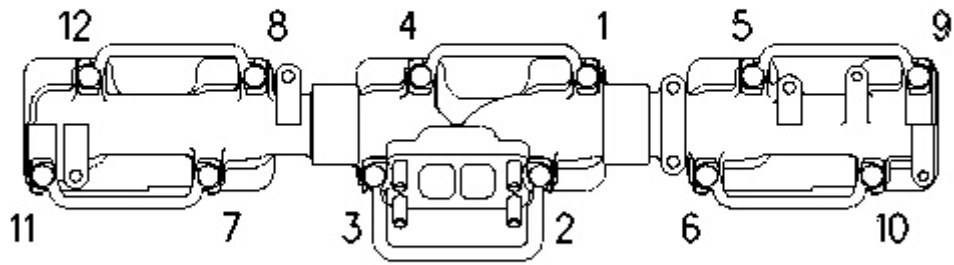

Illustration 2

g00652578

Typical example

1. Apply Tooling (A) to the threads of mounting studs (3).
2. Install mounting studs (3). Tighten mounting studs (3) to a torque of  $35 \pm 5$  N·m ( $26 \pm 4$  lb ft).
3. If the engine is equipped with a three-piece exhaust manifold, apply a thin coat of Tooling (B) to the male ends of exhaust manifold (2). Coat the inside of the female ends of exhaust manifold (2) with clean engine oil. Assemble exhaust manifold (2) and remove the excess sealant from the joints.
4. Install new exhaust manifold gaskets.
5. Apply Tooling (A) to the threads of bolts (1). Position the gaskets and exhaust manifold (2) on the cylinder head assembly. Install locks and bolts (1).



---

Illustration 3

g00617739

Typical example of a three-piece exhaust manifold

---

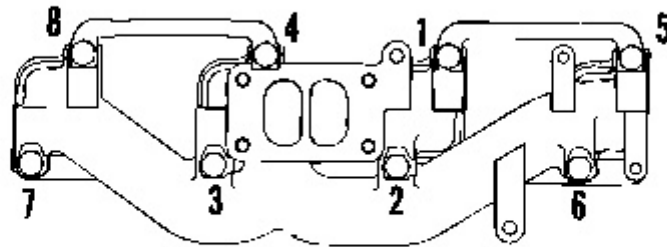

---

Illustration 4

g00641026

Exhaust manifold for a Four cylinder engine

---

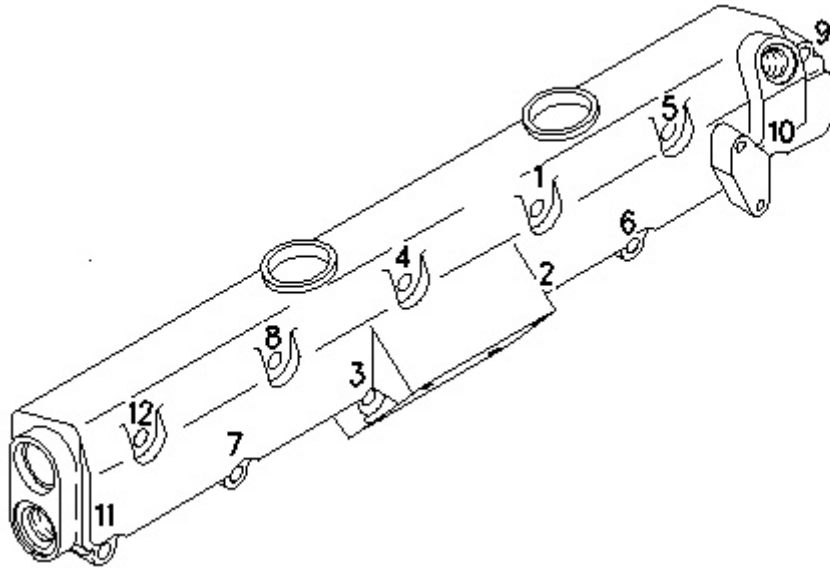

---

Illustration 5

g00641092

Water cooled exhaust manifold

6. Tighten bolts (1) in a numerical sequence to a torque of  $4 \pm 1$  N·m ( $35 \pm 9$  lb in).
7. Tighten bolts (1) in a numerical sequence to a torque of  $45 \pm 5$  N·m ( $33 \pm 4$  lb ft).

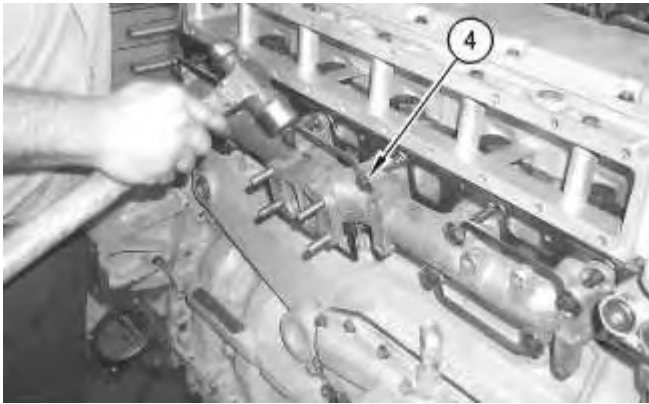

---

Illustration 6

g00675760

Typical example of locking tabs

8. Bend the locking tabs (4) over the flat of each bolt head.

**End By:**

- a. Install the turbocharger. Refer to Disassembly and Assembly, "Turbocharger - Install".
-

Product: VIBRATORY COMPACTOR

Model: CS-583 VIBRATORY COMPACTOR 8YJ

Configuration: CS-583 VIBRATORY COMPACTOR 8YJ00001-UP (MACHINE) POWERED BY 3116 ENGINE

## **Disassembly and Assembly**

**446 and 446B Backhoe Loaders, Lexion 450 Combine, 3114 and 3116 Engines, IT18F Integrated Toolcarrier, D6M Track-Type Tractor and 928F, 950F and 950G Wheel Loaders**

Media Number -SEN3611-18

Publication Date -01/05/2009

Date Updated -27/05/2009

i01328419

## **Inlet Manifold - Remove**

SMCS - 1058-011

### **Removal Procedure**

**Start By:**

- a. Remove the valve mechanism cover. Refer to Disassembly and Assembly, "Valve Mechanism Cover - Remove and Install".

---

#### **NOTICE**

**Keep all parts clean from contaminants.**

**Contaminants may cause rapid wear and shortened component life.**

---

---

#### **NOTICE**

**Care must be taken to ensure that fluids are contained during performance of inspection, maintenance, testing, adjusting, and repair of the product. Be prepared to collect the fluid with suitable containers before opening any compartment or disassembling any component containing fluids.**

**Refer to Special Publication, NENG2500, "Dealer Service Tool Catalog" for tools and supplies suitable to collect and contain fluids on Cat products.**

**Dispose of all fluids according to local regulations and mandates.**

---

1. Disconnect air inlet piping from the turbocharger to the aftercooler, if necessary.

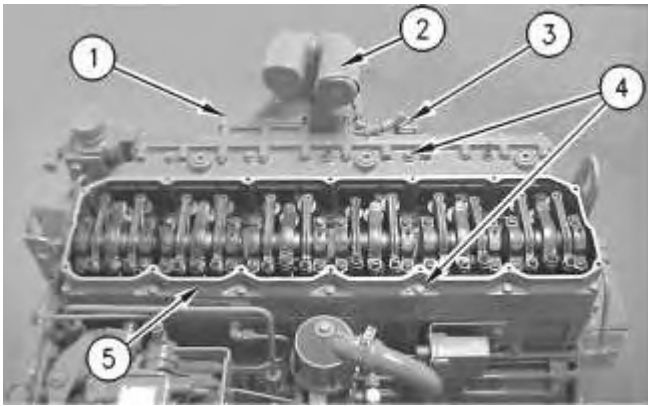

Illustration 1

g00629952

2. Remove bolts (1) and disconnect air inlet heater solenoid (3).
  3. Remove air inlet elbows (2) from air inlet manifold (5).
  4. Remove bolts (4) from air inlet manifold (5).
  5. Remove air inlet manifold (5) and the gasket.
-

Product: VIBRATORY COMPACTOR

Model: CS-583 VIBRATORY COMPACTOR 8YJ

Configuration: CS-583 VIBRATORY COMPACTOR 8YJ00001-UP (MACHINE) POWERED BY 3116 ENGINE

## **Disassembly and Assembly**

**446 and 446B Backhoe Loaders, Lexion 450 Combine, 3114 and 3116 Engines, IT18F Integrated Toolcarrier, D6M Track-Type Tractor and 928F, 950F and 950G Wheel Loaders**

Media Number -SEN3611-18

Publication Date -01/05/2009

Date Updated -27/05/2009

i01414226

## **Inlet Manifold - Install**

SMCS - 1058-012

### **Installation Procedure**

---

#### **NOTICE**

**Keep all parts clean from contaminants.**

**Contaminants may cause rapid wear and shortened component life.**

---

---

#### **NOTICE**

**Care must be taken to ensure that fluids are contained during performance of inspection, maintenance, testing, adjusting, and repair of the product. Be prepared to collect the fluid with suitable containers before opening any compartment or disassembling any component containing fluids.**

**Refer to Special Publication, NENG2500, "Dealer Service Tool Catalog" for tools and supplies suitable to collect and contain fluids on Cat products.**

**Dispose of all fluids according to local regulations and mandates.**

---



Illustration 1

g00675794

1. Install a new gasket (6) on the cylinder head.

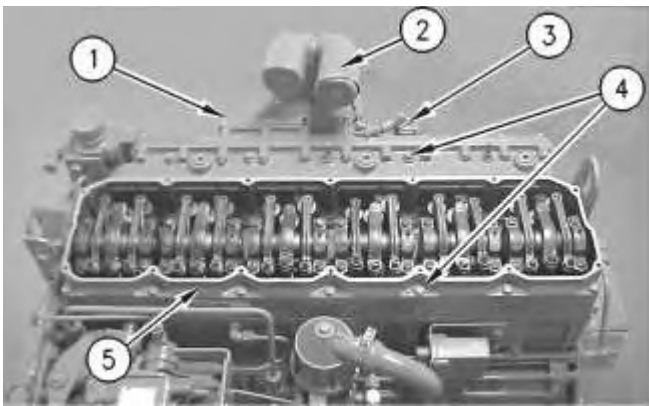

Illustration 2

g00629952

2. Position the air inlet manifold (5) on the engine.
3. Install bolts (4). Tighten the bolts to a torque of  $28 \pm 7 \text{ N}\cdot\text{m}$  ( $21 \pm 5 \text{ lb ft}$ ).
4. Install air inlet elbows (2) on air inlet manifold (5).
5. Install bolts (1) and connect air inlet heater solenoid (3).

**End By:**

- a. Install the valve mechanism cover. Refer to Disassembly and Assembly, "Valve Mechanism Cover - Remove and Install".
-



Product: VIBRATORY COMPACTOR

Model: CS-583 VIBRATORY COMPACTOR 8YJ

Configuration: CS-583 VIBRATORY COMPACTOR 8YJ00001-UP (MACHINE) POWERED BY 3116 ENGINE

## Disassembly and Assembly

**446 and 446B Backhoe Loaders, Lexion 450 Combine, 3114 and 3116 Engines, IT18F Integrated Toolcarrier, D6M Track-Type Tractor and 928F, 950F and 950G Wheel Loaders**

Media Number -SEN3611-18

Publication Date -01/05/2009

Date Updated -27/05/2009

i01943334

## Inlet and Exhaust Valves - Remove and Install

SMCS - 1105-010

### Removal Procedure

Table 1

Required Tools			
Tool	Part Number	Part Description	Qty
A	5S-1330	Valve Spring Compressor	1

#### Start By:

- Remove the cylinder head assembly. Refer to Disassembly and Assembly, "Cylinder Head - Remove".

---

### NOTICE

**Keep all parts clean from contaminants.**

**Contaminants may cause rapid wear and shortened component life.**

---

**Note:** For information on the reusability of the inlet valves, the exhaust valves and the springs, refer to Guideline For Reusable Parts And Salvage Operations, SEBF8002, "Valves, Valve Springs, Valve Rotators, and Locks", Guideline For Reusable Parts And Salvage Operations, SEBF8034, "Valve and Valve Spring Specifications", and Guideline For Reusable Parts And Salvage Operations, SEBF8162, "Specifications to Measure and Salvage Cylinder Head Assemblies and Related Components".

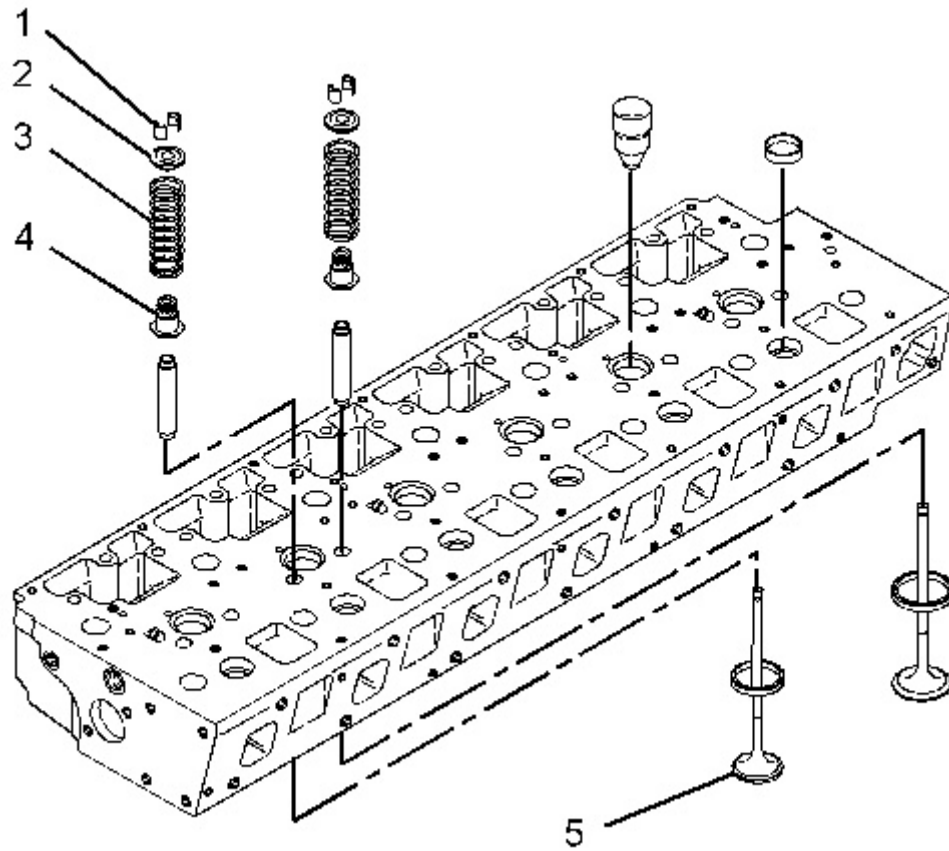

Illustration 1

g01011225

**Note:** The following components of the exhaust valves are different from the components of the inlet valves: spring retainer (2), valve spring (3) and valve (5).

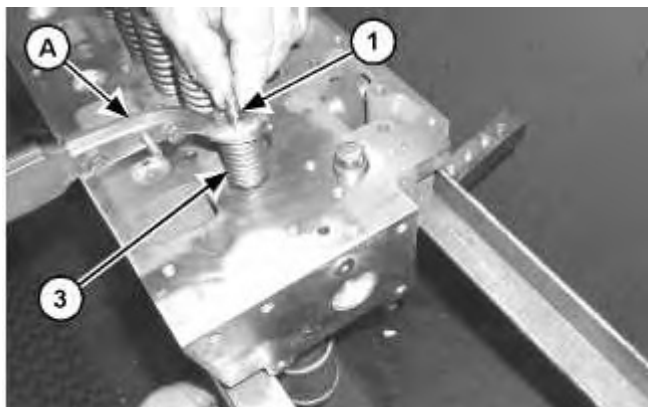

Illustration 2

g01011269

1. Use Tooling (A) to compress valve spring (3). Remove retainer lock (1).
2. Remove Tooling (A).
3. Remove spring retainer (2). Remove valve spring (3).

4. Remove valve seal (4) and valve (5).
5. Repeat Steps 1 through 4 in order to remove the remaining inlet valves and exhaust valves.

## Installation Procedure

Table 2

Required Tools			
Tool	Part Number	Part Description	Qty
A	5S-1330	Valve Spring Compressor	1

---

### NOTICE

**Keep all parts clean from contaminants.**

**Contaminants may cause rapid wear and shortened component life.**

---

**Note:** For information on the reusability of the inlet valves, the exhaust valves and the springs, refer to Guideline For Reusable Parts And Salvage Operations, SEBF8002, "Valves, Valve Springs, Valve Rotators, and Locks", Guideline For Reusable Parts And Salvage Operations, SEBF8034, "Valve and Valve Spring Specifications", and Guideline For Reusable Parts And Salvage Operations, SEBF8162, "Specifications to Measure and Salvage Cylinder Head Assemblies and Related Components".

---

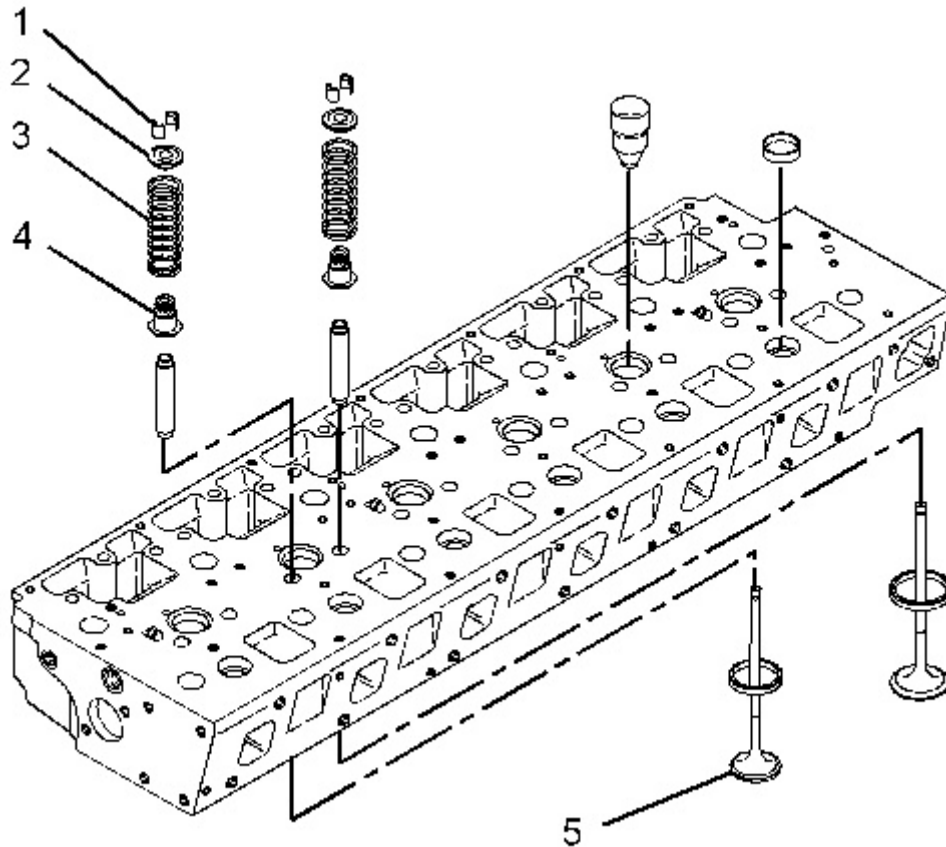

Illustration 3

g01011225

1. Lubricate valve (5) with clean engine oil. Install valve (5) in the cylinder head assembly. Install new valve seal (4) against the valve guide.
2. Place the following items on the valve stem: valve spring (3) and spring retainer (2).

 **WARNING**

**The valve keepers can be thrown from the valve when the valve spring compressor is released. Ensure that the valve keepers are properly installed on the valve stem. To help prevent personal injury, keep away from the front of the valve keepers and valve springs during the installation of the valves.**

**Note:** A small amount of grease can be used to hold retainer locks (1) in position during installation.

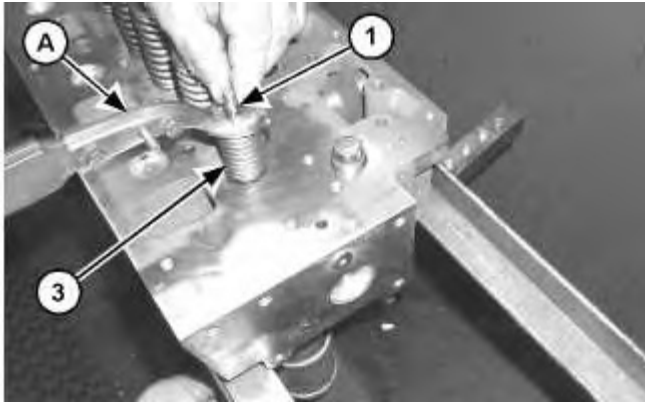

---

Illustration 4

g01011269

3. Use Tooling (A) to compress valve spring (3). Install retainer lock (1).
4. Repeat Steps 1 through 3 in order to install the remaining inlet valves and exhaust valves.

**End By:**

- a. Install the cylinder head assembly. Refer to Disassembly and Assembly, "Cylinder Head - Install".
-

Product: VIBRATORY COMPACTOR

Model: CS-583 VIBRATORY COMPACTOR 8YJ

Configuration: CS-583 VIBRATORY COMPACTOR 8YJ00001-UP (MACHINE) POWERED BY 3116 ENGINE

## Disassembly and Assembly

**446 and 446B Backhoe Loaders, Lexion 450 Combine, 3114 and 3116 Engines, IT18F Integrated Toolcarrier, D6M Track-Type Tractor and 928F, 950F and 950G Wheel Loaders**

Media Number -SEN3611-18

Publication Date -01/05/2009

Date Updated -27/05/2009

i01961680

# Inlet and Exhaust Valve Guides - Remove and Install

SMCS - 1104-010

## Removal Procedure

Table 1

Required Tools			
Tool	Part Number	Part Description	Qty
A	1U-7793	Valve Guide Driver <sup>(1)</sup>	1

<sup>(1)</sup> Part of 1U-6685 Valve Guide Tool Kit

### Start By:

- A. Remove the inlet and exhaust valves. Refer to Disassembly and Assembly, "Inlet and Exhaust Valves - Remove and Install".

---

## NOTICE

**Keep all parts clean from contaminants.**

**Contaminants may cause rapid wear and shortened component life.**

---

**Note:** For information on the reusability of the valve guides, refer to Guideline For Reusable Parts And Salvage Operations, SEBF8218, "Specifications for Cylinder Head Assemblies 3114, 3116, and 3126 Engines" and Guideline For Reusable Parts And Salvage Operations, SEBF8162, "Procedure to Measure and Salvage Cylinder Head Assemblies and Related Components".

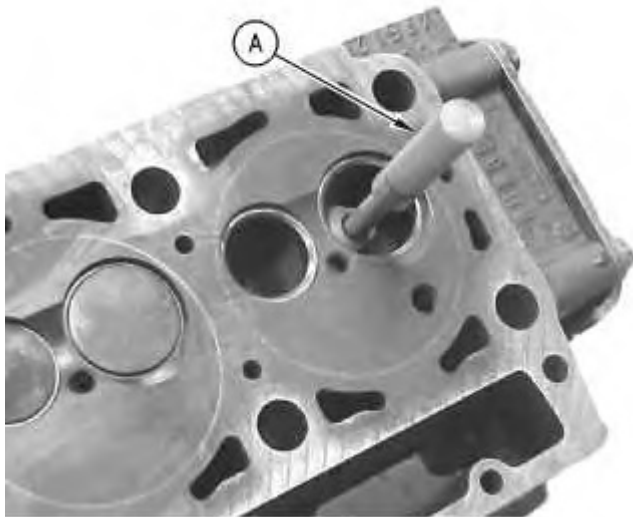

Illustration 1

g00745735

Typical example

1. Use Tooling (A) to remove the inlet valve guides from the cylinder head assembly. Use Tooling (A) to remove the exhaust valve guides from the cylinder head assembly.

## Installation Procedure

Table 2

Required Tools			
Tool	Part Number	Part Description	Qty
A	1U-7793	Valve Guide Driver <sup>(1)</sup>	1
B	1U-7792	Guide Collar <sup>(1)</sup>	1
C	9U-6895	Valve Guide Driver	1
D	149-4008	Guide Collar	1

<sup>(1)</sup> Part of **1U-6685** Valve Guide Tool Kit

---

### NOTICE

**Keep all parts clean from contaminants.**

**Contaminants may cause rapid wear and shortened component life.**

---

**Note:** For information on the reusability of the valve guides, refer to Guideline For Reusable Parts And Salvage Operations, SEBF8218, "Specifications for Cylinder Head Assemblies 3114, 3116, and 3126 Engines" and Guideline For Reusable Parts And Salvage Operations, SEBF8162, "Procedure to Measure and Salvage Cylinder Head Assemblies and Related Components".

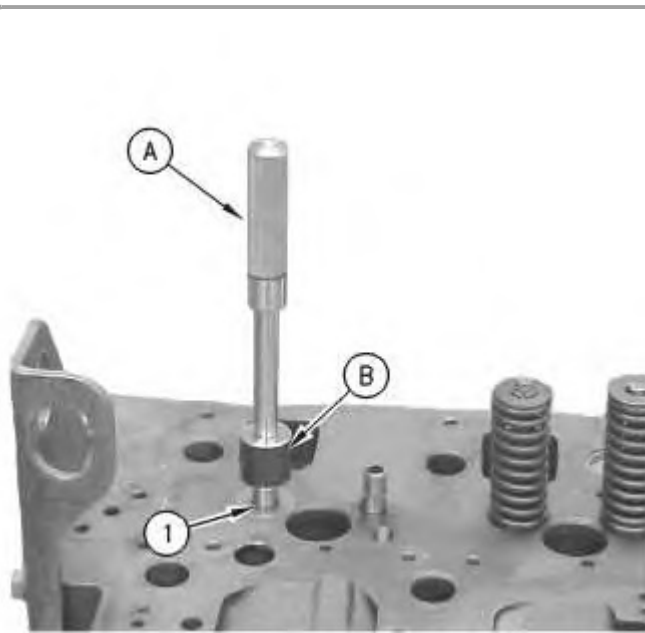

---

Illustration 2

g00745782

Typical example

1. Position inlet valve guide (1) and tap on the top of inlet valve guide (1). This is done in order to start inlet valve guide (1) into the cylinder head assembly.
  2. Use Tooling (A) and Tooling (B) to install inlet valve guide (1). Install inlet valve guides (1) until tooling (B) contacts the cylinder head.
-



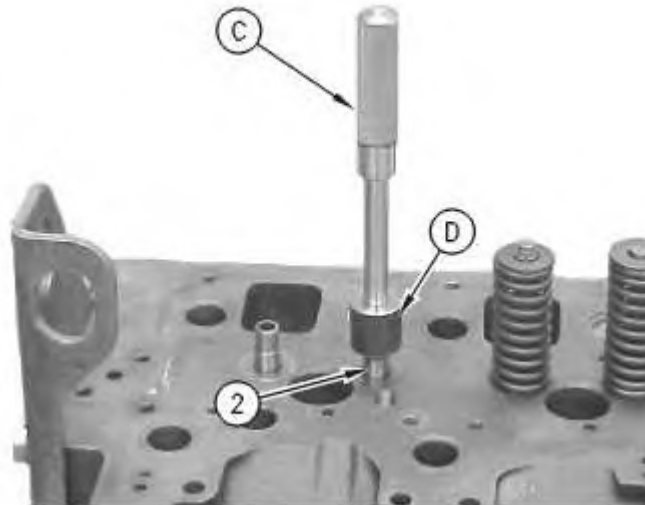

---

Illustration 3

g00745672

Typical example

3. Position exhaust valve guide (2) and tap on the top of exhaust valve guide (2). This is done in order to start the exhaust valve guide into the cylinder head assembly.

**Note:** Some of the early engines have inlet valves and exhaust valves that are identical in size. Use the same specifications and the same tools for both valves. Proceed to Step 4 if the valves are not the same size.

4. Use Tooling (C) and Tooling (D) to install exhaust valve guide (2). Install inlet valve guides (2) until tooling (D) contacts the cylinder head.

**End By:** Install the inlet and exhaust valves. Refer to Disassembly and Assembly, "Inlet and Exhaust Valves - Remove and Install".

---

Product: VIBRATORY COMPACTOR

Model: CS-583 VIBRATORY COMPACTOR 8YJ

Configuration: CS-583 VIBRATORY COMPACTOR 8YJ00001-UP (MACHINE) POWERED BY 3116 ENGINE

## Disassembly and Assembly

**446 and 446B Backhoe Loaders, Lexion 450 Combine, 3114 and 3116 Engines, IT18F Integrated Toolcarrier, D6M Track-Type Tractor and 928F, 950F and 950G Wheel Loaders**

Media Number -SEN3611-18

Publication Date -01/05/2009

Date Updated -27/05/2009

i01929146

# Inlet and Exhaust Valve Seat Inserts - Remove and Install

SMCS - 1103-010

## Removal Procedure

Table 1

Required Tools			
Tool	Part Number	Part Description	Qty
A <sup>(1)</sup>	6V-4194	Valve Seat Extractor	1
B <sup>(1)</sup>	165-5647	Valve Seat Extractor	1
C <sup>(1)</sup>	6V-4804	Handle	1
D <sup>(1)</sup>	6V-4192	Threaded Shaft	1
E <sup>(1)</sup>	6V-4199	Lifting Bracket	1

<sup>(1)</sup> Part of the **166-7441** Valve Seat Extractor Tool

### Start By:

- a. Remove the inlet and exhaust valves. Refer to Disassembly and Assembly, "Inlet and Exhaust Valves - Remove and Install".

---

### NOTICE

**Keep all parts clean from contaminants.**

**Contaminants may cause rapid wear and shortened component life.**

---

**Note:** For information on the reusability of the valve seats, refer to Guideline For Reusable Parts And Salvage Operations, SEBF8218, "Specifications for Cylinder Head Assemblies 3114, 3116, and 3126 Engines".

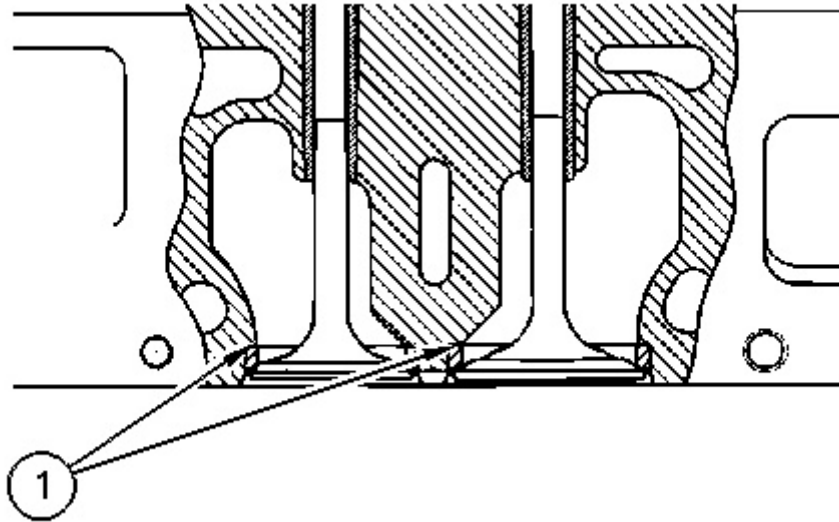

---

Illustration 1

g00615519

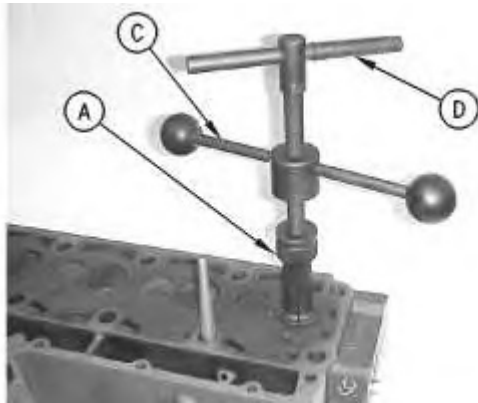

---

Illustration 2

g00656459

**Note:** Replace Tooling (A) with Tooling (B) for the removal of the inlet valve seat insert.

1. Install Tooling (A) in the exhaust valve seat insert.
  2. Install Tooling (C) and Tooling (D) in Tooling (A). Hand tighten Tooling (D). Tooling (A) will expand below the edge of valve seat insert (1).
-

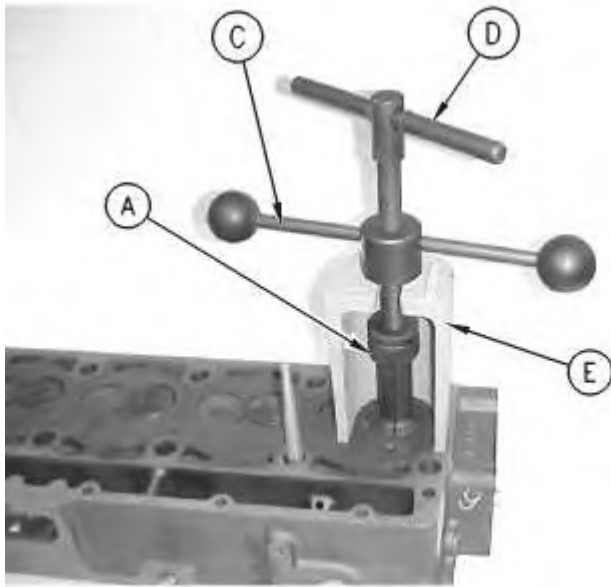

Illustration 3

g00656462

3. Install Tooling (E) on the cylinder head under Tooling (C). Hold Tooling (D) while you turn Tooling (C). Remove valve seat insert (1).

## Installation Procedure

Table 2

Required Tools			
Tool	Part Number	Part Description	Qty
F	1U-6685	Guide and Insert Tool Group	1

### NOTICE

**Keep all parts clean from contaminants.**

**Contaminants may cause rapid wear and shortened component life.**

**Note:** For information on the reusability of the valve seats, refer to Guideline For Reusable Parts And Salvage Operations, SEBF8218, "Specifications for Cylinder Head Assemblies 3114, 3116, and 3126 Engines".

1. Cool the valve seat inserts for easier installation.

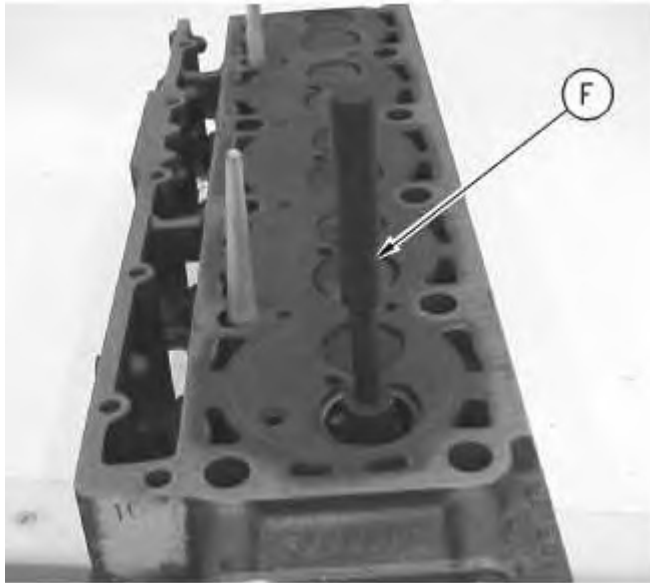

---

Illustration 4

g01003799

2. Turn Tooling (F) upside-down and use Tooling (F) and a press to install the valve seat inserts in the cylinder head assembly.
3. After the valve seat inserts are installed, grind the inserts to the final specification. Refer to Guideline for Reusable Parts and Salvage Operation, SEBF8218, "Specifications for Cylinder Head Assemblies 3114, 3116, and 3126 Engines" for the specifications.

**End By:**

- a. Install the inlet valves and exhaust valves. Refer to Disassembly and Assembly, "Inlet and Exhaust Valves - Remove and Install".
-

Product: VIBRATORY COMPACTOR

Model: CS-583 VIBRATORY COMPACTOR 8YJ

Configuration: CS-583 VIBRATORY COMPACTOR 8YJ00001-UP (MACHINE) POWERED BY 3116 ENGINE

## Disassembly and Assembly

**446 and 446B Backhoe Loaders, Lexion 450 Combine, 3114 and 3116 Engines, IT18F Integrated Toolcarrier, D6M Track-Type Tractor and 928F, 950F and 950G Wheel Loaders**

Media Number -SEN3611-18

Publication Date -01/05/2009

Date Updated -27/05/2009

i01929163

## Engine Oil Filter Base - Remove

SMCS - 1306-011

### Removal Procedure

Table 1

Required Tools			
Tool	Part Number	Part Description	Qty
A	185-3630	Strap Wrench	1

#### Start By:

- a. Remove the turbocharger. Refer to Disassembly and Assembly, "Turbocharger - Remove".

---

#### NOTICE

**Keep all parts clean from contaminants.**

**Contaminants may cause rapid wear and shortened component life.**

---

#### NOTICE

**Care must be taken to ensure that fluids are contained during performance of inspection, maintenance, testing, adjusting, and repair of the product. Be prepared to collect the fluid with suitable containers**

**before opening any compartment or disassembling any component containing fluids.**

**Refer to Special Publication, NENG2500, "Dealer Service Tool Catalog" for tools and supplies suitable to collect and contain fluids on Cat products.**

**Dispose of all fluids according to local regulations and mandates.**

---

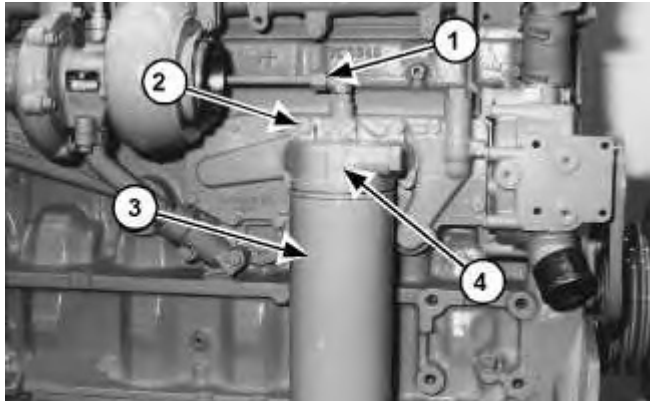

Illustration 1

g01009468

1. Use Tooling (A) to remove engine oil filter (3).
  2. Disconnect the tube assembly for the turbocharger inlet (1) from the engine oil filter base (4).
  3. Remove bolts (2) and the washers that hold engine oil filter base (4) to the cylinder block.
  4. Remove engine oil filter base (4) and the gasket.
-

Product: VIBRATORY COMPACTOR

Model: CS-583 VIBRATORY COMPACTOR 8YJ

Configuration: CS-583 VIBRATORY COMPACTOR 8YJ00001-UP (MACHINE) POWERED BY 3116 ENGINE

## Disassembly and Assembly

**446 and 446B Backhoe Loaders, Lexion 450 Combine, 3114 and 3116 Engines, IT18F Integrated Toolcarrier, D6M Track-Type Tractor and 928F, 950F and 950G Wheel Loaders**

Media Number -SEN3611-18

Publication Date -01/05/2009

Date Updated -27/05/2009

i01929612

## Engine Oil Filter Base - Disassemble

SMCS - 1306-015

### Disassembly Procedure

Start By:

- a. Remove the engine oil filter base. Refer to Disassembly and Assembly, "Engine Oil Filter Base - Remove".

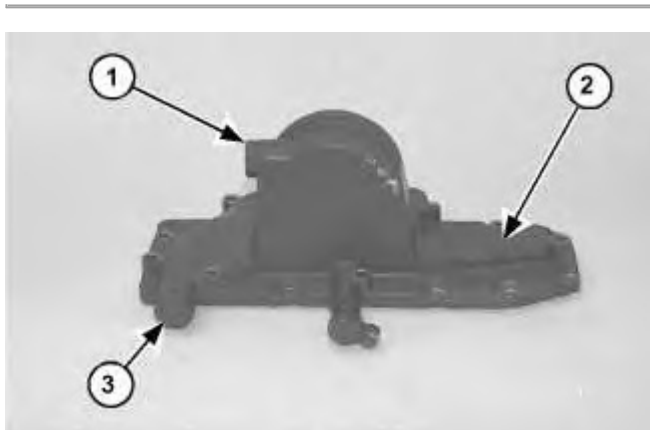

Illustration 1

g01011623



**Personal injury can result from being struck by parts propelled by a released spring force.**



**Make sure to wear all necessary protective equipment.**

**Follow the recommended procedure and use all recommended tooling to release the spring force.**

---

1. Remove plugs (1) and (3) from oil filter base (2).

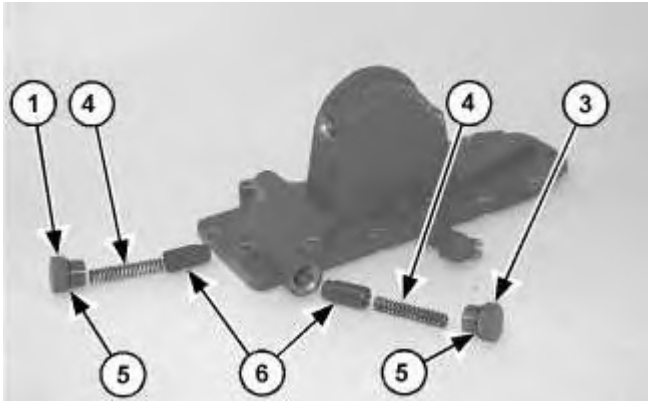

Illustration 2

g01011627

2. Remove springs (4) and valves (6). Remove O-ring seals (5) from plugs (1) and (3). Inspect the parts for wear or damage. If the parts are worn or damaged, use new parts for replacement.
-

Thank you so much for reading.  
Please click the “Buy Now!”  
button below to download the  
complete manual.



After you pay.

You can download the most  
perfect and complete manual in  
the world immediately.

Our support email:

[ebooklibonline@outlook.com](mailto:ebooklibonline@outlook.com)