

Product: VIBRATORY COMPACTOR

Model: CS-64B VIBRATORY COMPACTOR CW6

Configuration: CS66B, CS64B Vibratory Soil Compactor CW600001-UP (MACHINE) POWERED BY C4.4 Engine

Disassembly and Assembly

C4.4 Engines for Caterpillar Built Machines

Media Number -UENR4516-11

Publication Date -01/06/2015

Date Updated -29/10/2018

i05820286

Front Cover - Remove and Install

SMCS - 1166-010

Removal Procedure

Start By:

- a. Remove the crankshaft pulley. Refer to Disassembly and Assembly, "Crankshaft Pulley - Remove and Install" for the correct procedure.
 - b. If the engine has a fan, remove the fan. Refer to Disassembly and Assembly, "Fan - Remove and Install" for the correct procedure.
-

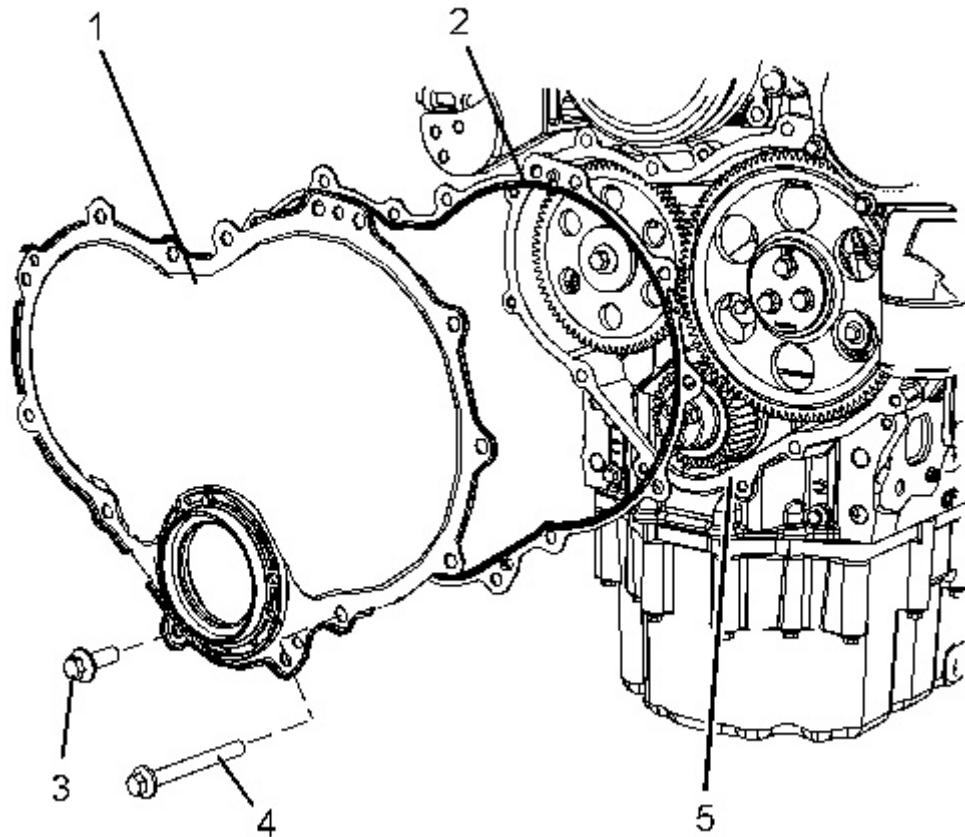

Illustration 1

g02481028

1. Remove the front seal from the front cover. Refer to Disassembly and Assembly, "Crankshaft Front Seal - Remove and Install" for the correct procedure.
2. Remove bolts (3) and bolts (4). Identify the positions of bolts of different length.
3. Remove front cover (1) from front housing (5).
4. Remove gasket (2).

Installation Procedure

Table 1

| Required Tools | | | |
|----------------|-------------|----------------------------|-----|
| Tool | Part Number | Part Description | Qty |
| A | - | Guide Studs M8 by 70 mm | 2 |
| B | 342-9206 | Front Cover Alignment Tool | 1 |

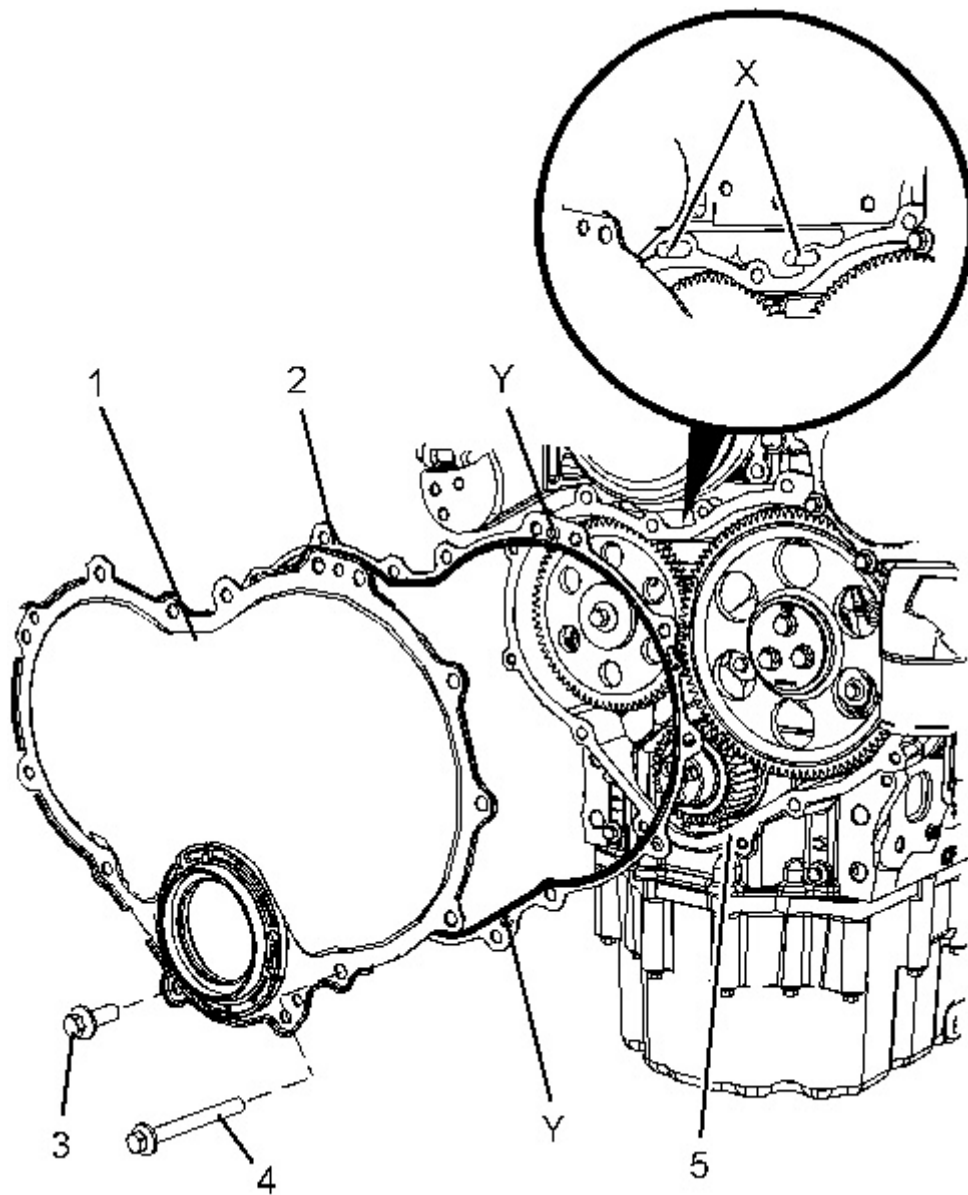

Illustration 2

g02481030

1. Thoroughly clean the gasket surface of the front housing.
2. If the original front cover is installed, follow Step 2.a through Step 2.b.
 - a. Thoroughly clean front cover (1).
 - b. Install a new gasket (2) to front cover (1). Engage Locators (Y) into the holes in the front cover.
3. Install Tooling (A) into Holes (X) in front housing (5).
4. Use Tooling (A) in order to position the front cover assembly onto the front housing.
5. Install bolts (3) and bolts (4) finger tight. Ensure that the bolts of different length are installed in the correct positions.

6. Install a new front seal to the front cover. Refer to Disassembly and Assembly, "Crankshaft Front Seal - Remove and Install" for the correct procedure.
7. Use Tooling (B) in order to align the front cover.
8. Remove Tooling (A) and install the remaining bolts.
9. Tighten bolts (3) and bolts (4) to a torque of 22 N·m (195 lb in).
10. Remove Tooling (B) from the front cover.

End By:

- a. Install the crankshaft pulley. Refer to Disassembly and Assembly, "Crankshaft Pulley - Remove and Install" for the correct procedure.
 - b. If the engine has a fan, install the fan. Refer to Disassembly and Assembly, "Fan - Remove and Install" for the correct procedure.
-

Product: VIBRATORY COMPACTOR

Model: CS-64B VIBRATORY COMPACTOR CW6

Configuration: CS66B, CS64B Vibratory Soil Compactor CW600001-UP (MACHINE) POWERED BY C4.4 Engine

Disassembly and Assembly

C4.4 Engines for Caterpillar Built Machines

Media Number -UENR4516-11

Publication Date -01/06/2015

Date Updated -29/10/2018

i05820287

Front Cover - Remove and Install - Heavy Duty Front Cover

SMCS - 1166-010

Removal Procedure

Start By:

- a. Remove the crankshaft pulley. Refer to Disassembly and Assembly, "Crankshaft Pulley - Remove and Install" for the correct procedure.
 - b. If the engine has a fan, remove the fan. Refer to Disassembly and Assembly, "Fan - Remove and Install" for the correct procedure.
-

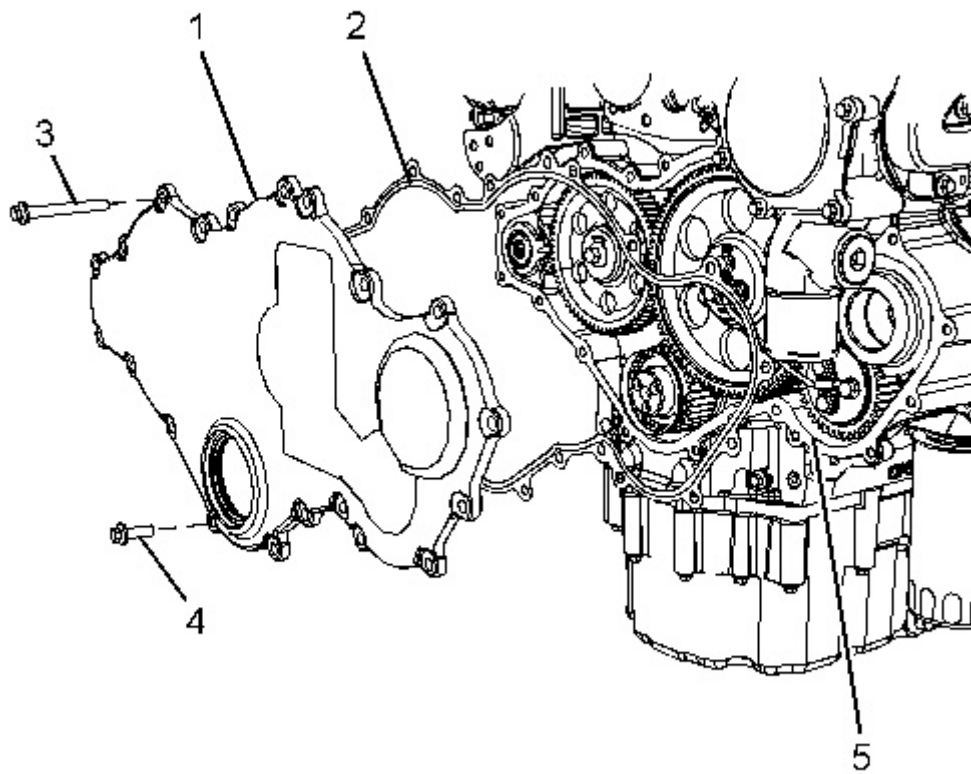

Illustration 1

g02480997

1. Remove the front seal from the front cover. Refer to Disassembly and Assembly, "Crankshaft Front Seal - Remove and Install" for the correct procedure.
2. Remove bolts (3) and bolts (4). Identify the positions of bolts of different length.
3. Remove front cover (1) from front housing (5).
4. Remove gasket (2).

Installation Procedure

Table 1

| Required Tools | | | |
|----------------|-------------|----------------------------|-----|
| Tool | Part Number | Part Description | Qty |
| A | - | Guide Studs M8 by 70 mm | 2 |
| B | 364-7209 | Front Cover Alignment Tool | 1 |

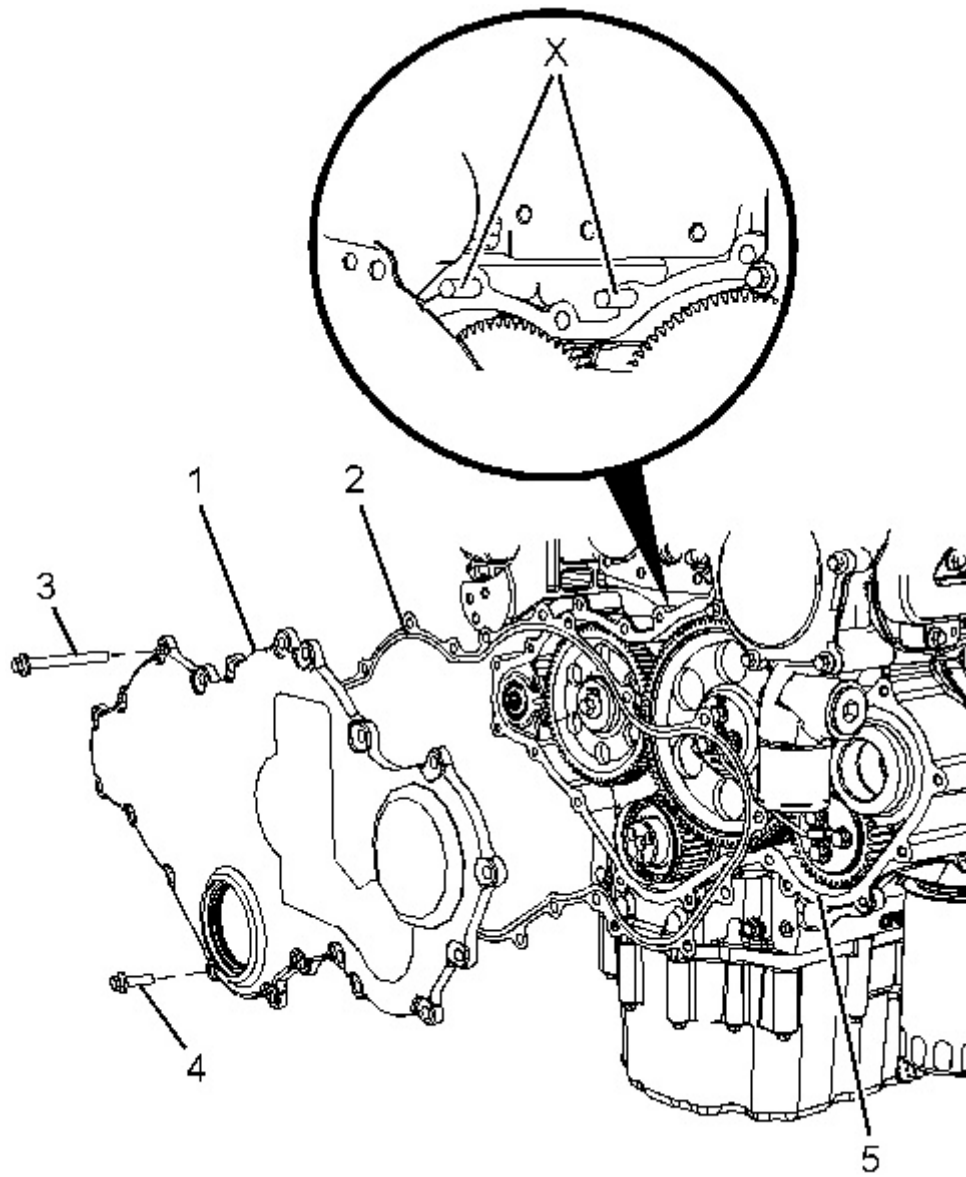

Illustration 2

g02480998

1. Ensure that all components are clean and free from damage. Replace any damaged components.
2. Thoroughly clean the gasket surface of front housing (5).
3. Thoroughly clean front cover (1).
4. Install Tooling (A) into Holes (X) in front housing (5).
5. Install a new gasket (2) onto Tooling (A).
6. Install front cover (1) onto Tooling (A).
7. Install bolts (3) and bolts (4) finger tight. Ensure that the bolts of different length are installed in the correct positions.
8. Use Tooling (B) to align the front cover assembly.

9. Remove Tooling (A) and install the remaining bolts.
10. Tighten bolts (3) and bolts (4) to a torque of 22 N·m (195 lb in).
11. Remove Tooling (B).
12. Install a new front seal to the front cover. Refer to Disassembly and Assembly, "Crankshaft Front Seal - Remove and Install" for the correct procedure.

End By:

- a. Install the crankshaft pulley. Refer to Disassembly and Assembly, "Crankshaft Pulley - Remove and Install" for the correct procedure.
 - b. If the engine has a fan, install the fan. Refer to Disassembly and Assembly, "Fan - Remove and Install" for the correct procedure.
-

Product: VIBRATORY COMPACTOR

Model: CS-64B VIBRATORY COMPACTOR CW6

Configuration: CS66B, CS64B Vibratory Soil Compactor CW600001-UP (MACHINE) POWERED BY C4.4 Engine

Disassembly and Assembly C4.4 Engines for Caterpillar Built Machines

Media Number -UENR4516-11

Publication Date -01/06/2015

Date Updated -29/10/2018

i05820288

Gear Group (Front) - Remove and Install

SMCS - 1206-010

Removal Procedure

Table 1

| Required Tools | | | |
|----------------|-------------|-------------------------------------|-----|
| Tool | Part Number | Part Description | Qty |
| A | 9U-7336 | Housing | 1 |
| | 5P-7305 | Engine Turning Tool | 1 |
| B | 230-6284 | Timing Pin (Camshaft) | 1 |
| C | 364-9107 | Timing Pin (Fuel Injection Pump) | 1 |
| D | 136-4632 | Timing Pin (Crankshaft) | 1 |
| | 268-1966 | Adapter | 1 |
| E | 298-5564 | T40 Torx Socket | 1 |

Start By:

- a. Remove the front cover. Refer to Disassembly and Assembly, "Front Cover - Remove and Install" for the correct procedure.
- b. Remove the valve mechanism cover. Refer to Disassembly and Assembly, "Valve Mechanism Cover - Remove and Install" for the correct procedure.

NOTICE

Keep all parts clean from contaminants.

Contaminants may cause rapid wear and shortened component life.

NOTICE

Care must be taken to ensure that fluids are contained during performance of inspection, maintenance, testing, adjusting and repair of the product. Be prepared to collect the fluid with suitable containers before opening any compartment or disassembling any component containing fluids.

Dispose of all fluids according to local regulations and mandates.

Note: Care must be taken in order to ensure that the fuel injection pump timing is not lost during the removal of the front gear group. Carefully follow the procedure in order to remove the gear group.

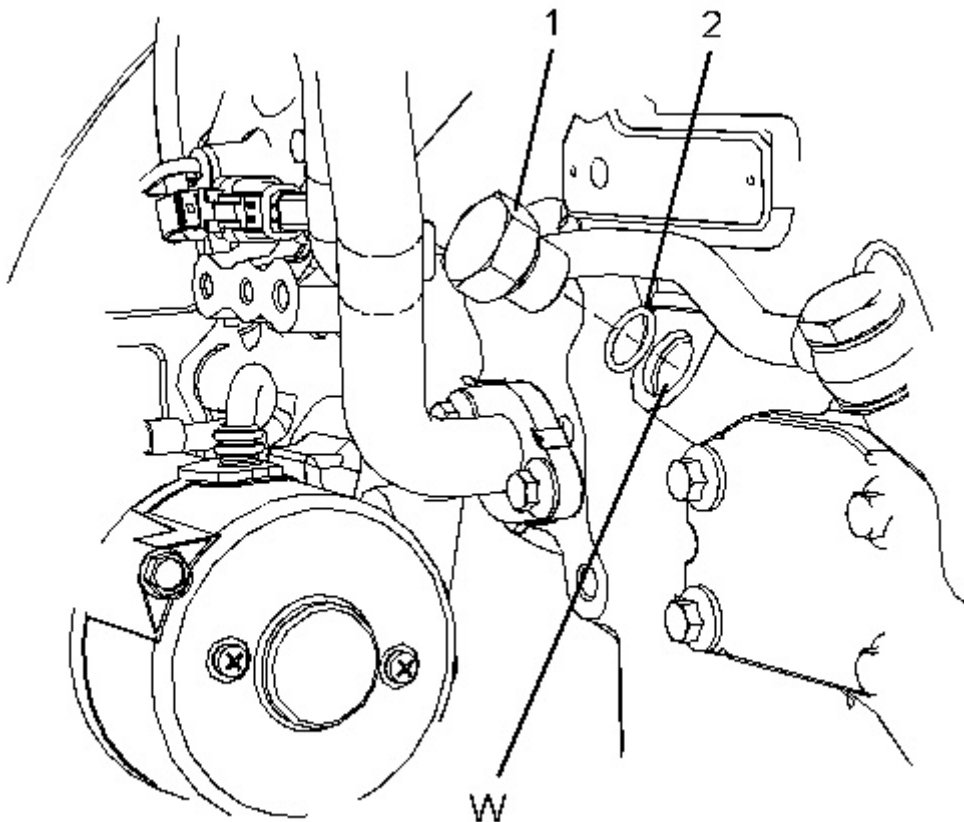

1. Remove plug (1) from the cylinder block. Remove O-ring seal (2) from the plug.
 2. Use Tooling (A) in order to rotate the crankshaft so that number one piston is at top dead center on the compression stroke. Refer to System Operation, Testing and Adjusting, "Finding Top Center Position for No.1 Piston" for the correct procedure. Install Tooling (D) through Hole (W) in order to lock the crankshaft so that number one piston is at top dead center on the compression stroke.
 3. Remove Tooling (D).
 4. Use Tooling (A) in order to rotate the crankshaft in a clockwise direction and position the crankshaft at the safe position. Refer to System Operation, Testing and Adjusting, "Position the Valve Mechanism Before Maintenance Procedures" for the correct procedure.
-

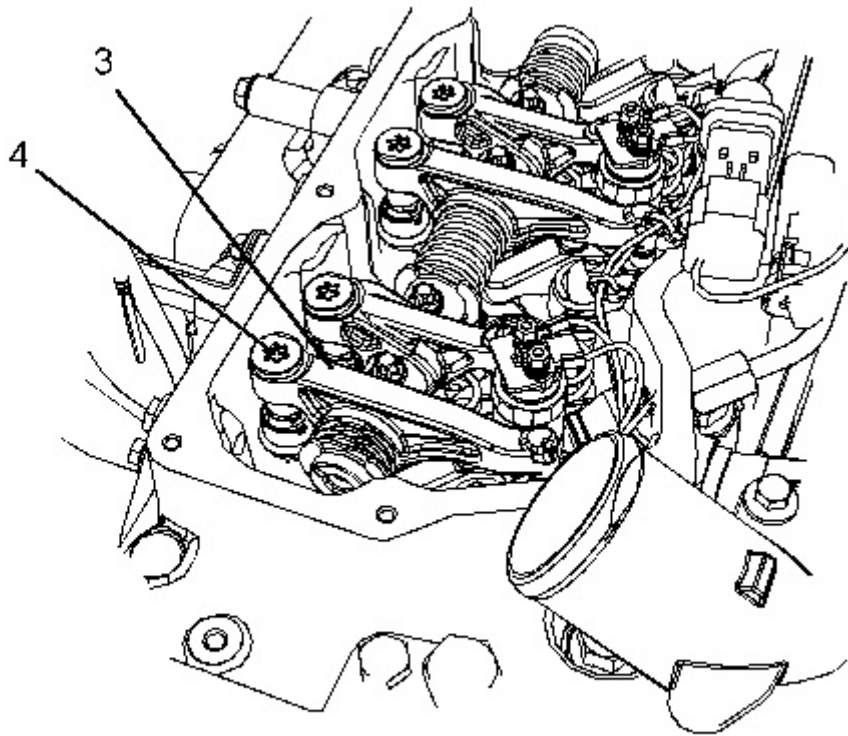

Illustration 2

g03707478

5. Use Tooling (E) in order to loosen threaded inserts (4) on all rocker arms (3). Unscrew threaded inserts (4) on all rocker arms (3) until all valves are fully closed.

Note: Ensure that ALL threaded inserts are fully unscrewed.

6. Use Tooling (A) in order to rotate the crankshaft so that number one piston is at top dead center on the compression stroke. Refer to System Operation, Testing and Adjusting, "Finding Top Center Position for No.1 Piston" for the correct procedure. Install Tooling (D) through Hole (W) in order to lock the crankshaft so that number one piston is at top dead center on the compression stroke. Refer to Illustration 1.
-

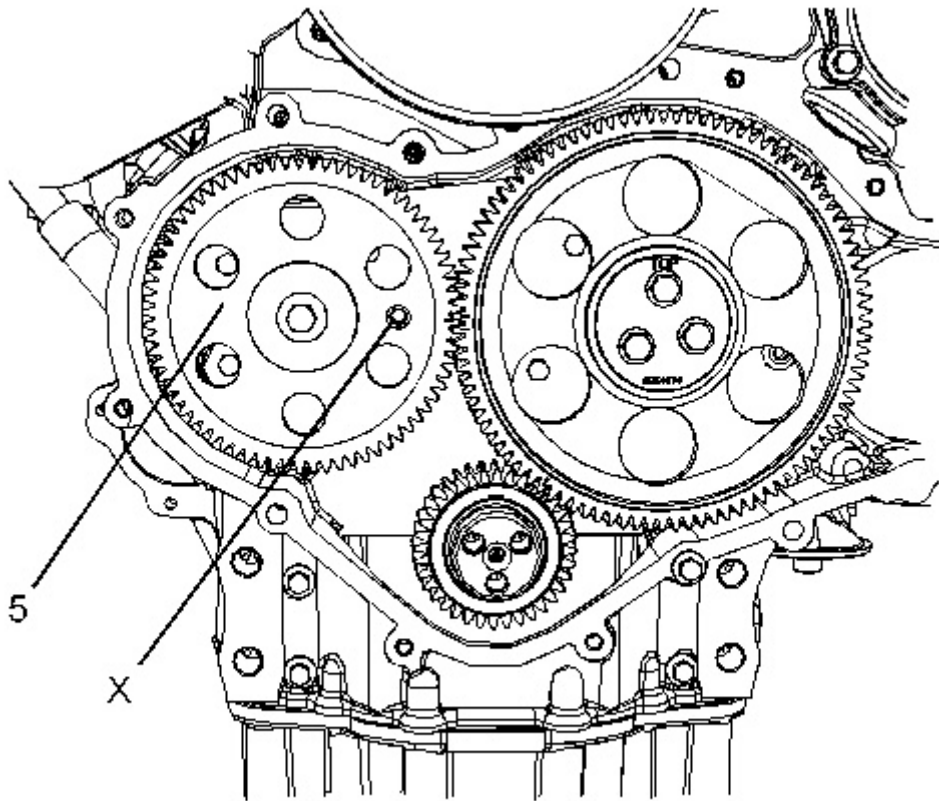

Illustration 3

g03707479

7. Install Tooling (B) through Hole (X) in camshaft gear (5) into the front housing. Use Tooling (B) in order to lock the camshaft in the correct position. Refer to System Operation, Testing and Adjusting, "Finding Top Center Position for No.1 Piston" for the correct procedure.
8. Install Tooling (D) into Hole (W) in the cylinder block. Use Tooling (D) in order to lock the crankshaft in the correct position. Refer to System Operation, Testing and Adjusting, "Finding Top Center Position for No.1 Piston" for the correct procedure.

Note: Do not use excessive force to install Tooling (D). Do not use Tooling (D) to hold the crankshaft during repairs.

9. Use Tooling (C) in order to lock the fuel injection pump gear in the correct position. Refer to Disassembly and Assembly, "Fuel Injection Pump - Remove" for the correct procedure.
-

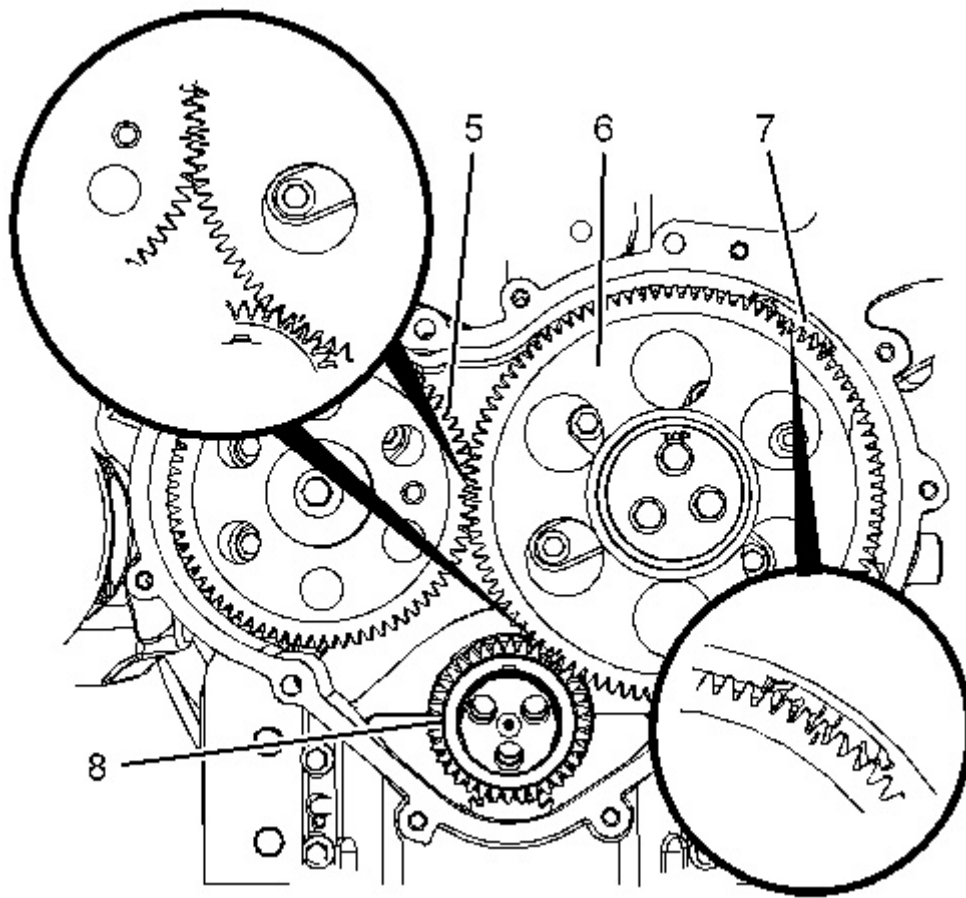

Illustration 4

g03707480

Alignment of timing marks

10. Mark gear (5), gear (6), gear (7) and gear (8) in order to show alignment. Refer to Illustration 4.

Note: Identification will ensure that the gears can be installed in the original alignment.

11. Remove camshaft gear (5). Refer to Disassembly and Assembly, "Camshaft Gear - Remove and Install" for the correct procedure.
12. Remove idler gear (6). Refer to Disassembly and Assembly, "Idler Gear - Remove and Install" for the correct procedure.

Installation Procedure

Table 2

| Required Tools | | | |
|----------------|-------------|--------------------------|-----|
| Tool | Part Number | Part Description | Qty |
| A | 9U-7336 | Housing | 1 |
| | 5P-7305 | Engine Turning Tool | 1 |
| B | 230-6284 | Timing Pin (Camshaft) | 1 |

| | | | |
|---|----------|-------------------------------------|---|
| C | 364-9107 | Timing Pin (Fuel Injection Pump) | 1 |
| D | 136-4632 | Timing Pin (Crankshaft) | 1 |
| | 268-1966 | Adapter | 1 |
| E | 298-5564 | T40 Torx Socket | 1 |
| F | 9U-7324 | Indicator Bracket | 1 |
| | 7H-1942 | Dial Indicator | 1 |
| | 3S-3268 | Indicator Contact Point | 1 |
| | 7H-1940 | Universal Attachment | 1 |

NOTICE

Keep all parts clean from contaminants.

Contaminants may cause rapid wear and shortened component life.

Note: The fuel injection pump must remain locked until the procedure instructs you to unlock the fuel injection pump.

1. Ensure that number one piston is at top dead center on the compression stroke. Refer to System Operation, Testing and Adjusting, "Finding Top Center Position for No.1 Piston" for the correct procedure.
-

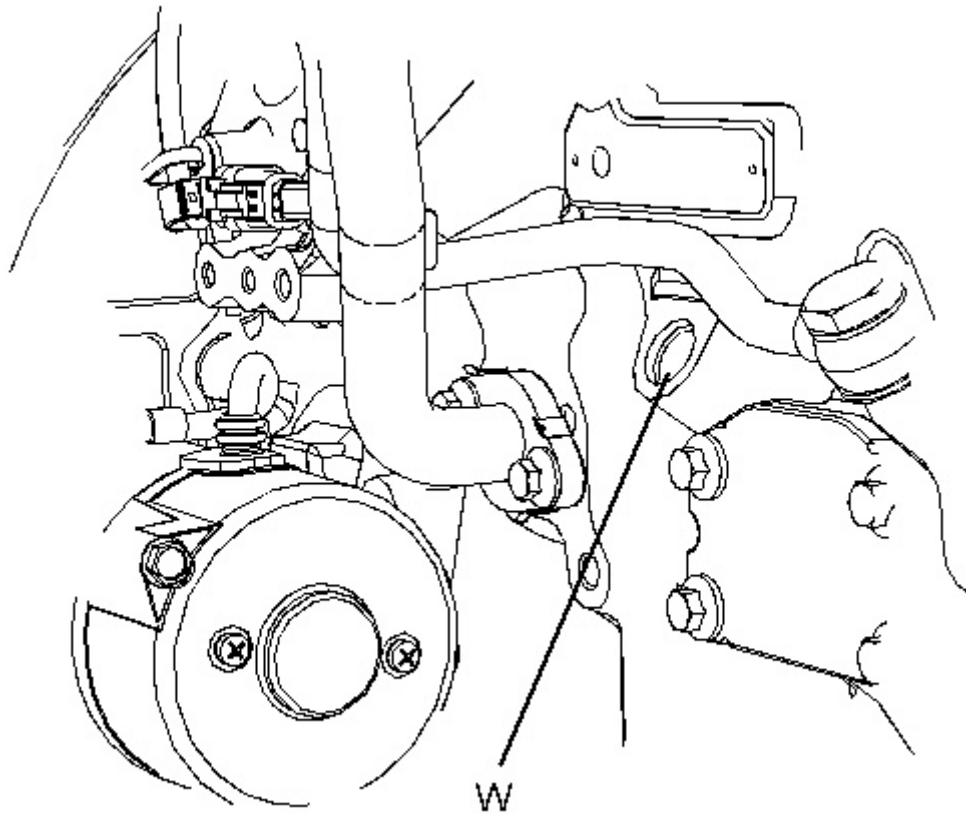

Illustration 5

g02485938

2. If necessary, install Tooling (D) into Hole (W) in the cylinder block. Use Tooling (D) in order to lock the crankshaft in the correct position. Refer to System Operation, Testing and Adjusting, "Finding Top Center Position for No.1 Piston" for the correct procedure.

Note: Do not use excessive force to install Tooling (D). Do not use Tooling (D) to hold the crankshaft during repairs.

3. Ensure that all of the components of the front gear group are clean and free from wear and damage. If necessary, replace any components that are worn or damaged.
-

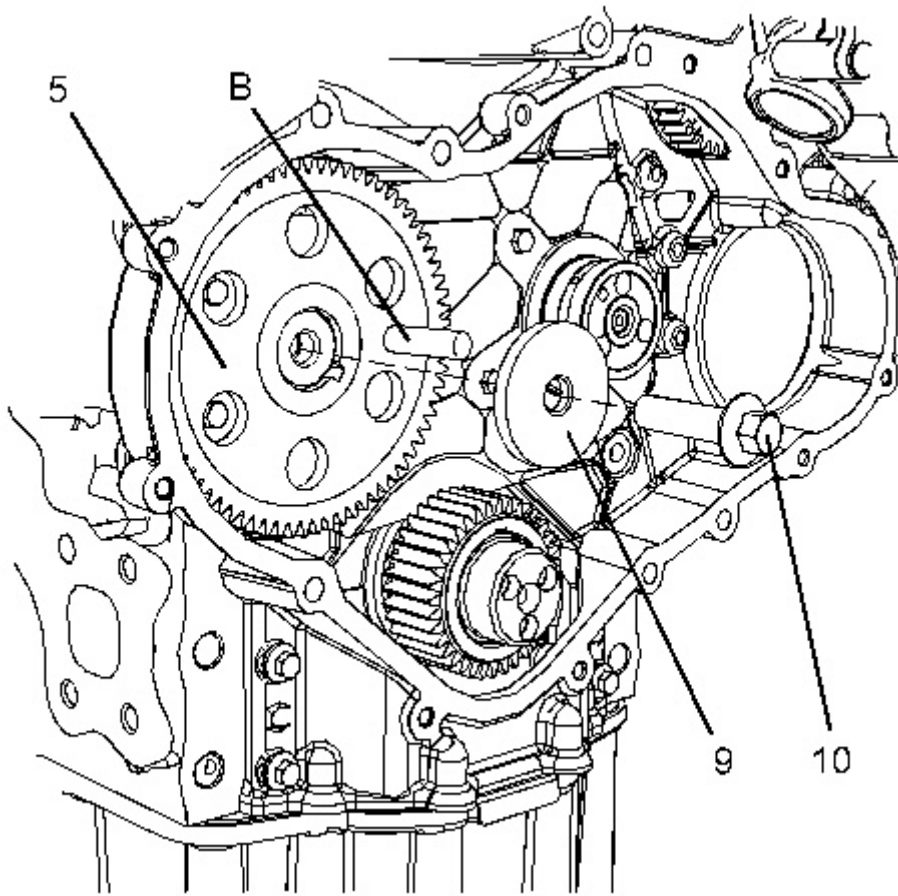

Illustration 6

g03707481

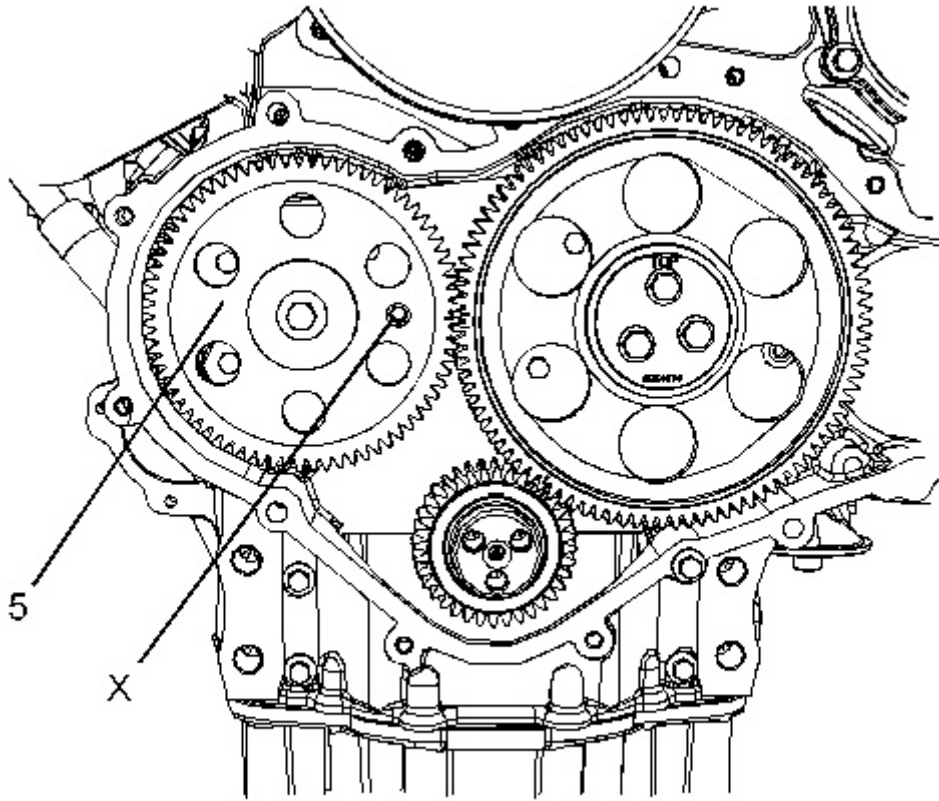

Illustration 7

g03707479

4. Install camshaft gear (5). Loosely install bolt (10) and washer (9) for the camshaft gear. Refer to Disassembly and Assembly, "Camshaft Gear - Remove and Install" for more information.
 5. Install Tooling (B) through Hole (X) in camshaft gear (5) into the front housing.
-

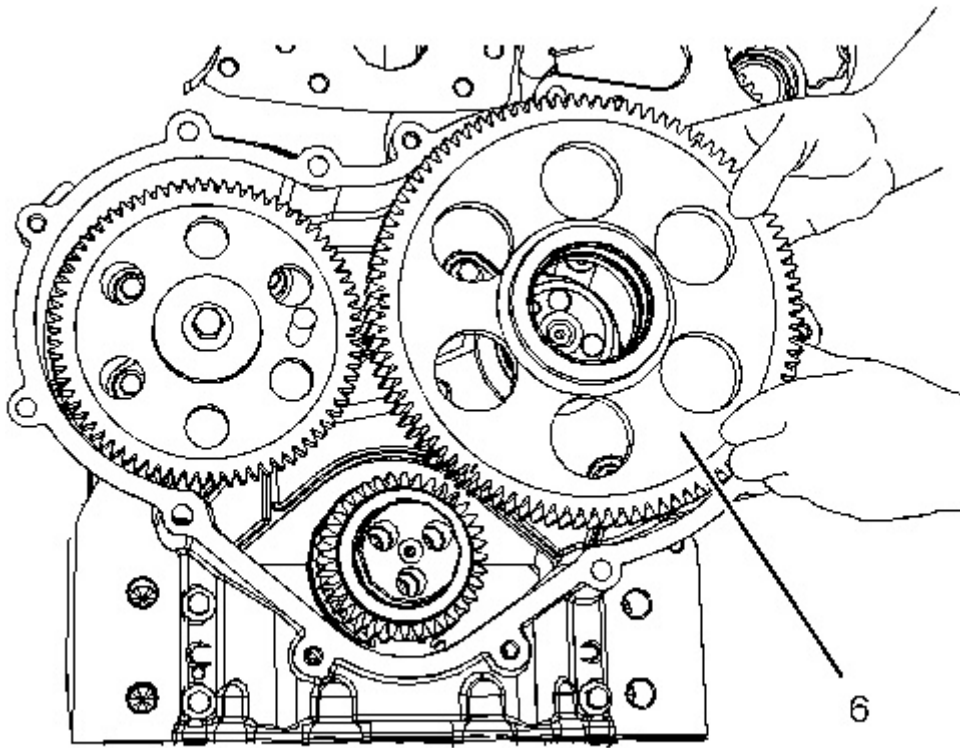

Illustration 8

g03707482

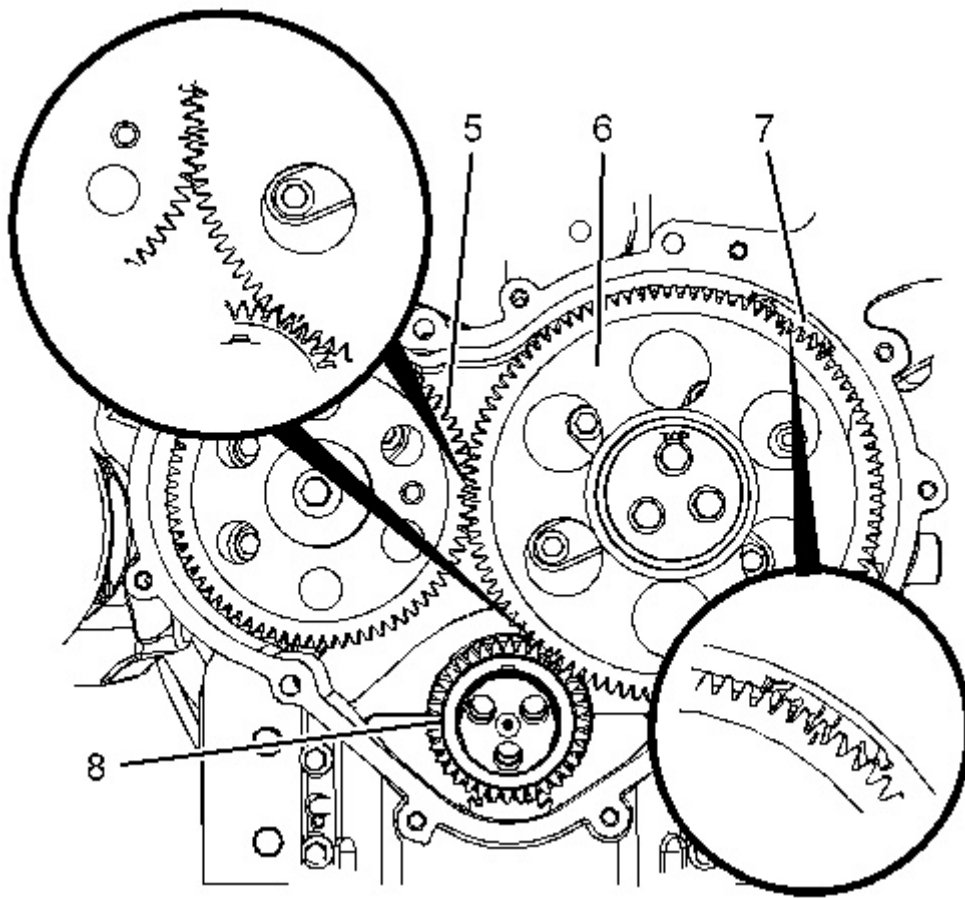

Illustration 9

g03707480

Alignment of timing marks

6. Install idler gear (6). Ensure that the timing marks on gear (5), gear (6), gear (7) and gear (8) are in alignment and that the mesh of the gears is correct. Refer to Disassembly and Assembly, "Idler Gear - Remove and Install" for the correct procedure.
 7. Use Tooling (F) in order to check the end play of the idler gear. Refer to Specifications, "Gear Group (Front)" and refer to Disassembly and Assembly, "Idler Gear - Remove and Install" for further information.
-

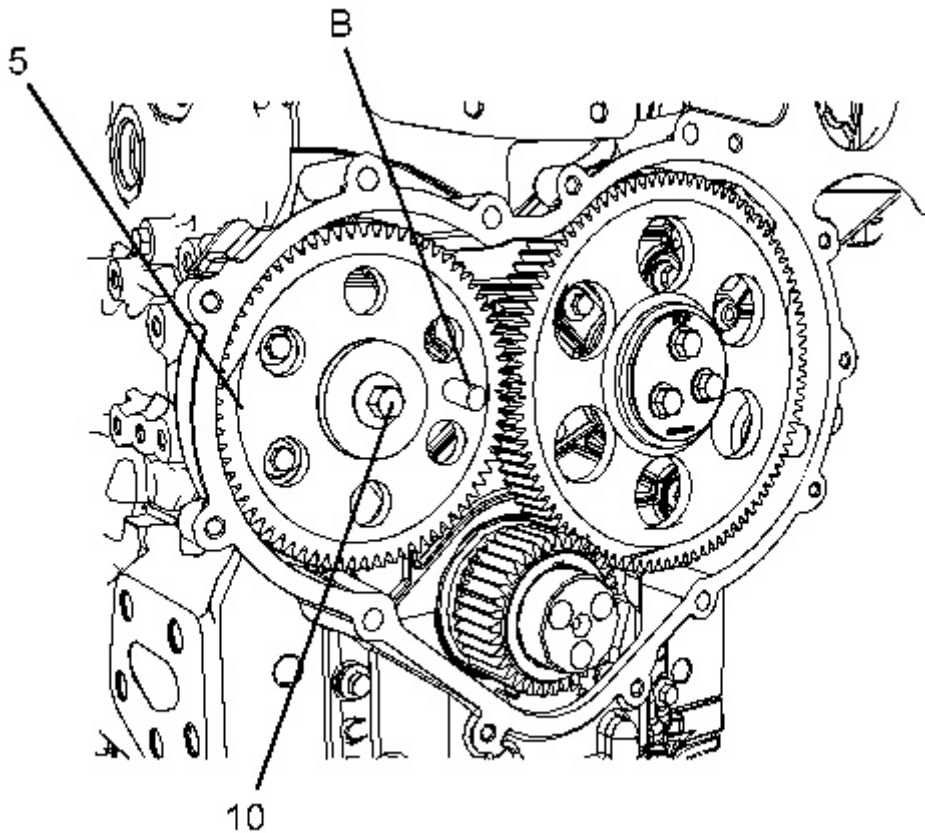

Illustration 10

g03707483

8. Ensure that the fuel injection pump is locked in the correct position. Refer to Disassembly and Assembly, "Fuel Injection Pump - Install" for the correct procedure.
9. Remove Tooling (B) and Tooling (C).
10. When bolt (10) is a 8.8 Grade. Tighten bolt (10) for camshaft gear (5) to a torque of 95 N·m (70 lb ft).

When bolt (10) is a 10.9 Grade. Tighten bolt (10) for camshaft gear (5) to a torque of 120 N·m (89 lb ft).

11. Use Tooling (F) in order to check the end play of the camshaft gear. Refer to Specifications, "Camshaft" for more information.
-

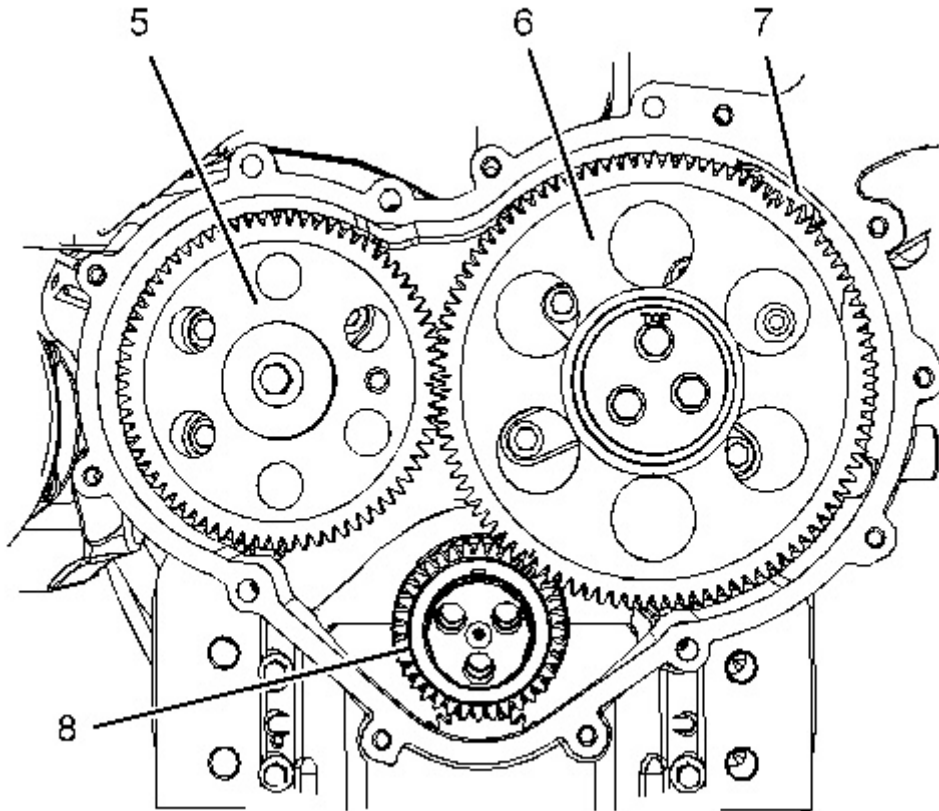

Illustration 11

g03707484

12. Use Tooling (F) in order to measure the backlash for gear (5), gear (6), gear (7) and gear (8). Refer to Specifications, "Gear Group (Front)" for further information.
13. Lubricate each gear with clean lubricating engine oil.
14. If necessary, use Tooling (A) in order to rotate the crankshaft so that number one piston is at top dead center on the compression stroke. Refer to System Operation, Testing and Adjusting, "Finding Top Center Position for No.1 Piston" for the correct procedure. If necessary, use Tooling (D) in order to lock the crankshaft so that number one piston is at top dead center on the compression stroke.
15. Remove Tooling (D).

NOTICE

Failure to ensure that the crankshaft is positioned at the safe position will result in interference between the pistons and the valves. Interference between the pistons and the valves will result in damage to the engine.

16. Use Tooling (A) in order to rotate the crankshaft in a clockwise direction and position the crankshaft at the safe position. Refer to System Operation, Testing and Adjusting, "Position the Valve Mechanism Before Maintenance Procedures" for the correct procedure.
-

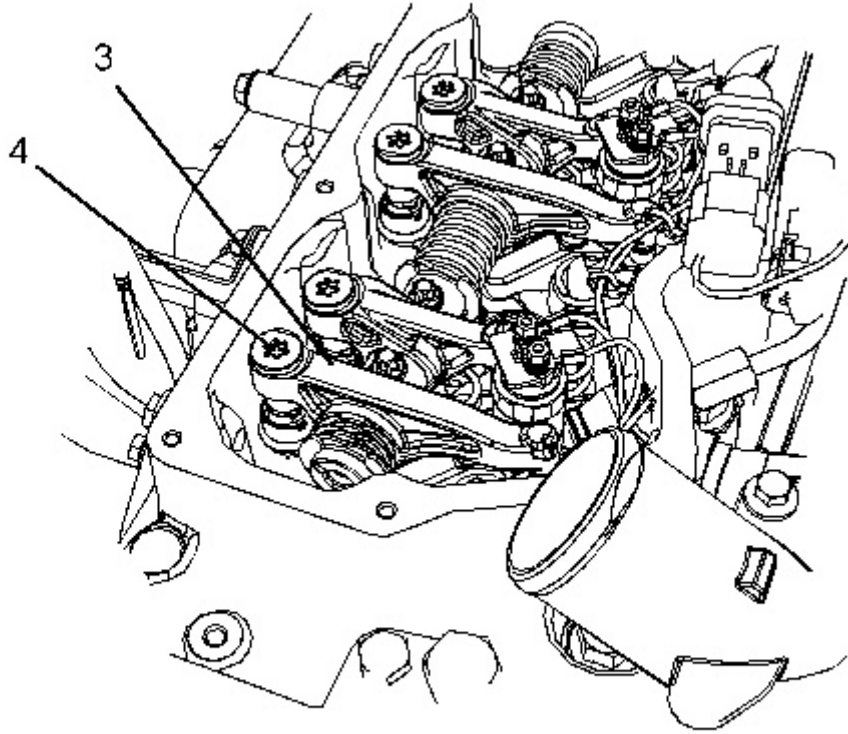

Illustration 12

g03707478

17. Use Tooling (E) in order to tighten threaded inserts (4) on all rocker arms (3). Tighten the threaded inserts to a torque of 30 N·m (265 lb in).

Note: When the threaded insert is tightened, the threaded insert must be correctly seated into the cup for the pushrod.

18. The engine should not be operated for a period 45 minutes after the threaded inserts on all the rocker arms have been tightened. This period of time will allow the force from the valve springs to purge off excessive engine oil from the hydraulic lifters.
-

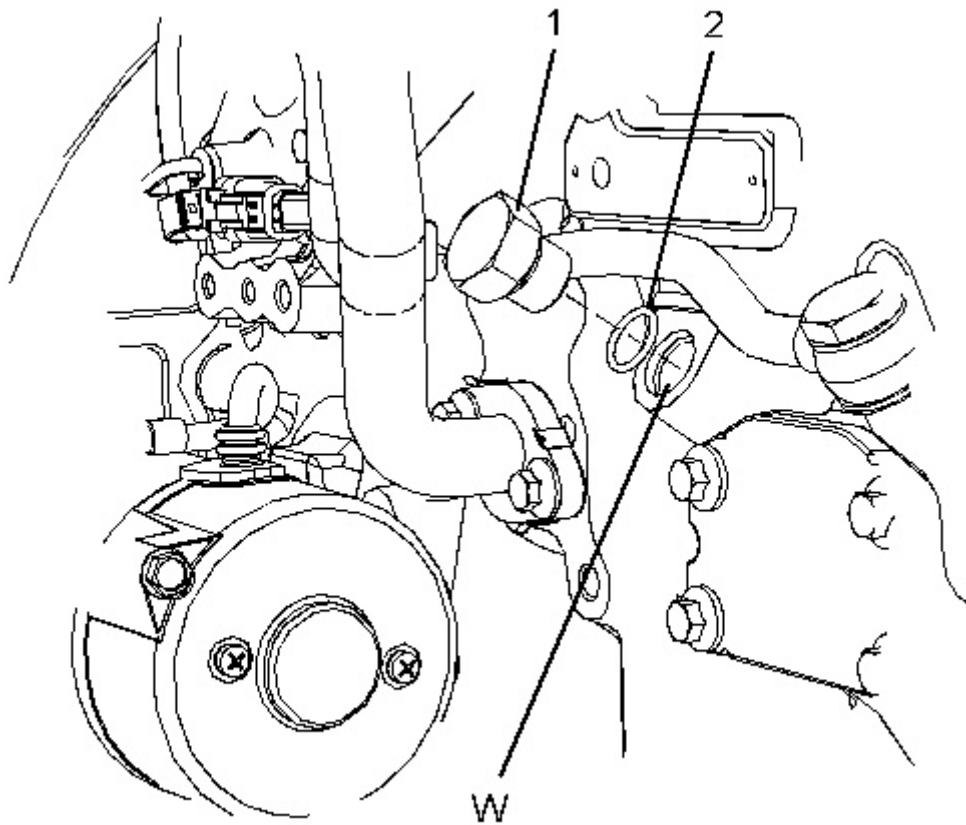

Illustration 13

g02485936

19. Install a new O-ring seal (1) to plug (2). Install the plug into Hole (W) in the cylinder block. Tighten plug (2) to a torque of 21 N·m (186 lb in).

End By:

- a. Install the front cover. Refer to Disassembly and Assembly, "Front Cover - Remove and Install" for the correct procedure.
 - b. Install the valve mechanism cover. Refer to Disassembly and Assembly, "Valve Mechanism Cover - Remove and Install" for the correct procedure.
-

Thank you so much for reading.
Please click the “Buy Now!”
button below to download the
complete manual.



After you pay.

You can download the most
perfect and complete manual in
the world immediately.

Our support email:

ebooklibonline@outlook.com