

Product: VIBRATORY COMPACTOR

Model: CS79B VIBRATORY COMPACTOR CM7

Configuration: CS78B, CS79B Vibratory Soil Compactor CM700001-UP (MACHINE) POWERED BY C7.1 Engine

Disassembly and Assembly

C7.1 Engines

Media Number -UENR0633-19

Publication Date -01/07/2015

Date Updated -29/10/2018

i05292388

Rear Power Take-Off (RPTO) - Install

SMCS - 1165-012-RE

Installation Procedure

Table 1

Required Tools			
Tool	Part Number	Part Description	Qty
A	1P-0520	Driver Group	1

NOTICE

Keep all parts clean from contaminants.

Contaminants may cause rapid wear and shortened component life.

1. Ensure that all components of the rear power take-off (RPTO) are clean and free from wear and damage.
-

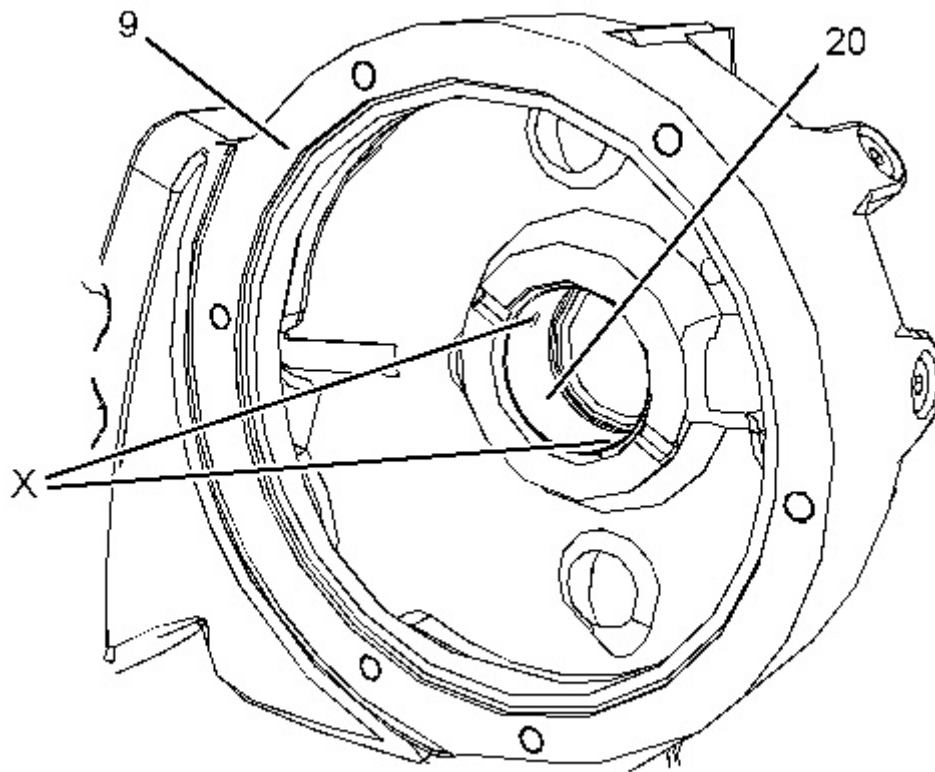

Illustration 1

g02070454

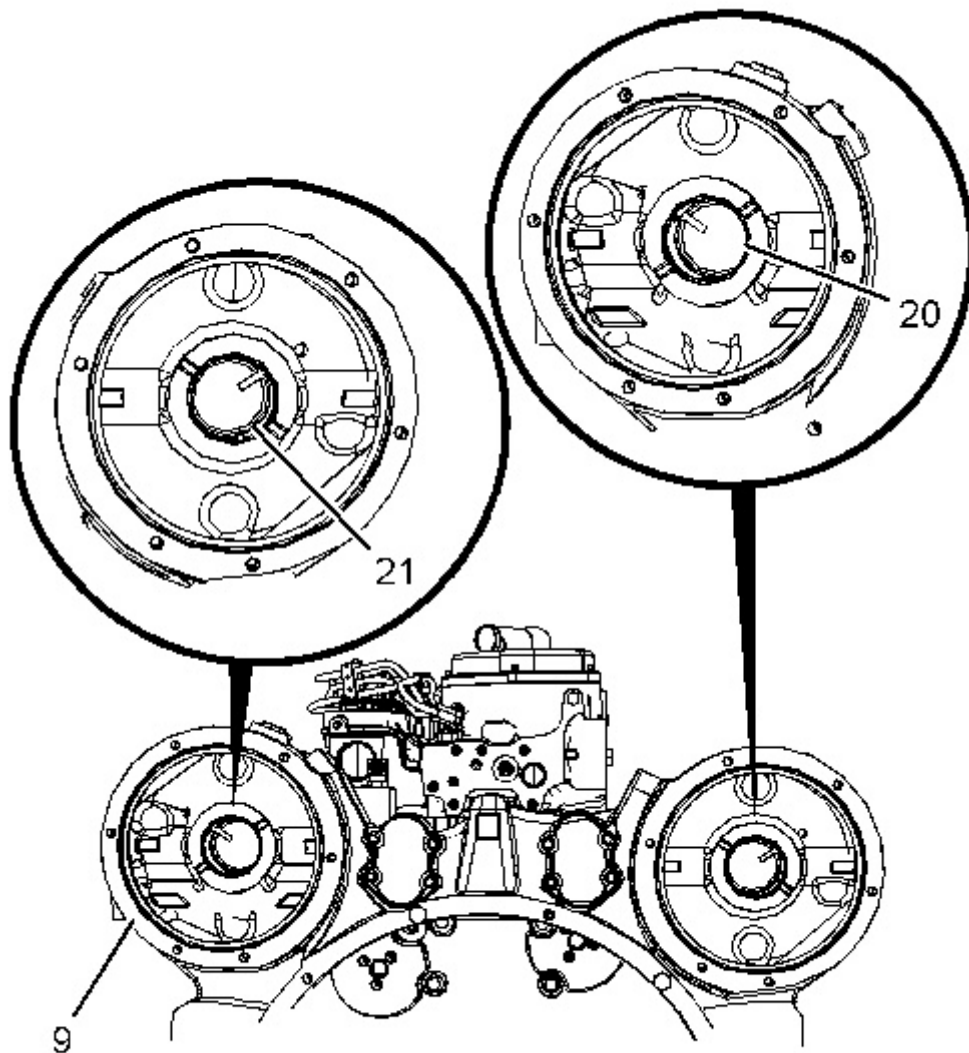

Illustration 2

g02069024

2. If necessary, follow Steps 2.a through Steps 2.c in order to install the sleeve bearing from the flywheel housing.
 - a. Accurately align oil Holes (X) in sleeve bearing (20) with the oil holes in flywheel housing (9).
 - b. Use Tooling (A) in order to install sleeve bearing (20) into flywheel housing (9).

Note: Ensure that the oil holes are correctly aligned. If the oil holes are not correctly aligned, the sleeve bearing should be removed.
 - c. Repeat Step 2.a through Steps 2.c in order to install sleeve bearing (21) to flywheel housing (9).
-

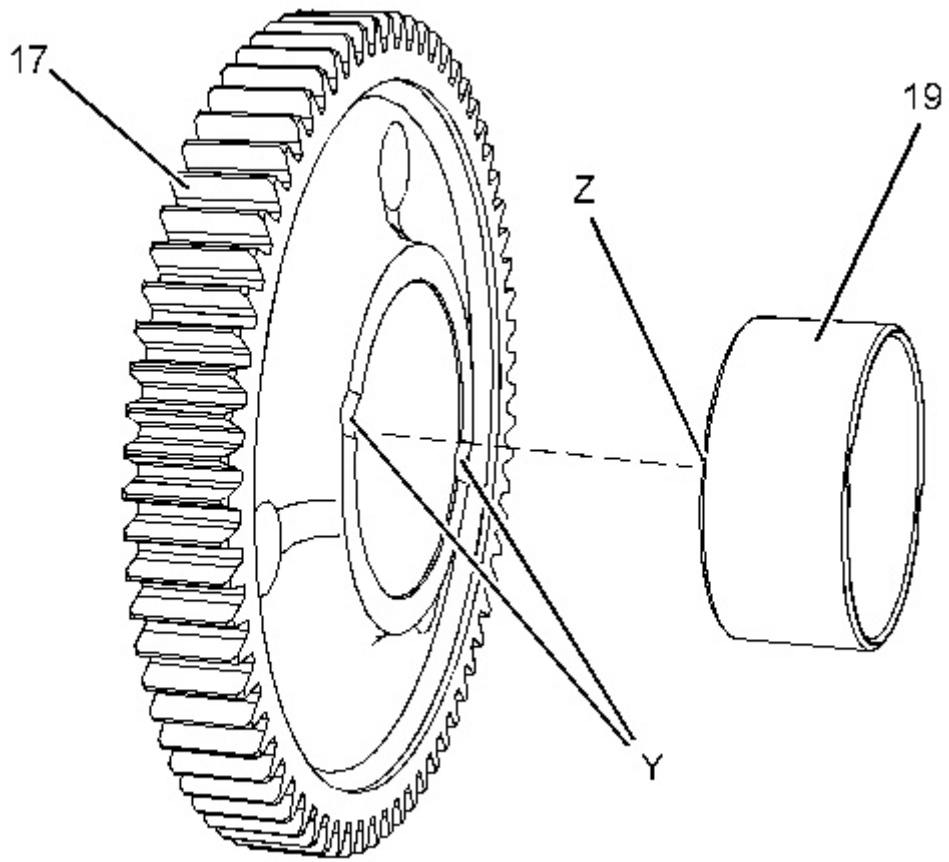

Illustration 3

g02070455

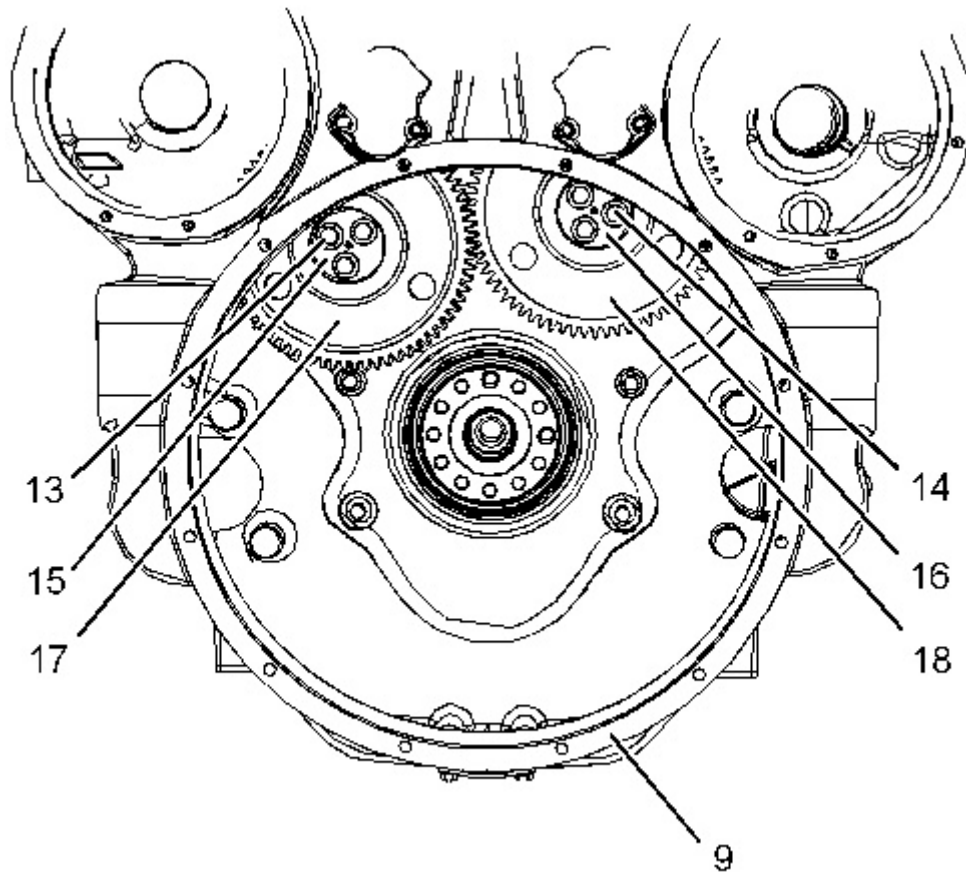

Illustration 4

g02069021

3. If necessary, follow Steps 3.a through Steps 3.d in order to install the sleeve bearing to the gears.
 - a. Place gear (17) onto suitable support.
 - b. Accurately align Grooves (Z) in sleeve bearing (20) with Grooves (Y) in gear (17).
 - c. Use Tooling (A) and a suitable press in order to install sleeve bearing (19) into gear (17).
 - d. Repeat Steps 3.a through Step 3.c in order to install the sleeve bearing to gear (18).
4. Lubricate idler hub (15) and gear (17) with clean oil. Install idler hub (15) to gear (17).

Note: Ensure that the gear and the idler hub are correctly oriented.
5. Install gear (17) and idler hub (15) assembly to flywheel housing (9).

Note: Ensure that the oil hole in the idler hub is correctly positioned.
6. Install bolts (13) to idler hub (15) and hand tighten bolts.

Note: Ensure that the idler hub is correctly aligned to the flywheel housing.
7. Repeat Steps 4 through Step 6 in order to install gear (18), idler hub (16) and bolts (14) to flywheel housing (9).

8. Tighten bolts (13) and bolts (14) to a torque of 100 N·m (74 lb ft).
 9. Ensure that there is tactile backlash between gear (17) and gear (18). Ensure that there is end play between the idler hubs and the gears.
-

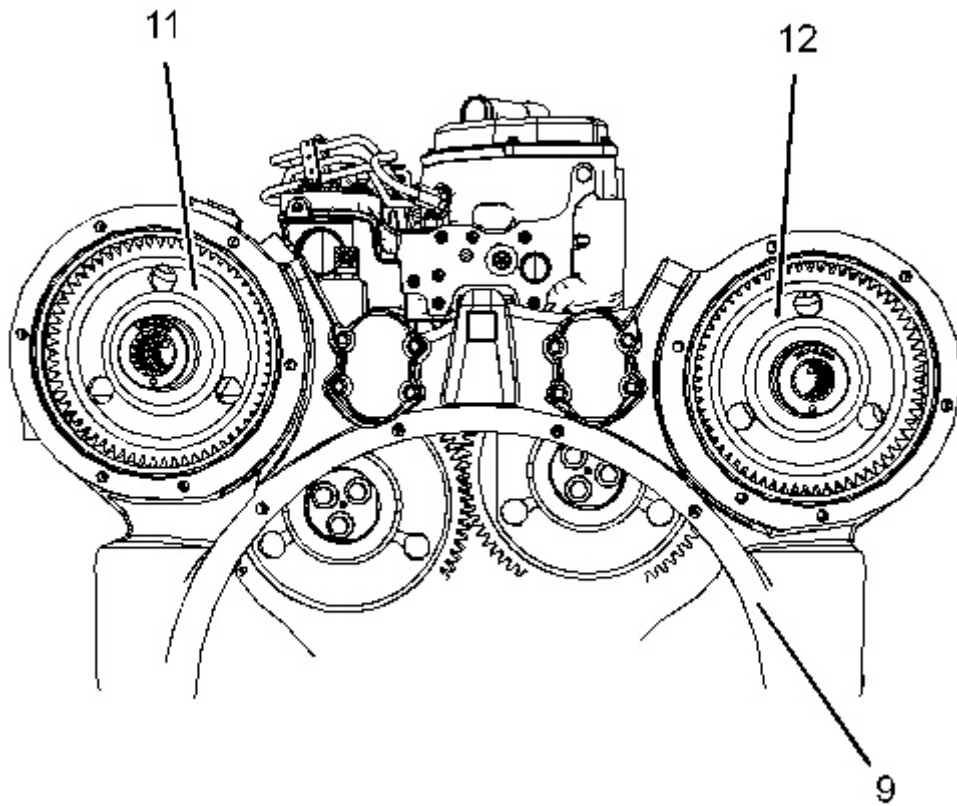

Illustration 5

g02069020

10. install gear assembly (11) and gear assembly (12) to flywheel housing (9).
-

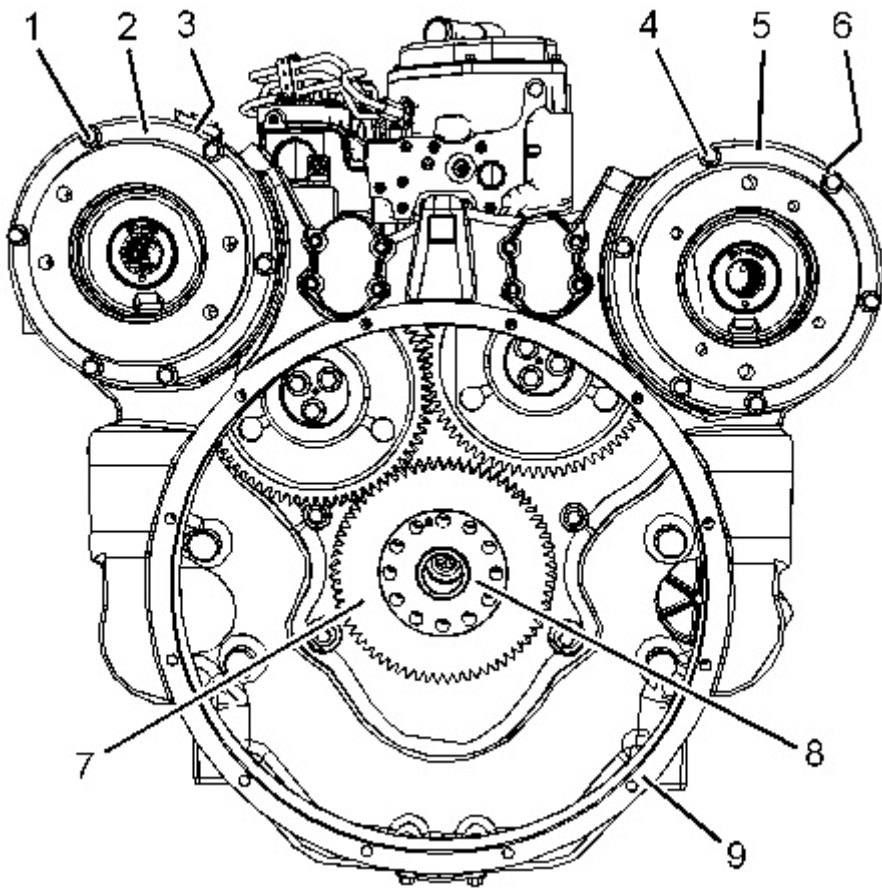

Illustration 6

g02069019

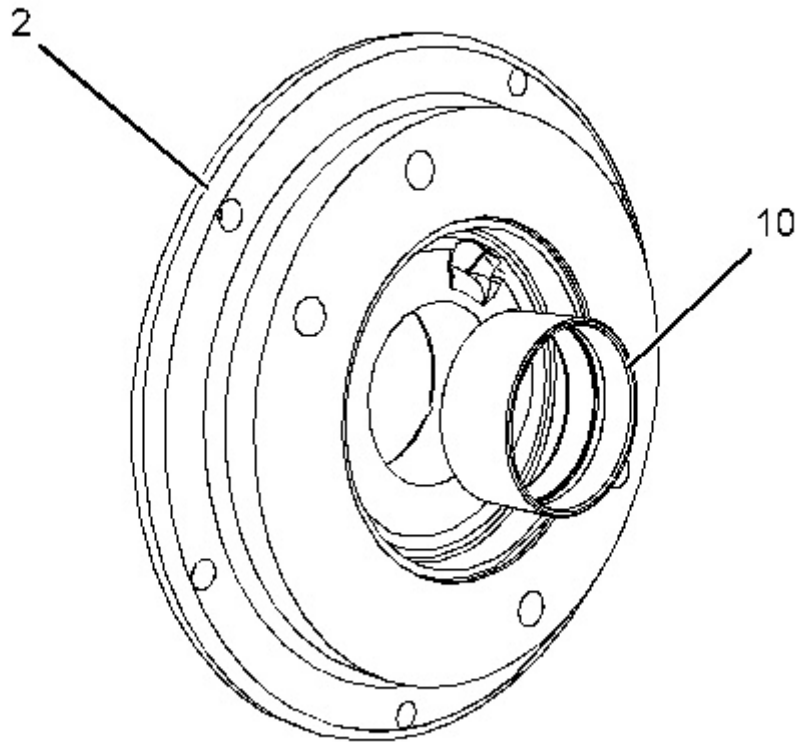

Illustration 7

g02070473

11. If necessary, follow Steps 11.a through Steps 11.c in order to install the sleeve bearing to the adapter.
 - a. Place adapter (2) onto suitable support.
 - b. Use Tooling (A) and a suitable press in order to install sleeve bearing (10) into adapter (2).
 - c. Repeat Steps 11.a through Step 11.b in order to install the sleeve bearing into adapter (5).
12. Install a new O-ring seal (3) (not shown) to adapter (2).
13. Install adapter (2) to flywheel housing (9).

Note: Ensure correct orientation of the adapter.
14. Install bolts (1) and tighten the bolts to a torque of 55 N·m (41 lb ft).
15. Install a new O-ring seal (6) (not shown) to adapter (5).
16. Install adapter (5) to flywheel housing (9).

Note: Ensure correct orientation of the adapter.
17. Install bolts (4) and tighten the bolts to a torque of 55 N·m (41 lb ft).

18. Ensure that there is tactile backlash between the gears. Ensure that there is end play between the gears and the flywheel housing and the adapters.
19. Install gear (7) to crankshaft (8).
20. If necessary, install the OEM equipment to the rear power take-off (RPTO).

End By:

- a. Install the flywheel. Refer to Disassembly and Assembly, "Flywheel - Install" for the correct procedure.
-

Product: VIBRATORY COMPACTOR

Model: CS79B VIBRATORY COMPACTOR CM7

Configuration: CS78B, CS79B Vibratory Soil Compactor CM700001-UP (MACHINE) POWERED BY C7.1 Engine

Disassembly and Assembly

C7.1 Engines

Media Number -UENR0633-19

Publication Date -01/07/2015

Date Updated -29/10/2018

i05909481

Vibration Damper and Pulley - Remove

SMCS - 1205-011

Removal Procedure

Table 1

Required Tools			
Tool	Part Number	Part Description	Qty
A	-	Guide Stud M14 x 1.5 by 100 mm	1
B	227-4393	E18 Torx Socket	1

Start By:

- A. Remove the alternator belt. Refer to Disassembly and Assembly, "Alternator Belt - Remove and Install" for the correct procedure.

Note: The weight of the assembly of the crankshaft pulley, the vibration damper, and the crankshaft adapter is approximately 22 kg (48 lb).

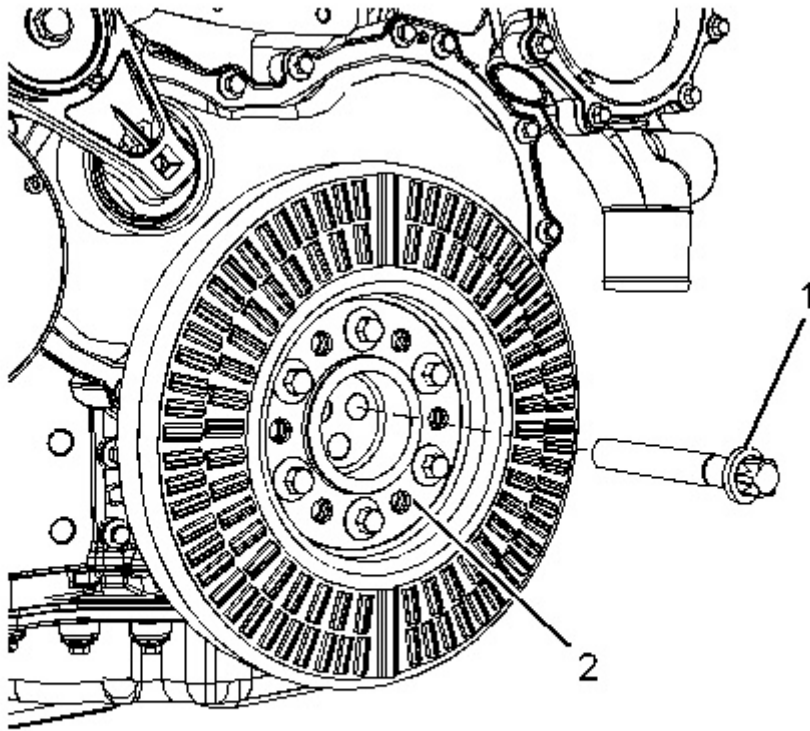

Illustration 1

g02368017

1. Use a suitable tool in order to prevent the crankshaft from rotating. Use Tooling (B) to remove one Torx screws (1) from crankshaft pulley assembly (2) .
 2. Install Tooling (A) into crankshaft pulley assembly (2) .
 3. Remove remaining Torx screws (1) from crankshaft pulley assembly (2) .
 4. Remove crankshaft pulley assembly (2) .
 5. Remove Tooling (A) .
-

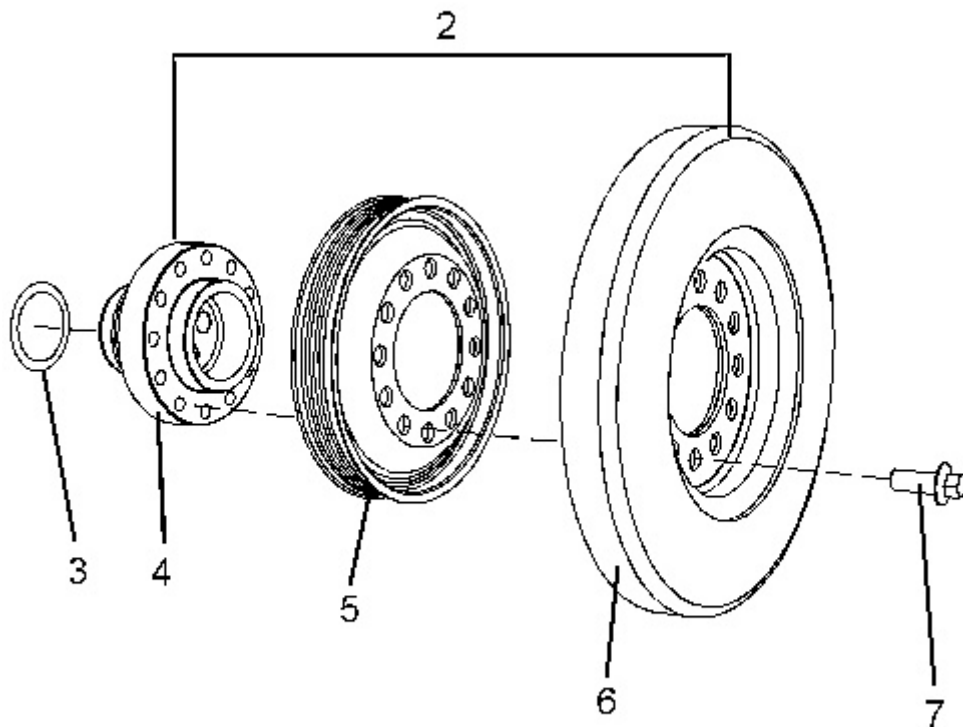

Illustration 2

g02368018

6. If necessary, follow Step 6.a through Step 6.b in order to remove friction shim (3) from the crankshaft.
 - a. Remove the front seal from the front cover. Refer to Disassembly and Assembly, "Crankshaft Front Seal - Remove and Install" for the correct procedure.
 - b. Remove friction shim (3).
 7. If necessary, follow Step 7.a through Step 7.c in order to disassemble vibration damper, crankshaft pulley from crankshaft adapter.
 - a. Place the crankshaft pulley assembly onto a suitable support.
 - b. Remove bolts (7) from crankshaft pulley assembly (2).
 - c. Remove vibration damper (6) and crankshaft pulley (5) from adapter (4).
-

Product: VIBRATORY COMPACTOR

Model: CS79B VIBRATORY COMPACTOR CM7

Configuration: CS78B, CS79B Vibratory Soil Compactor CM700001-UP (MACHINE) POWERED BY C7.1 Engine

Disassembly and Assembly

C7.1 Engines

Media Number -UENR0633-19

Publication Date -01/07/2015

Date Updated -29/10/2018

i05909490

Vibration Damper and Pulley - Install

SMCS - 1205-012

Installation Procedure

Table 1

Required Tools			
Tool	Part Number	Part Description	Qty
A	-	Guide Stud M14 x 1.5 by 100 mm	1
B	227-4393	E18 Torx Socket	1
C	8T-3052	Degree Wheel	1
D	-	Guide Studs M12 x 1.75 by 50 mm	2

NOTICE

Keep all parts clean from contaminants.

Contaminants may cause rapid wear and shortened component life.

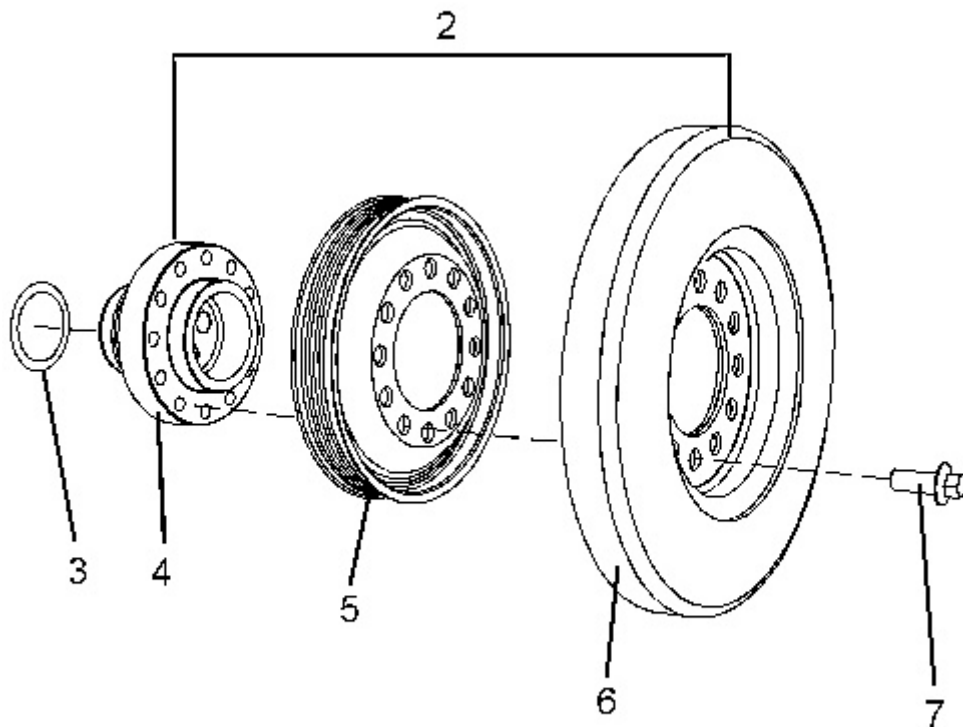

Illustration 1

g02368018

1. Ensure that the crankshaft adapter and the front of the crankshaft are clean and free from damage.
2. Inspect vibration damper (6) for damage. If necessary, replace the vibration damper.
3. If necessary, follow Step 3.a through Step 3.e in order to install vibration damper, crankshaft pulley to crankshaft adapter.
 - a. Place crankshaft adapter (4) onto a suitable support.
 - b. Install Tooling (D) crankshaft adapter (4) .
 - c. Install crankshaft pulley (5) and vibration damper (6) over Tooling (D) .
 - d. Install bolts (7) to the crankshaft pulley assembly.

Note: Evenly space bolts (7) around the crankshaft pulley assembly.
 - e. Tighten bolts (7) to a torque of 115 N·m (85 lb ft).
4. If necessary, install friction shim (3) . Follow Step 4.a through Step 4.b in order to install friction shim (3) .
 - a. Install friction shim (3) .

- b. Install a new front seal to the front cover. Refer to Disassembly and Assembly, "Crankshaft Front Seal - Remove and Install" for the correct procedure.

5. Install Tooling (A) to the crankshaft.

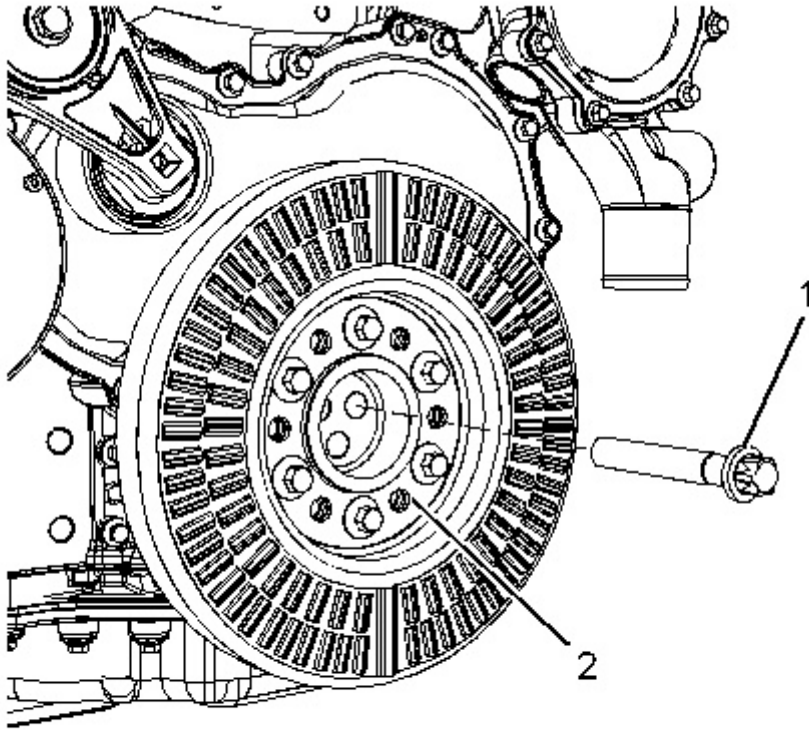

Illustration 2

g02368017

6. Install crankshaft pulley assembly (2) onto the crankshaft.
7. Install one Torx screws (1) to crankshaft pulley assembly (2) hand tighten.
8. Remove Tooling (A) .
9. Install remaining Torx screws (1) to crankshaft pulley assembly (2) .
10. Use a suitable tool in order to prevent the crankshaft from rotating. Tighten Torx screws (1) to a torque of 40 N·m (29 lb ft).
11. Use Tooling (B) and Tooling (C) to turn Torx screws (1) through an additional 120 degrees.

End By: Install the alternator belt. Refer to Disassembly and Assembly, "Alternator Belt - Remove and Install" for the correct procedure.

Product: VIBRATORY COMPACTOR

Model: CS79B VIBRATORY COMPACTOR CM7

Configuration: CS78B, CS79B Vibratory Soil Compactor CM700001-UP (MACHINE) POWERED BY C7.1 Engine

Disassembly and Assembly

C7.1 Engines

Media Number -UENR0633-19

Publication Date -01/07/2015

Date Updated -29/10/2018

i05292118

Crankshaft Front Seal - Remove and Install - Crankshaft Front Seal for Heavy Duty Front Cover

SMCS - 1160-010

Removal Procedure

Table 1

Required Tools			
Tool	Part Number	Part Description	Qty
A	278-2636	Front Oil Seal Removal Tool	1

Start By:

- Remove the crankshaft pulley. Refer to Disassembly and Assembly, "Vibration Damper and Pulley - Remove" for the correct procedure.

NOTICE

Keep all parts clean from contaminants.

Contaminants may cause rapid wear and shortened component life.

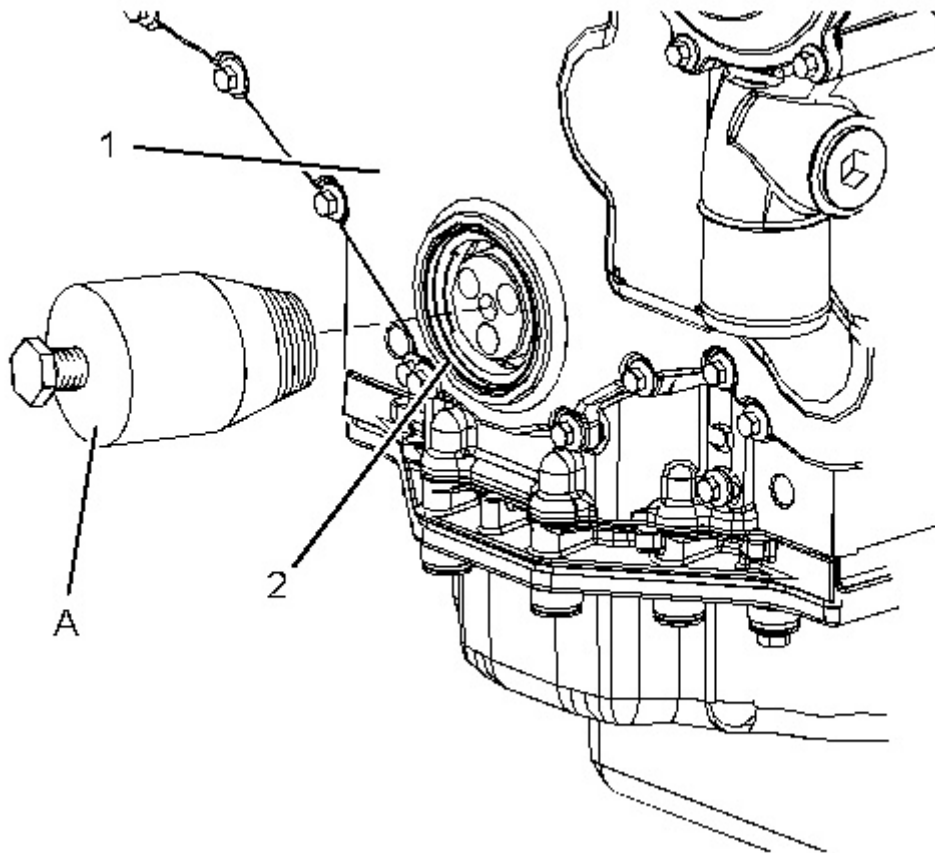

Illustration 1

g02048634

1. Position Tooling (A) on the nose of the crankshaft. Screw Tooling (A) into crankshaft front seal (2).

Note: Do not damage the edge of the front cover for the crankshaft front seal.

2. Screw the bolt into Tooling (A) in order to remove crankshaft front seal (2) from front cover (1).

Installation Procedure

Table 2

Required Tools			
Tool	Part Number	Part Description	Qty
B	9U-6206	Stud Front Seal Installer	1
	9U-6207	Plate	1
	9U-6209	Sleeve Plate	1
	9U-6211	Seal Installer Tool	1
	366-5984	Installer Assembly	

NOTICE

Keep all parts clean from contaminants.

Contaminants may cause rapid wear and shortened component life.

1. Ensure that the bore for the crankshaft front oil seal in the front cover is clean and free from damage.
-

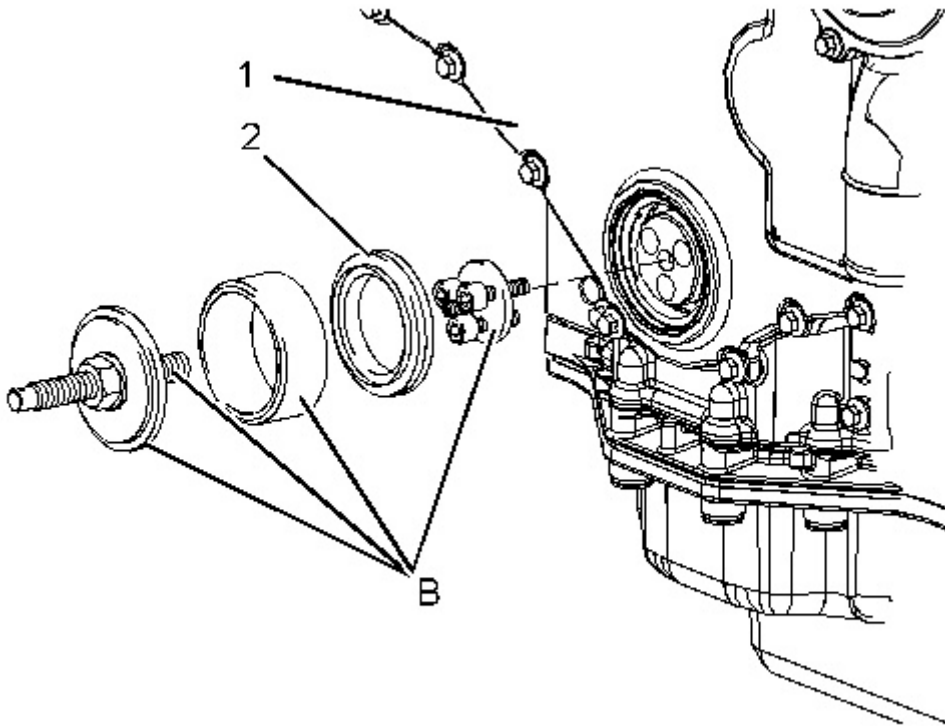

Illustration 2

g03413520

2. Assemble Tooling (B).
3. Correctly position a new crankshaft front seal (2) to front cover (1).

Note: If the crankshaft front seal is supplied with a sleeve, remove the sleeve from the crankshaft front seal before installation.

4. Use Tooling (B) to install crankshaft front seal (2) to front cover (1). Ensure that the front face of the crankshaft front seal is installed to a depth of 6.5 ± 0.2 mm (0.256 ± 0.008 inch).
5. Remove Tooling (B) from the crankshaft.

End By:

- a. Install the crankshaft pulley. Refer to Disassembly and Assembly, "Vibration Damper and Pulley - Install" for the correct procedure.
-

Product: VIBRATORY COMPACTOR

Model: CS79B VIBRATORY COMPACTOR CM7

Configuration: CS78B, CS79B Vibratory Soil Compactor CM700001-UP (MACHINE) POWERED BY C7.1 Engine

Disassembly and Assembly

C7.1 Engines

Media Number -UENR0633-19

Publication Date -01/07/2015

Date Updated -29/10/2018

i05292119

Crankshaft Front Seal - Remove and Install

SMCS - 1160-010

Removal Procedure

Table 1

Required Tools			
Tool	Part Number	Part Description	Qty
A	278-2636	Front Oil Seal Removal Tool	1

Start By:

- a. Remove the crankshaft pulley. Refer to Disassembly and Assembly, "Crankshaft Pulley - Remove and Install".

NOTICE

Keep all parts clean from contaminants.

Contaminants may cause rapid wear and shortened component life.

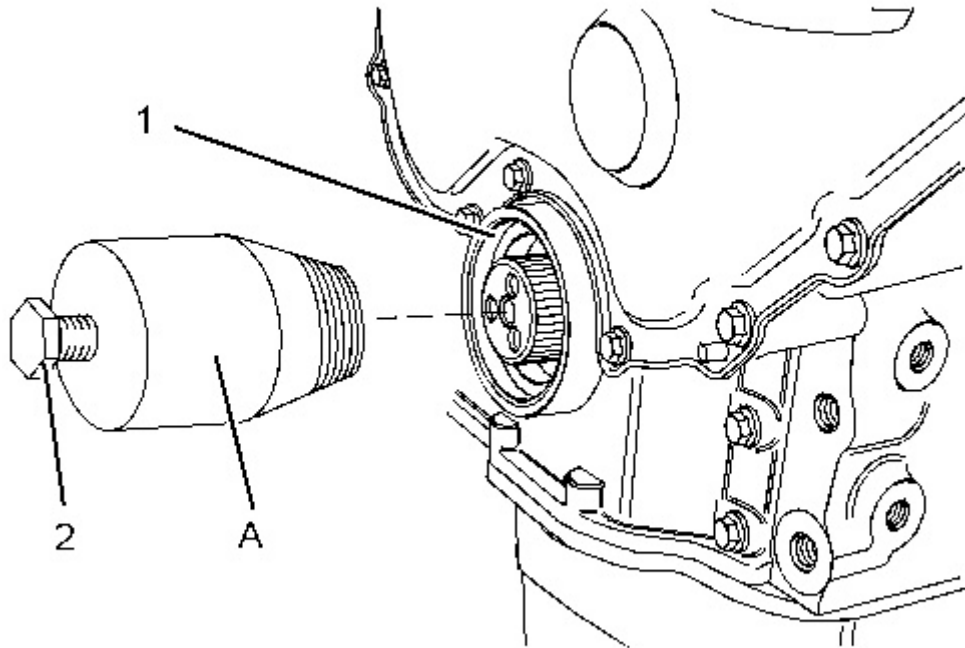

Illustration 1

g03429500

1. Position Tooling (A) on the nose of the crankshaft. Screw Tooling (A) into crankshaft front seal (1).

Note: Do not damage the edge of the housing for the crankshaft front seal.

2. Screw bolt (2) into Tooling (A) in order to remove crankshaft front seal (1).

Installation Procedure

Table 2

Required Tools			
Tool	Part Number	Part Description	Qty
B	9U-6206	Stud Front Seal Installer	1
	9U-6207	Plate	1
	9U-6209	Sleeve Plate	1
	9U-6211	Seal Installer Tool	1
	366-5984	Installer Assembly	

Thank you so much for reading.
Please click the “Buy Now!”
button below to download the
complete manual.



After you pay.

You can download the most
perfect and complete manual in
the world immediately.

Our support email:

ebooklibonline@outlook.com