

Product: TRACK-TYPE TRACTOR

Model: D3K2 XL TRACK-TYPE TRACTOR KF2

Configuration: D3K2 XL & D3K2 LGP Small Track Type Tractor KF200001-UP (MACHINE) POWERED BY C4.4 Engine

Disassembly and Assembly

C4.4 Engines for Caterpillar Built Machines

Media Number -UENR4516-11

Publication Date -01/06/2015

Date Updated -29/10/2018

i05820290

Idler Gear - Remove

SMCS - 1206-011

Removal Procedure

Table 1

Required Tools			
Tool	Part Number	Part Description	Qty
A	9U-7336	Housing	1
	5P-7306	Engine Turning Tool	1
B	364-9107	Timing Pin (Fuel Injection Pump)	1
C	230-6284	Timing Pin (Camshaft)	1
D	136-4632	Timing Pin (Crankshaft)	1
	268-1966	Adapter	1
E	298-5564	T40 Torx Socket	1

Start By:

- a. Remove the front cover. Refer to Disassembly and Assembly, "Front Cover - Remove and Install" for the correct procedure.
- b. Remove the valve mechanism cover. Refer to Disassembly and Assembly, "Valve Mechanism Cover - Remove and Install" for the correct procedure.

Note: Care must be taken in order to ensure that the fuel injection pump timing is not lost during the removal of the fuel pump gear. Carefully follow the procedure in order to remove the fuel pump gear.

NOTICE

Keep all parts clean from contaminants.

Contaminants may cause rapid wear and shortened component life.

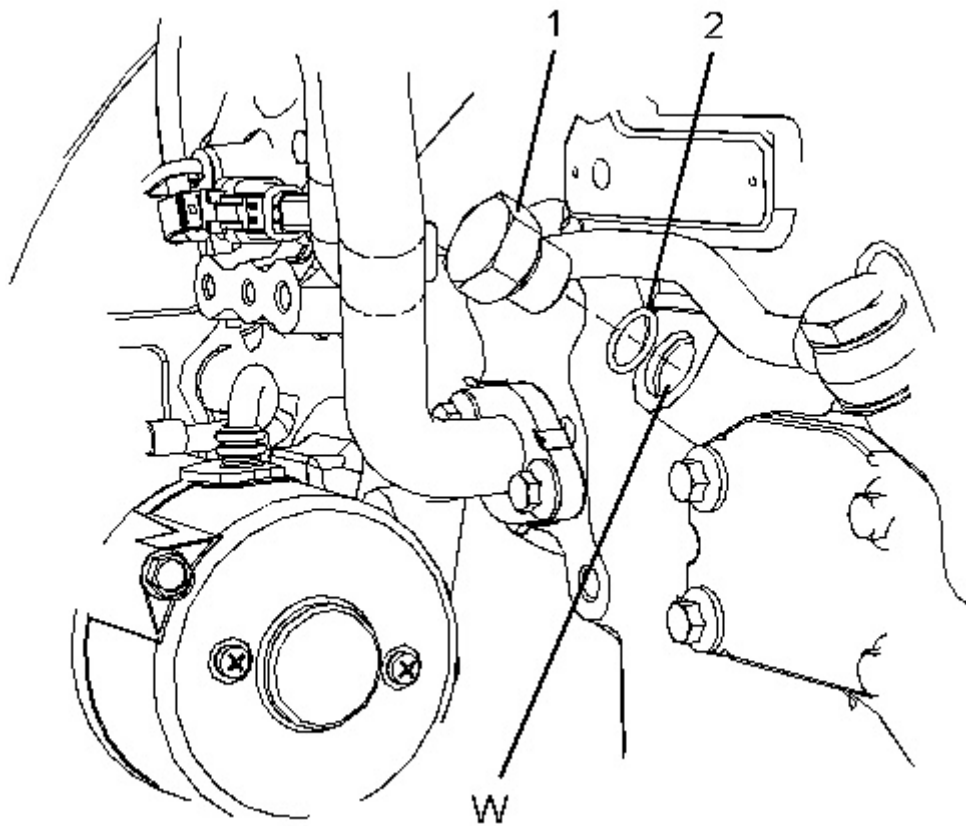

Illustration 1

g02485936

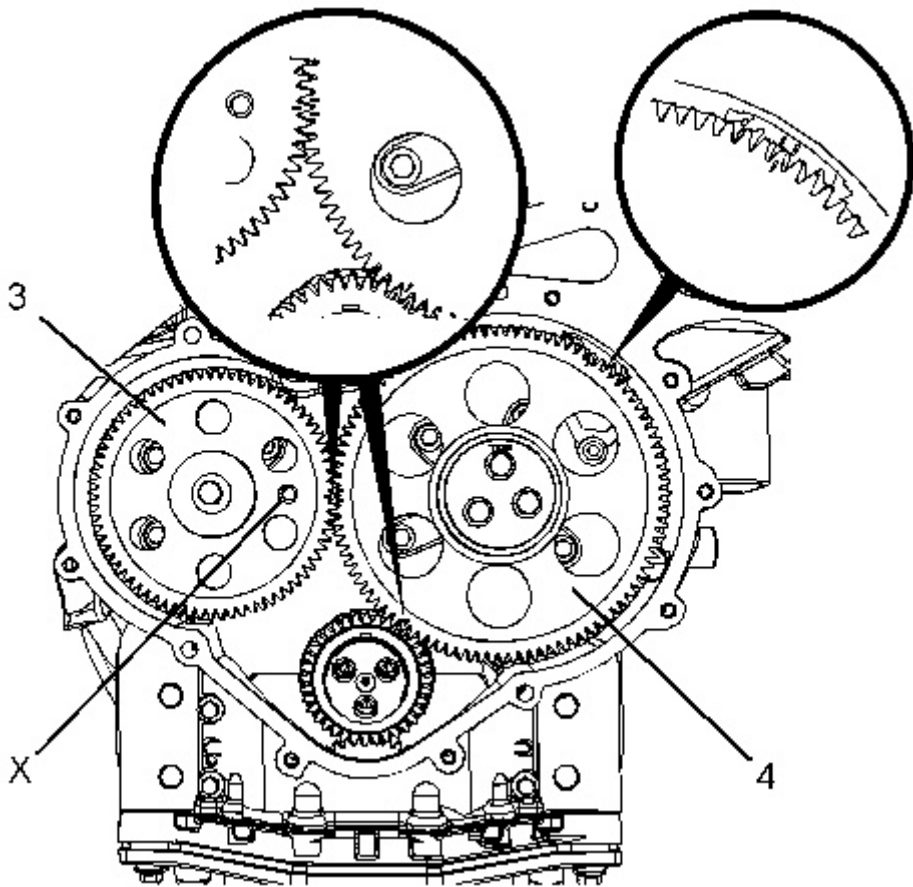

Illustration 2

g01994553

1. Remove plug (1) from the cylinder block and remove O-ring seal (2) from the plug.
2. Use Tooling (A) in order to rotate the crankshaft so that number one piston is at top dead center on the compression stroke. Refer to System Operation, Testing and Adjusting, "Finding Top Center Position for No.1 Piston" for the correct procedure.
3. Install Tooling (D) through Hole (W) in order to lock the crankshaft so that number one piston is at top dead center on the compression stroke.
4. Ensure that Tooling (C) is installed into Hole (X) in camshaft gear (3). Use Tooling (C) in order to lock the camshaft in the correct Position.

Note: Ensure that the gears are marked in order to show alignment. Refer to Illustration 2.

5. Use Tooling (B) in order to lock the fuel injection pump gear in the correct position. Refer to Disassembly and Assembly, "Fuel Injection Pump - Remove" for the correct procedure.
-

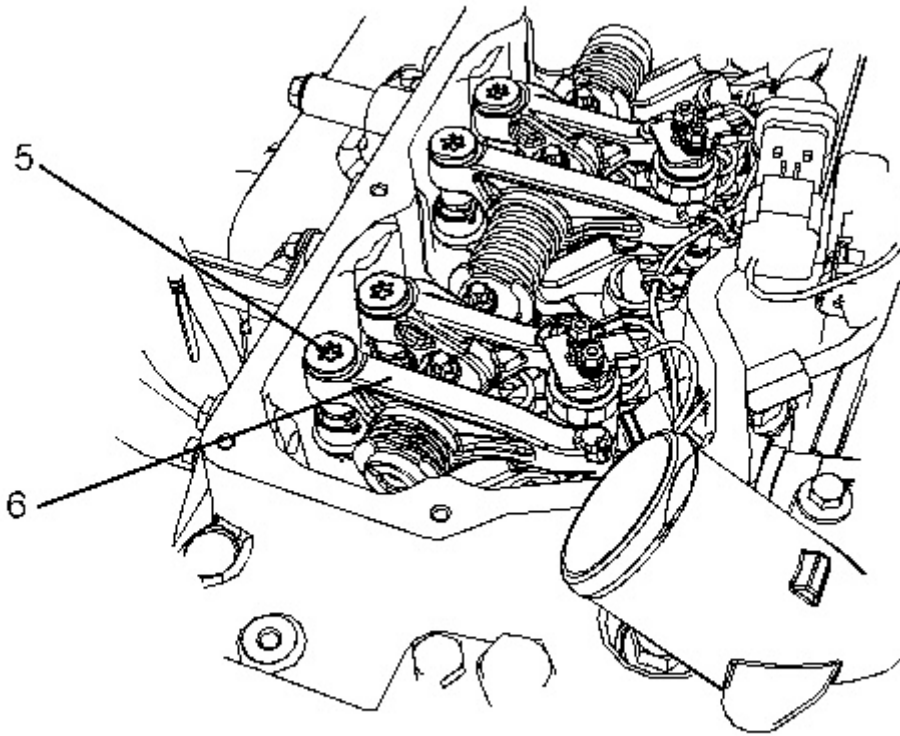

Illustration 3

g01994556

6. Use Tooling (E) in order to loosen threaded inserts (5) on all rocker arms (6). Unscrew threaded inserts (5) on all rocker arms (6) until all valves are fully closed.

Note: Failure to ensure that ALL threaded inserts are fully unscrewed can result in contact between the valves and pistons.

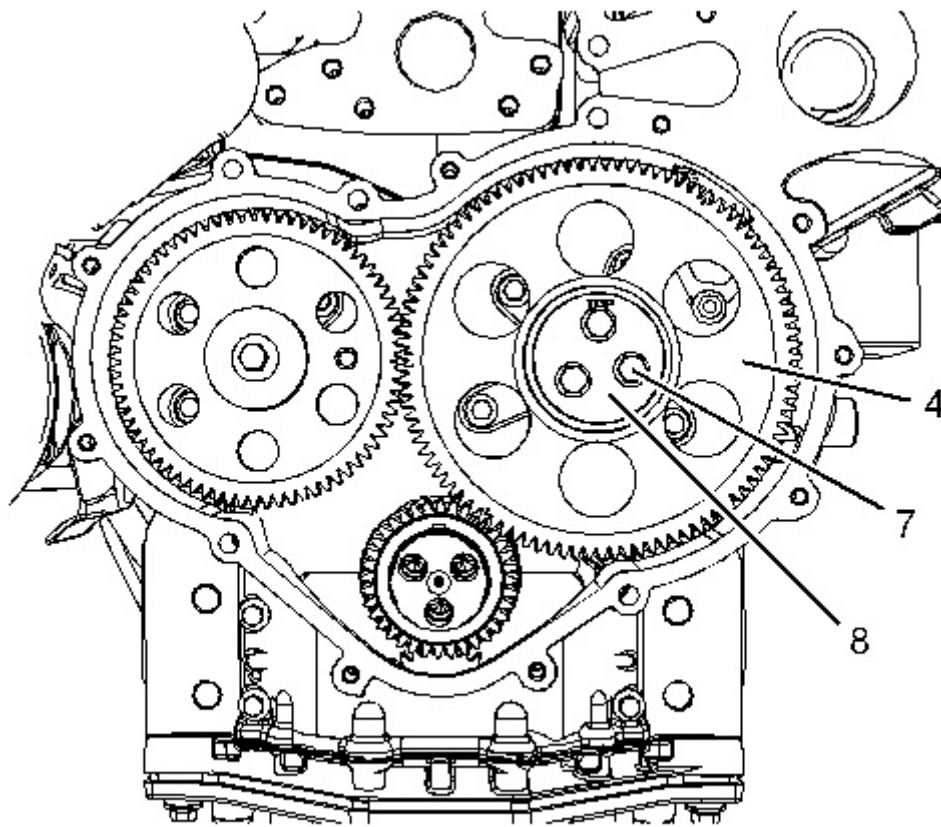

Illustration 4

g01994576

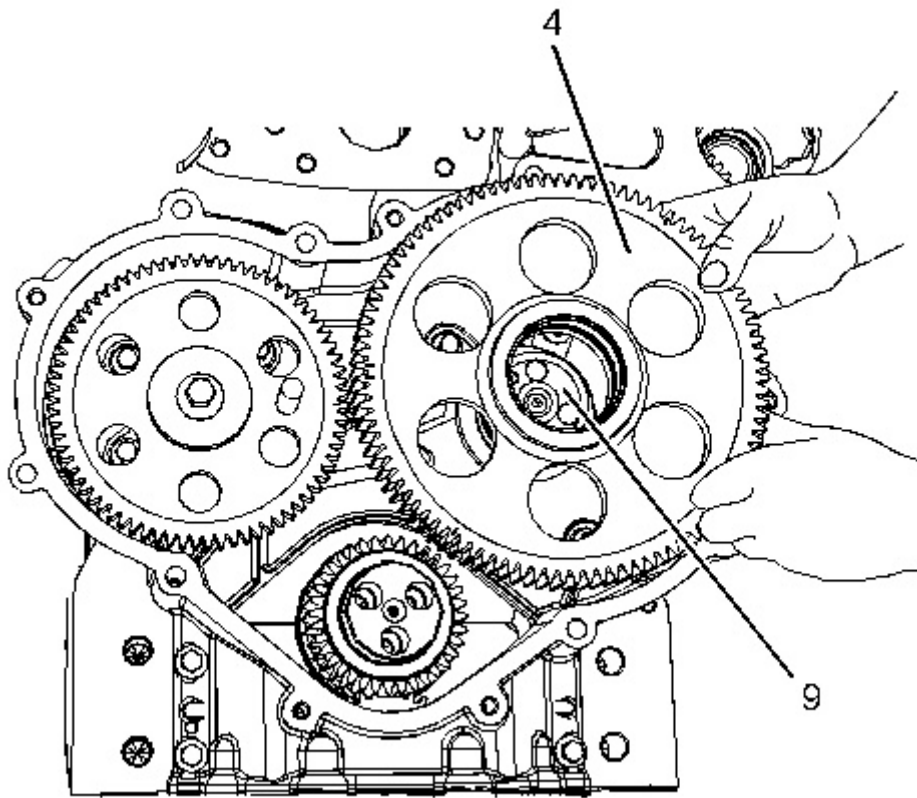

Illustration 5

g01994557

7. Mark plate (8) in order to show orientation.

Note: Identification will ensure that the plate can be installed in the original orientation.

8. Remove bolts (7).

9. Remove plate (8).

10. Remove the assembly of idler gear (4).

11. Remove hub (9) from the recess in the front housing.

Product: TRACK-TYPE TRACTOR

Model: D3K2 XL TRACK-TYPE TRACTOR KF2

Configuration: D3K2 XL & D3K2 LGP Small Track Type Tractor KF200001-UP (MACHINE) POWERED BY C4.4 Engine

Disassembly and Assembly C4.4 Engines for Caterpillar Built Machines

Media Number -UENR4516-11

Publication Date -01/06/2015

Date Updated -29/10/2018

i05820291

Idler Gear - Install

SMCS - 1206-012

Installation Procedure

Table 1

Required Tools			
Tool	Part Number	Part Description	Qty
A ⁽¹⁾	9U-6198	Crankshaft Turning Tool	1
A ⁽²⁾	5P-7306	Housing	1
	5P-7305	Engine Turning Tool	1
B	364-9107	Timing Pin (Fuel Injection Pump)	1
C	230-6284	Timing Pin (Camshaft)	1
D	136-4632	Timing Pin (Crankshaft)	1
	268-1966	Adapter	1
E	298-5564	T40 Torx Socket	1
F	9U-7324	Indicator Bracket	1
	7H-1942	Dial Indicator	1
	3S-3268	Indicator Contact Point	1
	7H-1940	Universal Attachment	1

⁽¹⁾ The Crankshaft Turning Tool is used on the front pulley.

⁽²⁾ This Tool is used in the aperture for the electric starting motor.

NOTICE

Keep all parts clean from contaminants.

Contaminants may cause rapid wear and shortened component life.

1. Ensure that number one piston is at top dead center on the compression stroke. Refer to System Operation, Testing and Adjusting, "Finding Top Center for No. 1 Piston" for the correct procedure.
-

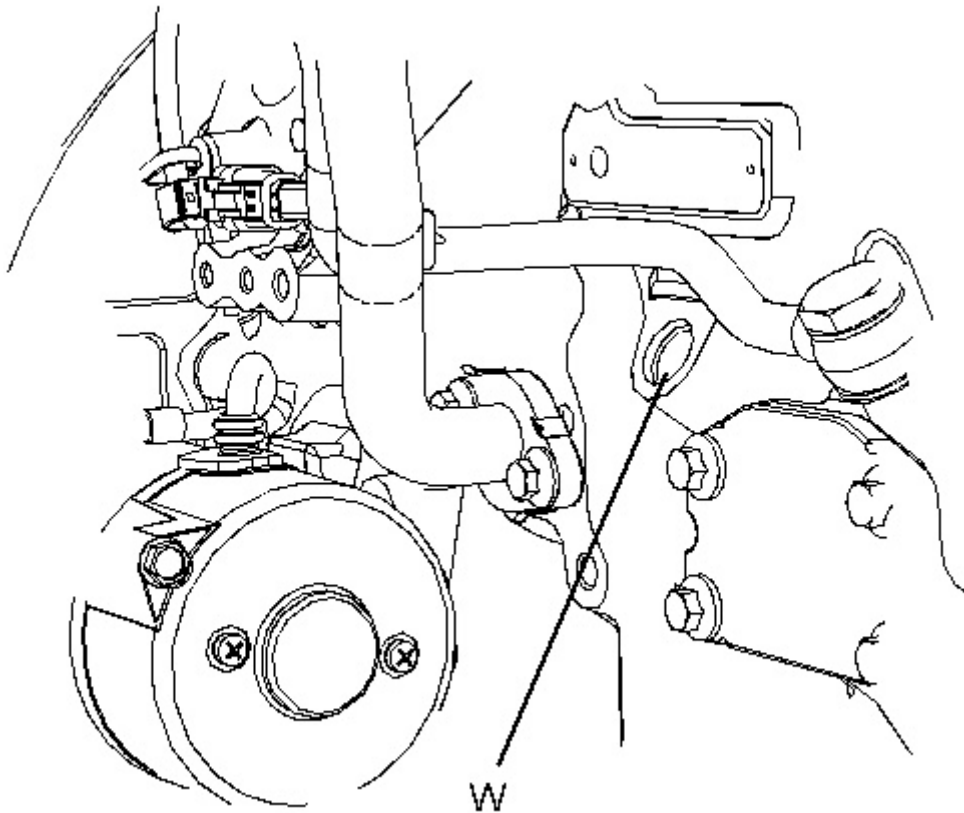

Illustration 1

g02491276

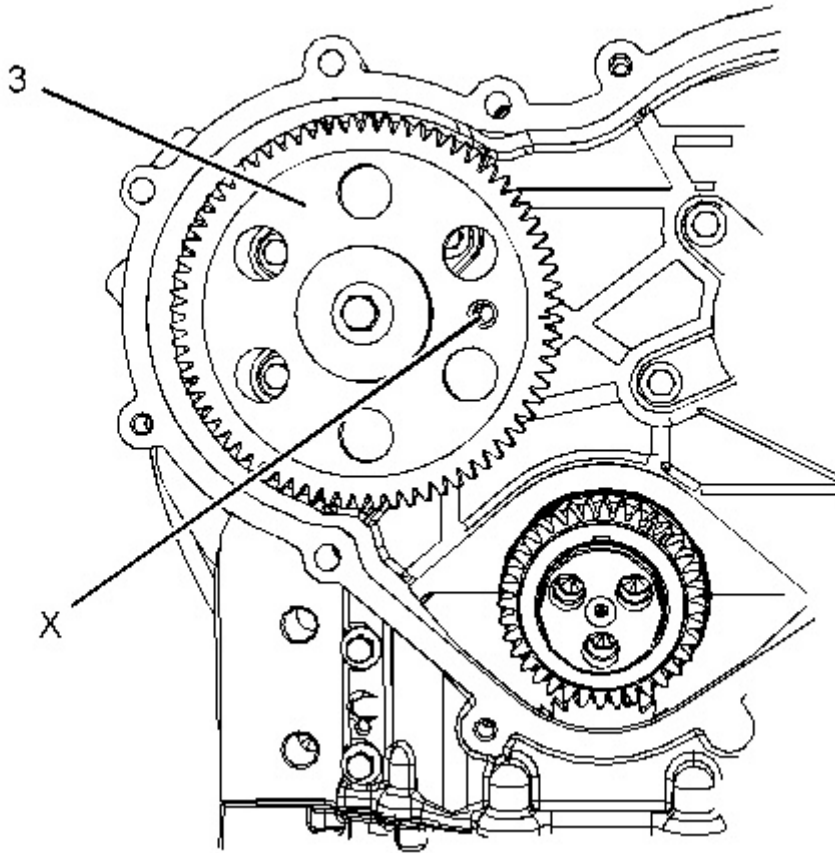

Illustration 2

g01996475

2. Ensure that Tooling (D) is installed in Hole (W) in the cylinder block. Use Tooling (D) in order to lock the crankshaft in the correct Position. Refer to System Operation, Testing and Adjusting, "Finding Top Center Position for No.1 Piston" for the correct procedure.
 3. Ensure that Tooling (C) is installed into Hole (X) in camshaft gear (3).
 4. Use Tooling (B) in order to lock the fuel injection pump gear in the correct position. Refer to Disassembly and Assembly, "Fuel Injection Pump - Remove" for the correct procedure.
-

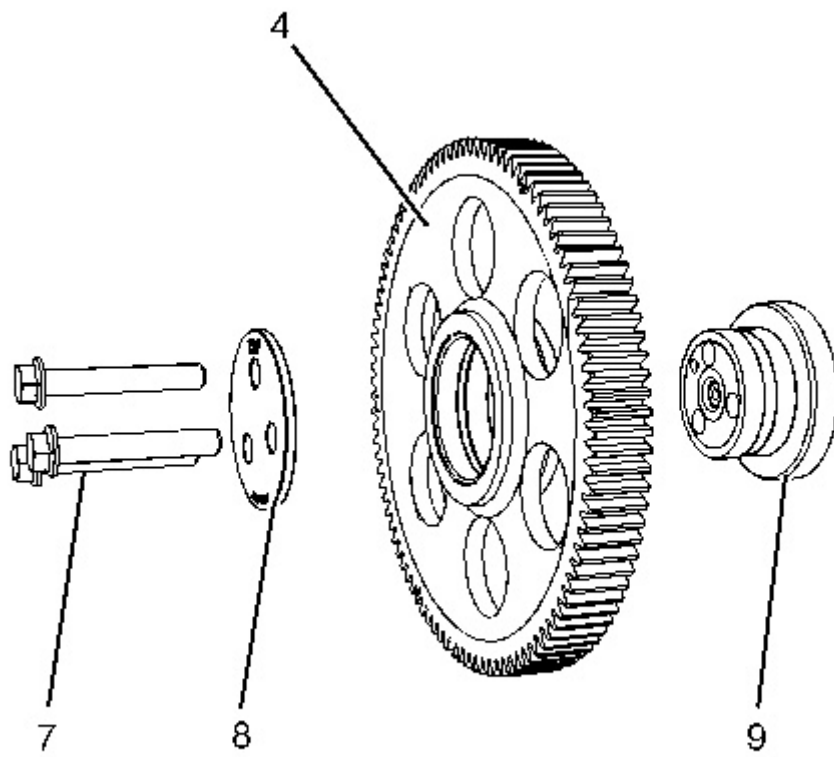

Illustration 3

g01996477

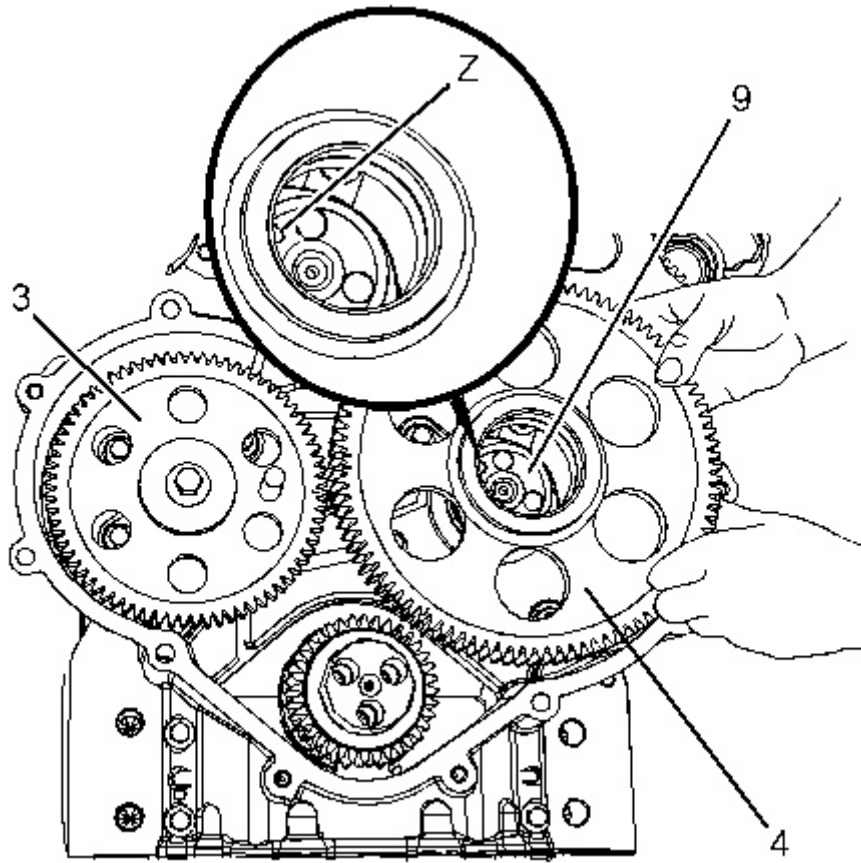

Illustration 4

g01996478

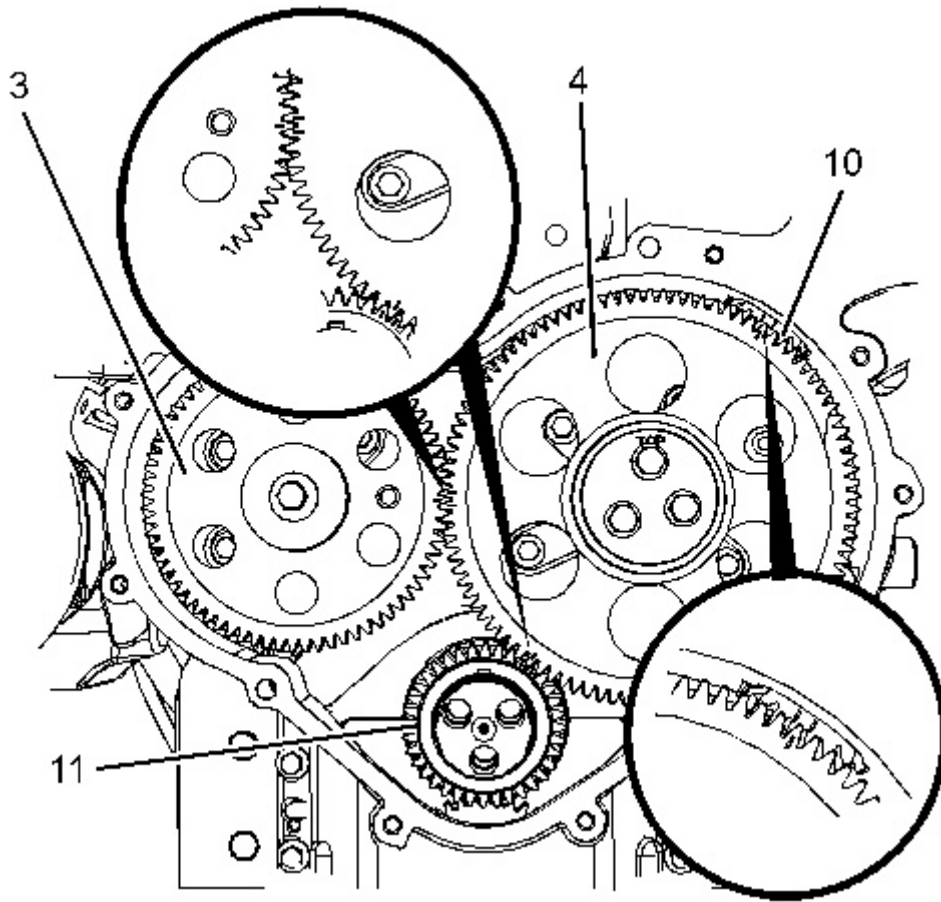

Illustration 5

g01996576

5. Clean idler gear (4) and inspect the idler gear for wear and damage. Refer to Specifications, "Gear Group (Front)" for more information. If necessary, replace the idler gear.
 6. Clean hub (9) and inspect the hub for wear and damage. Refer to Specifications, "Gear Group (Front)" for more information. If necessary, replace the hub.
 7. Lubricate hub (9) with clean engine oil. Install hub (9) into the recess in the front housing. Ensure that oil Hole (Z) is to the top of the hub.
 8. Install idler gear (4) onto hub (9). Ensure that the timing marks are toward the front of the idler gear.
 9. Align the timing mark on idler gear (4) with the timing mark on camshaft gear (3), fuel injection pump gear (10) and crankshaft gear (11). Refer to the Illustration 5. Install the assembly of idler gear (4) to hub (9).
 10. Clean plate (8) and inspect the plate for wear and damage. If necessary, replace the plate.
 11. Lubricate plate (8) with clean engine oil. Align the holes in plate (8) with the holes in hub (9). Install the plate in the original orientation.
- Note:** Ensure that the identification mark TOP is upward.
12. Install bolts (7). Tighten the bolts to a torque of 44 N·m (32 lb ft).
 13. Remove Tooling (B), Tooling (C), and Tooling (D).

Note: Ensure that timing marks are aligned, before removing the Tooling (B), Tooling (C), and Tooling (D).

14. Use Tooling (F) in order to check the end play for the idler gear. Refer to Specifications, "Gear Group (Front)" for more information.
15. Use Tooling (F) in order to check the backlash between the idler gear and the camshaft gear. Refer to Specifications, "Gear Group (Front)" for more information.
16. Use Tooling (F) in order to check the backlash between the idler gear and the crankshaft gear. Refer to Specifications, "Gear Group (Front)" for more information.
17. Use Tooling (F) in order to check the backlash between the idler gear and the fuel injection pump gear. Refer to Specifications, "Gear Group (Front)" for more information.
18. Lightly lubricate all of the gears with clean engine oil.

NOTICE

Failure to ensure that the crankshaft is set in the safe position will result in interference between the pistons and the valves. Interference between the pistons and the valves will result in damage to the engine.

19. Use Tooling (A) in order to rotate the crankshaft in a clockwise direction and position the crankshaft at the safe position. Refer to System Operation, Testing and Adjusting, "Position the Valve Mechanism Before Maintenance Procedures" for the correct procedure.
-

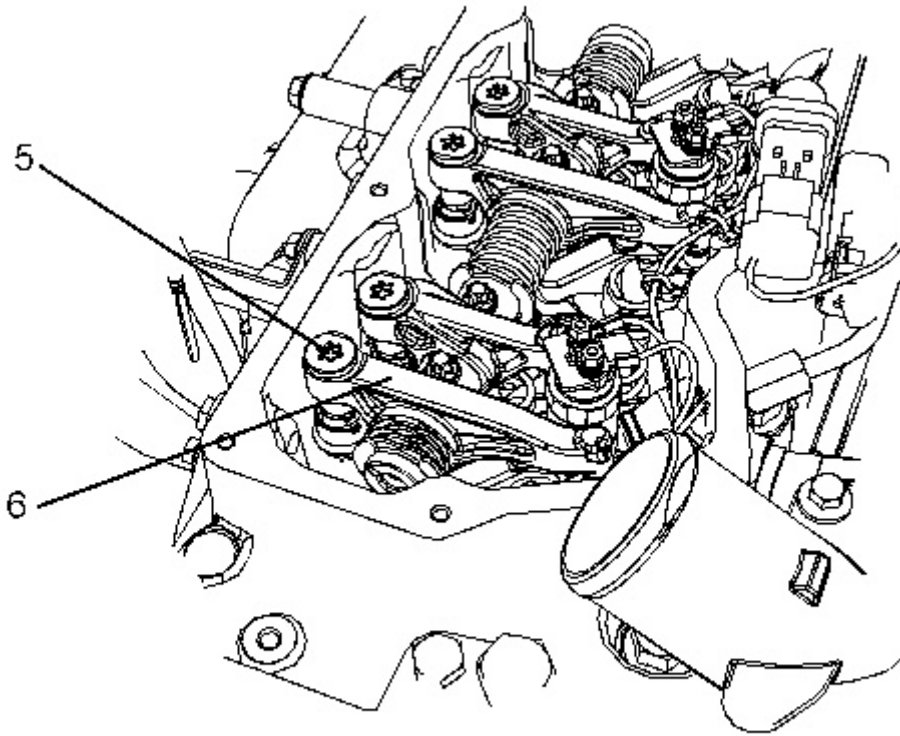

Illustration 6

g01994556

20. Ensure that the guides for the pushrods are correctly positioned on the threaded inserts (5). Use Tooling (E) in order to tighten threaded inserts (5) on all rocker arms (6). Tighten the threaded inserts to a torque of 30 N·m (265 lb in).

Note: When the threaded insert is tightened, the threaded insert must be seated correctly into the cup for the pushrod.

21. The engine should not be operated for a period 45 minutes after the threaded inserts on all the rocker arms have been tightened. This period will allow the force of the valve springs to purge off excessive engine oil from the hydraulic lifters.
-

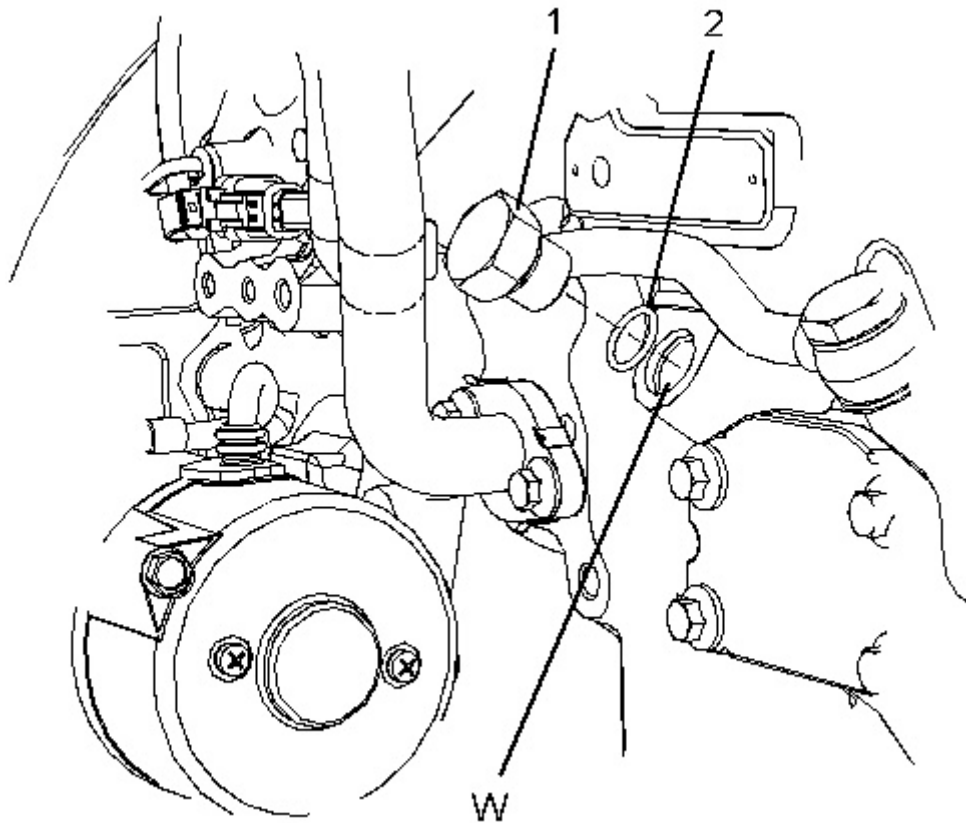

Illustration 7

g02485936

22. Position a new O-ring seal (2) onto plug (1). Install the plug to the cylinder block and tighten the plug to a torque of 21 N·m (186 lb in).

End By:

- a. Install the front cover. Refer to Disassembly and Assembly, "Front Cover - Remove and Install" for the correct procedure.
 - b. Install the valve mechanism cover. Refer to Disassembly and Assembly, "Valve Mechanism Cover - Remove and Install" for the correct procedure.
-

Product: TRACK-TYPE TRACTOR

Model: D3K2 XL TRACK-TYPE TRACTOR KF2

Configuration: D3K2 XL & D3K2 LGP Small Track Type Tractor KF200001-UP (MACHINE) POWERED BY C4.4 Engine

Disassembly and Assembly

C4.4 Engines for Caterpillar Built Machines

Media Number -UENR4516-11

Publication Date -01/06/2015

Date Updated -29/10/2018

i05820292

Housing (Front) - Remove

SMCS - 1151-011

Removal Procedure

Start By:

- a. Remove the fan. Refer to Disassembly and Assembly, "Fan - Remove and Install" for the correct procedure.
- b. Remove the crankshaft pulley. Refer to Disassembly and Assembly, "Crankshaft Pulley - Remove and Install" for the correct procedure.
- c. Remove the engine oil pan. Refer to Disassembly and Assembly, "Engine Oil Pan - Remove" for the correct procedure.
- d. If the engine has an accessory drive, remove the accessory drive. Refer to Disassembly and Assembly, "Accessory Drive - Remove and Install" for the correct procedure.
- e. Remove the water pump. Refer to Disassembly and Assembly, "Water Pump - Remove" for the correct procedure.
- f. Remove the timing gears. Refer to Disassembly and Assembly, "Gear Group (Front) - Remove and Install" for the correct procedure.
- g. Remove the fuel injection pump. Refer to Disassembly and Assembly, "Fuel Injection Pump - Remove" for the correct procedure.

NOTICE

Keep all parts clean from contaminants.

Contaminants may cause rapid wear and shortened component life.

NOTICE

Care must be taken to ensure that fluids are contained during performance of inspection, maintenance, testing, adjusting and repair of the product. Be prepared to collect the fluid with suitable containers before opening any compartment or disassembling any component containing fluids.

Dispose of all fluids according to local regulations and mandates.

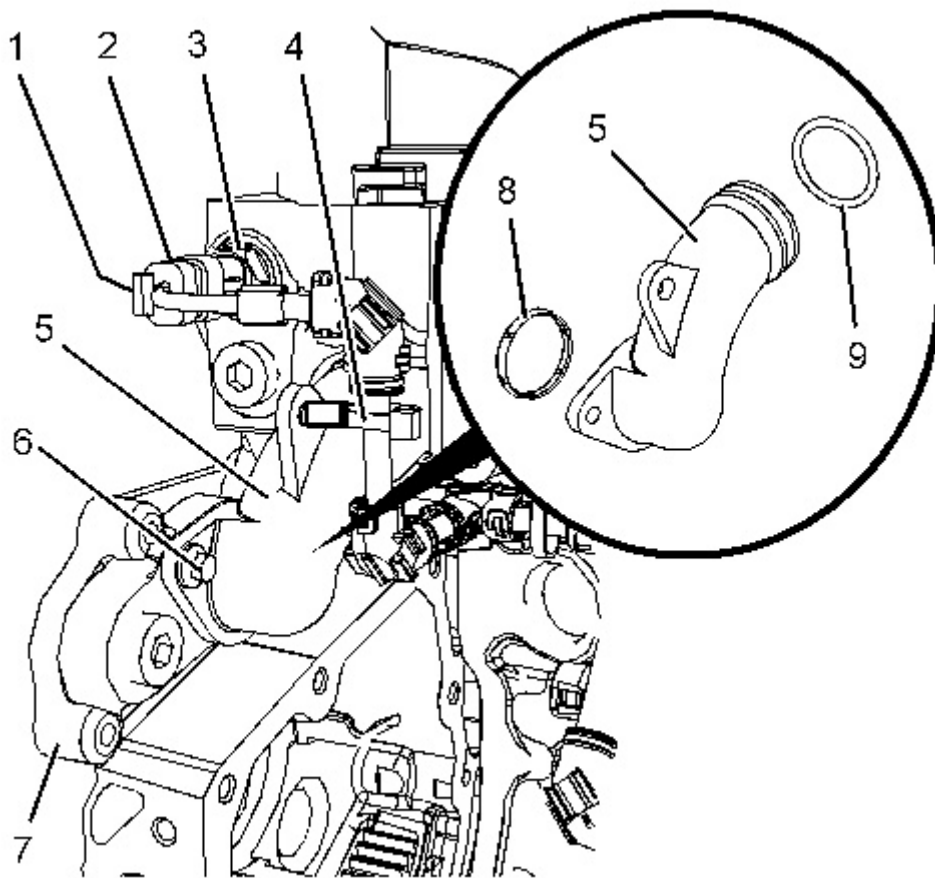

Illustration 1

g02488340

1. Slide locking tab (1) (not shown) into the unlocked position.
2. Disconnect harness assembly (2) from coolant temperature sensor (3).
3. Cut cable strap (4) and remove harness assembly (2) from bypass tube (5).
4. Remove bolts (6) that secure bypass tube (5) to front housing (7).

5. Remove bypass tube (5) from the cylinder head. Remove O-ring seal (8) and O-ring seal (9) from bypass tube (5).
-

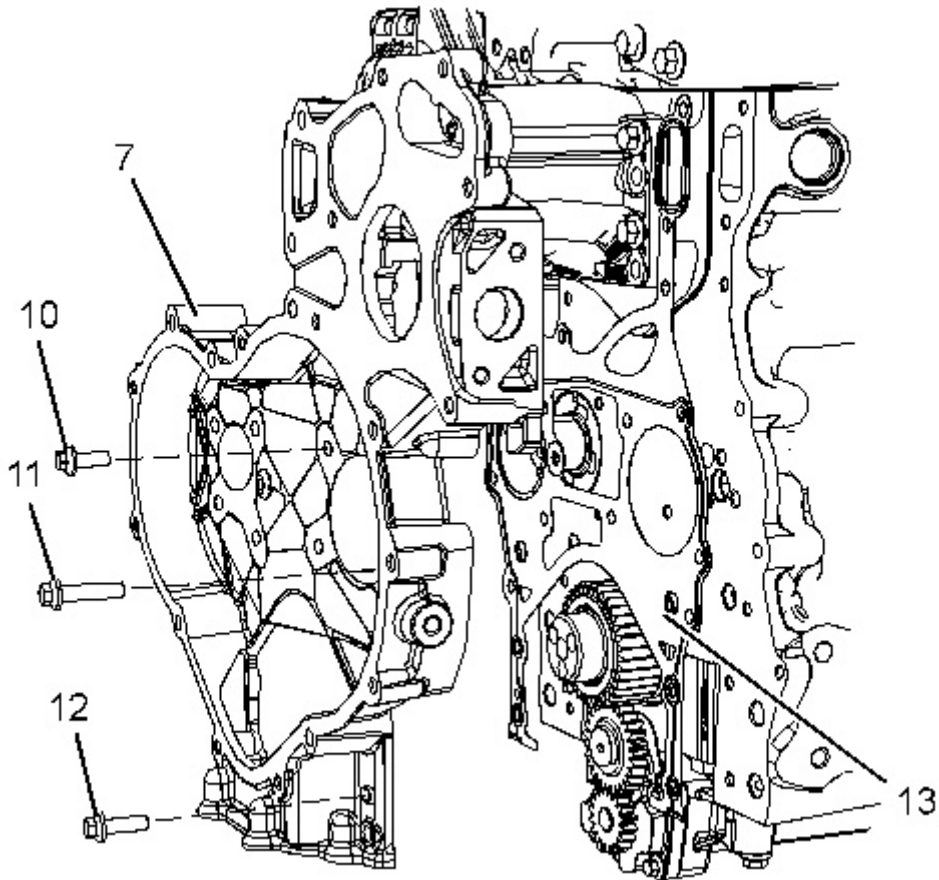

Illustration 2

g02488341

6. Remove bolts (10), bolts (11) and bolts (12) from front housing (7).

Note: The bolts are three different lengths. Note the positions of the different bolts.

7. Remove front housing (7) from the cylinder block.

8. Remove gasket (13).
-

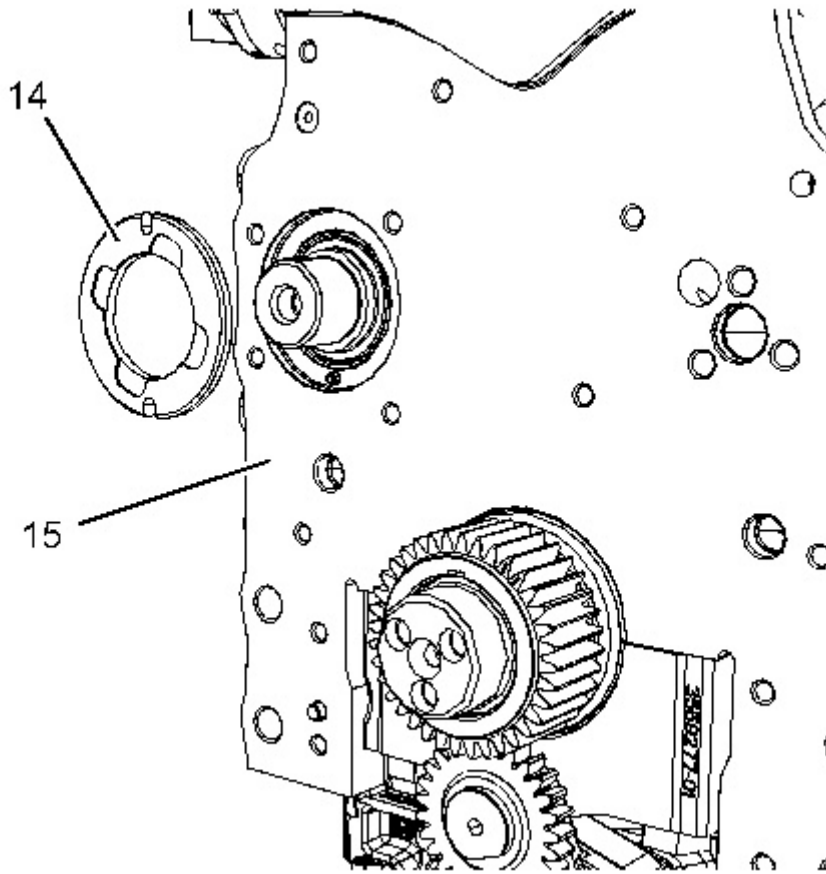

Illustration 3

g02488356

9. Remove thrust washer (14) from cylinder block (15).

Product: TRACK-TYPE TRACTOR

Model: D3K2 XL TRACK-TYPE TRACTOR KF2

Configuration: D3K2 XL & D3K2 LGP Small Track Type Tractor KF200001-UP (MACHINE) POWERED BY C4.4 Engine

Disassembly and Assembly

C4.4 Engines for Caterpillar Built Machines

Media Number -UENR4516-11

Publication Date -01/06/2015

Date Updated -29/10/2018

i05820293

Housing (Front) - Remove - Heavy Duty Housing (Front)

SMCS - 1151-011

Removal Procedure

Start By:

- a. Remove the fan. Refer to Disassembly and Assembly, "Fan - Remove and Install" for the correct procedure.
- b. Remove the crankshaft pulley. Refer to Disassembly and Assembly, "Crankshaft Pulley - Remove" for the correct procedure.
- c. Remove the engine oil pan. Refer to Disassembly and Assembly, "Engine Oil Pan - Remove" for the correct procedure.
- d. If the engine has an accessory drive, remove the accessory drive. Refer to Disassembly and Assembly, "Accessory Drive - Remove and Install" for the correct procedure.
- e. Remove the water pump. Refer to Disassembly and Assembly, "Water Pump - Remove" for the correct procedure.
- f. Remove the timing gears. Refer to Disassembly and Assembly, "Gear Group (Front) - Remove and Install" for the correct procedure.
- g. Remove the fuel injection pump. Refer to Disassembly and Assembly, "Fuel Injection Pump - Remove" for the correct procedure.

NOTICE

Keep all parts clean from contaminants.

Contaminants may cause rapid wear and shortened component life.

NOTICE

Care must be taken to ensure that fluids are contained during performance of inspection, maintenance, testing, adjusting and repair of the product. Be prepared to collect the fluid with suitable containers before opening any compartment or disassembling any component containing fluids.

Dispose of all fluids according to local regulations and mandates.

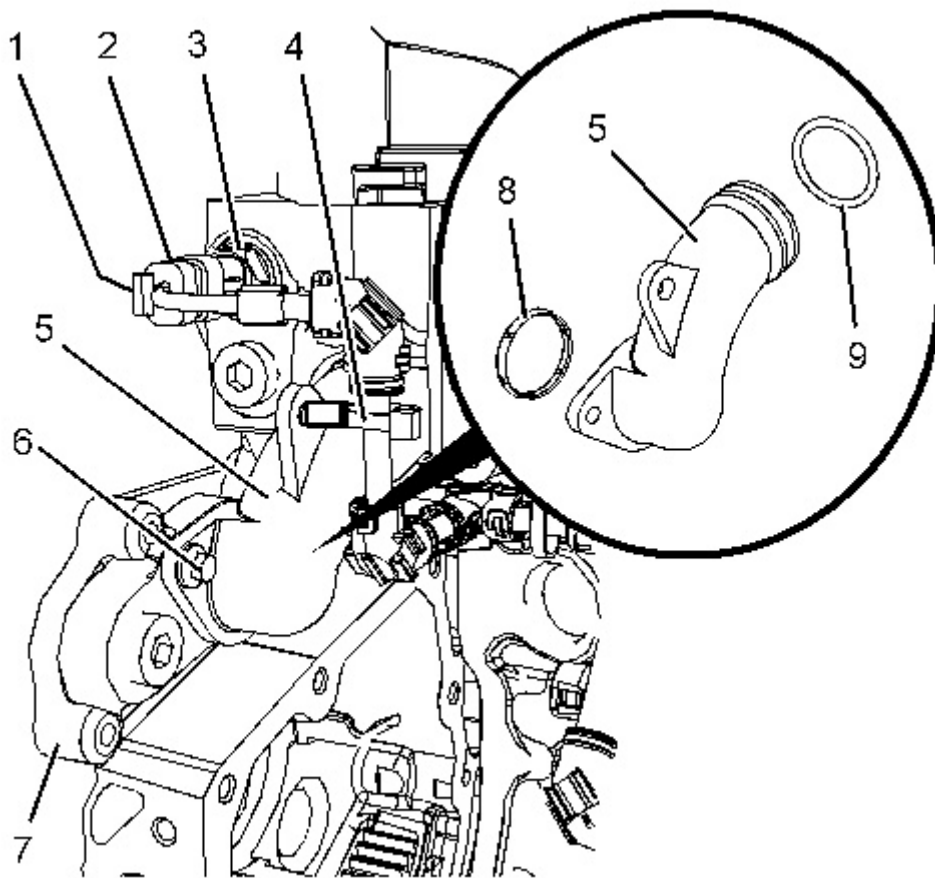

Illustration 1

g02490356

1. Slide locking tab (1) (not shown) into the unlocked position.
2. Disconnect harness assembly (2) from coolant temperature sensor (3).
3. Cut cable strap (4) and remove harness assembly (2) from bypass tube (5).
4. Remove bolts (6) that secure bypass tube (5) to front housing (7).

5. Remove bypass tube (5) from the cylinder head. Remove O-ring seal (8) and O-ring seal (9) from bypass tube (5).
-

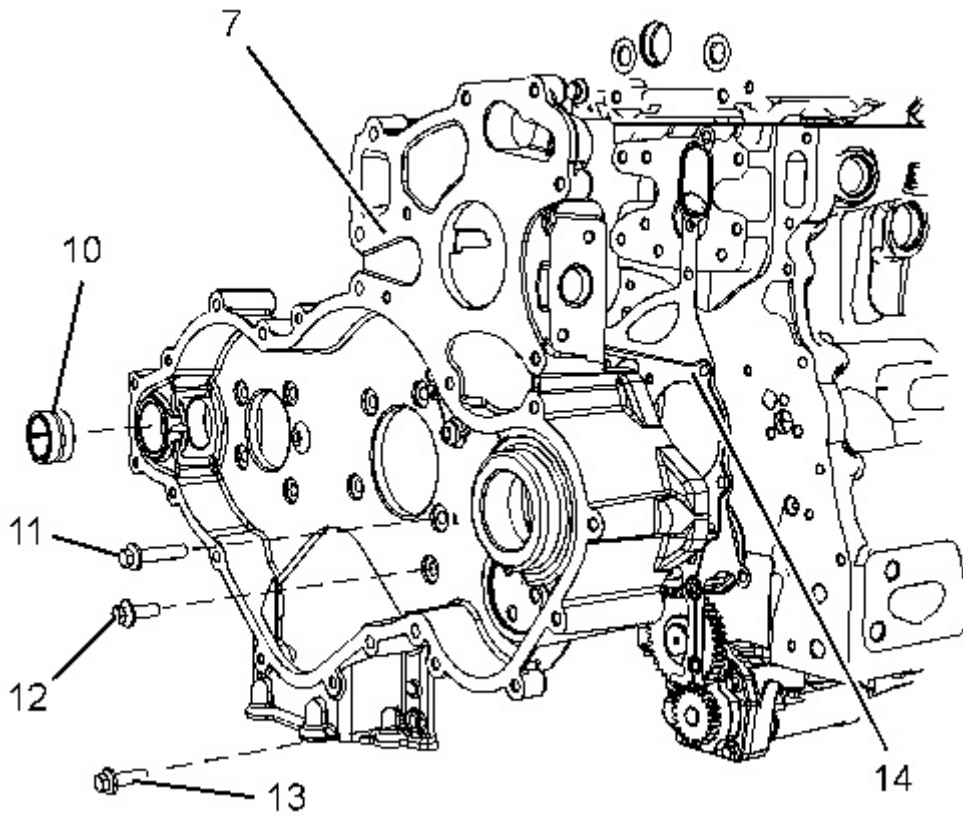

Illustration 2

g02490357

6. Remove bolts (11), bolts (12) and bolts (13) from front housing (7).

Note: The bolts are three different lengths. Note the positions of the bolts of different length.

7. Remove front housing (7) from the cylinder block.
8. Remove gasket (14).
9. If necessary, follow Step 9.a through Step 9.b in order to remove bearing (10) from housing (7).
- a. Place housing (7) onto a suitable support.
 - b. Use a suitable tool in order to press bearing (10) out of housing (7).
-

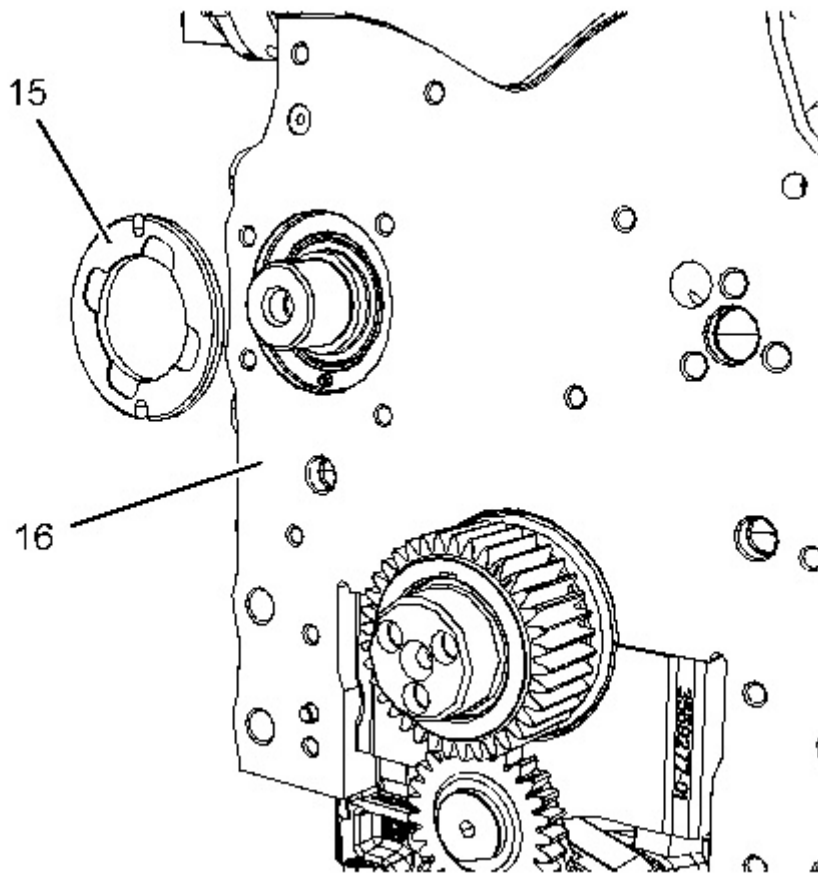

Illustration 3

g02490358

10. Remove thrust washer (15) from cylinder block (16).
-

Product: TRACK-TYPE TRACTOR

Model: D3K2 XL TRACK-TYPE TRACTOR KF2

Configuration: D3K2 XL & D3K2 LGP Small Track Type Tractor KF200001-UP (MACHINE) POWERED BY C4.4 Engine

Disassembly and Assembly C4.4 Engines for Caterpillar Built Machines

Media Number -UENR4516-11

Publication Date -01/06/2015

Date Updated -29/10/2018

i05820294

Housing (Front) - Install - Heavy Duty Housing (Front)

SMCS - 1151-012

Installation Procedure

Table 1

Required Tools			
Tool	Part Number	Part Description	Qty
A	6V-6640	Sealant	1
B	-	Guide Studs M8 by 80 mm	2
C	319-6486	Alignment Tool	1
	-	Bolts M10 by 50 mm	3
D	1U-6396	O-Ring Assembly Compound	1
E	7M-7456	Bearing Mount Compound	1

NOTICE

Keep all parts clean from contaminants.

Contaminants may cause rapid wear and shortened component life.

NOTICE

Ensure that the wiring harness assembly is correctly routed and the cable straps are not over tightened. Over tightening of the cable straps will damage the wiring harness and the convoluting.

1. Ensure that the front housing is clean and free from damage. If necessary, replace the front housing.

If necessary, install blanking plugs to a new front housing. Use Tooling (A) in order to seal all D-plugs.

2. Clean all the gasket surfaces of the cylinder block.
-

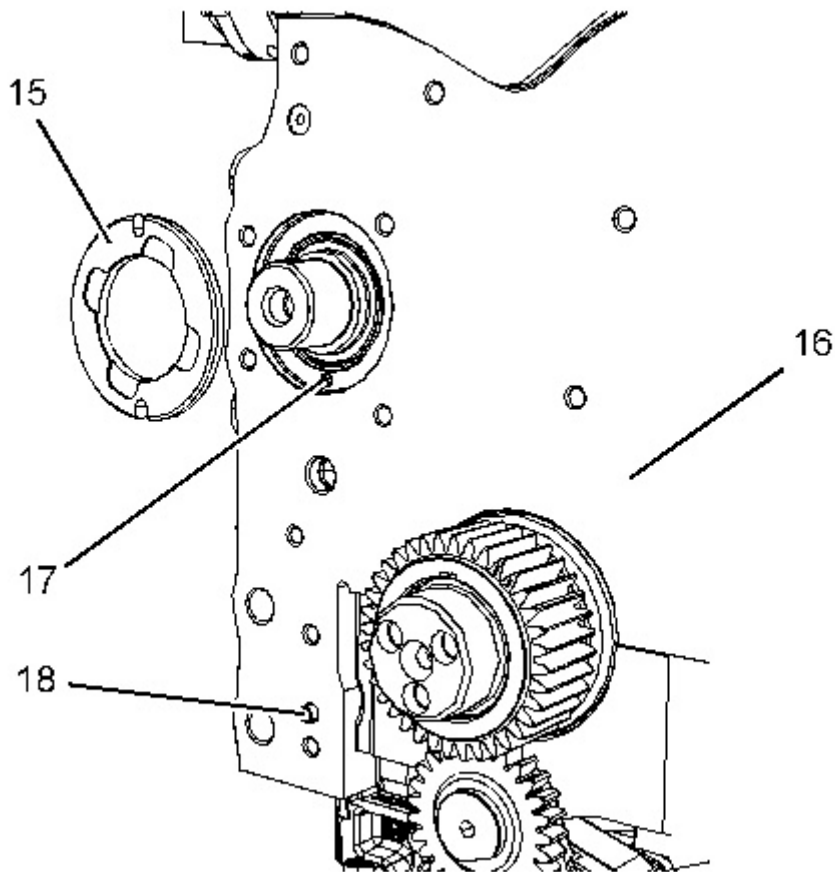

Illustration 1

g02490396

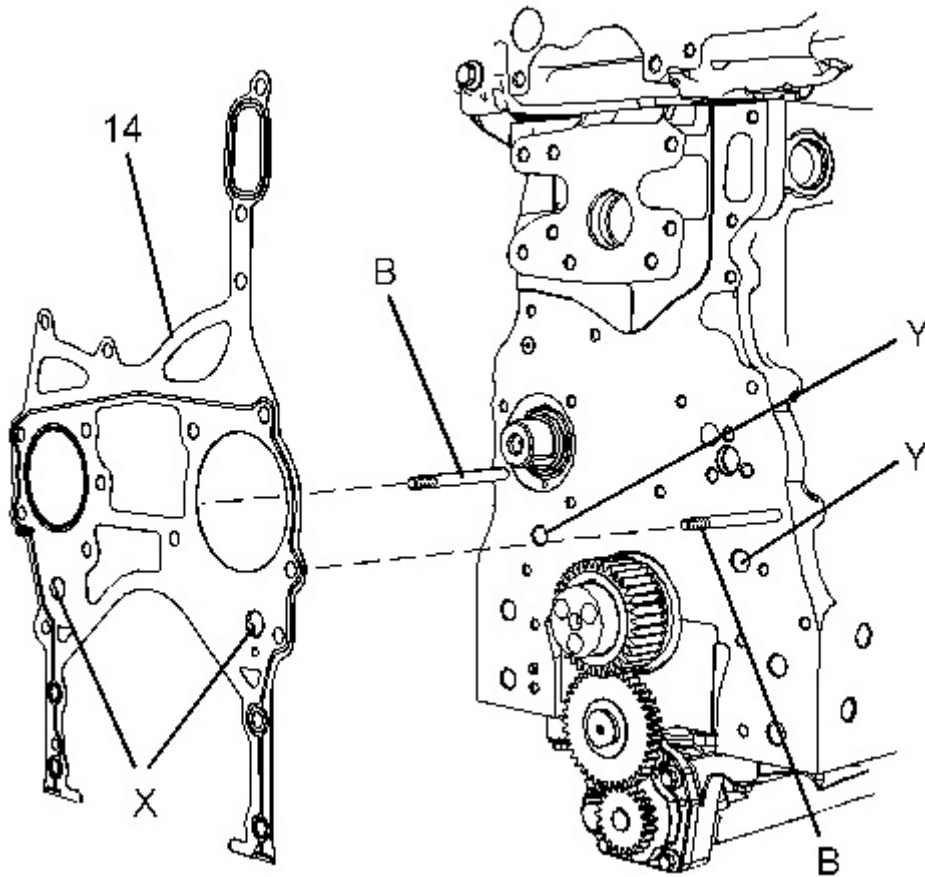

Illustration 2

g02490397

3. Inspect dowel (17) and dowel (18) for damage. If necessary, replace the dowels in the cylinder block.
4. Install thrust washer (15) into the recess in cylinder block (16). Refer to Disassembly and Assembly, "Camshaft - Install" for more information.
5. Install Tooling (B) to cylinder block (16). Refer to Illustration 2.
6. Align a new gasket (10) with Tooling (B). Install the gasket to (16) cylinder block.

Note: Ensure that two circular Tabs (X) on the gasket are engaged in two Holes (Y) in cylinder block (16). Ensure that dowel (18) in cylinder block (16) is engaged on the gasket.

7. Install Tooling (C) to cylinder block (16).
-

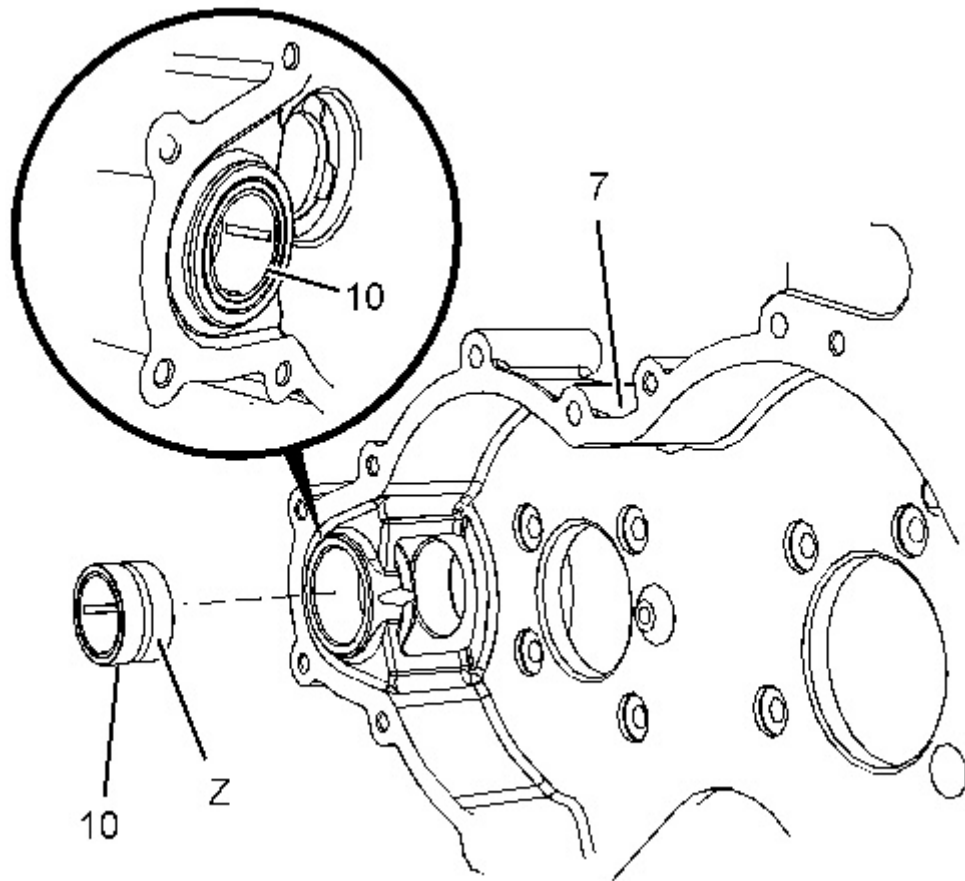

Illustration 3

g02490399

8. If necessary, follow Step 8.a through Step 8.c in order to install bearing (10) to housing (7).
 - a. Apply a small continuous bead of Tooling (E) to outer Surface (Z) of bearing (10).
 - b. Place housing (7) onto a suitable support.
 - c. Use a suitable tool in order to press bearing (10) into housing (7) until the bearing is in the correct position within the housing. Remove any excess bearing mount compound.
 9. Install the front housing over Tooling (B) and Tooling (C) onto cylinder block (16).
-

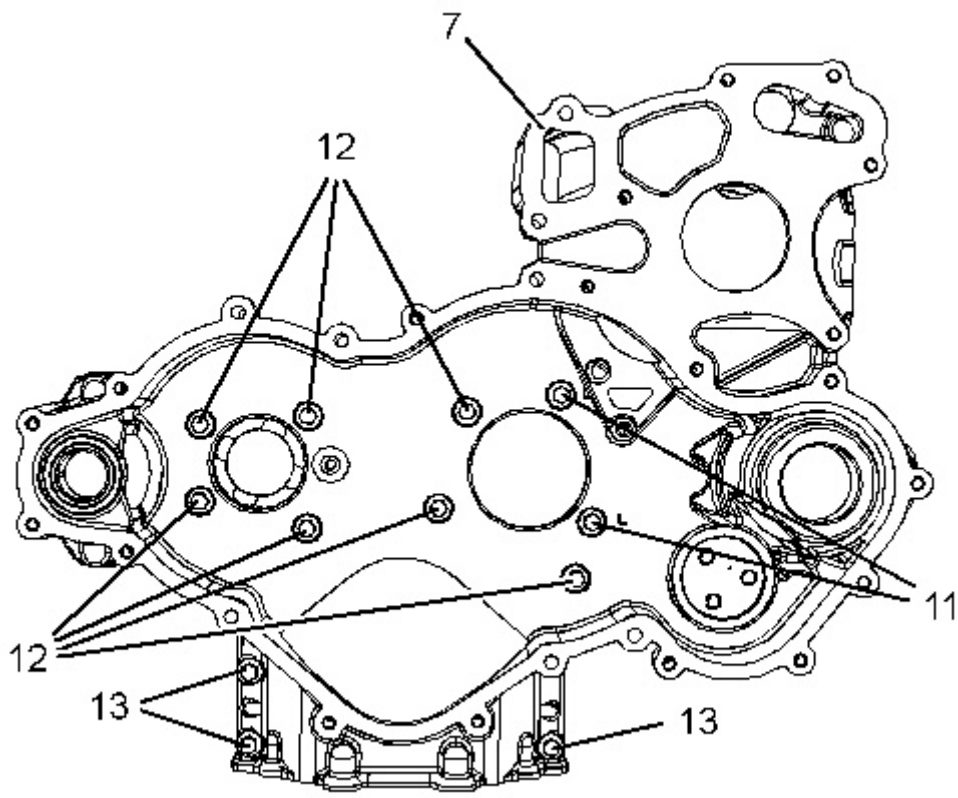

Illustration 4

g02490400

- (11) M8 by 35 mm
 - (12) M8 by 20 mm
 - (13) M8 by 25 mm
-

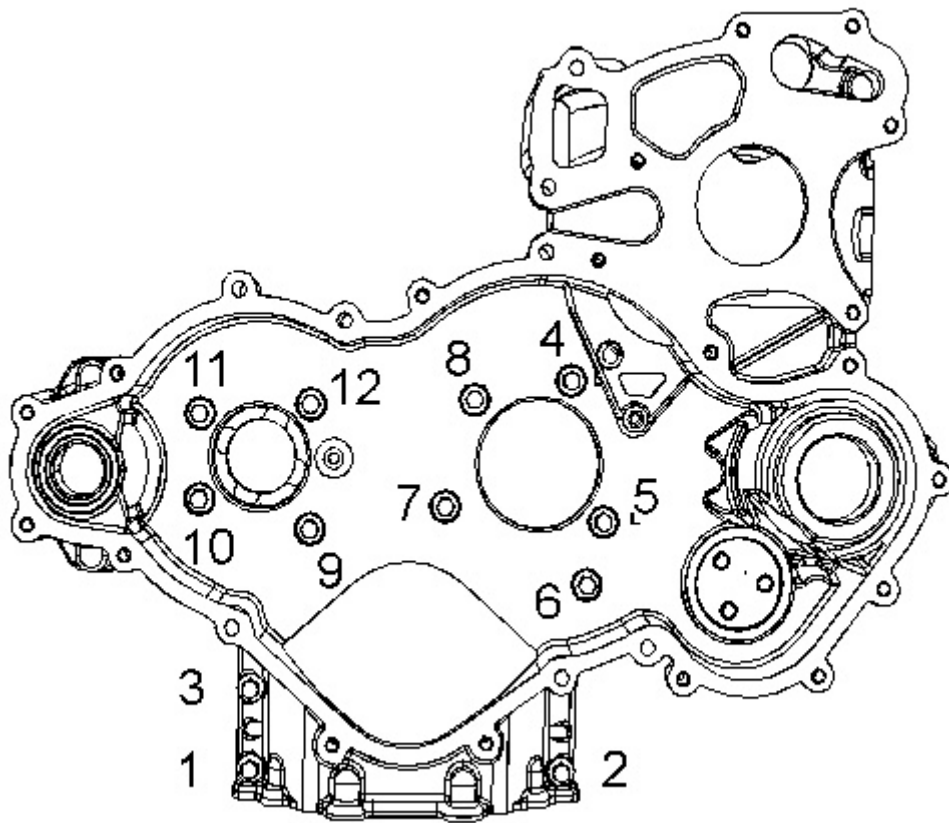

Illustration 5

g02058297

10. Install bolts (13) to front housing (7) finger tight.
 11. Remove Tooling (B).
 12. Loosely install bolts (11) and bolts (12). Refer to Illustration 4 for the correct position of the bolts.
 13. Tighten bolts (11), bolts (12) and bolts (13) in the sequence that is shown in Illustration 5 to a torque of 28 N·m (248 lb in).
 14. Remove Tooling (C) from the cylinder block.
-

Thank you so much for reading.
Please click the “Buy Now!”
button below to download the
complete manual.



After you pay.

You can download the most
perfect and complete manual in
the world immediately.

Our support email:

ebooklibonline@outlook.com