

Product: TRACK-TYPE TRACTOR

Model: D5N TRACK-TYPE TRACTOR AKD

Configuration: D5N XL, LGP TRACK-TYPE TRACTOR AKD00001-UP (MACHINE) POWERED BY 3126B Engine

Disassembly and Assembly 3126B Engines for Caterpillar Built Machines

Media Number -SEN9581-06

Publication Date -01/08/2018

Date Updated -17/08/2018

i01196838

Camshaft - Remove

SMCS - 1210-011

Removal Procedure

Start By:

- a. Remove the lifter group. Refer to Disassembly and Assembly, "Lifter Group - Remove and Install".
- b. Remove the front cover. Refer to Disassembly and Assembly, "Front Cover - Remove".

NOTICE

Keep all parts clean from contaminants.

Contaminants may cause rapid wear and shortened component life.

NOTICE

Care must be taken to ensure that fluids are contained during performance of inspection, maintenance, testing, adjusting, and repair of the product. Be prepared to collect the fluid with suitable containers before opening any compartment or disassembling any component containing fluids.

Refer to Special Publication, NENG2500, "Dealer Service Tool Catalog" for tools and supplies suitable to collect and contain fluids on Cat products.

Dispose of all fluids according to local regulations and mandates.

1. Turn the crankshaft to top center compression stroke for the No. 1 piston. Install the timing bolt in the flywheel. This is for timing during installation.
2. Ensure that the timing marks on the following gears are aligned: the camshaft drive gear, the idler gear and the crankshaft gear.

Note: It is not necessary to remove the cylinder head for removal of the camshaft.

3. Wire the valve lifters away from the camshaft.

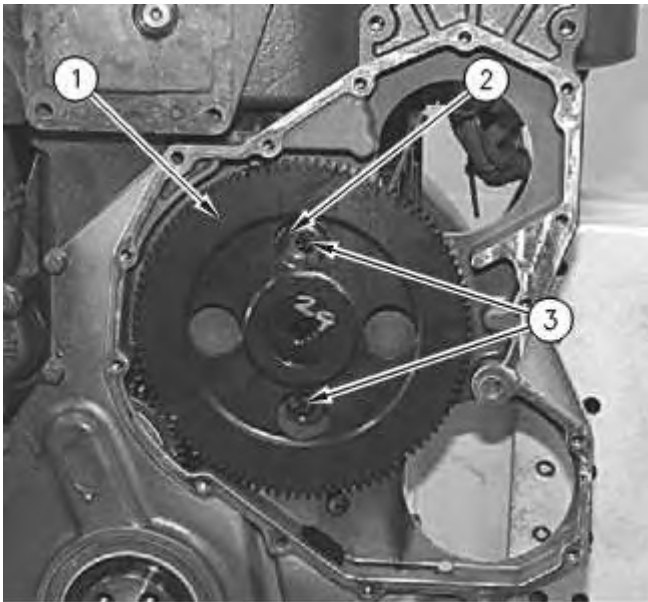

Illustration 1

g00640035

4. Remove two bolts (3) and camshaft retainer plate (2) from camshaft gear (1).

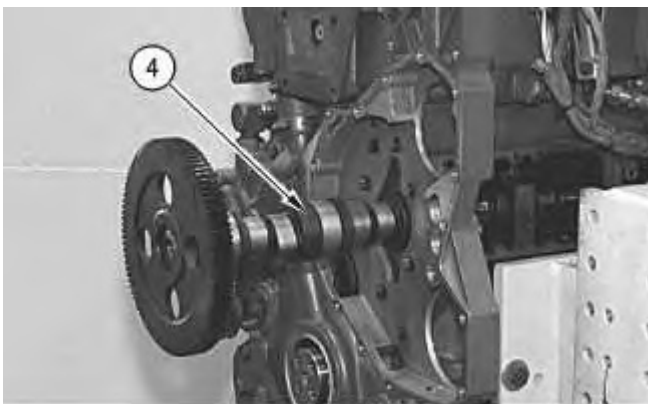

Illustration 2

g00640030

5. Remove camshaft (4) from the cylinder block.
-

Product: TRACK-TYPE TRACTOR

Model: D5N TRACK-TYPE TRACTOR AKD

Configuration: D5N XL, LGP TRACK-TYPE TRACTOR AKD00001-UP (MACHINE) POWERED BY 3126B Engine

Disassembly and Assembly 3126B Engines for Caterpillar Built Machines

Media Number -SEN9581-06

Publication Date -01/08/2018

Date Updated -17/08/2018

i01196611

Camshaft - Install

SMCS - 1210-012

Installation Procedure

NOTICE

Keep all parts clean from contaminants.

Contaminants may cause rapid wear and shortened component life.

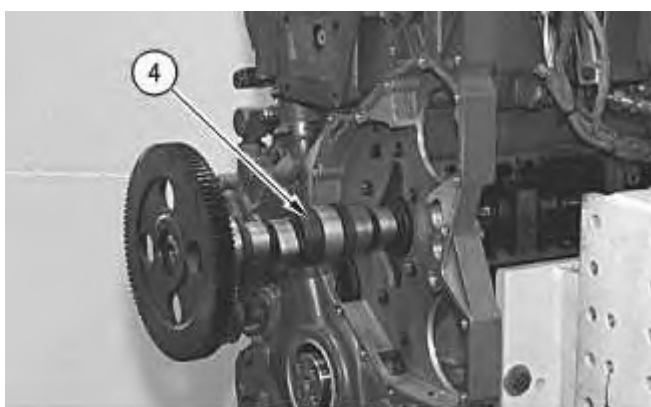

Illustration 1

g00640030

1. Carefully install camshaft (4) in the engine.

NOTICE

When installing the camshaft, make sure the number one cylinder is at top center of the compression stroke with the timing bolt installed in the flywheel. The camshaft timing is very important. The timing mark on the camshaft drive gear must line up with the timing mark on the idler gear. Refer to the Specifications Manual for more information.

2. Ensure that the timing marks on the following gears are aligned: the camshaft drive gear, the idler gear and the crankshaft gear.

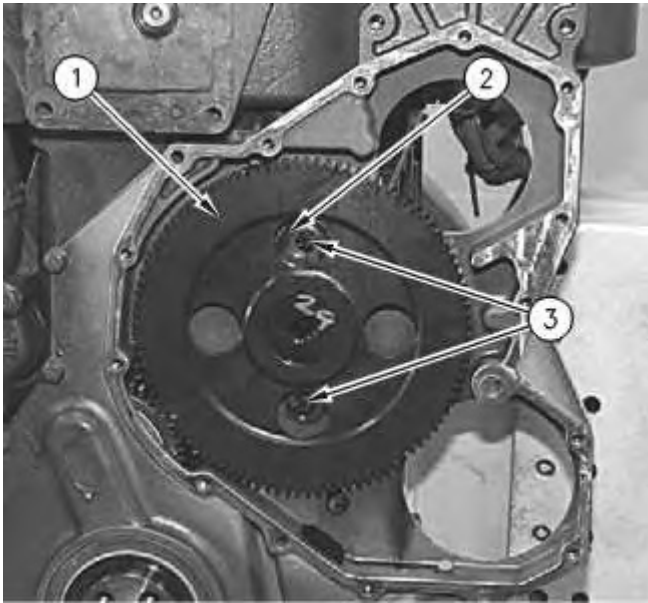

Illustration 2

g00640035

3. Install camshaft retainer plate (2) and two bolts (3) on camshaft gear (1).

End By:

- a. Install the front cover. Refer to Disassembly and Assembly, "Front Cover - Install".
 - b. Install the lifter group. Refer to Disassembly and Assembly, "Lifter Group - Remove and Install".
-

Product: TRACK-TYPE TRACTOR

Model: D5N TRACK-TYPE TRACTOR AKD

Configuration: D5N XL, LGP TRACK-TYPE TRACTOR AKD00001-UP (MACHINE) POWERED BY 3126B Engine

Disassembly and Assembly 3126B Engines for Caterpillar Built Machines

Media Number -SEN9581-06

Publication Date -01/08/2018

Date Updated -17/08/2018

i01983227

Camshaft Gear - Remove and Install

SMCS - 1210-010-GE

Removal Procedure

Start By:

- a. Remove the camshaft. Refer to Disassembly and Assembly, "Camshaft - Remove".
1. Wrap the camshaft with a protective covering in order to prevent damage to the camshaft.

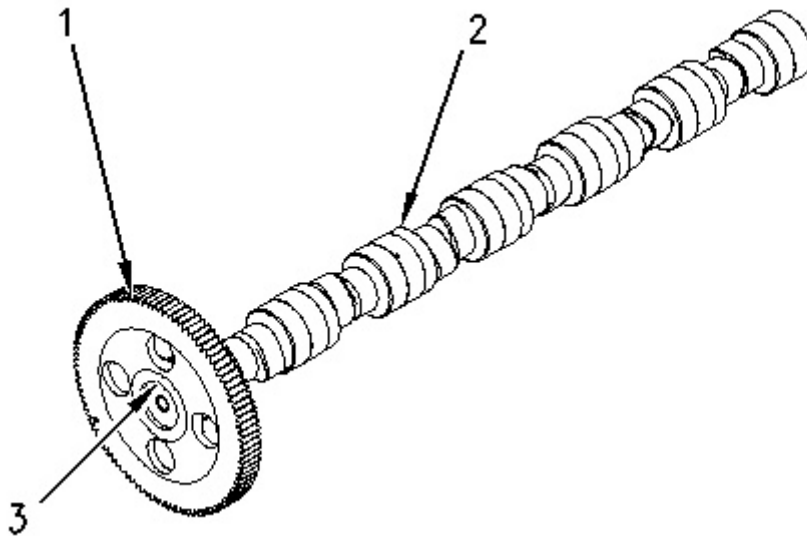

Illustration 1

g00987675

NOTICE

Do not allow the camshaft to fall to the floor when pressing it from the drive gear. Also make sure that the camshaft lobes do not catch on the press plates.

2. Place camshaft (2) and camshaft gear (1) in a suitable press. Press camshaft (2) from camshaft gear (1).
3. If necessary, remove the key (3) from the camshaft.

Installation Procedure

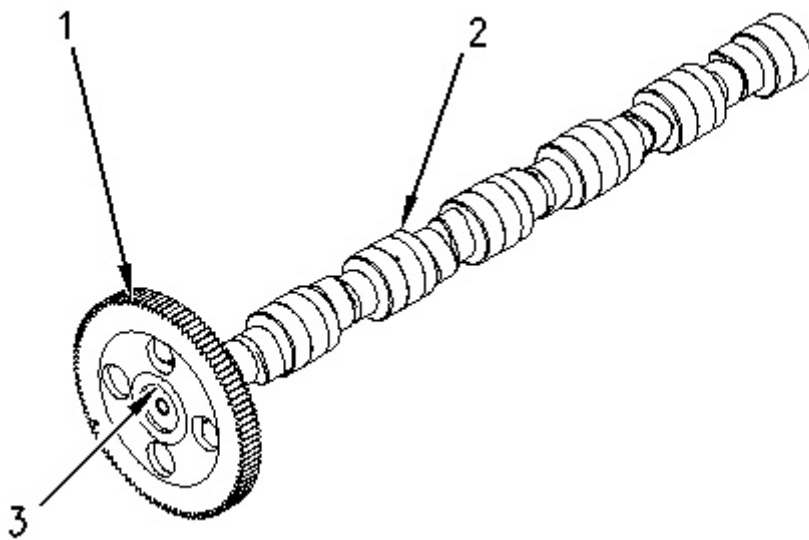

Illustration 2

g00987675

1. Raise the temperature of camshaft gear (1).
2. Align key (3) in the camshaft with the groove (keyway) in the camshaft gear.
3. Install camshaft gear (1) on the end of camshaft (2).

End By:

- a. Install the camshaft. Refer to Disassembly and Assembly, "Camshaft - Install".
-

Product: TRACK-TYPE TRACTOR

Model: D5N TRACK-TYPE TRACTOR AKD

Configuration: D5N XL, LGP TRACK-TYPE TRACTOR AKD00001-UP (MACHINE) POWERED BY 3126B Engine

Disassembly and Assembly 3126B Engines for Caterpillar Built Machines

Media Number -SEN9581-06

Publication Date -01/08/2018

Date Updated -17/08/2018

i02183087

Camshaft Bearings - Remove and Install

SMCS - 1211-010

Removal Procedure

Table 1

Required Tools			
Tool	Part Number	Part Description	Qty
A	8S-2241	Camshaft Bearing Tool Group	1

Start By:

- Remove the camshaft. Refer to Disassembly and Assembly, "Camshaft - Remove".

NOTICE

Keep all parts clean from contaminants.

Contaminants may cause rapid wear and shortened component life.

NOTICE

Care must be taken to ensure that fluids are contained during performance of inspection, maintenance, testing, adjusting, and repair of the product. Be prepared to collect the fluid with suitable containers before opening any compartment or disassembling any component containing fluids.

Refer to Special Publication, NENG2500, "Dealer Service Tool Catalog" for tools and supplies suitable to collect and contain fluids on Cat products.

Dispose of all fluids according to local regulations and mandates.

Note: Note the oil hole orientation in each camshaft bearing prior to removal for assembly purposes.

1. Use Tooling (A) to remove the camshaft bearings from the cylinder block.

Installation Procedure

Table 2

Required Tools			
Tool	Part Number	Part Description	Qty
A	8S-2241	Camshaft Bearing Tool Group	1

NOTICE

Keep all parts clean from contaminants.

Contaminants may cause rapid wear and shortened component life.

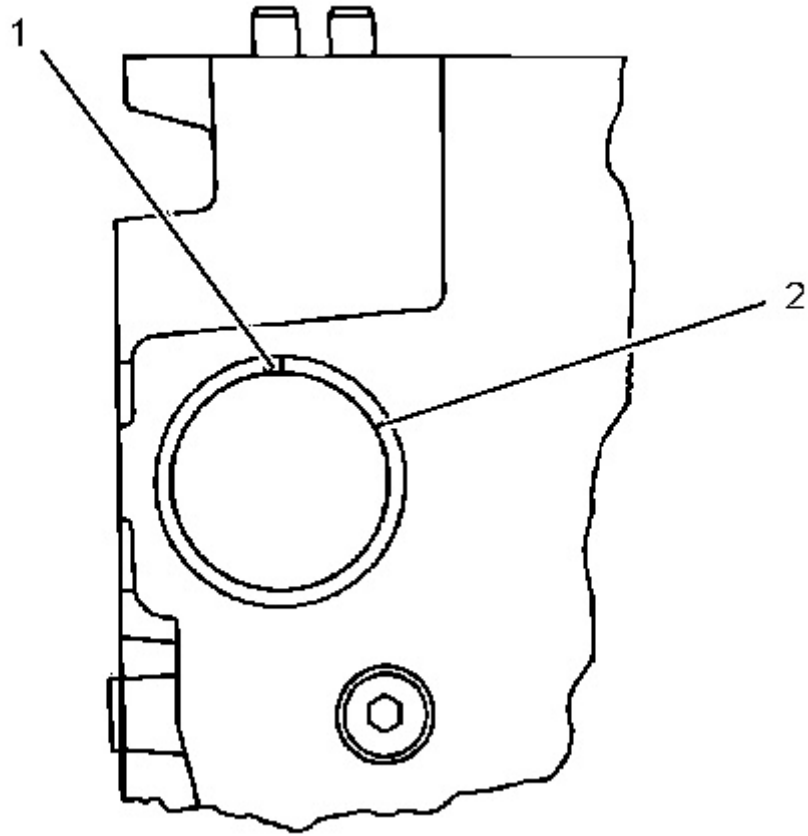

Illustration 1

g01104577

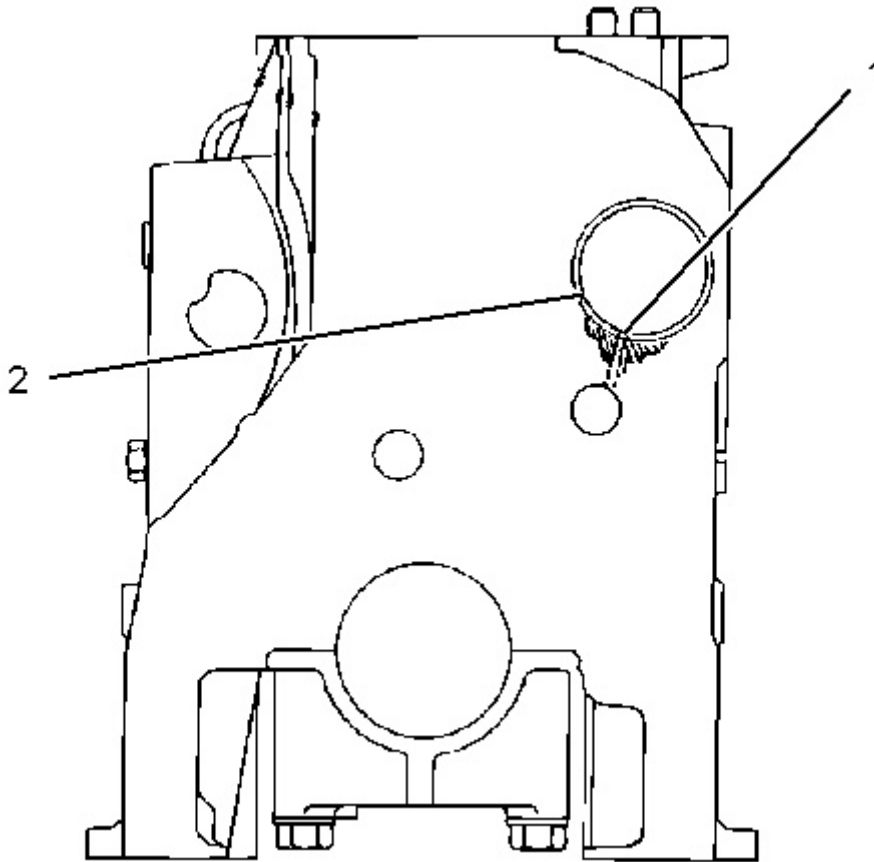

Illustration 2

g01104579

1. Use Tooling (A) to install all of the camshaft bearings except for the front bearing. Orient oil hole (1) in each bearing so that oil hole (1) is located at the top of the bore.
2. Use Tooling (A) to install the front camshaft bearing. Align oil hole (1) in the front camshaft bearing with the oil hole in the cylinder block. Locate joint (2) in the front camshaft bearing in the proper position.

End By:

- a. Install the camshaft. Refer to Disassembly and Assembly, "Camshaft - Install".
-

Product: TRACK-TYPE TRACTOR

Model: D5N TRACK-TYPE TRACTOR AKD

Configuration: D5N XL, LGP TRACK-TYPE TRACTOR AKD00001-UP (MACHINE) POWERED BY 3126B Engine

Disassembly and Assembly 3126B Engines for Caterpillar Built Machines

Media Number -SEN9581-06

Publication Date -01/08/2018

Date Updated -17/08/2018

i02173704

Engine Oil Pan - Remove and Install

SMCS - 1302-010

Removal Procedure



Hot oil and components can cause personal injury.

Do not allow hot oil or components to contact skin.

NOTICE

Keep all parts clean from contaminants.

Contaminants may cause rapid wear and shortened component life.

NOTICE

Care must be taken to ensure that fluids are contained during performance of inspection, maintenance, testing, adjusting and repair of the product. Be prepared to collect the fluid with suitable containers before opening any compartment or disassembling any component containing fluids.

Refer to Special Publication, NENG2500, "Caterpillar Tools and Shop Products Guide" for tools and supplies suitable to collect and contain fluids on Caterpillar products.

Dispose of all fluids according to local regulations and mandates.

1. Drain the engine oil into a suitable container for storage or disposal.

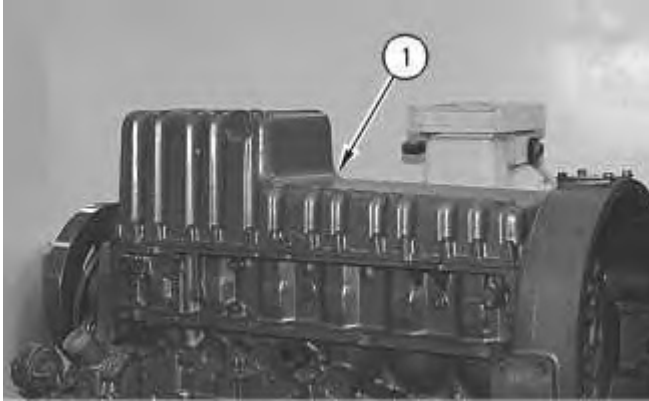

Illustration 1

g00610543

Typical example

Note: Do not pry or gouge the sealing surface of the engine oil pan. Use a rubber mallet to tap lightly on the engine oil pan, if it is necessary.

2. Remove the bolts for engine oil pan (1). Remove engine oil pan (1) .

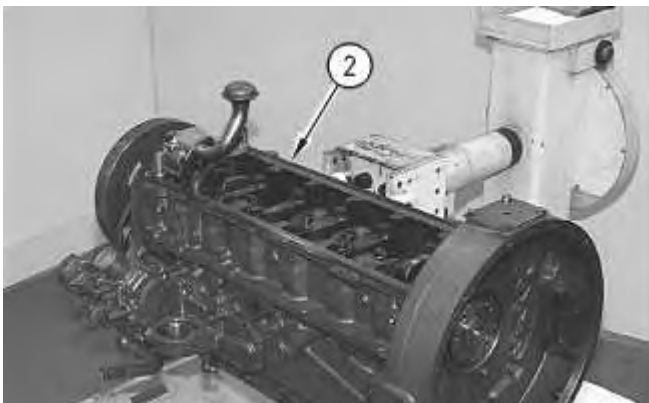

Illustration 2

g00610550

Typical example

3. Remove gasket (2) from engine oil pan (1) .
4. Remove the drain plug and the O-ring seal from engine oil pan (1) .

Installation Procedure

Table 1

Required Tools			
Tool	Part Number	Part Description	Qty
A	4C-9612	Silicone Sealant	1

NOTICE

Keep all parts clean from contaminants.

Contaminants may cause rapid wear and shortened component life.

1. Install the drain plug and the O-ring seal on the engine oil pan. Tighten the drain plug to $25 \pm 5 \text{ N}\cdot\text{m}$ ($18 \pm 4 \text{ lb ft}$).
2. Inspect the condition of the gasket. Replace the gasket, if necessary.

Note: On newer engines, the oil pan has an integral seal. Inspect the condition of the seal and replace the seal, if necessary.

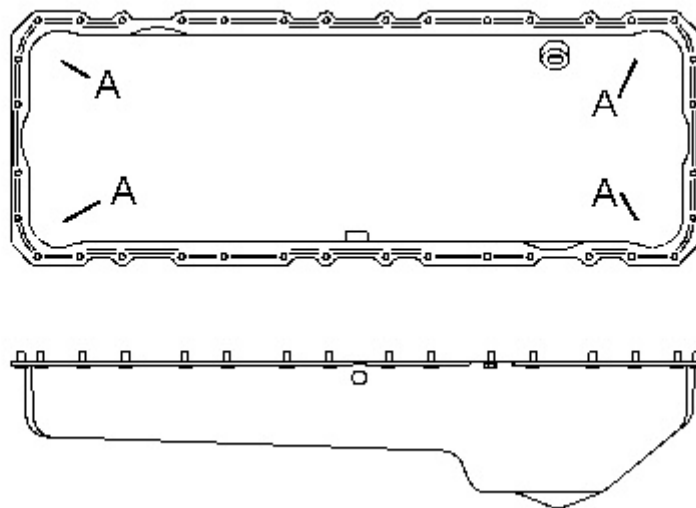

3. Clean the mating surface of the engine oil pan and the cylinder block.
4. Apply Tooling (A) to the T-shaped gasket joints of the oil pan. Refer to Illustration 3.

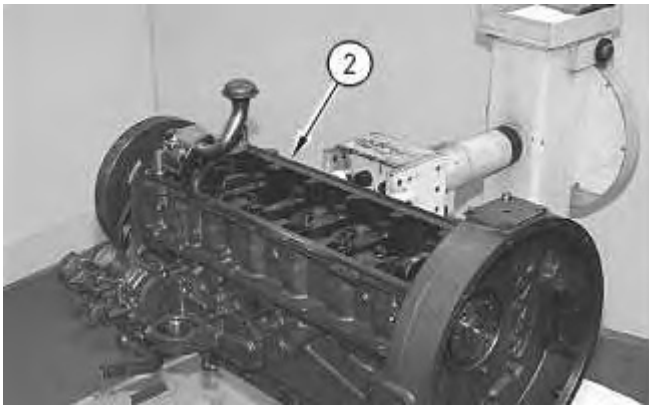

Illustration 4

g00610550

Typical example

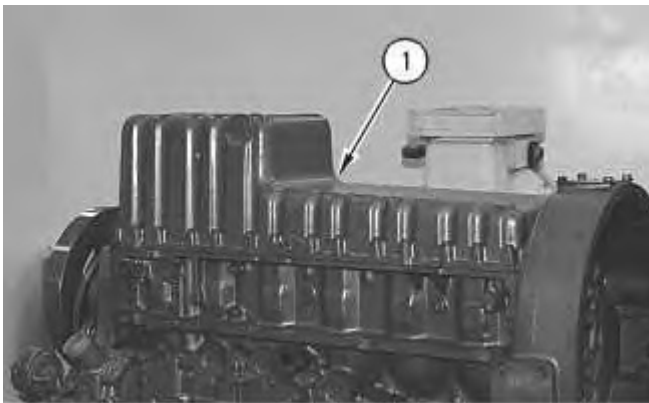

Illustration 5

g00610543

Typical example

5. Position new gasket (2) and engine oil pan (1) on the cylinder block.
-

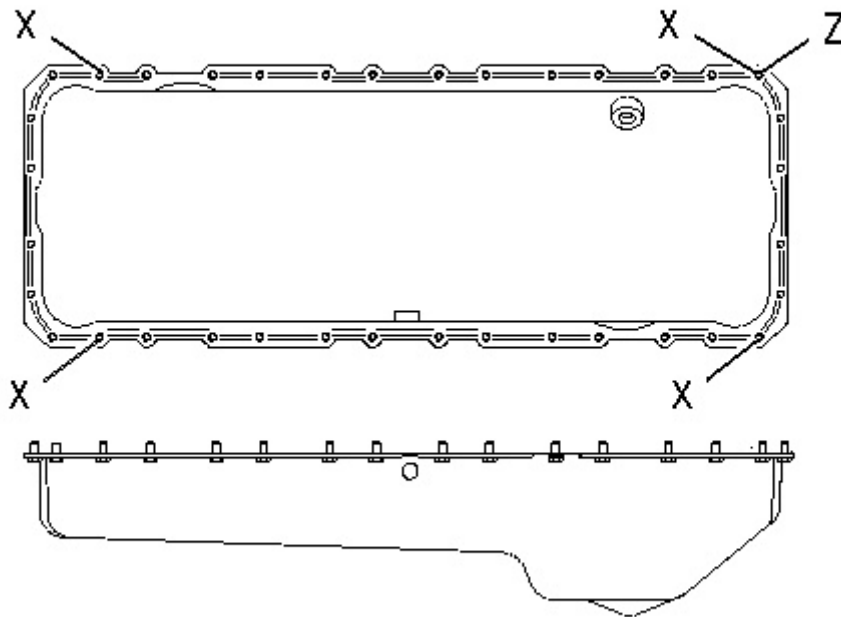

Illustration 6

g00610574

6. Install the bolts for the engine oil pan. Tighten Bolts (X) to a torque of $31 \pm 3 \text{ N}\cdot\text{m}$ ($23 \pm 2 \text{ lb ft}$).
 7. Start at Bolt (Z) and tighten the remaining bolts in a counterclockwise direction. Tighten the remaining bolts to a torque of $31 \pm 3 \text{ N}\cdot\text{m}$ ($23 \pm 2 \text{ lb ft}$).
 8. Start at Bolt (Z) and tighten the bolts again in a counterclockwise direction. Tighten the bolts to a torque of $31 \pm 3 \text{ N}\cdot\text{m}$ ($23 \pm 2 \text{ lb ft}$).
 9. Fill the engine with oil to the correct level. Refer to the Operation and Maintenance Manual for the correct filling procedure.
-

Product: TRACK-TYPE TRACTOR

Model: D5N TRACK-TYPE TRACTOR AKD

Configuration: D5N XL, LGP TRACK-TYPE TRACTOR AKD00001-UP (MACHINE) POWERED BY 3126B Engine

Disassembly and Assembly 3126B Engines for Caterpillar Built Machines

Media Number -SEN9581-06

Publication Date -01/08/2018

Date Updated -17/08/2018

i02372739

Piston Cooling Jets - Remove and Install

SMCS - 1331-010

Removal Procedure

Start By:

- a. Remove the engine oil pan. Refer to Disassembly and Assembly, "Engine Oil Pan - Remove and Install".

NOTICE

Keep all parts clean from contaminants.

Contaminants may cause rapid wear and shortened component life.

NOTICE

Care must be taken to ensure that fluids are contained during performance of inspection, maintenance, testing, adjusting, and repair of the product. Be prepared to collect the fluid with suitable containers before opening any compartment or disassembling any component containing fluids.

Refer to Special Publication, NENG2500, "Dealer Service Tool Catalog" for tools and supplies suitable to collect and contain fluids on Cat products.

Dispose of all fluids according to local regulations and mandates.

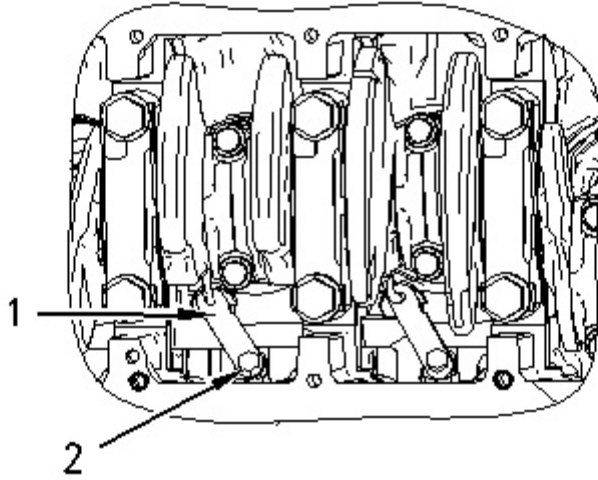

Illustration 1

g00987444

1. Remove bolt (2) and piston cooling jet (1) from each cylinder.

Installation Procedure

NOTICE

Keep all parts clean from contaminants.

Contaminants may cause rapid wear and shortened component life.

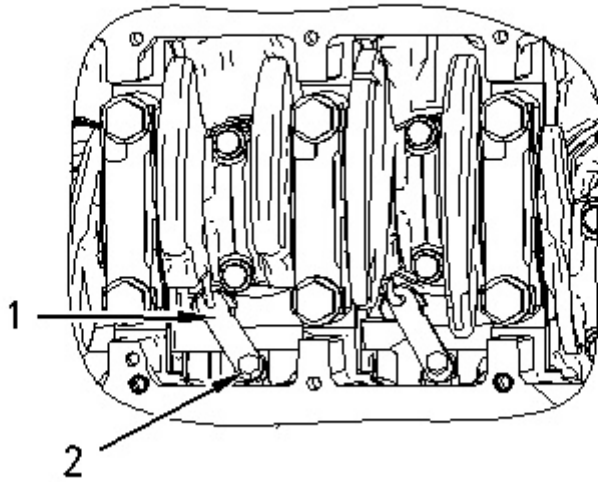

Illustration 2

g00987444

1. Position piston cooling jet (1) in the cylinder block. Install bolt (2). Tighten the bolt to a torque of 28 ± 7 N·m (21 ± 5 lb ft).

End By:

- a. Install the engine oil pan. Refer to Disassembly and Assembly, "Engine Oil Pan - Remove and Install".
-

Product: TRACK-TYPE TRACTOR

Model: D5N TRACK-TYPE TRACTOR AKD

Configuration: D5N XL, LGP TRACK-TYPE TRACTOR AKD00001-UP (MACHINE) POWERED BY 3126B Engine

Disassembly and Assembly 3126B Engines for Caterpillar Built Machines

Media Number -SEN9581-06

Publication Date -01/08/2018

Date Updated -17/08/2018

i02180392

Pistons and Connecting Rods - Remove

SMCS - 1225-011

Removal Procedure

Start By:

- a. Remove the cylinder head. Refer to Disassembly and Assembly, "Cylinder Head - Remove".
- b. Remove the engine oil pump. Refer to Disassembly and Assembly, "Engine Oil Pump - Remove".
- c. Remove the piston cooling jets. Refer to Disassembly and Assembly, "Piston Cooling Jets - Remove and Install".

NOTICE

Keep all parts clean from contaminants.

Contaminants may cause rapid wear and shortened component life.

NOTICE

The joint between the connecting rod and the connecting rod cap is produced by fracturing. The connecting rod assembly must be handled with care in order to avoid damage to the mating surfaces. The connecting rod assembly must be replaced if any damage occurs to the mating surfaces. New connecting rod assemblies come with the connecting rod caps bolted on the connecting rod.

Use only a soft jawed vise to hold the connecting rod assembly when removing the connecting rod cap bolts. Use only a soft faced hammer to tap the connecting rod cap when separating the connecting rod cap from the connecting rod.

Failure to use a soft jawed vise and a soft faced hammer may result in damage to the connecting rod assembly.

1. Turn the crankshaft until the connecting rod caps are at the bottom center.
-

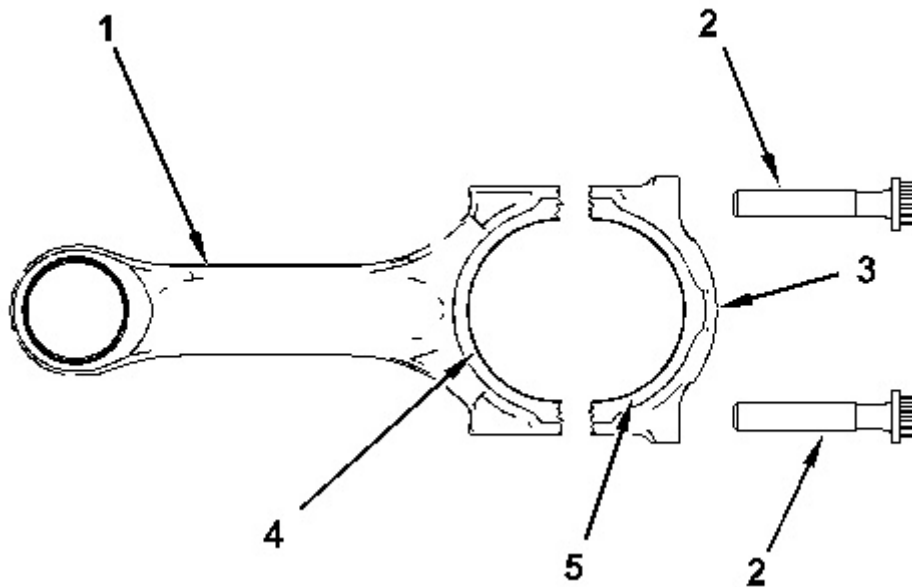

Illustration 1

g01062853

2. Inspect connecting rod (1) and connecting rod cap (3) for the proper identification mark. The connecting rod and the connecting rod cap should have an etched number on the side that is toward the right side of the engine. The number should match the cylinder number. Mark the connecting rod and the connecting rod cap, if necessary. Do not etch new markings on connecting rod or rod cap.
 3. Remove connecting rod bolts (2) and connecting rod cap (3).
 4. Remove the lower half of connecting rod bearing (5) from connecting rod cap (3).
 5. Push the piston and the connecting rod away from the crankshaft. Remove the upper half of connecting rod bearing (4) from connecting rod (1).
 6. Remove the piston and connecting rod (1) from the cylinder block.
-

Product: TRACK-TYPE TRACTOR

Model: D5N TRACK-TYPE TRACTOR AKD

Configuration: D5N XL, LGP TRACK-TYPE TRACTOR AKD00001-UP (MACHINE) POWERED BY 3126B Engine

Disassembly and Assembly 3126B Engines for Caterpillar Built Machines

Media Number -SEN9581-06

Publication Date -01/08/2018

Date Updated -17/08/2018

i01983492

Pistons and Connecting Rods - Disassemble

SMCS - 1225-015

Disassembly Procedure

Table 1

Required Tools			
Tool	Part Number	Part Description	Qty
A	1U-6683	Ring Expander	1
B	1P-1861	Retaining Ring Pliers	1

Start By:

- Remove the pistons and the connecting rods. Refer to Disassembly and Assembly, "Pistons and Connecting Rods - Remove".

NOTICE

Keep all parts clean from contaminants.

Contaminants may cause rapid wear and shortened component life.

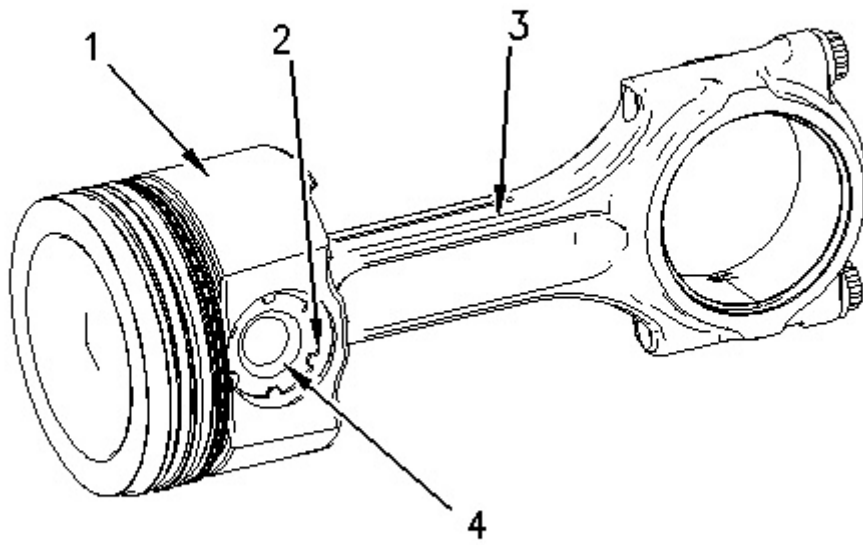

Illustration 1

g00988677

1. Use Tooling (B) to remove retaining ring (2). Remove piston pin (4) and separate piston (1) from connecting rod (3).
-

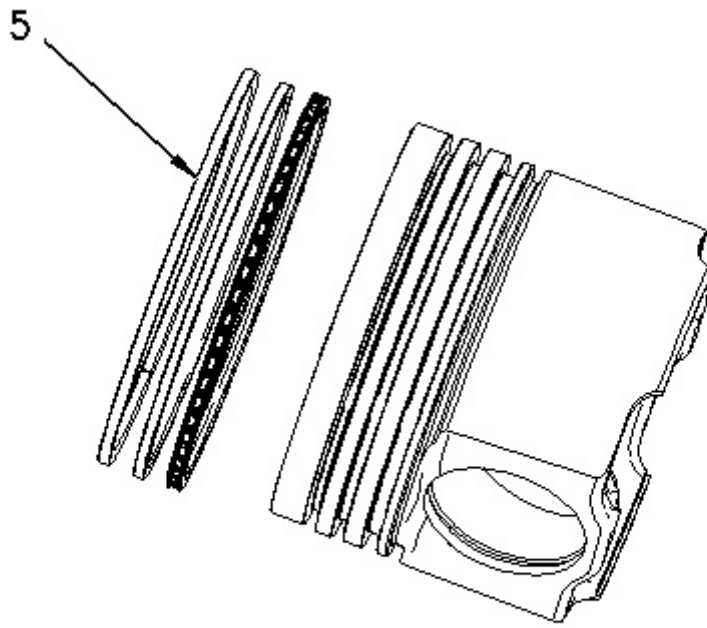

Illustration 2

g00988681

2. Use Tooling (A) to remove piston rings (5).
-

Thank you so much for reading.
Please click the “Buy Now!”
button below to download the
complete manual.



After you pay.

You can download the most
perfect and complete manual in
the world immediately.

Our support email:

ebooklibonline@outlook.com