

Product: TRACK-TYPE TRACTOR

Model: D6D SR TRACK-TYPE TRACTOR 7XF

Configuration: D6D SR TRACTOR / DIRECT DRIVE / 7XF00001-UP (MACHINE) POWERED BY 3306 ENGINE

Disassembly and Assembly 3304 & 3306 VEHICULAR ENGINE

Media Number -SEN2824-00

Publication Date -01/01/1983

Date Updated -11/10/2001

Fuel Injection Pump and Governor

SMCS - 1286-15; 1286-16

Remove Fuel Injection Pump And Governor

	Tools Needed	A	B	C
5P7307	Engine Turning Tool	1		
8S2264	Puller Group		1	
8B7560	Step Plate		1	
6F7031	Bolt		2	
5M2894	Washer		2	
FT1635	Timing Pin			1

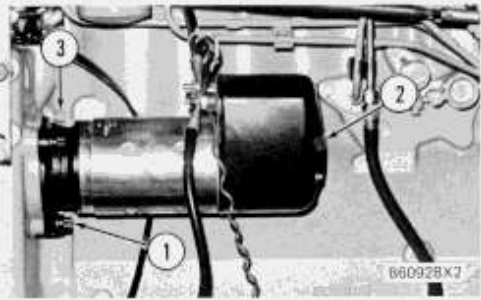

1. Disconnect the wires (not shown) from the starter. Fasten a hoist to the starter. Remove three bolts (1) and remove starter (2). Remove the gasket. The weight of the starter is 29 kg (64 lb.).

2. Remove plug (3) from the flywheel housing.

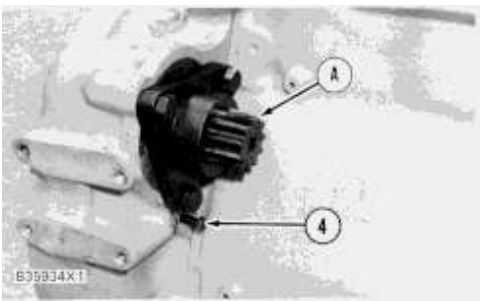

3. Install tooling (A) in the flywheel housing.

NOTE: No. 1 piston at top center (TC) on the compression stroke is the starting point for all timing procedures.

NOTE: The engine is seen from the flywheel end when direction of crankshaft rotation is given.

4. To find top center compression stroke for No. 1 piston, first turn the flywheel clockwise (opposite the direction of engine rotation) approximately 30 degrees. This procedure is to remove all play from the timing gears. Turn the flywheel counterclockwise until a 3/8"-16 NC bolt (4) can be installed in the flywheel through the hole in the flywheel housing. The No. 1 and No. 6 pistons are now at top center position.

NOTICE

If you go past the bolt hole you must start over with Step 2.

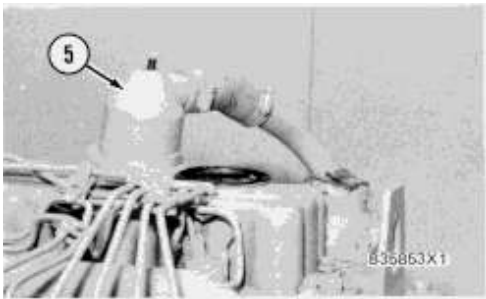

5. Remove breather (5) from the valve cover.

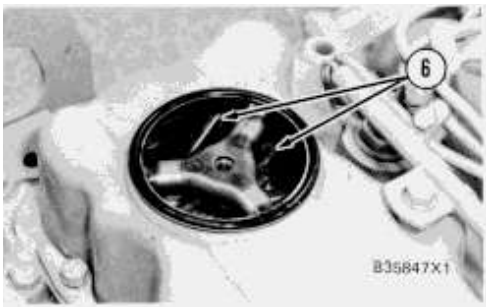

6. To see if the No. 1 piston is on the compression stroke, look at the valves of the No. 1 cylinder. The valves will be closed if No. 1 cylinder is on the compression stroke. You must be able to move both rocker arms (6) up and down with your hand.

7. If No. 1 piston is not on the compression stroke, remove the 3/8"-16 NC bolt (4) and turn the flywheel 360° counterclockwise. Install the 3/8" bolt as before. The No. 1 piston is now at top center (TC) on the compression stroke.

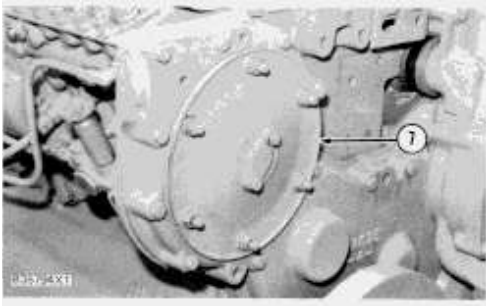

8. Remove cover (7) from the front of the timing gear cover.

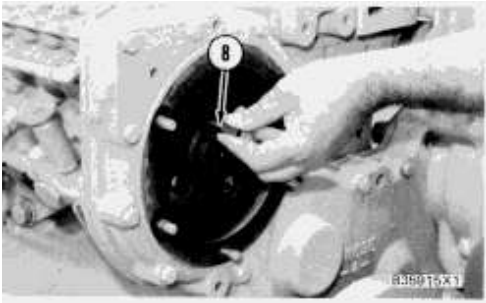

9. Install timing pin (8) [tool (C)] through the left top hole (as seen from the front of the engine) in the fuel injection pump gear and through the groove (slot) in the sleeve and into the hole in the adapter of the fuel injection pump. If the timing pin can not be installed at this time, install the timing pin after the fuel injection pump is removed.

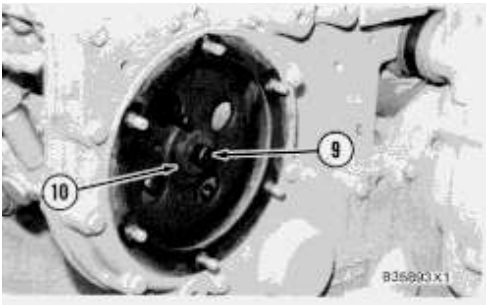

10. Loosen bolt (9) that holds the fuel injection pump gear to the sleeve approximately 3.2 mm (.125 in.).

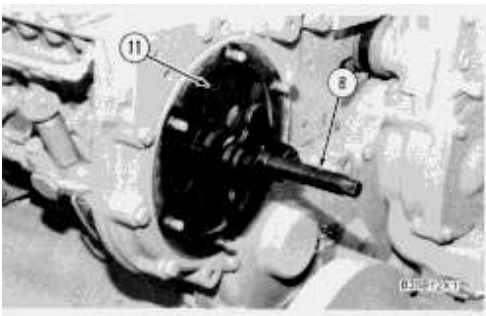

11. Install tooling (B) and loosen fuel injection pump gear (11) from the sleeve. Remove tooling (B). Remove bolt (9) and washer (10).

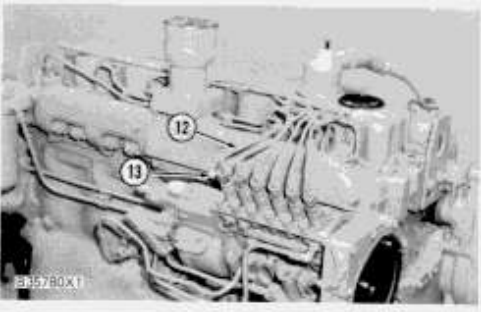

12. Disconnect the fuel return line (not shown) from bypass valve (13).

13. Remove fuel injection lines (12) from the engine. Put plugs or caps on all the openings.

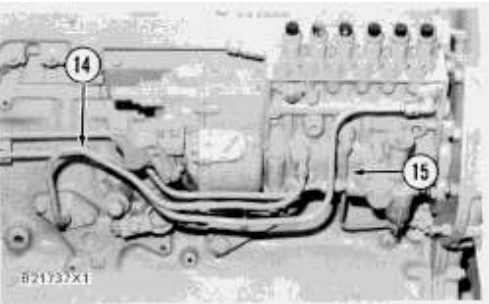

14. Remove oil supply line (15) and oil drain line (14).

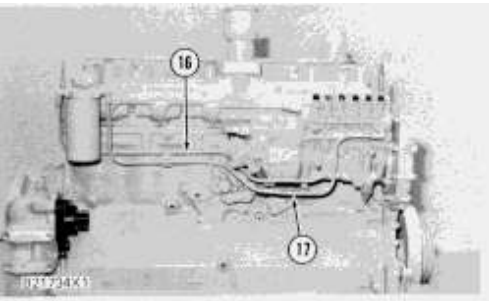

15. Remove fuel supply lines (16) and (17).

16. Put plugs or caps in the openings.

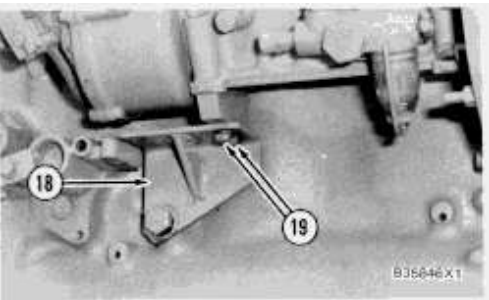

17. Remove bolts (19) that hold the fuel injection pump spacer to bracket (18).

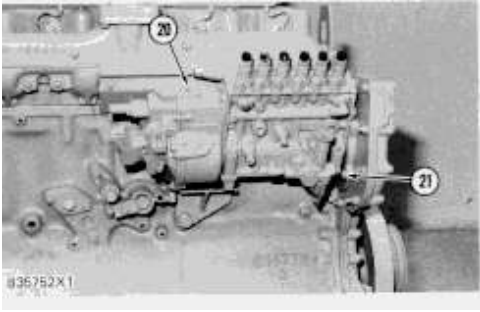

18. Remove three nuts (21) and remove fuel injection pump and governor (20). Remove the O-ring seal from the face of the fuel injection pump housing.

19. If the timing pin was not installed in Step 9, turn the pump as needed to make an alignment of the groove (slot) in the sleeve with the hole in the adapter and install the timing pin (tool C).

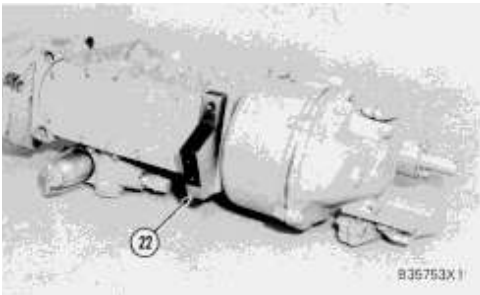

20. Remove spacer (22).

Install Fuel Injection Pump And Governor

	Tools Needed	A	B	C
FT1635	Timing Pin	1		
FT1644	Adapter- Torque		1	
5P3707	Engine Turning Tool			1

NOTICE

Make sure the timing pin [tool (A)] is installed through the groove (slot) in the sleeve and into the hole in the adapter so the fuel injection pump timing is correct.

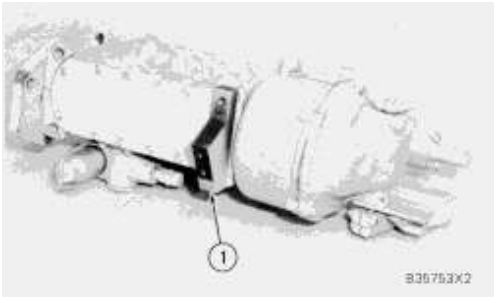

1. Install spacer (1) on the fuel injection pump housing.

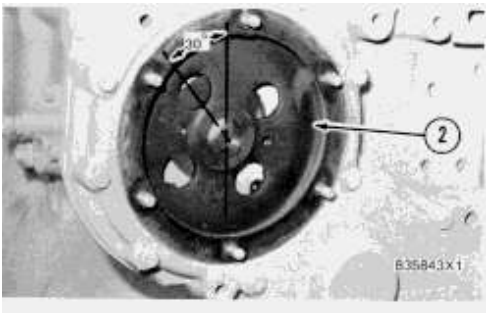

2. Make sure that the centerline of one of the holes in fuel injection pump gear (2) is 30° to the left of the vertical centerline of the fuel injection pump gear. This will permit the timing pin [tool (A)] to go through the hole in the fuel injection pump gear when the fuel injection pump and governor is installed.

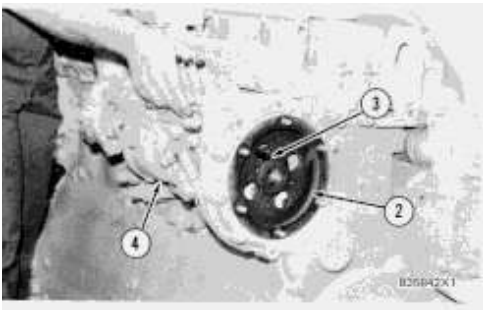

3. Install the O-ring seal on the face of the fuel injection pump housing. Put fuel injection pump housing and governor (4) in position on the engine and against the timing gear plate. Make sure timing pin (3) [tool (A)] goes through the hole in the fuel injection pump gear as shown.

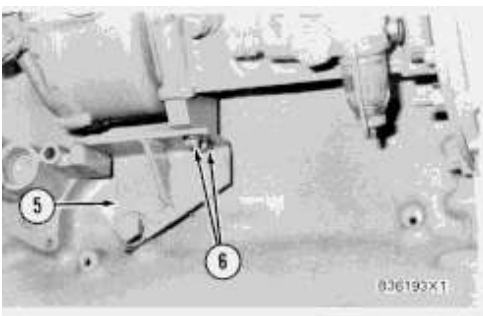

4. Install the three nuts that hold the fuel injection pump housing and governor to the timing plate. Install bolts (6) that hold the fuel injection pump spacer to bracket (5).

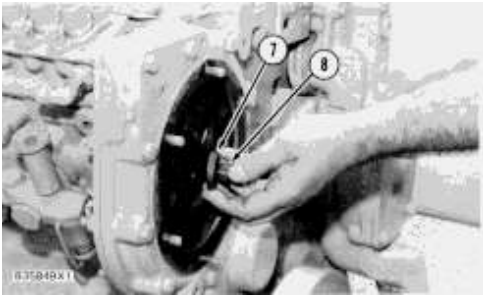

5. Install washer (7) and bolt (8) finger tight.

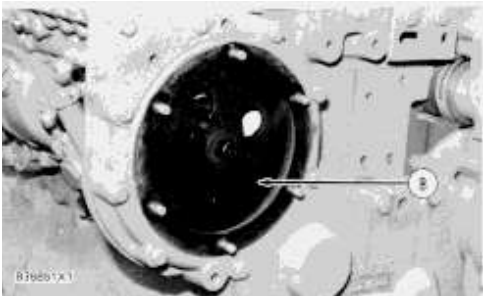

6. Install tooling (B) on the fuel injection pump gear as shown.

7. Put a torque wrench in tooling (B) with the wrench in line with the center of the fuel injection pump gear, and put a torque of 60 to 70 N·m (45 to 50 lb. ft.) on the fuel injection pump gear to remove the gear clearance (backlash). While this torque is held, tighten bolt (8) to a torque of 149 ± 7 N·m (110 ± 5 lb. ft.).



8. Remove timing pin (3) [tool (A)].

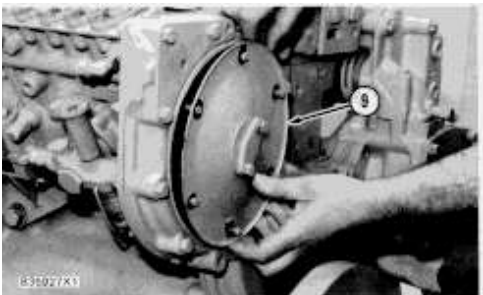

9. Put the gasket in place and install cover (9) on the front of the timing gear cover.

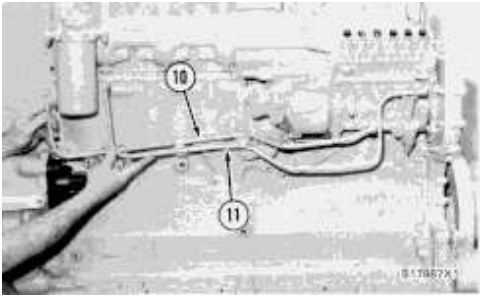

10. Install fuel supply lines (10) and (11).

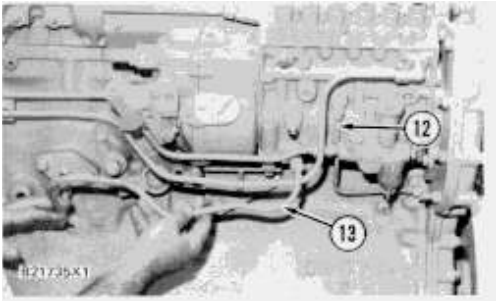

11. Install oil supply line (12) and oil drain line (13).

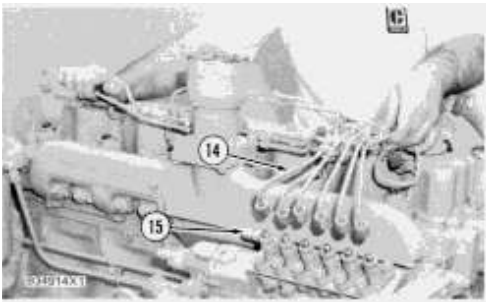

12. Install fuel injection lines (14) on the engine. Tighten the fuel line nuts to a torque of 40.7 ± 6.8 N·m (30 ± 5 lb. ft.).

13. Connect fuel return line (not shown) to bypass valve (15).

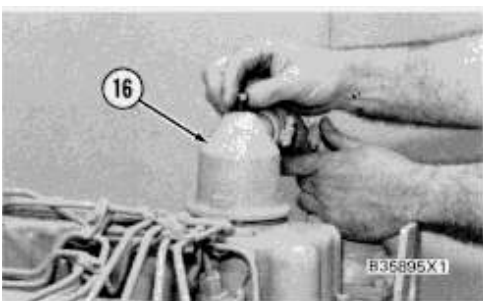

14. Install breather (16) on the valve cover.

15. Remove tooling (C) from the flywheel housing.

16. Remove bolt (17) from the flywheel.

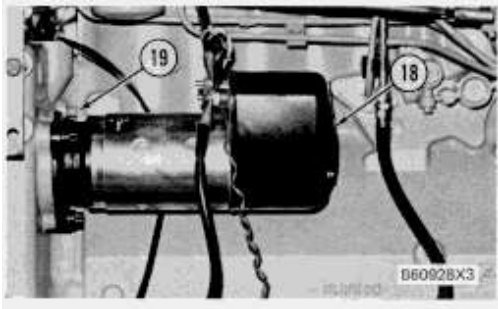

17. Install plug (19) in the flywheel housing.

18. Fasten a hoist to the starter. Put the gasket in place and install starter (18). Connect the wires (not shown) to the starter.

Disassemble Fuel Injection Pump And Governor

	Tools Needed	A	B	C	D	E	F	G	H	J	K	L	M	N	O	P	Q
2Y6847	Vise	1															
2Y6848	Clamp	1															
2Y6859	Pin Wrench		1														
2Y6865	Puller			1													
2Y6864	Pin Wrench				1												
2H3740	Bolt (1/4"-16 SAE x 1 1/4")					1											
2Y6858	Lifter Holder						6										
0L1732	Bolt (1/2"-20 SAE x 3")							1									
1B4205	Nut							1									
4B4280	Washer							1									
5P4168	Plate								1								
1P2320	Puller Assembly								1								
9S9152	Bearing Puller Attachment									1							
2Y6867	Wrench										1						
2Y6868	Tube Wrench											1					
FT1624	Puller												1				
2Y6850	Fixture													1			
2Y6852	Serrated Socket														1		
2Y6871	Bearing Tool															1	
2Y6872	Lifter Spring Compressor																1

start by:

a) remove fuel injection pump and governor.

NOTICE

Thoroughly clean the outside of the fuel injection pump and governor. Make sure all parts are kept with their respective parts. Do not mix parts. Do not put parts in a metal tray. Highly machined and polished parts can be damaged.

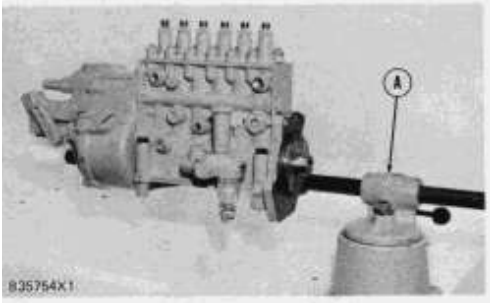

1. Install the fuel injection pump and governor on tooling (A) as shown.

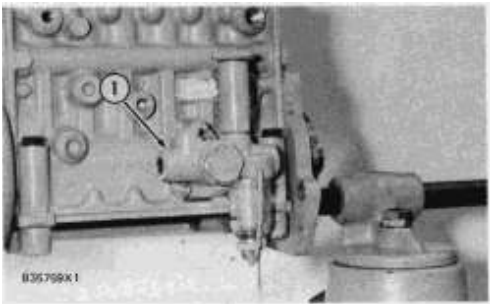

2. Remove fuel transfer pump (1) from the fuel injection pump housing.

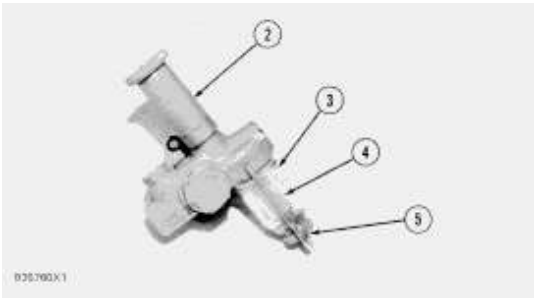

3. Remove hand priming pump (2). Remove the spring and valve from the housing.

4. Loosen clamp nut (5) and remove glass bowl (3), element (4) and the spring. Remove the gasket for the bowl from the housing.

NOTICE

Plug (6) holds a spring under compression.



5. Remove plug (6), gasket and spring from the housing.

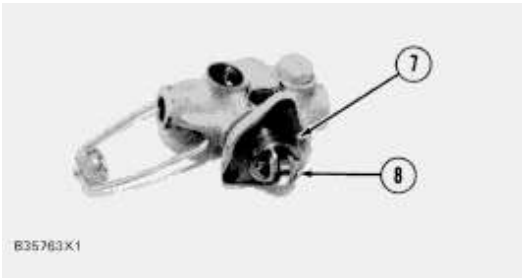

6. Remove ring (7) that holds the lifter in place. Remove lifter (8).

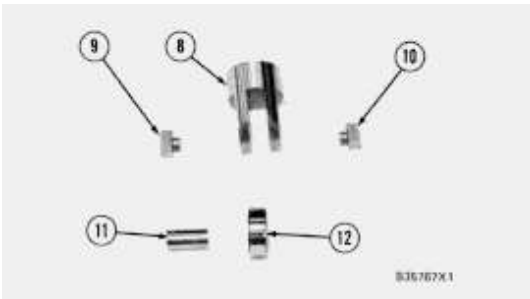

7. Remove pin (11) and roller (12) from lifter (8).

8. Remove guide pins (9) and (10) from roller (8).

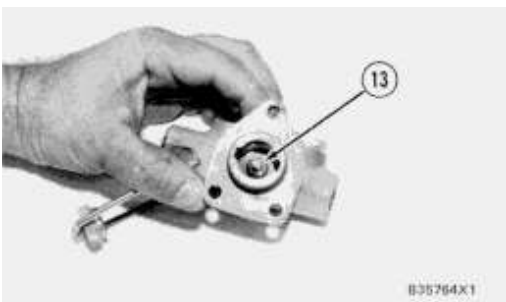

9. Push on rod (13) to remove rod (13) and the piston from the other side.

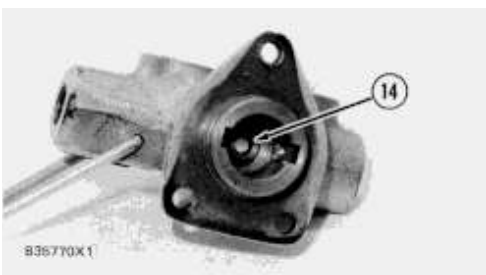

10. Remove seal (14).

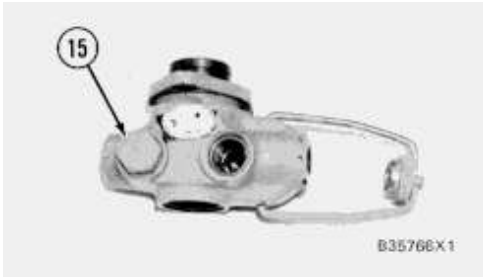

11. Remove plug (15), gasket, spring and valve from the housing.

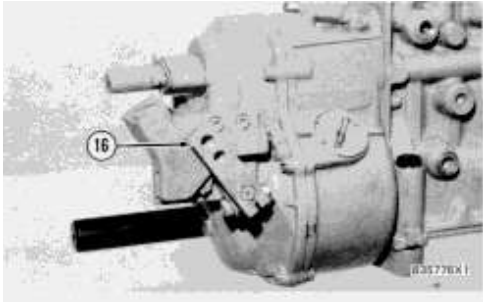

12. Remove lever (16) and the key from the shaft.

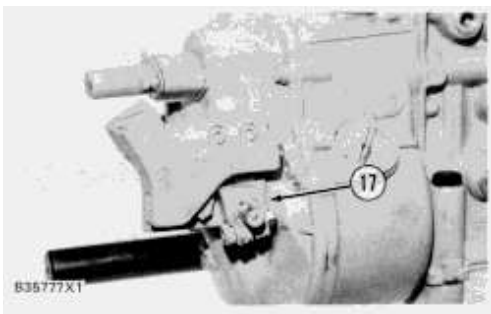

13. Remove lever (17) and the key from the shaft.

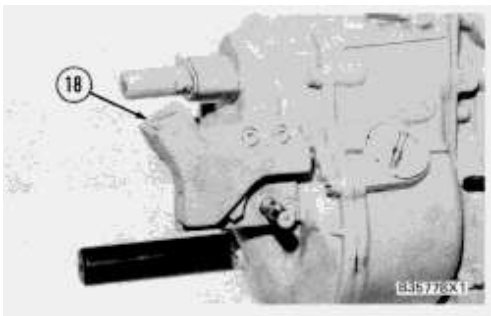

14. Remove detent mechanism (18) from the governor cover.

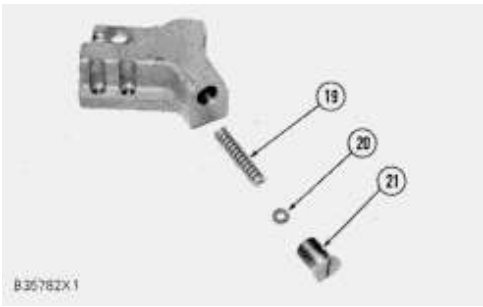

15. Remove screw (21), shim (20) and spring (19) from the detent mechanism.

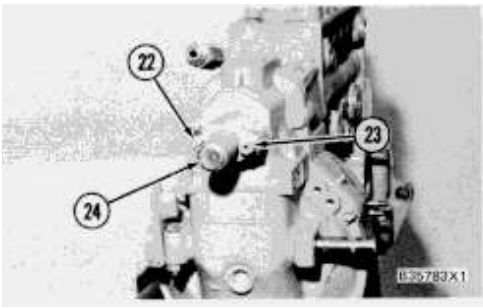

16. Remove bolt (23) with a punch and a hammer and remove screw (22) that holds cover (24) in place. Remove cover (24) and the gasket.

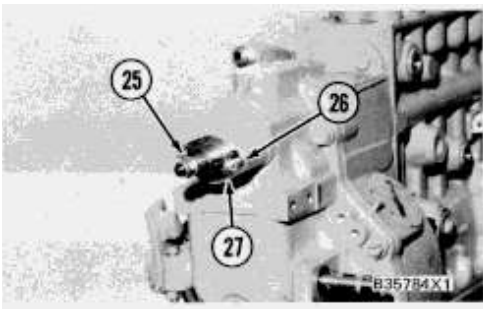

17. Remove studs (25) and (26). Remove rack setting group (27) and the gasket.

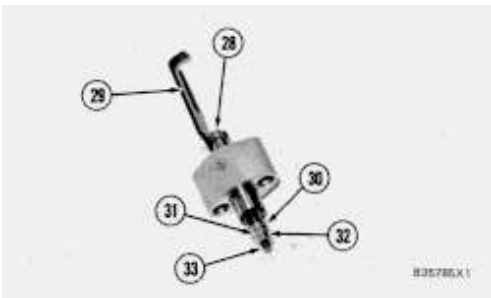

18. Remove nut (33), lock (32) (if so equipped), nut (31) and washer (30) from the rod.

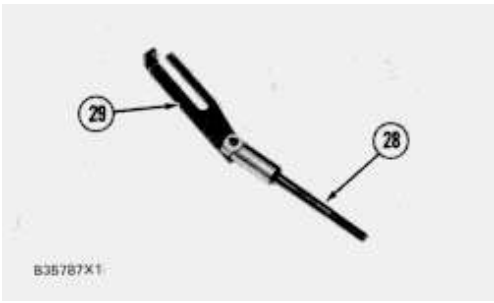

19. Remove rod (28) and strip (29) as a unit from the adapter.

20. Remove strip (29) from rod (28).

NOTICE

Ring (34) holds spring (36) under compression.

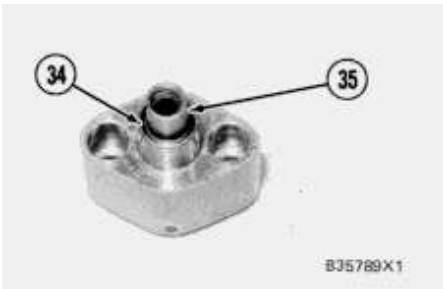

21. Remove ring (34) that holds bushing (35) in place. Remove bushing (35) and spring (36) from the adapter.

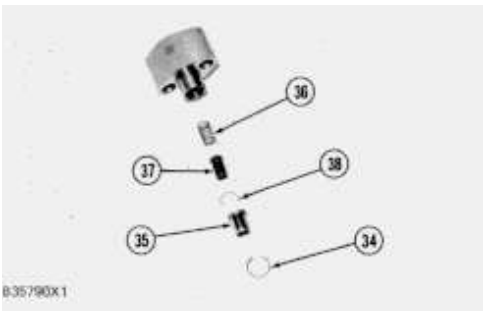

22. Remove ring (38) and remove sleeve (37) from bushing (35).

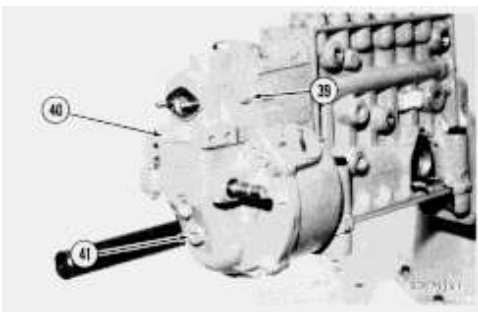

23. Remove guide screw (41) from the governor cover. Remove six screws (39) that hold the governor cover to the governor housing.

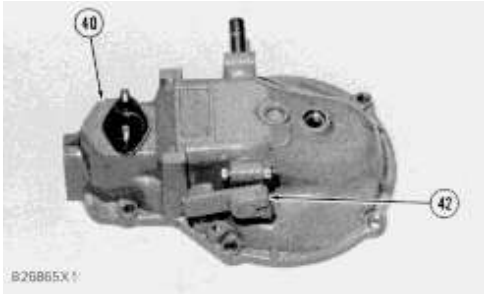

24. Pull the governor cover away from the governor housing and lift the governor cover up and remove governor cover (40).

NOTE: Guide block (50) is installed in the fulcrum lever. The governor cover must be lifted up to remove the guide block from the fulcrum lever.

25. Remove lever (42) and the key from the shaft.

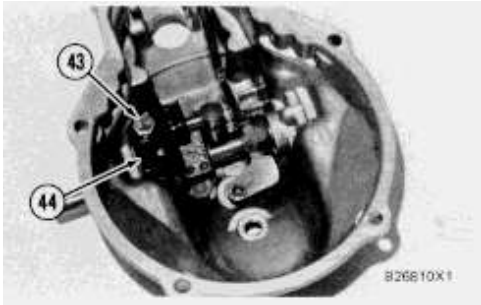

26. Remove bolt (43) that holds plate (44) to the governor cover. Remove the shims under the plate.

NOTICE

Be extra careful not to damage the governor cover when pins (46) are removed.

27. Use a punch and hammer and remove pins (46) from the lever and guide block.

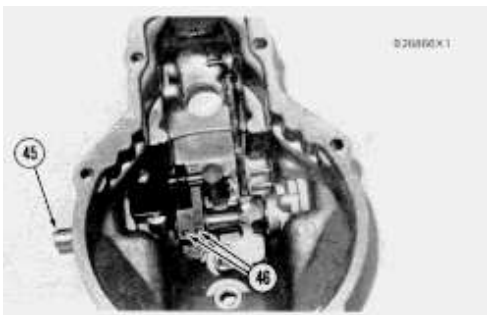

28. Remove shaft (45).

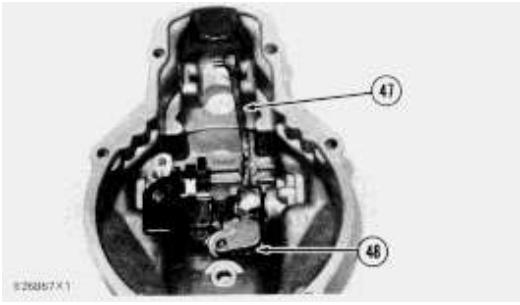

29. Remove lever (47) and spring (48) from the governor cover.

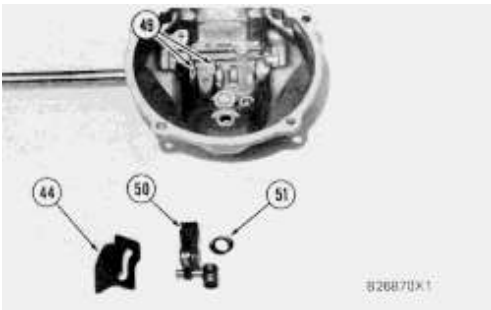

30. Remove shims (51), lever and guide block (50) and plate (44) from the governor cover. Remove washers (49).

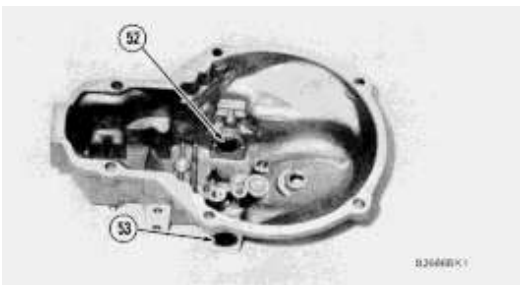

31. Remove bearing (52) and seal (53) from each side of the governor cover.

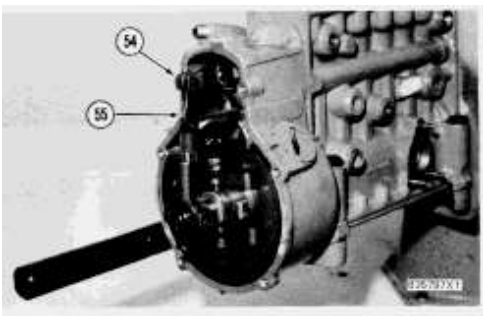

32. Disconnect fulcrum lever (55) from link (54). Use a rubber band to hold link (54) up.

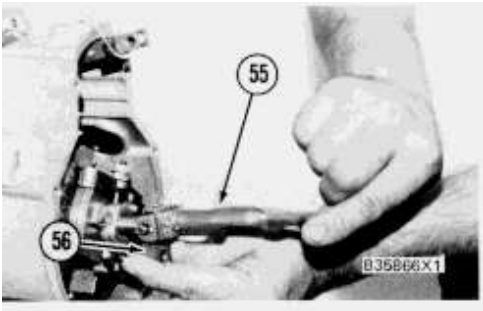

33. Move fulcrum lever (55) 90° from the governor housing as shown and remove fulcrum lever (55) and fork (56) from the shaft.

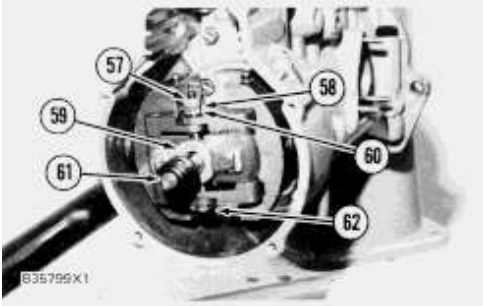

34. Bend lock (58) up. Remove nut (57), lock (58) and nut (60) from bolt (62).

35. Turn the fuel injection pump camshaft as needed so the head of bolt (62) is toward the top of the governor housing. Remove bolt (62).

36. Remove shaft (61).

37. Bend the locks up and remove the bolts that hold bushing (59) to the flyweights. Remove bushing (59).

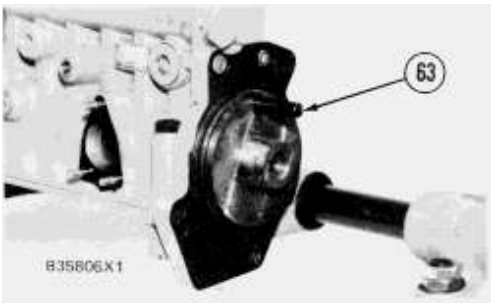

38. Turn the fuel injection pump camshaft until the hole in the sleeve is in alignment with the hole in the adapter. Install timing pin (63) so the fuel injection pump camshaft will not turn.

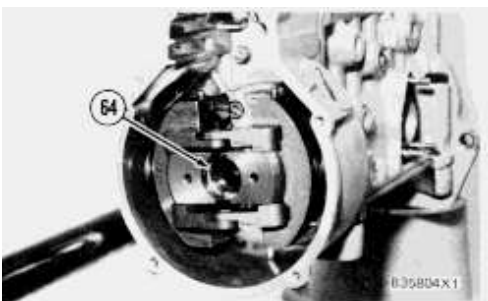

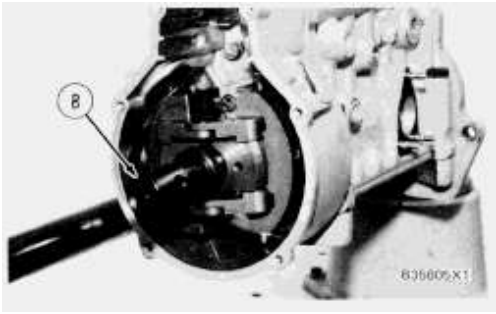

39. Use tooling (B) and remove nut (64) that holds the flyweights on the fuel injection pump camshaft. Remove the shim behind the nut.

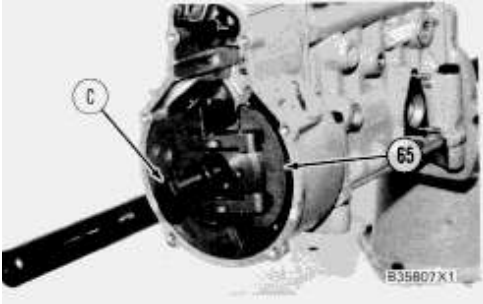

40. Use tooling (C) and remove flyweights (65) from the fuel injection pump camshaft.

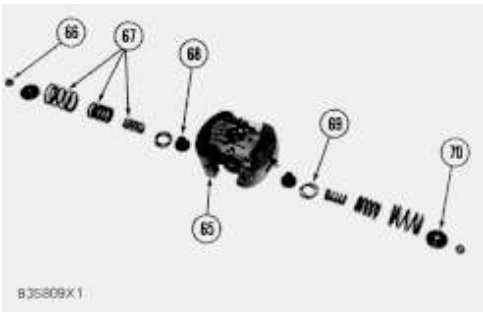

41. Use tool (D) and remove nut (66) from each side of the flyweight. Remove seat (70), spring (67), shims (69) and seat (68) from each side of flyweights (65).

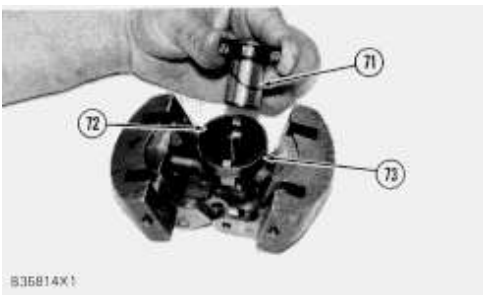

42. Remove puller (71) from ring (73). Remove dampers (72) from ring (73). Remove ring (73) from the flyweights.

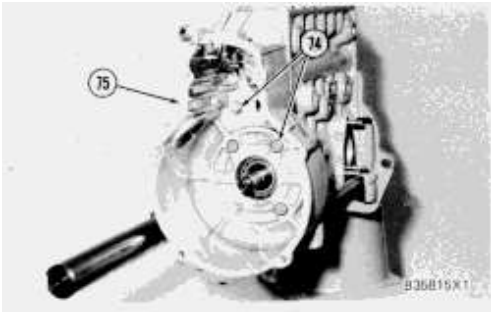

43. Remove eight bolts (74) that hold the governor housing to the fuel injection pump housing. Remove governor housing (75).

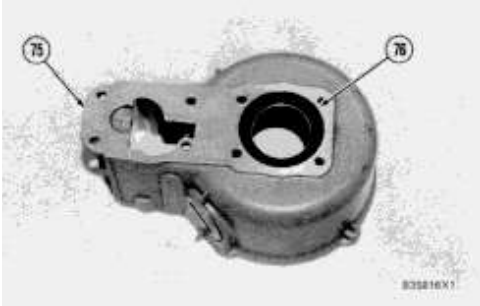

44. Remove shims (76) from governor housing (75).

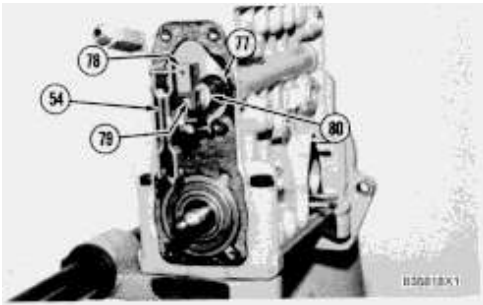

45. Remove two screws (79) that hold block (78) to the bar (rack). Remove block (78) and link (54) as a unit.

46. Remove seat (80) and spring (77) from the bar (rack).

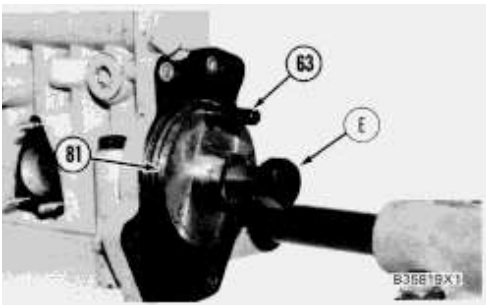

47. Use tool (E) and remove sleeve (81). Remove timing pin (63).

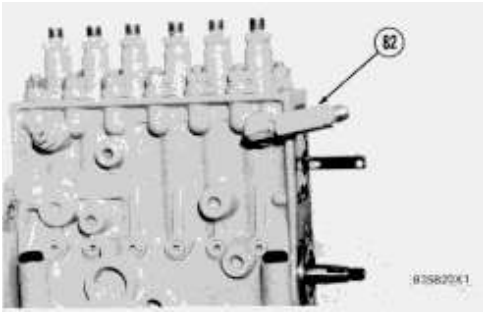

48. Remove fuel bypass valve (82) from the fuel injection pump housing.

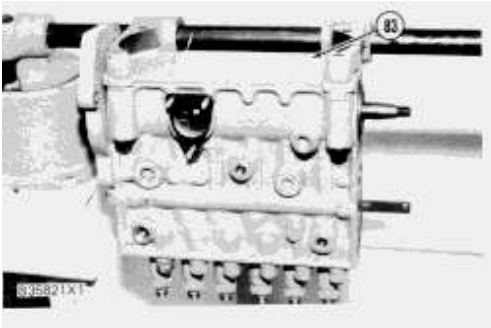

49. Turn the fuel injection pump housing over as shown. Remove cover (83) and gasket from the bottom of the fuel injection pump housing.

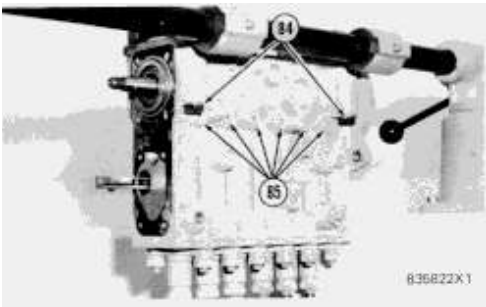

50. Remove mounting bolts (84). Remove six plugs (85) from the side of the fuel injection pump housing.

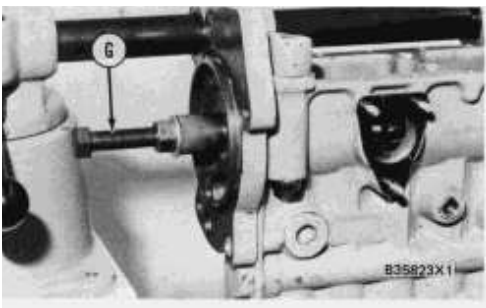

51. Install tooling (G) in the end of the fuel injection pump camshaft. Tooling (G) will be used to turn the fuel injection pump camshaft.

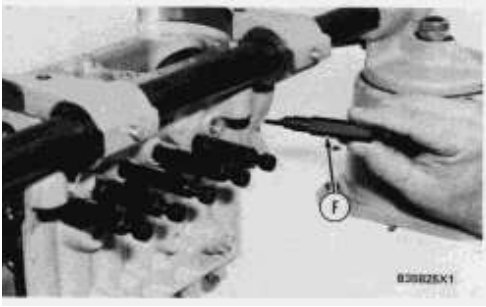

52. Turn the fuel injection pump camshaft until the lifter is as far down in the bore as possible. Install tooling (F) with the flat side toward the lifter. Tooling (F) will hold the lifter down when the fuel injection pump camshaft is removed. Do the other lifters the same way.

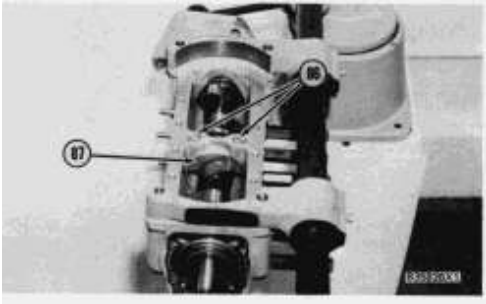

53. Remove bolts (86) that hold center bearing (87) in place.

54. Remove tooling (G).

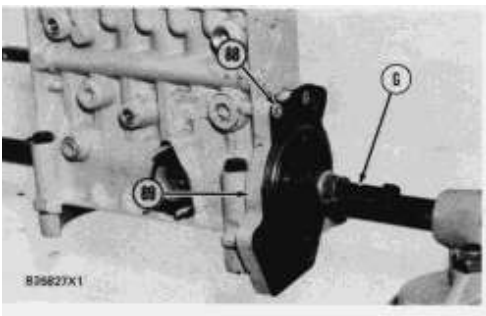

55. Remove bolts (88) that hold adapter (89) to the fuel injection pump housing.

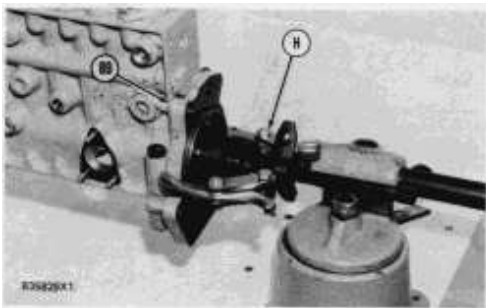

56. Use tooling (H) and removed adapter (89).

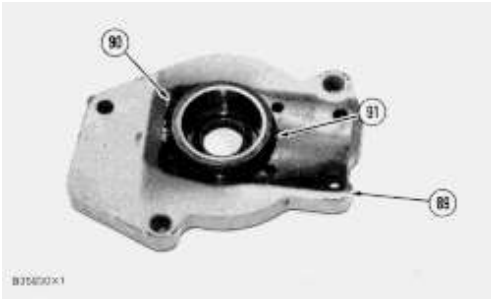

57. Remove O-ring seal (91) and shims (90) from adapter (89).

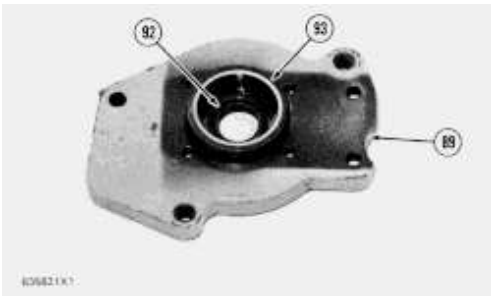

58. Remove lip type seal (92) and bearing cup (93) from adapter (89).

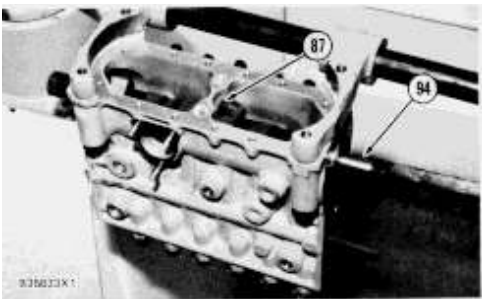

59. Pull fuel injection pump camshaft (94) forward just enough to remove center bearing (87). Remove center bearing (87). Remove fuel injection pump camshaft (94).

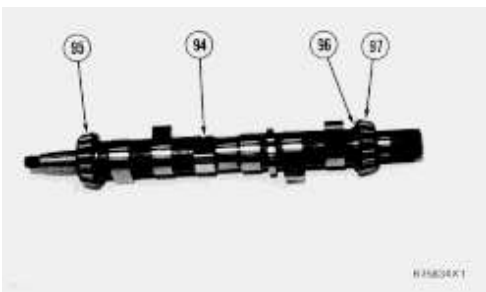

60. Remove bearing cones (95) and (97) from fuel injection pump camshaft (94) with tool (J) and a press. Remove shims (96) from behind bearing cone (97).



61. Use tool (Q) and push down on the lifters and remove tooling (F) from the fuel injection pump housing.

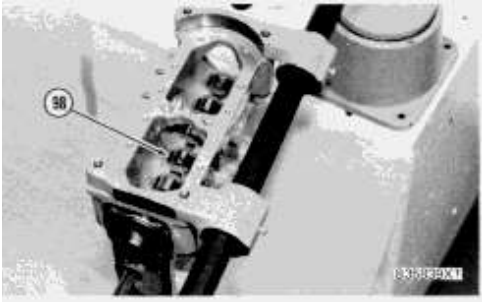

62. Remove lifters (98) from the fuel injection pump housing.

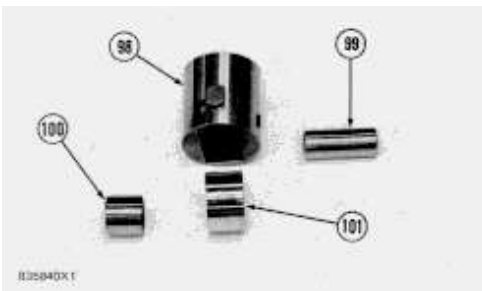

63. Remove pins (99) that hold rollers (101) and bushings (100) in the lifters. Remove rollers (101) and bushings (100) from lifters (98).

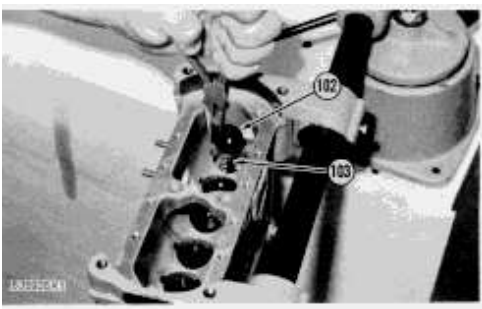

64. Use a pair of pliers as shown and remove lower spring seats (102) and plungers (103) from the fuel injection pump housing.

NOTICE

Position the bar (rack) so the balls on the control sleeves are in alignment with the grooves in the fuel injection pump housing.

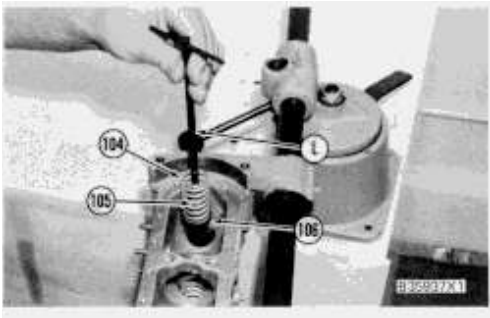

65. Use tool (L) and remove springs (104), control sleeves (105) and upper spring seats (106) from the fuel injection pump housing.

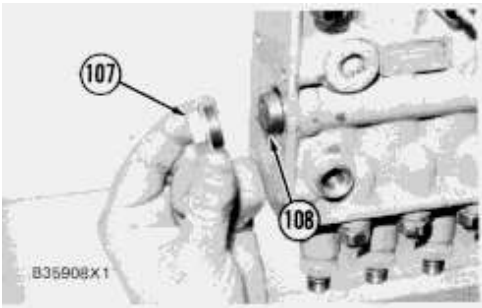

66. Remove plug (107) and gasket from the fuel injection pump housing.

67. Remove guide (108).

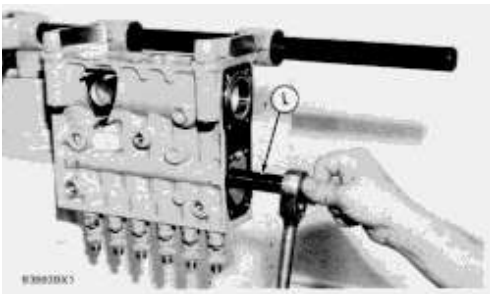

68. Use tool (L) and remove the ring from the fuel injection pump housing that holds the bar (rack) in place.

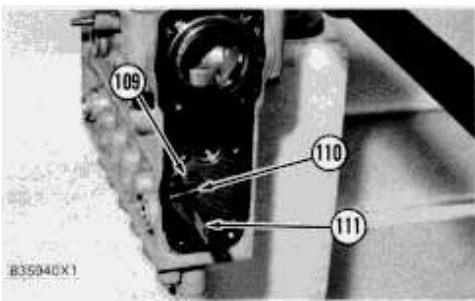

69. Remove pin (110) from bar (rack) (111). Remove bar (rack) (111).

70. If a replacement is needed, use a long brass punch and a hammer and remove guide (109) from the fuel injection pump housing.

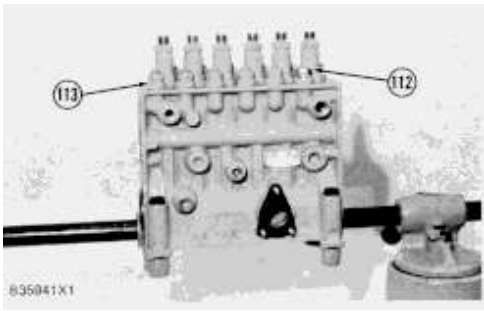

71. Remove barrel housing flange nuts (112) and washers (113) that hold the barrel assemblies in the fuel injection pump housing.

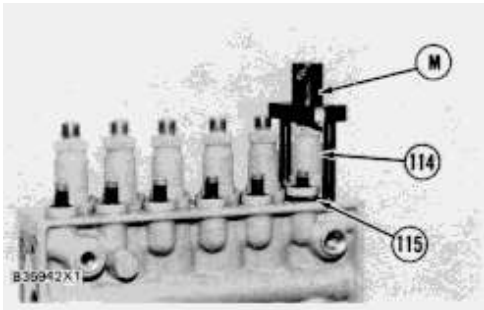

72. Use tool (M) and remove barrel assemblies (114). Remove shims (115).

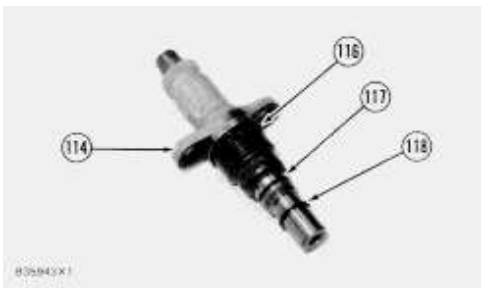

73. Remove O-ring seals (116), (117) and (118) from barrel assembly (114).

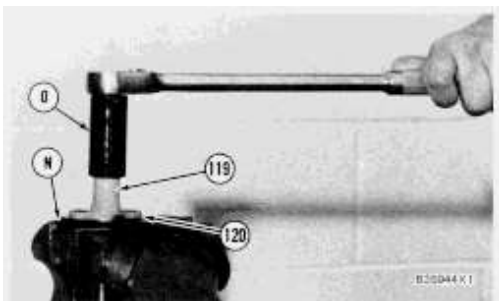

74. Use tool (N) to hold the barrel assembly and loosen bonnet (119) from barrel (120) with tool (O).

Thank you so much for reading.
Please click the “Buy Now!”
button below to download the
complete manual.



After you pay.

You can download the most
perfect and complete manual in
the world immediately.

Our support email:

ebooklibonline@outlook.com