

Product: TRACK-TYPE TRACTOR

Model: D6G2 XL TRACK-TYPE TRACTOR C6G

Configuration: D6G2 XL TRACK-TYPE TRACTOR C6G01000-UP (MACHINE) POWERED BY 3306 Engine

Disassembly and Assembly D6G Series II Track-Type Tractor Power Train

Media Number -KENR6344-02

Publication Date -01/09/2018

Date Updated -14/09/2018

i02606590

Transmission and Transfer Gears - Disassemble

SMCS - 3002-015; 3030-015; 3159-015

Disassembly Procedure

Table 1

Required Tooling			
Tool	Part Number	Part Description	Qty
A	1P-2420	Repair Stand	1
B	1P-3075	Puller Assembly	1
	8B-7548	Puller Assembly	1
	8B-7551	Bearing Puller Attachment	1
	8B-7549	Leg	2
C	8B-7550	Leg	2
	8B-7555	Adapter	2
	8H-0684	Ratchet Box Wrench	1
	8B-7560	Step Plate	1
	8B-7548	Puller Assembly	1
D	8B-7551	Bearing Puller Attachment	1
	8B-7550	Leg	2
	8H-0684	Ratchet Box Wrench	1
	8B-7560	Step Plate	1
E	FT-0833	Clamp	2

F	8B-7548	Puller Assembly	1
	8B-7550	Leg	2
	8H-0684	Ratchet Box Wrench	1
	8H-0663	Bearing Puller Attachment	1
	9S-9155	Spacer	1
G	8B-7548	Puller Assembly	1
	8B-7550	Leg	2
	8H-0684	Ratchet Box Wrench	1
	8H-0663	Bearing Puller Attachment	1
	1P-0492	Driver Plate	1
H	1P-7407	Eyebolt	2
J	1P-7405	Eyebolt	1
K	-	Forcing Screws 1/2 inch - 13 NC	3
L	-	Forcing Screws 1/2 inch - 13 NC	3
M	-	Screw 6 - 40	1

Start By:

- a. Remove the transmission and transfer gears. Refer to Disassembly and Assembly, "Transmission and Transfer Gears - Remove".

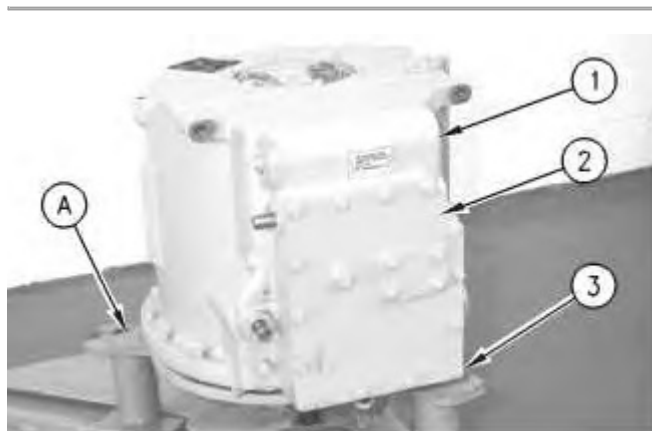

Illustration 1

g00317917

1. Position transmission (1) on Tooling (A). Remove bolts (3) and cover (2).

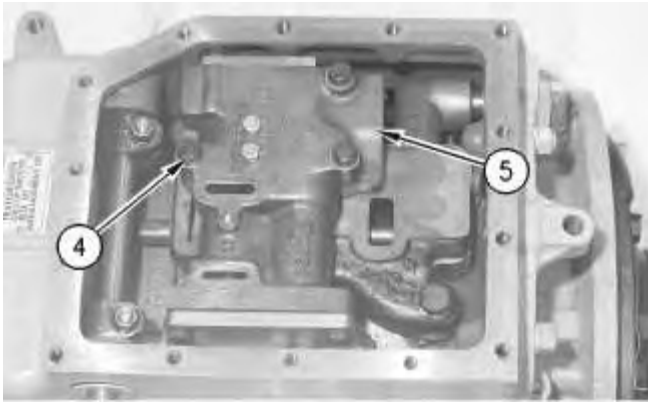

Illustration 2

g00317918

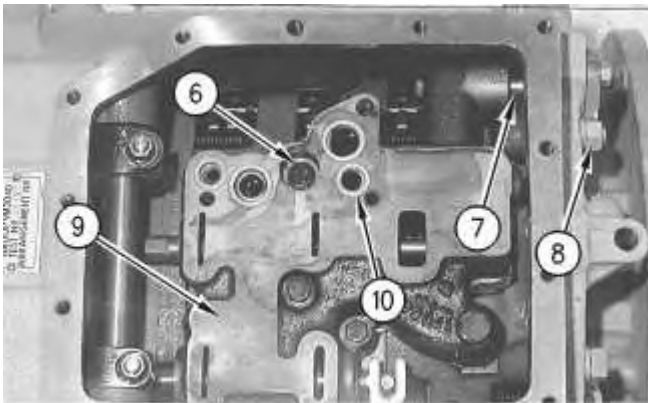

Illustration 3

g00318183

2. Remove the transmission hydraulic control:
 - a. Remove bolts (4).
 - b. Remove pressure control valve (5).
 - c. Remove cover (8). Remove tube (7) and the O-ring seals.
 - d. Remove bolts (6). Remove valve assembly (9).
 - e. Remove O-ring seals (10).

Note: For the disassembly procedure of the transmission hydraulic control valves, refer to Disassembly and Assembly, "Transmission Hydraulic Control - Disassemble".

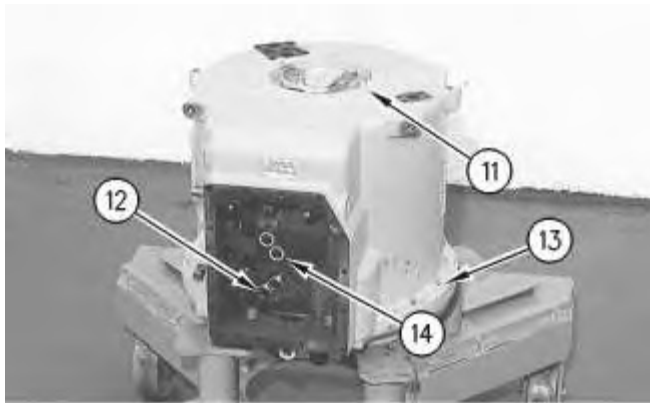

Illustration 4

g00318185

3. Remove all sleeves (12) that were not removed with valve assemblies. Remove O-ring seals (14).
4. Remove bolts (11).
5. Remove bolts (13).

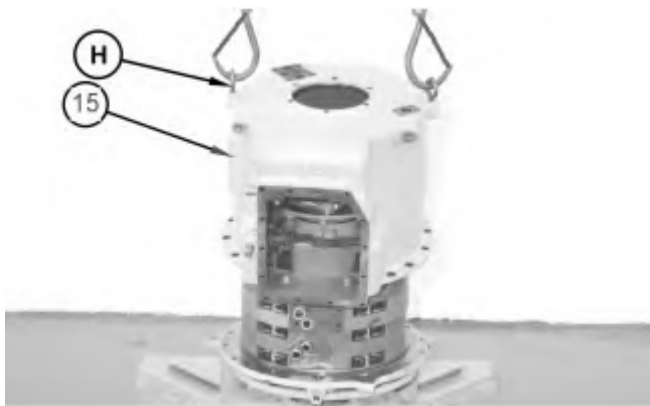

Illustration 5

g01304987

6. Install Tooling (H) and a suitable lifting device to transmission case (15). The weight of transmission case (15) is approximately 63 kg (140 lb). Remove transmission case (15).

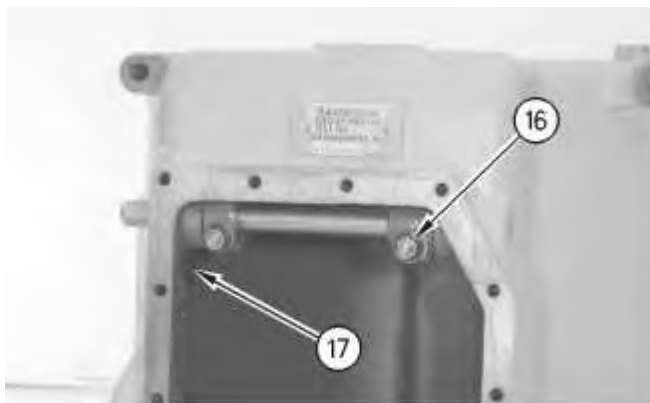

Illustration 6

g00318190

WARNING

Personal injury can result from being struck by parts propelled by a released spring force.

Make sure to wear all necessary protective equipment.

Follow the recommended procedure and use all recommended tooling to release the spring force.

7. Remove spring (17). Remove nuts (16) and the bolts.

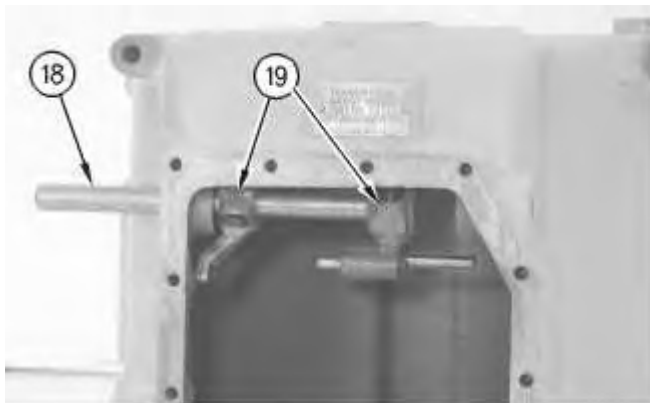

Illustration 7

g00318191

8. Remove shaft (18) and levers (19).

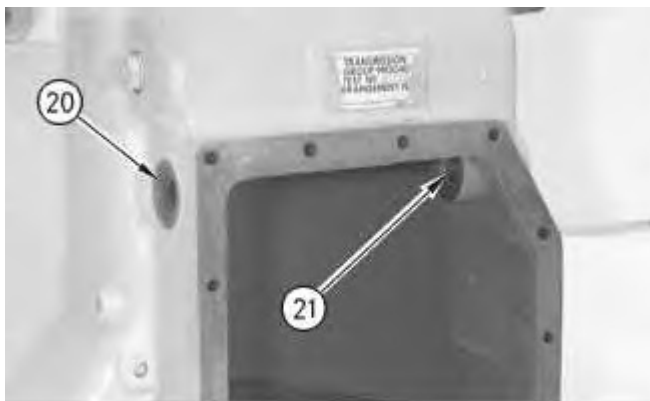

Illustration 8

g00318203

9. Remove seal (20) and needle bearing (21).
-

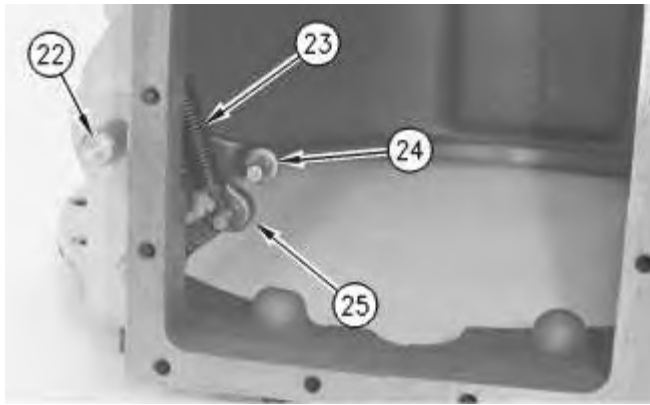

Illustration 9

g00318204

 **WARNING**

Personal injury can result from being struck by parts propelled by a released spring force.

Make sure to wear all necessary protective equipment.

Follow the recommended procedure and use all recommended tooling to release the spring force.

-
10. Remove spring (23), lever (24), shaft (22) and lever (25).

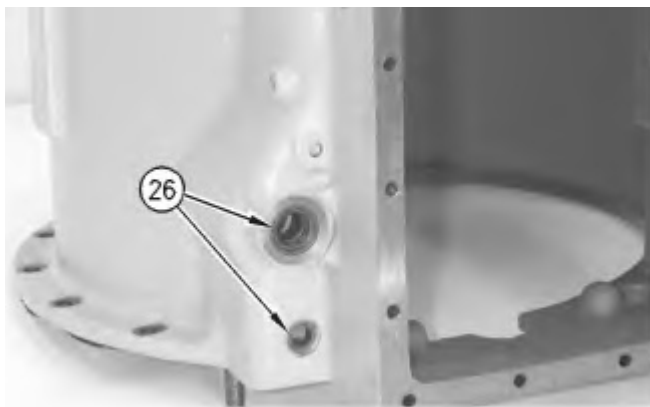

Illustration 10

g00318243

-
11. Remove seals (26) and the needle bearing.
-



Illustration 11

g00318263

12. Remove bolts (27) and locks (28).

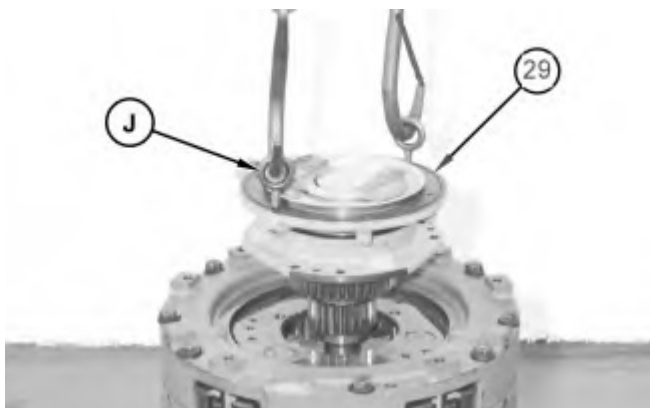

Illustration 12

g01304989

13. Install Tooling (J) and a suitable lifting device to bearing cage (29). The weight of bearing cage (29) and the input shaft is approximately 27 kg (60 lb). Remove bearing cage (29) and the input shaft as a unit.

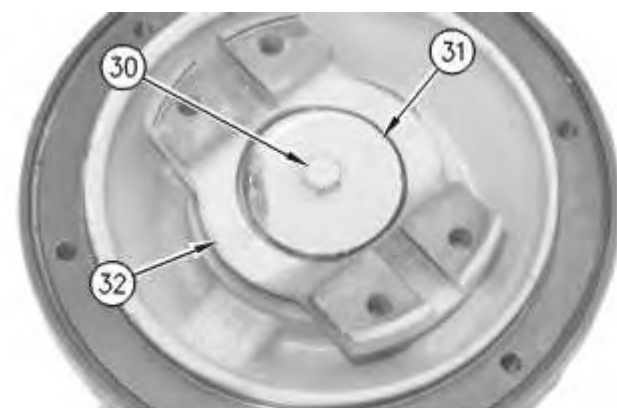

Illustration 13

g00318265

14. Remove bolt (30). Remove washer (31) and flange (32).

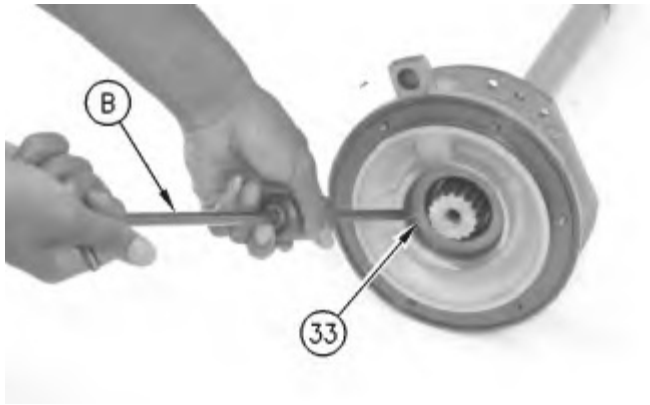

Illustration 14

g00318303

15. Use Tooling (B) in order to remove seal (33).
16. Remove the retainer ring that holds the bearing cage on the input shaft. Remove the bearing cage from the input shaft.



Illustration 15

g00318623

17. Remove seal rings (34).

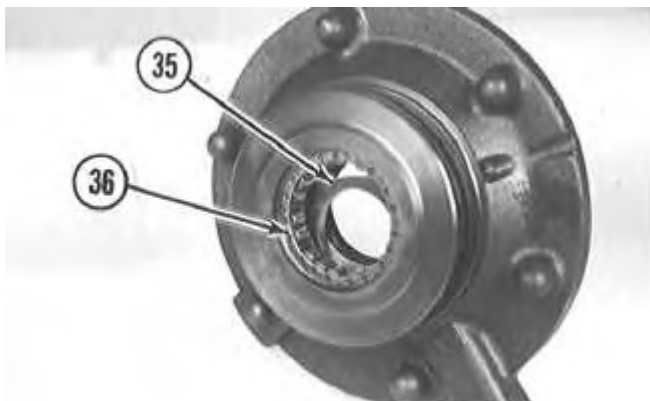

Illustration 16

g00318856

18. Remove the two retainer rings. There is a retainer ring on the top and the bottom of the cage. The retainer rings hold the bearing (36) in the cage.
19. Remove spacer (35) and bearing (36).

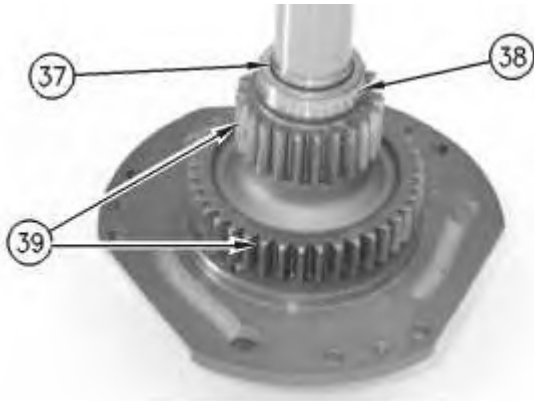

Illustration 17

g00318304

20. Remove retaining ring (37) that holds the bearing race (38) and gears (39) on the shaft.

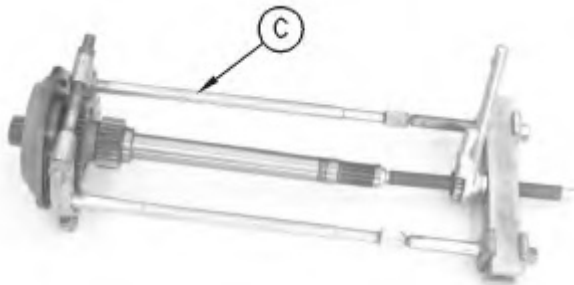

Illustration 18

g00318305

21. Use Tooling (C) to remove two gears (39) and race (38).



Illustration 19

g00318308

22. Remove the bearing cage from the shaft with a soft hammer.



Illustration 20

g00318309

23. Remove ring (40).

24. Remove bearing (41).

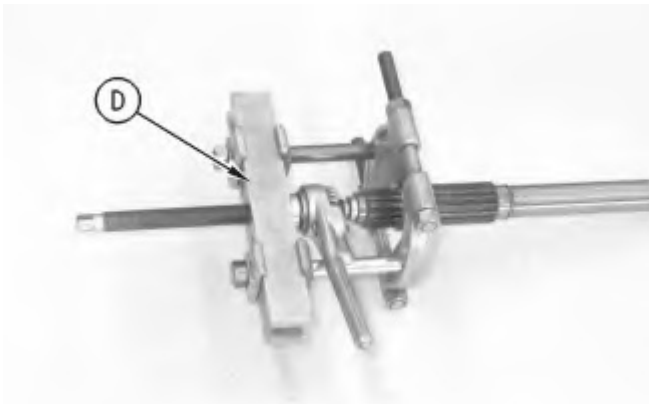

Illustration 21

g00318385

25. Use Tooling (D) and remove the bearing inner race from the shaft.

Note: Put an identification on each of the clutch housings. This should be done in order to identify the sequence and the location of the clutch housings. The housings must be installed in the same location. The housings must be installed in a reverse sequence. Do not mix the disc assemblies or the plate. Keep these parts with the respective clutch housing.



Illustration 22

g00318386

! WARNING

Personal injury can result from being struck by parts propelled by a released spring force.

Make sure to wear all necessary protective equipment.

Follow the recommended procedure and use all recommended tooling to release the spring force.

26. Remove bolts (42).

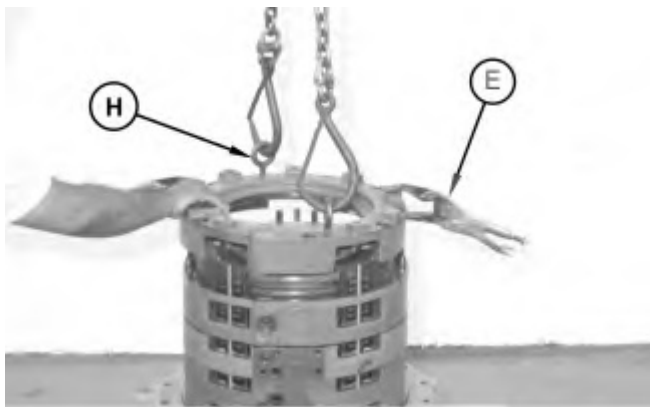

Illustration 23

g01304996

27. Install Tooling (E) in order to keep the No. 1 clutch piston in the No. 1 clutch housing. Remove the other three bolts.
28. Install Tooling (H) and a suitable lifting device to the No. 1 clutch housing. The weight of the No. 1 clutch housing and the piston is approximately 25 kg (55 lb). Remove the No. 1 clutch housing and the No. 1 piston as a unit.



Illustration 24

g00318388

29. Turn the No. 1 clutch housing upside-down. Remove Tooling (E). Remove piston (43). Remove the ring seals from the piston and No. 1 clutch housing.

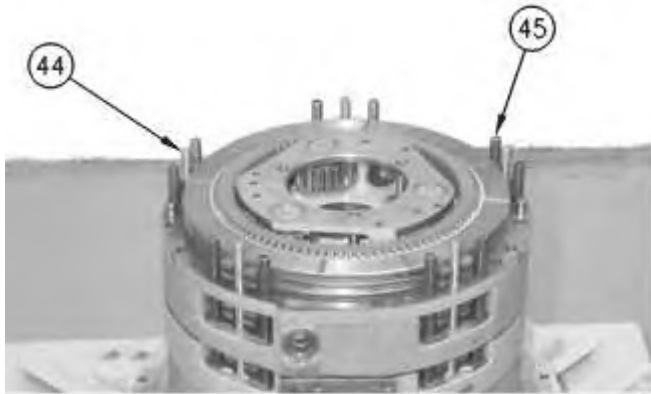

Illustration 25

g00318389

30. Remove five dowels (44) and ten springs (45).

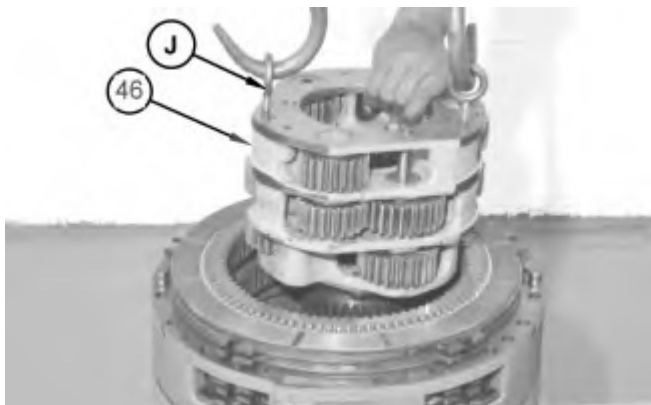

Illustration 26

g01305002

31. Install Tooling (J) and a suitable lifting device to No. 1 carrier (46). The weight of No. 1 carrier (46) is approximately 23 kg (50 lb). Remove No. 1 carrier (46).
-

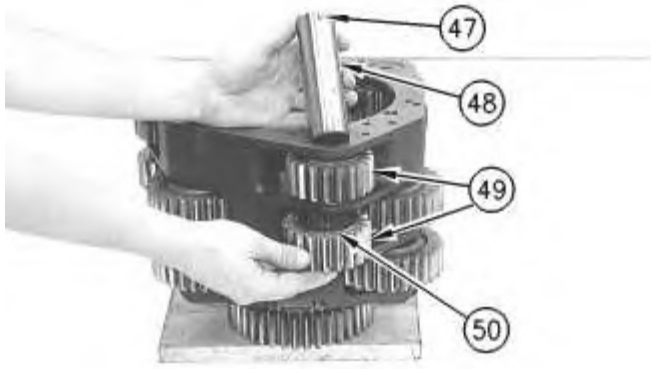

Illustration 27

g00318626

Note: Do not lose balls (47). When shafts (48) are removed, balls (47) can fall out of the shafts.

32. Remove shafts (48), gears (49) and washers (50) from No. 1 carrier. There is a washer on the top and the bottom of the gears. Remove the needle bearings from the gears.

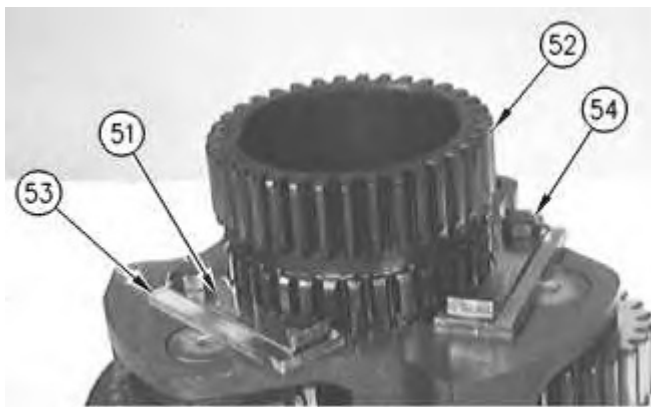

Illustration 28

g00318684

33. Remove bolts (54), locks (51) and plates (53). Remove gear (52) from the No. 1 carrier.

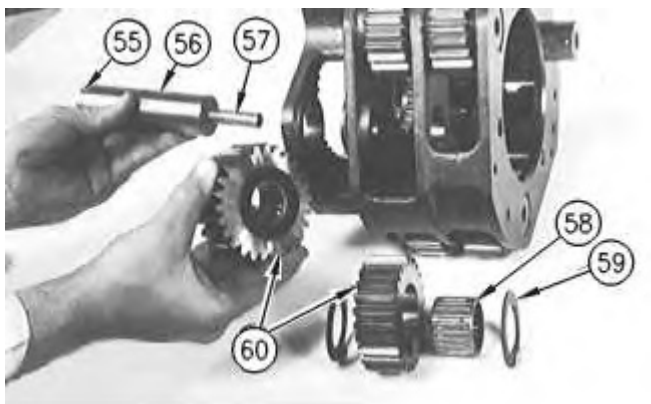

Illustration 29

g00318686

Note: Do not lose balls (55). When shafts (56) are removed, balls (55) can fall out of the shafts.

34. Position the No. 1 carrier on the side. Remove shafts (56) and tubes (57).
35. Remove gears (60) and washers (59).
36. Remove needle bearings (58).

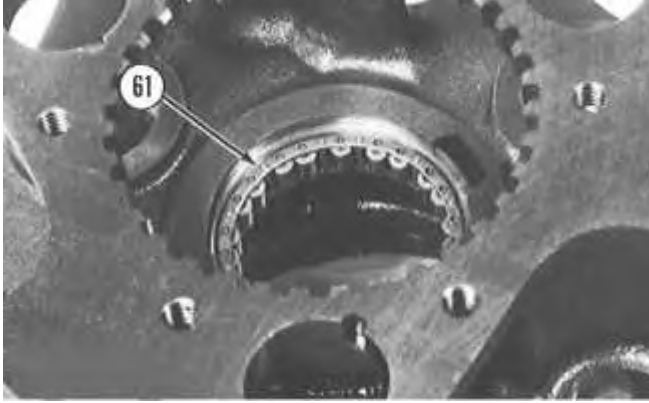

Illustration 30

g00318687

37. Remove needle bearing (61) from No. 1 carrier.

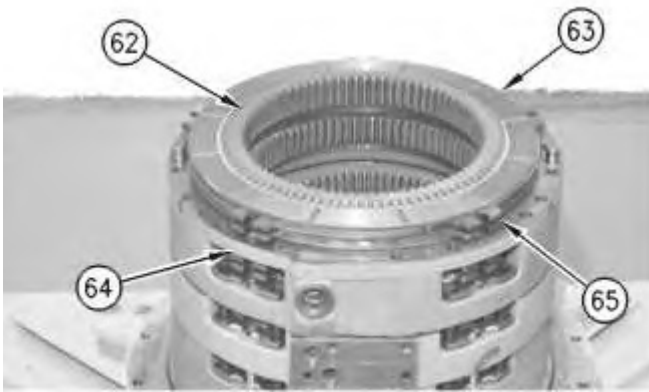

Illustration 31

g00318398

38. Remove ring gear (62), three clutch discs (63), two plates (65), and plate (64).
-

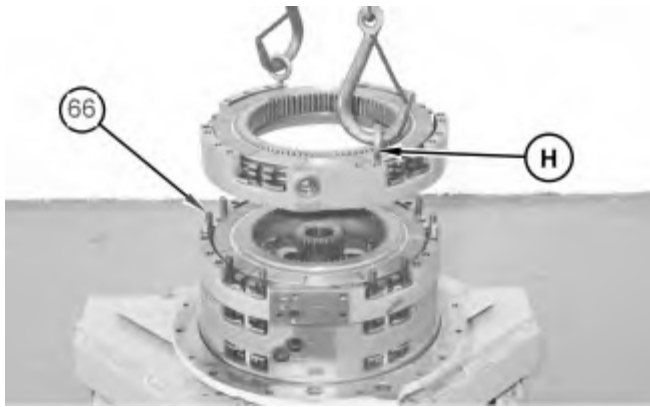

Illustration 32

g01307705

39. Install Tooling (H) and a suitable lifting device in No. 2 clutch housing. The weight of the No. 2 clutch is approximately 25 kg (55 lb). Remove the No. 2 clutch.

40. Remove springs (66).

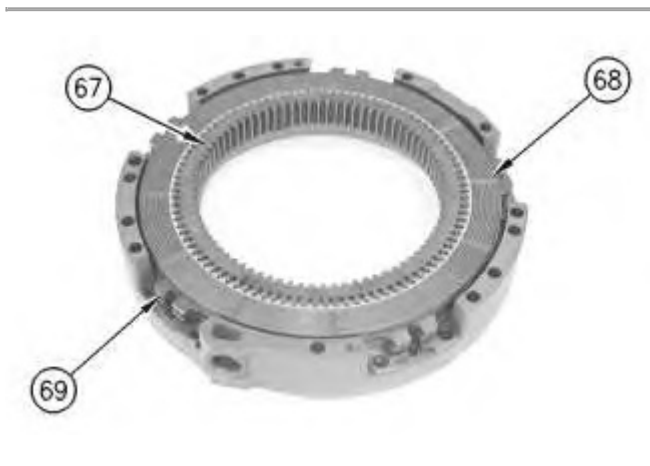

Illustration 33

g00318477

41. Remove ring gear (67), clutch discs (68) and plates (69) from the No. 2 clutch housing. Remove the piston from the housing. Remove the seal rings from the housing and the piston.

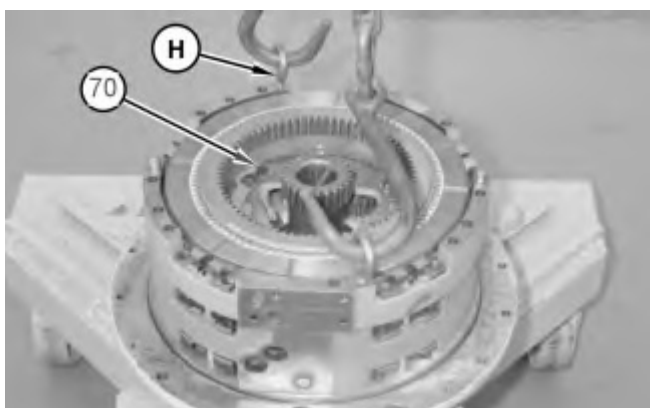

Illustration 34

g01305035



Illustration 35

g01305069

42. Remove bolts (70) and remove the locks and the plates that hold the No. 3 clutch housing in position.
43. Install Tooling (H) and a suitable lifting device to the No. 3 clutch housing. The weight of the No. 3 clutch housing is approximately 25 kg (55 lb). Remove the No. 3 clutch housing.
44. Remove five dowels (71) and ten springs (72) from the No. 4 and No. 5 clutch housings.



Illustration 36

g00318491

45. Remove ring gear (73), clutch discs (74), plate (75) and the piston from the clutch housing. Remove the seal rings from the piston and the clutch housing.

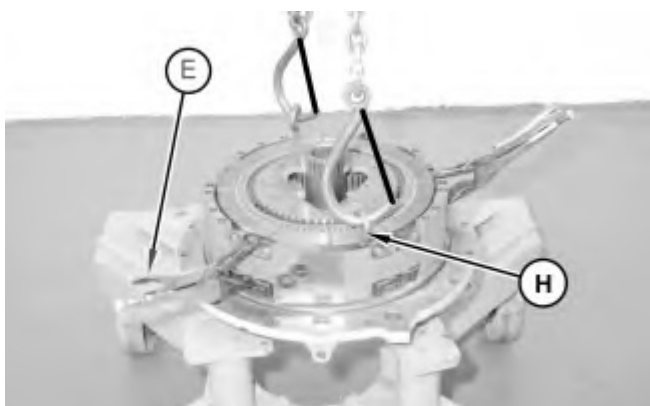

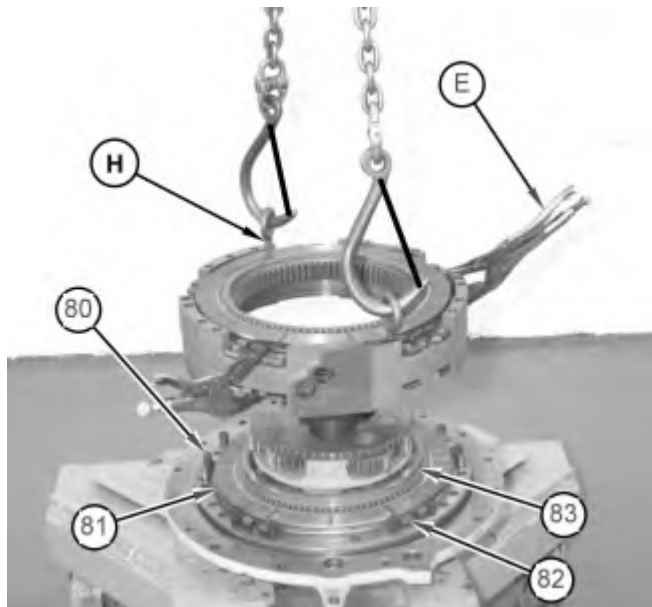

Illustration 38

46. Install Tooling (E) in order to keep the No. 4 and No. 5 clutch pistons in the clutch housing.
47. Install Tooling (H) and a suitable lifting device to No. 4 and No. 5 clutch housings. The weight of the No. 4 and No. 5 clutch housings is 29 kg (65 lb). Remove the clutch housing and the piston as a unit.
48. Remove springs (80), clutch discs (81), ring gear (83) and plate (82).

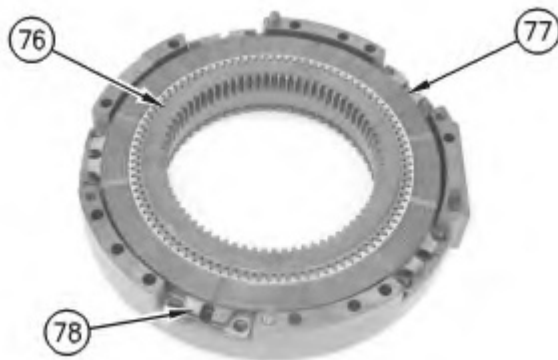

Illustration 39

49. Remove ring gear (76), clutch discs (77), and plate (78) from the clutch housing.
50. Turn the clutch housing upside-down. Remove Tooling (E). Remove the piston. Remove the ring seals from the piston and the housing.

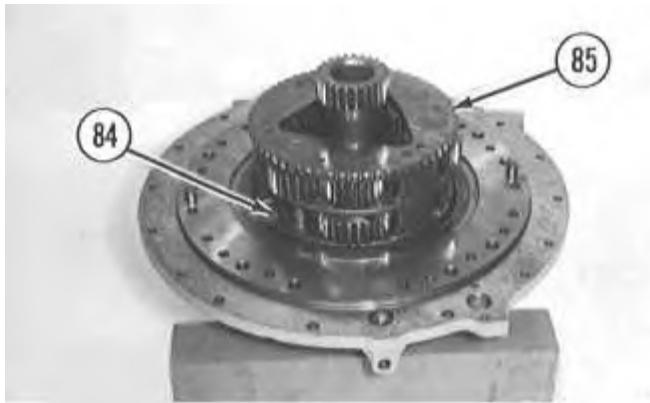

Illustration 40

g00318689

51. Remove bolts (84) and the locks that hold No. 2 carrier (85) to the transfer gear case.

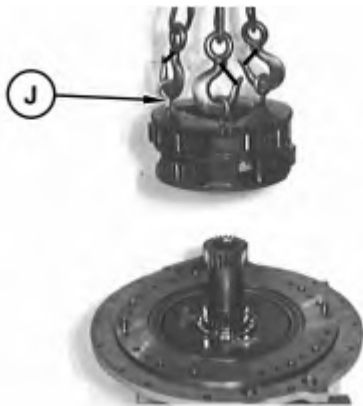
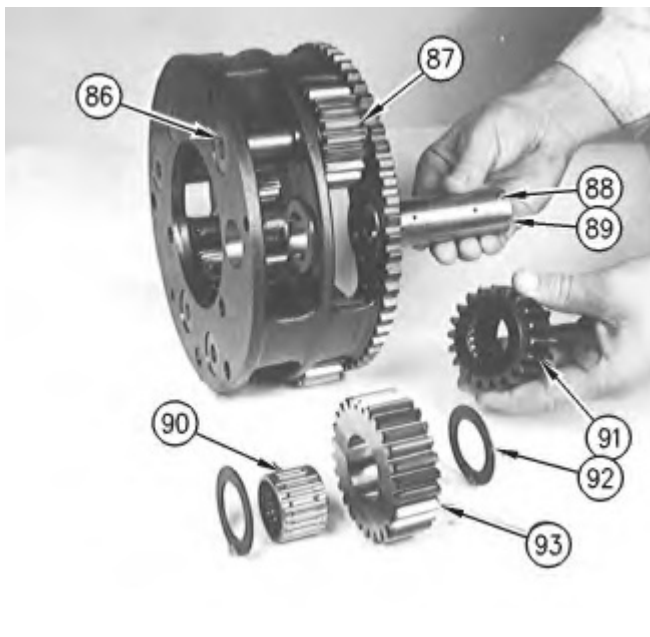

Illustration 41

g01305098

52. Install Tooling (J) and a suitable lifting device to the No. 2 carrier. The weight of the No. 2 carrier is approximately 23 kg (50 lb). Remove the No. 2 carrier.



Note: There is washer (92) on the top and the bottom of gear (93).

53. Put the No. 2 carrier on the side. Pull shafts (89) out of the carrier. Remove gear (93) and washers (92). Remove needle bearings (90) from gear (91).

Note: Use caution to prevent loss of balls (88) when shafts (89) are removed.

54. Remove shafts (89), gear (91) and the washers. Remove the needle bearings from gear (91).

Note: Use caution to prevent the loss of the balls when shafts (86) are removed.

55. Remove shafts (86), gear (87) and the washers. Remove the needle bearings from the gear.

Note: There is a washer on the top and the bottom of the gear.

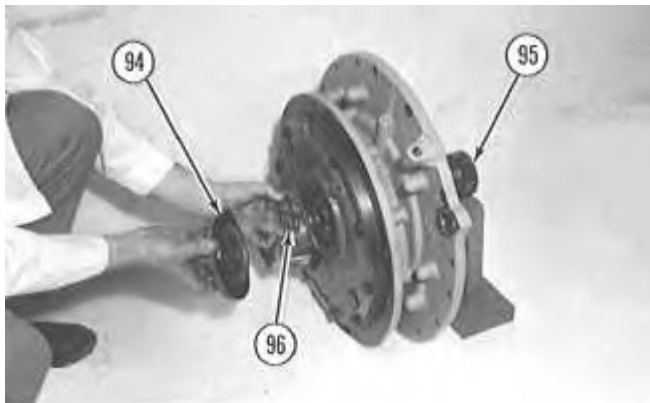

Illustration 43

g00318697

56. Remove cage (94), retainer ring (96) and output shaft (95).

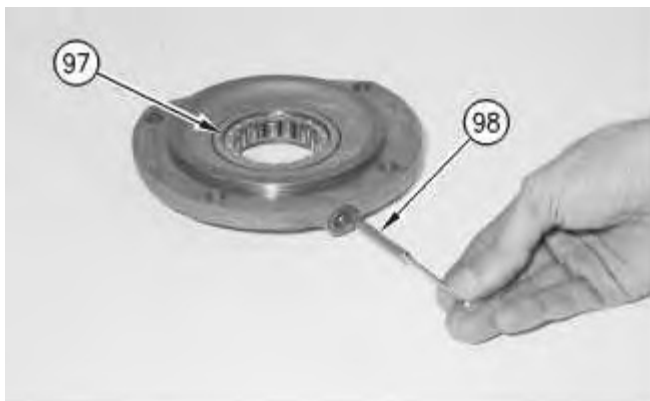

Illustration 44

g00318698

57. Remove dowel (98) from the cage. Use a Tooling (M) in order to remove dowel (98). Remove bearing (97).

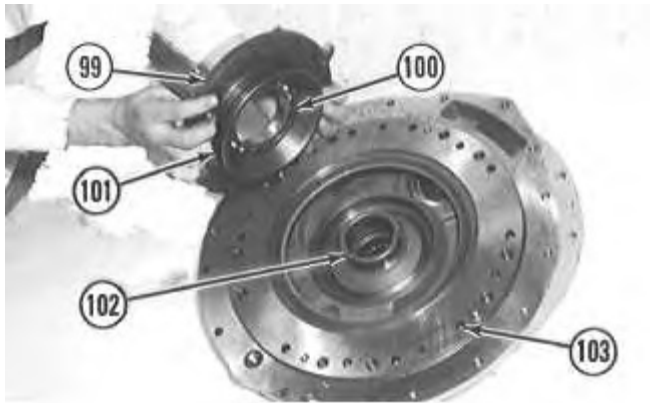

Illustration 45

g00318699

Note: Use caution in order to prevent the loss of ball (102) when the cage is removed.

58. Remove cage (99) with Tooling (K). Remove bearing (100).
59. Inspect piston ring seals (101). If the seals are damaged or worn remove the seals and install new seals.
60. Remove plate assembly (103).

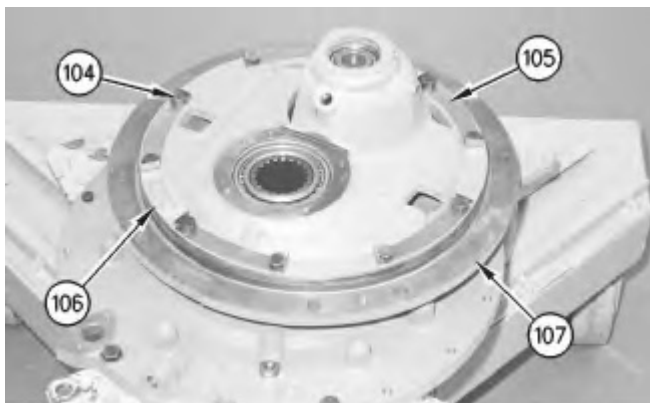

Illustration 46

g00318494

61. Remove bolts (104) and locks (105) that hold case assembly (106) to transfer gear case (107).
62. Remove the dowels that hold the case assembly in position on the transfer gear case. Use Tooling (L) in order to separate case assembly (106). Remove case assembly (106).

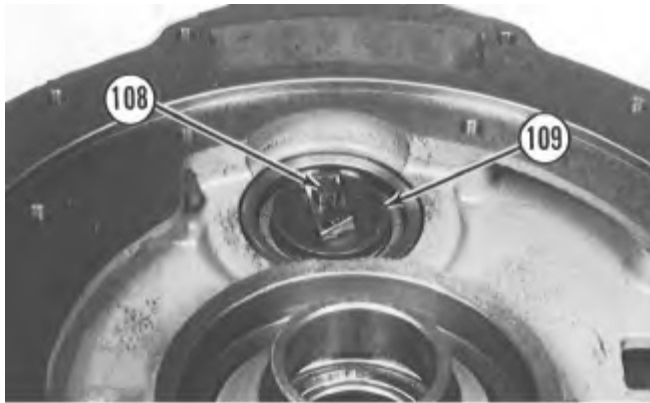

Illustration 47

g00318700

63. Remove bolts (108) and the lock. Remove retainer (109).
64. Remove the pinion from the transfer gear case.

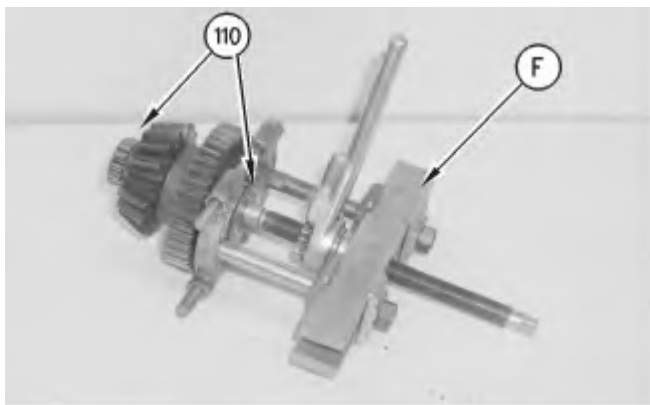

Illustration 48

g00318497

65. Remove bearings (110) and the spacer with Tooling (F).
66. Remove the transfer gear from the transfer gear case.

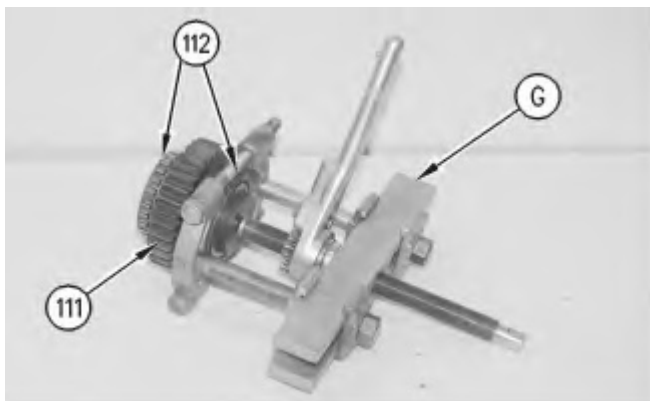

Illustration 49

g00318499

67. Use Tooling (G) and remove bearings (112) from transfer gear (111).

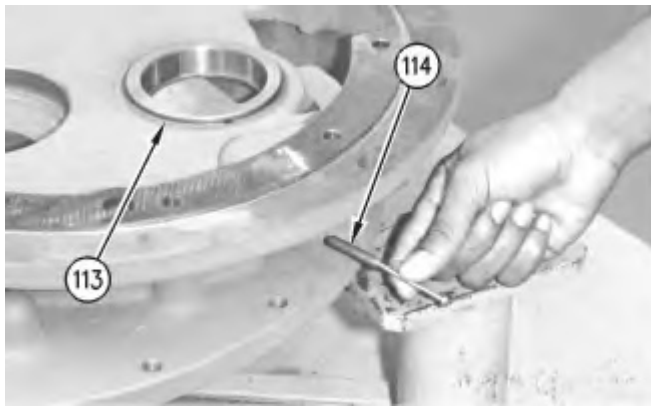

Illustration 50

g00318501

68. Remove the plugs and dowels (114). Use Tooling (M) in order to remove the dowels.
69. Remove races (113).

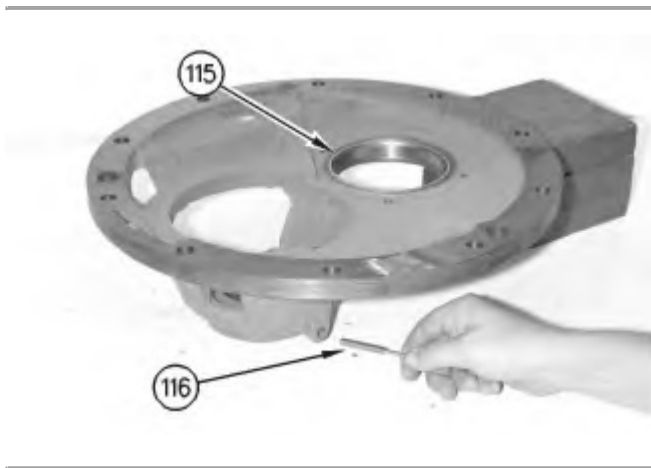

Illustration 51

g00318563

70. Remove the plugs and dowels (116). Use a Tooling (M) in order to remove the dowels.
 71. Remove races (115).
-

Product: TRACK-TYPE TRACTOR

Model: D6G2 XL TRACK-TYPE TRACTOR C6G

Configuration: D6G2 XL TRACK-TYPE TRACTOR C6G01000-UP (MACHINE) POWERED BY 3306 Engine

Disassembly and Assembly D6G Series II Track-Type Tractor Power Train

Media Number -KENR6344-02

Publication Date -01/09/2018

Date Updated -14/09/2018

i02606943

Transmission and Transfer Gears - Assemble

SMCS - 3002-016; 3030-016; 3159-016

Assembly Procedure

Table 1

Required Toolings			
Tool	Part Number	Part Description	Qty
A	1P-2420	Repair Stand	1
E	FT-0833	Clamp	2
H	1P-7407	Eyebolt	3
J	1P-7405	Eyebolt	3
K	-	Forcing Screws 1/2 inch - 13 NC	3
L	-	Forcing Screws 1/2 inch - 13 NC	3
M	-	Screw 6 - 40	1
N	1P-0532	Handle	1
	1P-0516	Drive Plate	1
P	1P-0531	Handle	1
	1P-0493	Drive Plate	1
R	1P-0463	Drive Plate	1
	1P-0529	Handle	1

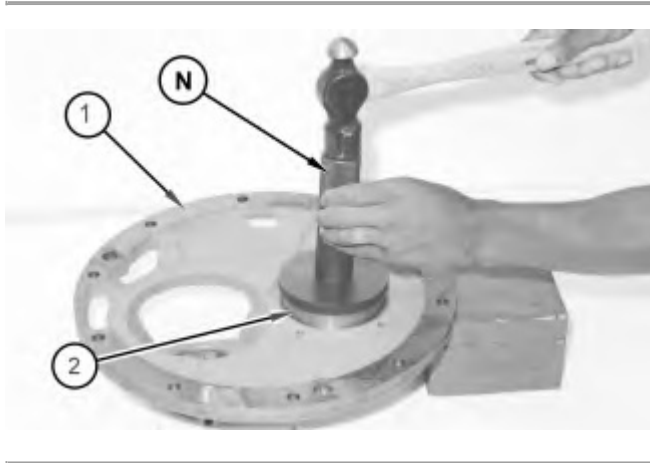

Illustration 1

g01305241

1. Lower the temperature of race (2). Install race (2) by using Tooling (N). Make sure that the hole in the race is in alignment with the hole in the case. Install the dowel and the plug that holds the race in position in the case.

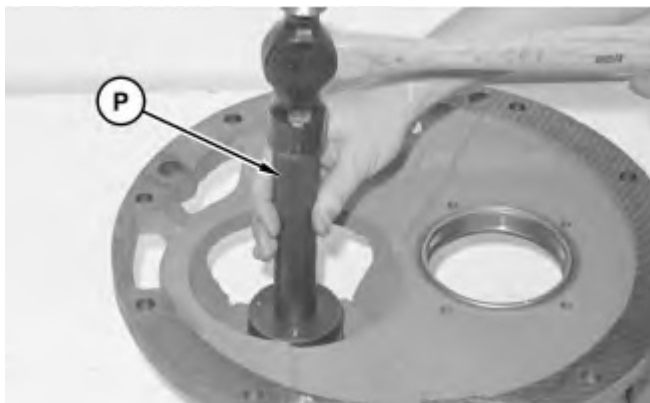
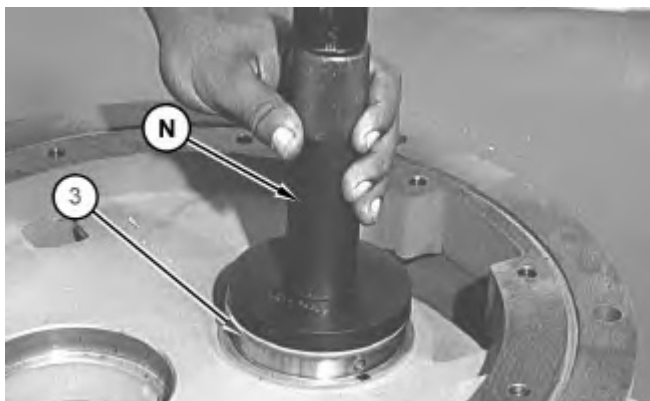

Illustration 2

g01305244

2. Lower the temperature of the bearing race. Install the bearing in the case by using Tooling (P). Make sure that the hole in the bearing is in alignment with the hole in the case. Install the dowel and the plug that holds the bearing race in the case.



3. Lower the temperature of bearing race (3). Install the bearing race by using Tooling (N). Make sure that the hole in the race is in alignment with the hole in the case. Install the dowel and the plug that holds the race in position in the case.

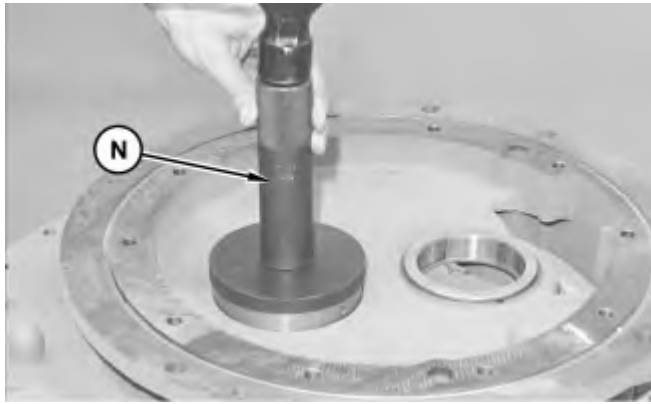

Illustration 4

4. Lower the temperature of the bearing race. Install the race by using Tooling (N). Make sure that the hole in the race is in alignment with the hole in the case. Install the dowel and the plug that holds the race in position in the case.

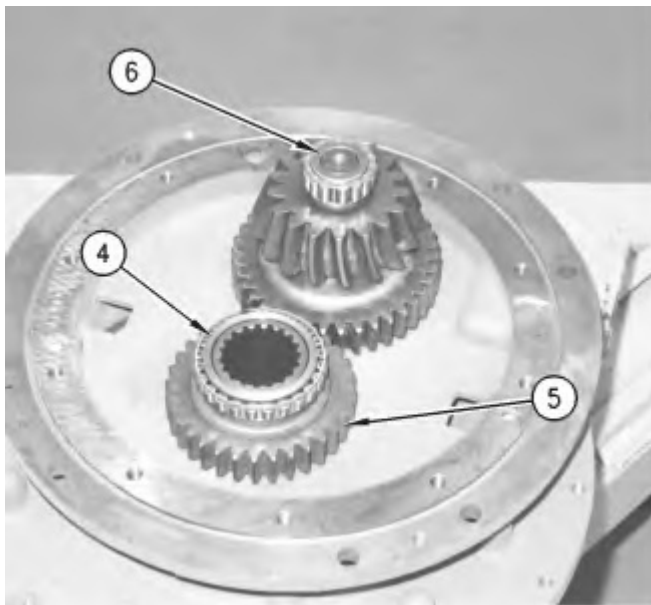

Illustration 5

5. Raise the temperature of bearings (4). Install bearing (4) on each end of transfer gear (5). Make sure that the bearings are in contact with the shoulders on the gear.
6. Install the transfer gear in the case.
7. Raise the temperature of bearing (6). Install bearing (6) on the pinion gear. Make sure that the bearing makes contact with the shoulder on the gear. Turn the gear upside-down. Install

Thank you so much for reading.
Please click the “Buy Now!”
button below to download the
complete manual.



After you pay.

You can download the most
perfect and complete manual in
the world immediately.

Our support email:

ebooklibonline@outlook.com