

Model: TH330B TELEHANDLER SLB

Configuration: TH330B Telehandler SLB00001-UP (MACHINE) POWERED BY 3054 Engine

Disassembly and Assembly TH220B and TH330B Telehandlers Power Train

Media Number -REN7706-01

Publication Date -01/08/2006

Date Updated -21/08/2006

i02211551

Transmission - Disassemble

SMCS - 3030-015

Disassembly Procedure

Table 1

Required Tools			
Tool	Part Number	Part Description	Qty
A	138-7575	Link Bracket	2
B	1U-7262	Telescoping Magnet	1
C	1P-2320	Combination Puller	1
D	1P-1857	Retaining Ring Pliers	1
E	156-7100	Slide Hammer Puller Gp	1
F	1P-0510	Driver Gp	1
G	1P-1856	Retaining Ring Pliers	1
H	1P-2321	Combination Puller	1
J	4C-8359	Eyebolt (M12)	1
K	1P-1860	Retaining Ring Pliers	1
L	8B-7550	Push-Puller Leg	1
	8H-0663	Bearing Puller Gp	1
M	1P-0074	Slide Hammer Puller Gp	1
N	-	Forcing Screw M4	1

Start By:

- A. Remove the transmission and the torque converter. Refer to Disassembly and Assembly, "Transmission and Torque Converter - Remove".

NOTICE

Care must be taken to ensure that fluids are contained during performance of inspection, maintenance, testing, adjusting and repair of the product. Be prepared to collect the fluid with suitable containers before opening any compartment or disassembling any component containing fluids.

Refer to Special Publication, NENG2500, "Caterpillar Tools and Shop Products Guide" for tools and supplies suitable to collect and contain fluids on Caterpillar products.

Dispose of all fluids according to local regulations and mandates.

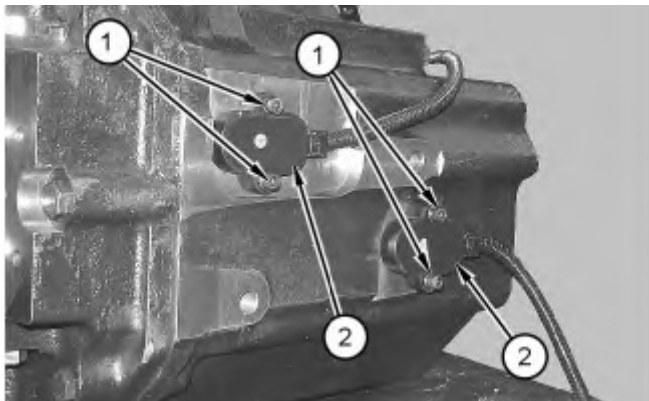

Illustration 1

g01116800

1. Remove screws (1) in order to remove sensors (2) .
 2. Machines that are equipped with five speeds have additional components that need to be removed.
-

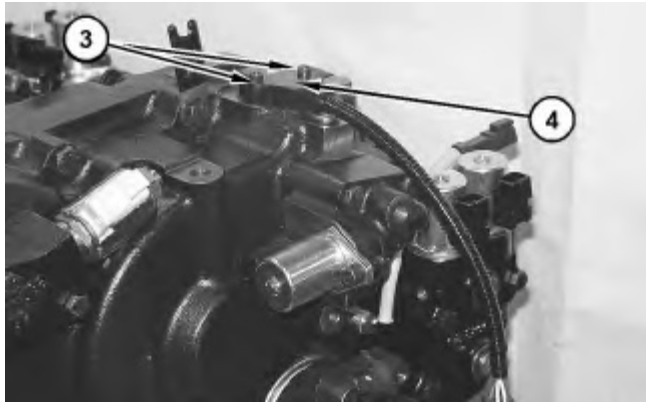

Illustration 2

g01033803

Transmission Position Sensor and Actuator on the Fifth Speed

- a. Remove screws (3) in order to remove sensor (4) .



Illustration 3

g00895262



Personal injury can result from being struck by parts propelled by a released spring force.

Make sure to wear all necessary protective equipment.

Follow the recommended procedure and use all recommended tooling to release the spring force.

- b. Remove cap (5) .

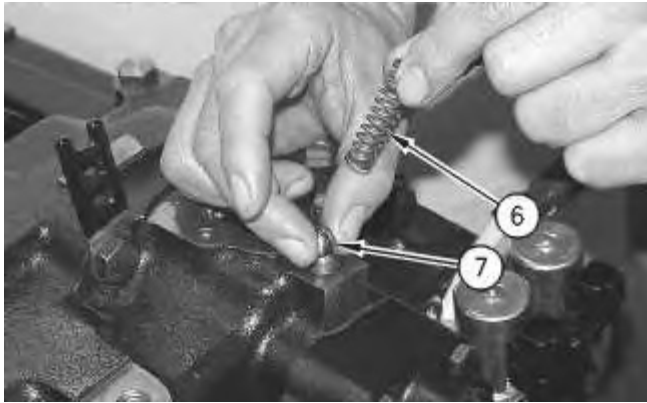

Illustration 4

g00895720

- c. Remove spring (6). Use Tooling (B) in order to remove detent ball (7) .

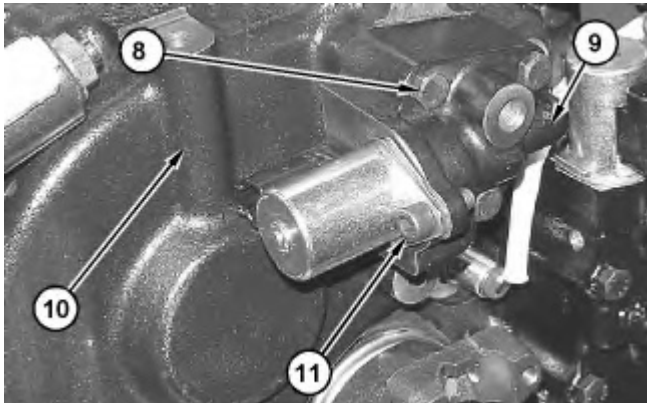

Illustration 5

g01033827

- d. Remove bolts (8). Remove actuator (9) and the O-ring seals from transmission cover (10). Remove screw (11) .

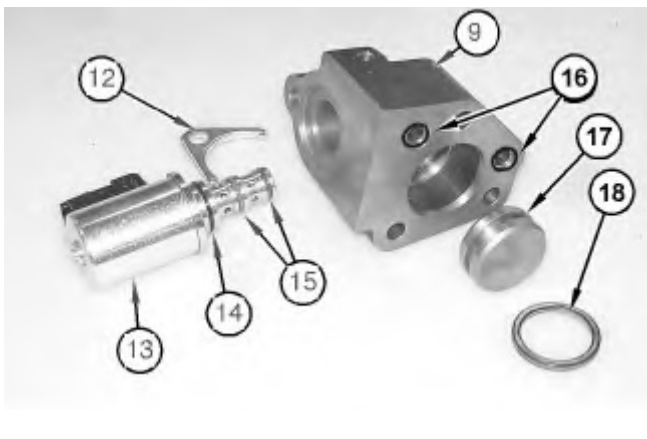

Illustration 6

g01033830

- e. Remove locking plate (12) in order to remove solenoid (13) from actuator (9). Remove O-ring seals (14) and (15) .
- f. Remove actuator piston (17) from actuator (9). Remove O-ring seals (16) and (18) .

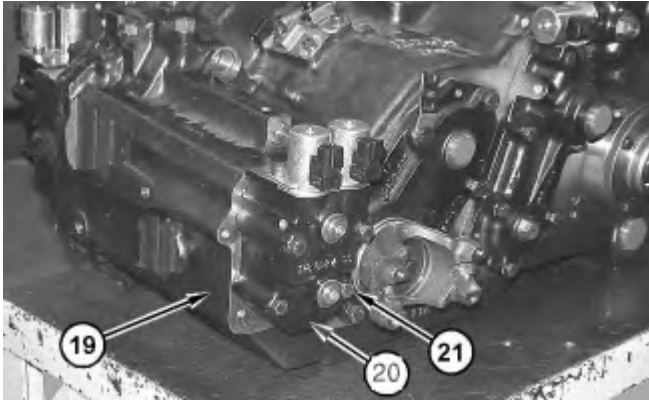

Illustration 7

g01033886

3. Remove bolts (21). Remove actuator (20) and the O-ring seals from transmission housing (19) .

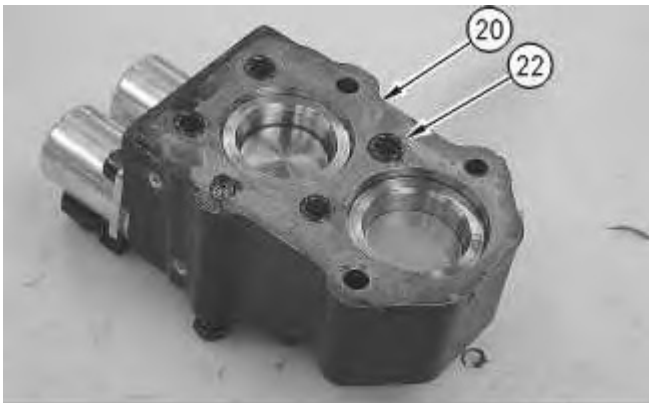

Illustration 8

g00892853

4. Remove O-ring seals (22) from actuator (20) .
-

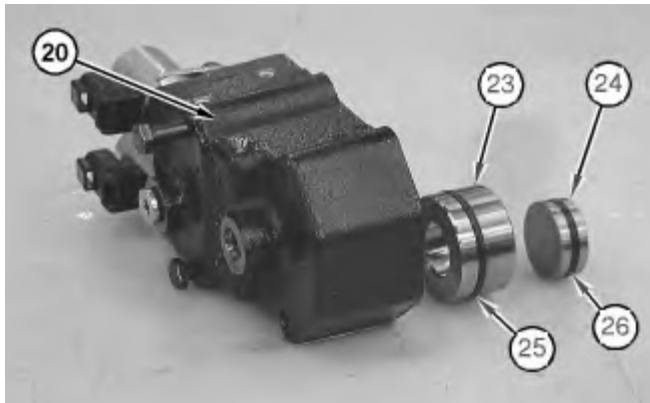

Illustration 9

g01033887

5. Remove neutralizing piston (23) and actuator piston (24) from actuator (20). Remove O-ring seals (25) and (26) .

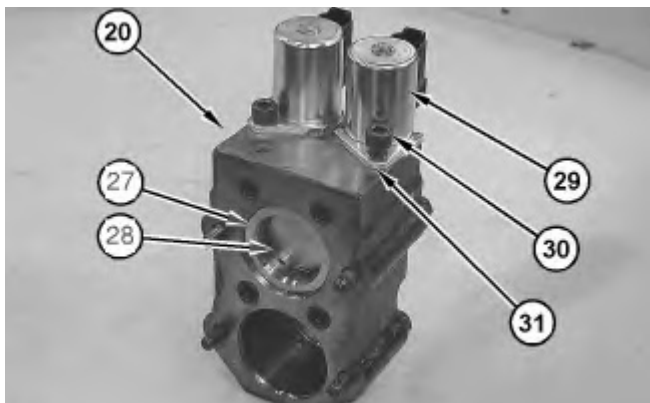
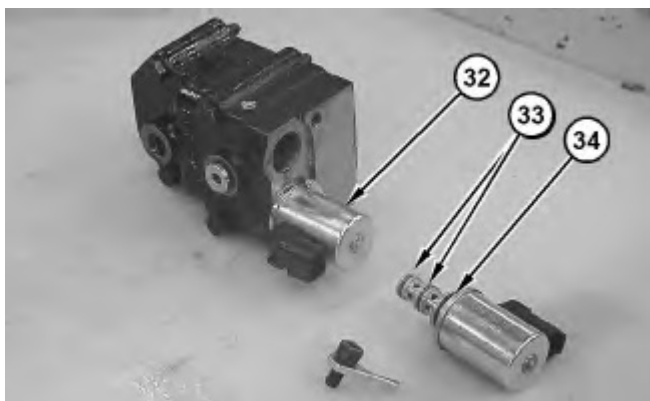

Illustration 10

g01033891

6. Repeat Step 5 for neutralizing piston (27) and actuator piston (28) .
7. Remove screw (30) and locking plate (31) in order to remove solenoids (29) from actuator (20) .



8. Remove O-ring seals (33) and (34) .
9. Repeat Step 7 and Step 8 for solenoid (32) .

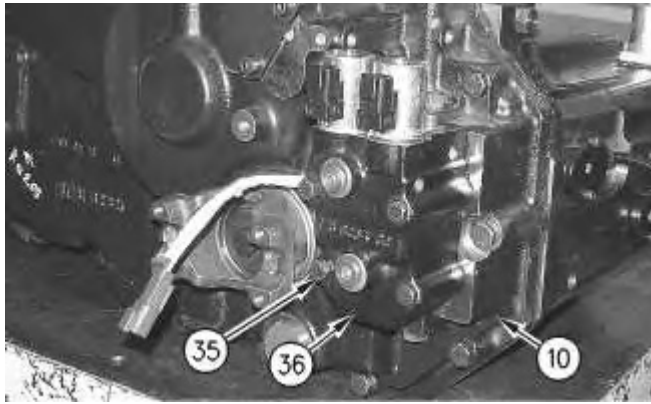

Illustration 12

10. Remove bolts (35). Remove actuator (36) and the O-ring seals from transmission cover (10) .
11. Repeat Step 4 to Step 9 for actuator (36) .

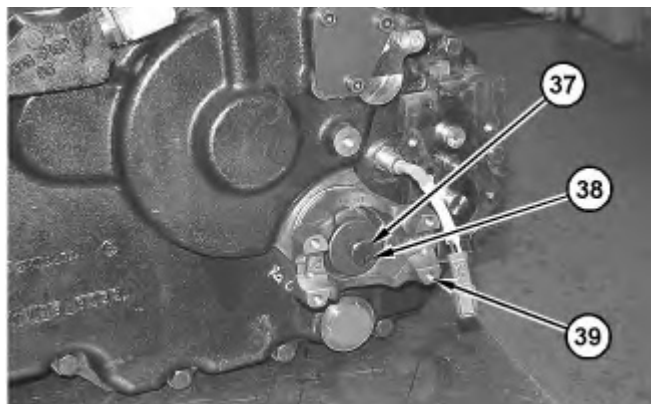

Illustration 13

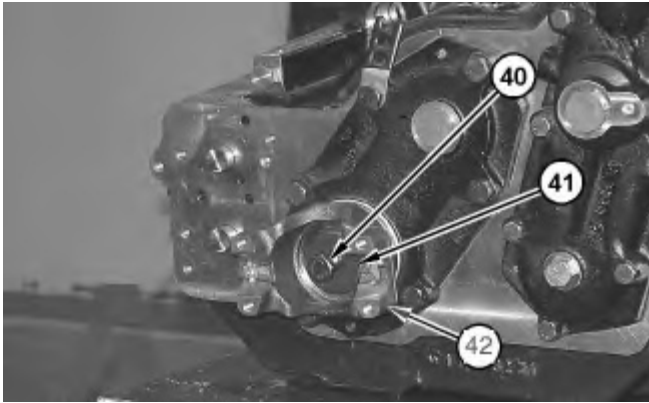

Illustration 14

g01033901

12. Remove bolts (37) and (40) and washers (38) and (41). Remove drive yokes (39) and (42) from both ends of the output shaft.

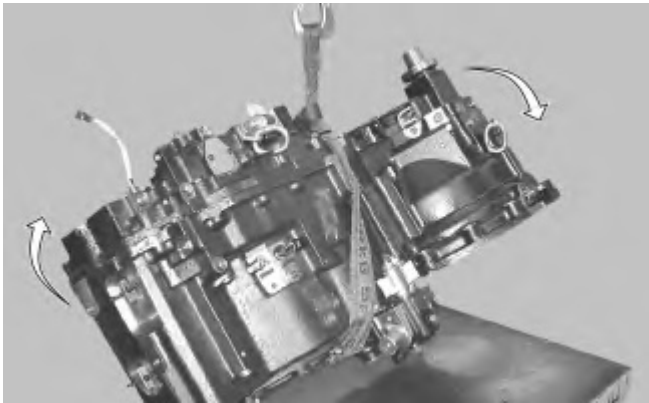

Illustration 15

g01116695



Illustration 16

g00893167

13. Attach a suitable lifting device to the transmission and position the transmission onto suitable blocking. The weight of the transmission is approximately 230 kg (507 lb).

Note: Ensure that the suitable blocking allows clearance between valve housing (43) and the bench.

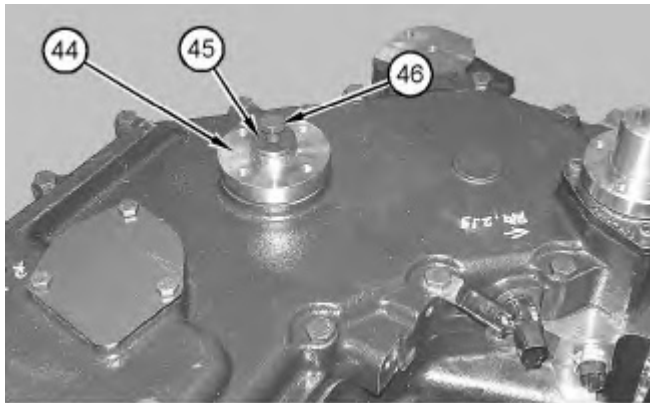

Illustration 17

g01033905

14. Remove bolt (46) and washer (45) in order to remove fan drive (44) and the O-ring seal.

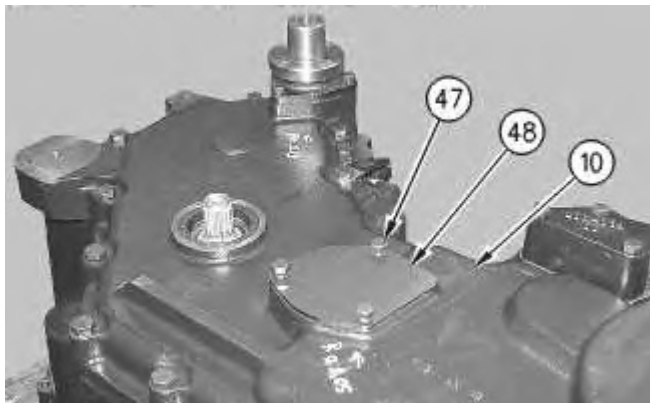

Illustration 18

g00893171

15. Remove bolts (47) in order to remove access panel (48) from transmission cover (10) .
-

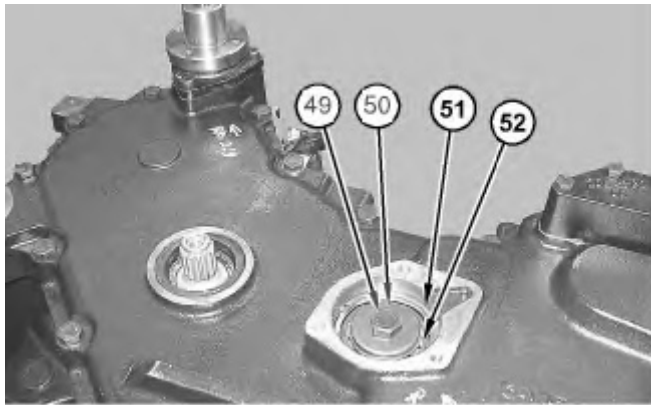

Illustration 19

g01033909

16. Remove bolt (49) and washer (50). Remove ring (52) from roller bearing (51) .

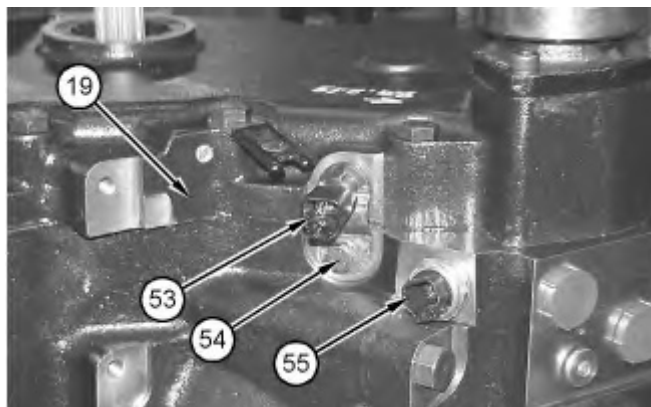

Illustration 20

g01042331

17. Remove temperature sensor (55) from transmission housing (19) .
18. Remove bolt (54) in order to remove speed sensor (53) .

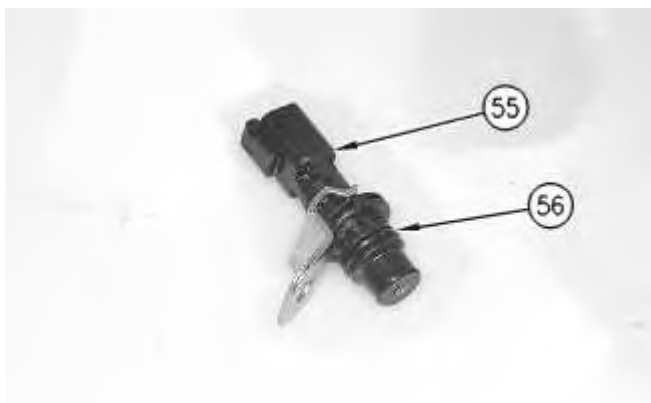

Illustration 21

g00896588

19. Remove O-ring seal (56) from speed sensor (55) .

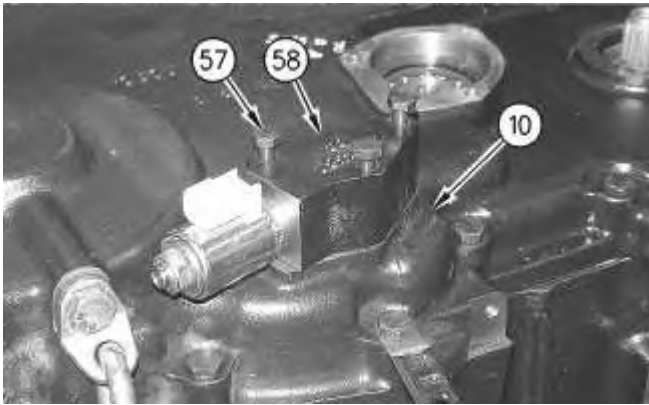

Illustration 22

g00893174

20. Remove bolts (57). Remove modulating valve (58) and the O-ring seals from transmission cover (10) .

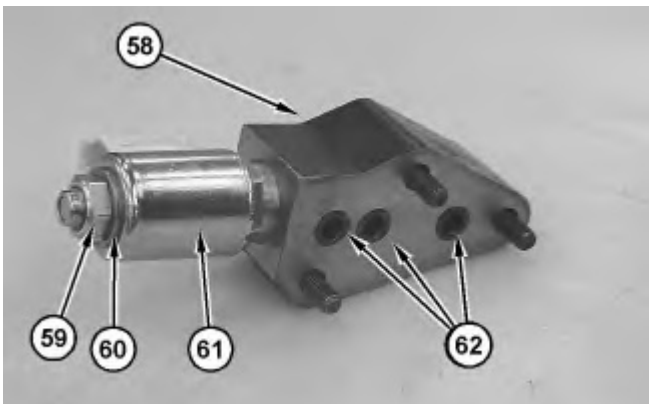

Illustration 23

g01033922

21. Remove O-ring seals (62) from modulating valve (58). Remove nut (59) and washer (60) in order to remove solenoid (61) .
-

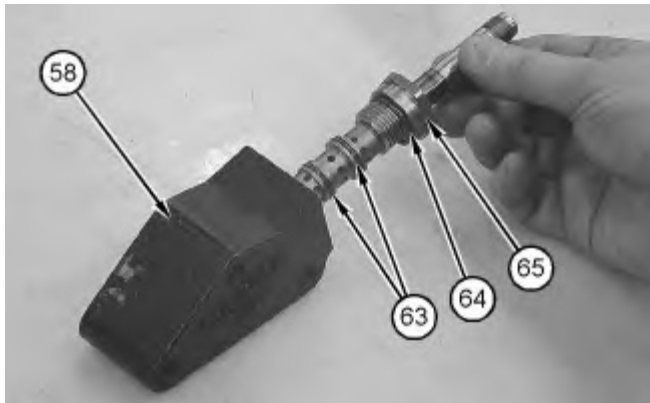

Illustration 24

g01035103

22. Remove valve spool (65) from modulating valve (58). Remove O-ring seals (63) and (64) .

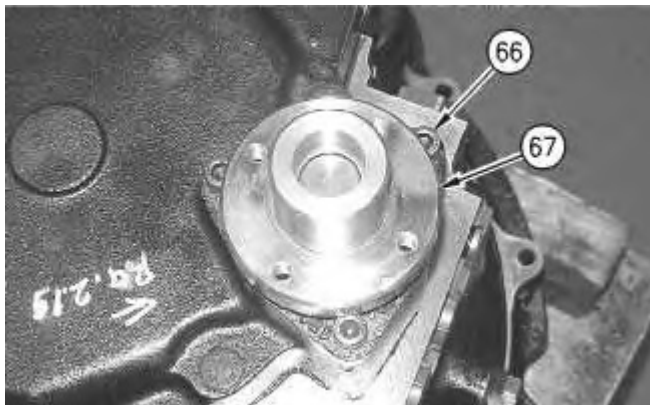

Illustration 25

g00893230

23. Remove screws (66) in order to remove idler (67) .



Illustration 26

g00893246



Illustration 27

g00893259

24. Use a suitable press in order to take the load off retaining ring (68). Remove retaining ring (68) that secures bearing (69) .



Illustration 28

g00893302

25. Use a suitable press in order to remove bearing (69) from mounting flange (70) .

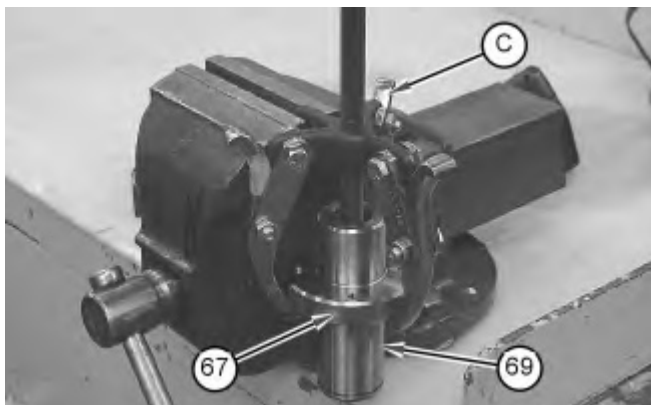

Illustration 29

g01116697

26. Use Tooling (C) and a suitable vise in order to remove bearing (69) from idler (67) .

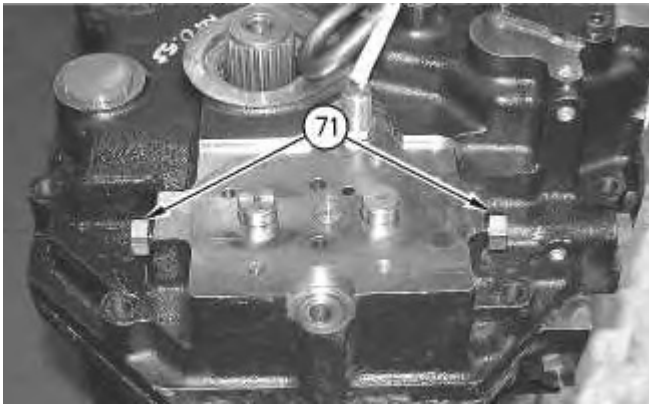

Illustration 30

g00893374

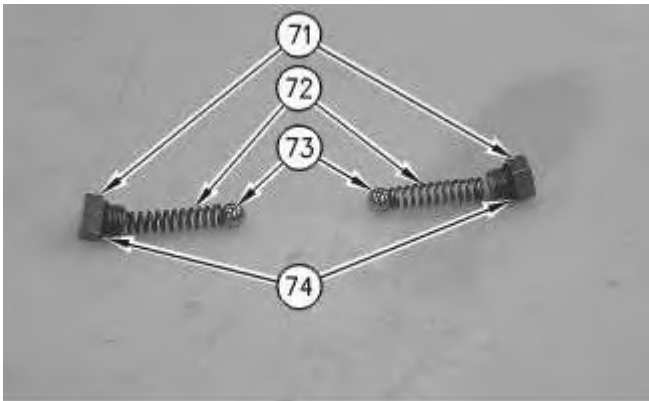

Illustration 31

g00893387

 **WARNING**

Personal injury can result from being struck by parts propelled by a released spring force.

Make sure to wear all necessary protective equipment.

Follow the recommended procedure and use all recommended tooling to release the spring force.

27. Remove spring retainers (71), springs (72), and detent balls (73). Use Tooling (B) in order to remove the two detent balls from the transmission housing. Remove O-ring seals (74) from spring retainers (71) .

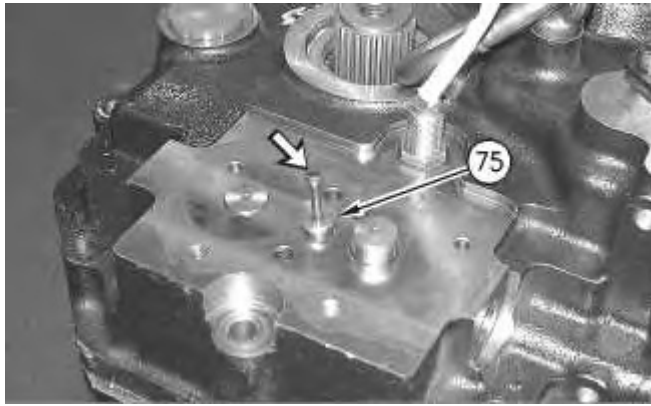

Illustration 32

g00893598

28. Use Tooling (N) in order to remove cap (75) .

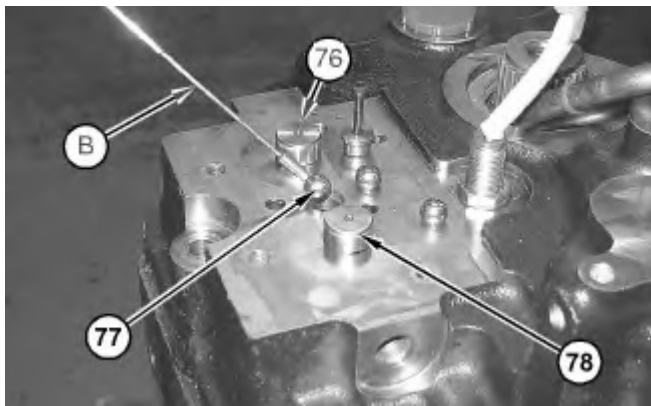

Illustration 33

g01033936

Typical example of Tooling (B)

29. Make sure that shift rail (76) and shift rail (78) are in the NEUTRAL position. Use Tooling (B) in order to remove detent balls (77) .
-

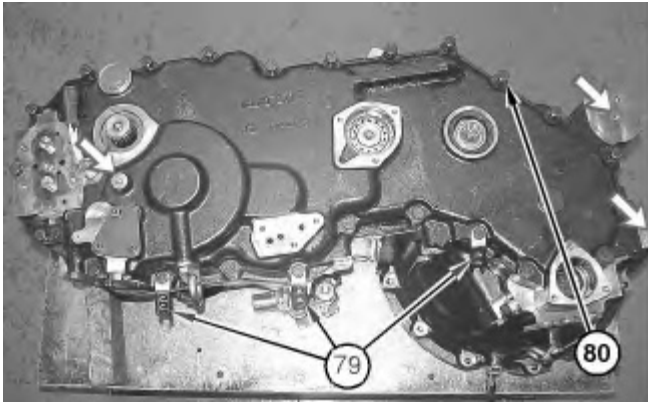

Illustration 34

g01033941

Note: Record the positions of clips (79) before removing bolts (80) .

30. Remove bolts (80) .
31. Attach Tooling (A) to the holes that are shown in illustration 34.

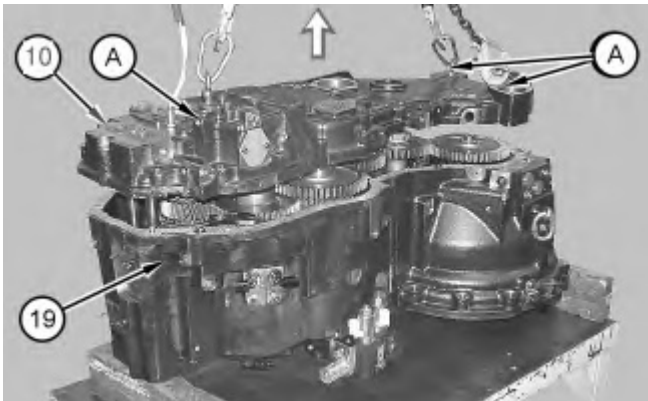

Illustration 35

g01117373

32. Use Tooling (A) and a suitable lifting device in order to lift transmission cover (10). The weight of transmission cover (10) is approximately 42 kg (93 lb). Lift transmission cover (10) away from transmission housing (19) .

Note: Ensure that the transmission cover is lifted squarely in order to smoothly disengage the two locating pins that are between the interface of transmission cover (10) and transmission housing (19) .

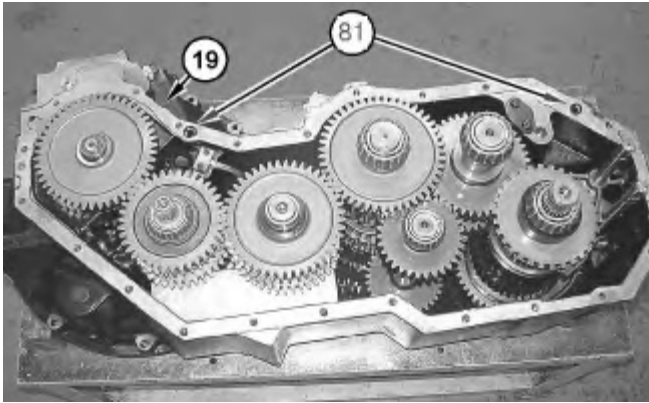

Illustration 36

g01043951

33. Remove O-ring seals (81) from transmission housing (19) .

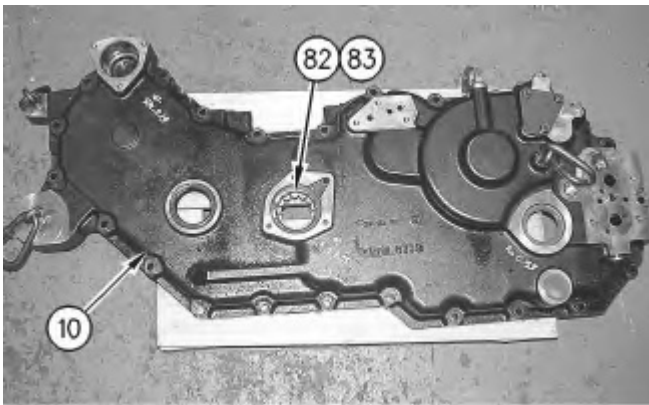

Illustration 37

g00895558

34. Use Tooling (D) in order to remove retaining ring (82). Remove bearing (83) from transmission cover (10) .



Illustration 38

g01116701

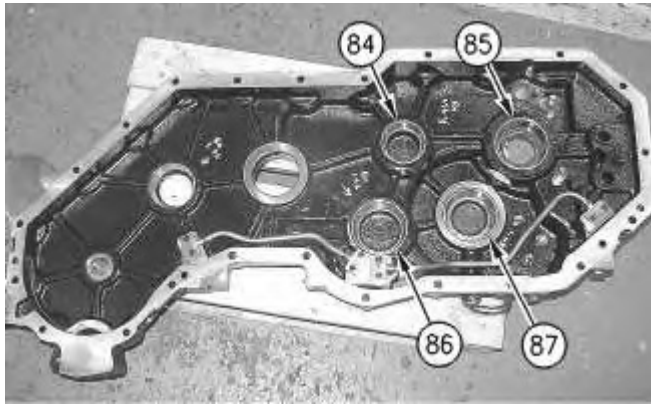

Illustration 39

g00895560

35. Use Tooling (E) in order to remove bearing cups (84), (85), (86), and (87). Remove any shims that are under bearing cups (84), (85), (86), and (87) .

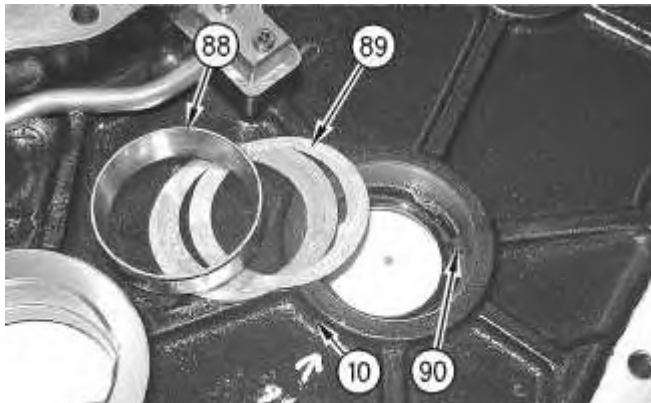

Illustration 40

g00895562

36. Use Tooling (E) in order to remove bearing cup (88) from transmission cover (10). Remove shims (89). Use Tooling (D) in order to remove retaining ring (90) .



Illustration 41

g01116702

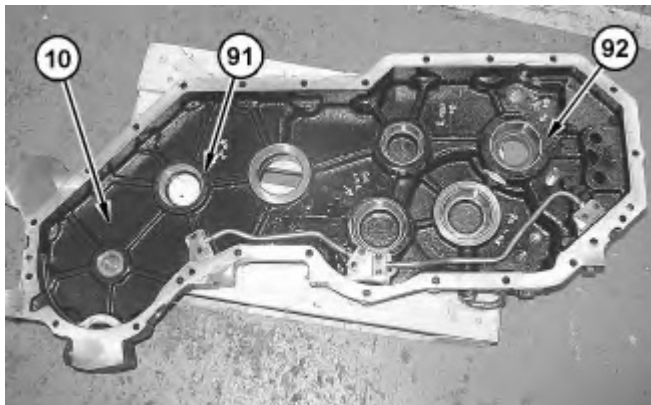

Illustration 42

g01035172

37. Use Tooling (F) in order to remove seals (91) and (92) from transmission cover (10).

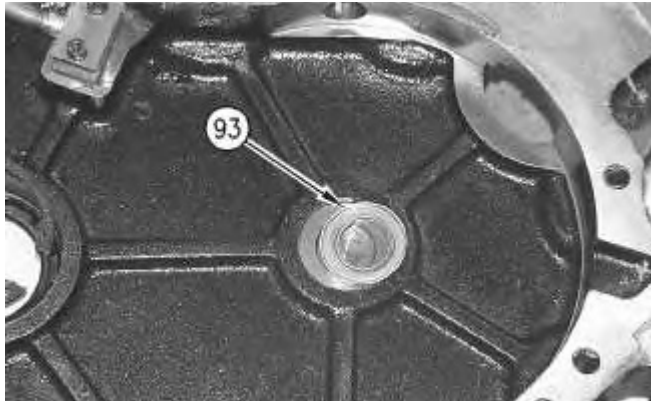
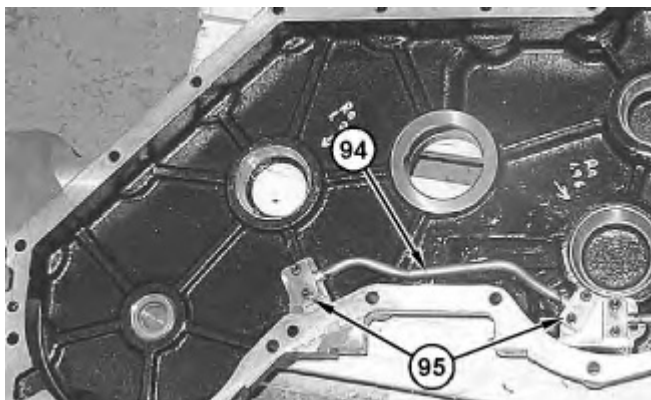

Illustration 43

g00895566

38. Remove bearing carrier (93) .



39. Remove screws (95). Remove tube assembly (94) and the O-ring seals.

Note: The position of the oil tube in a transmission with five speeds is different to the position of the oil tube for a transmission with four speeds.

40. Repeat Step 39 for the other tube assembly.

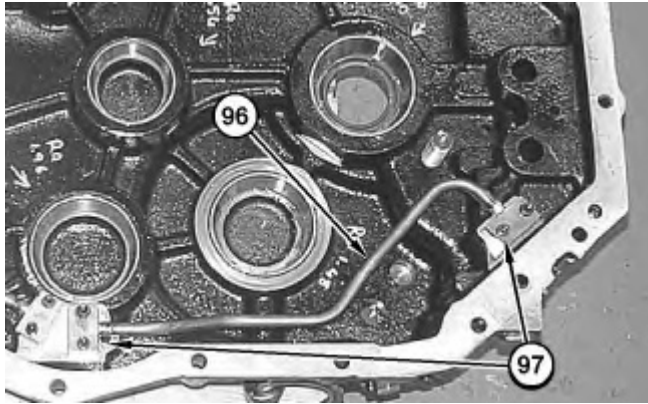

Illustration 45

g01033960

Cover of a transmission with four speeds

- a. Remove screws (97) in order to remove tube assembly (96) .



Illustration 46

g01033964

Cover of a transmission with five speeds

- b. Remove screws (99). Remove tube assembly (98) and the O-ring seals.

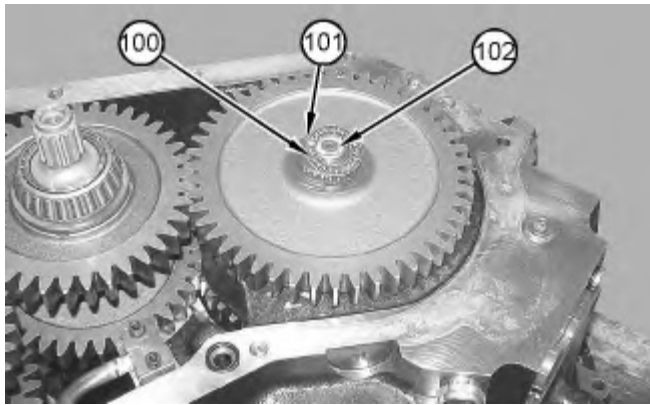

Illustration 47

g01042376

41. Remove thrust bearing (100) and sleeve (101) from input shaft (102) .

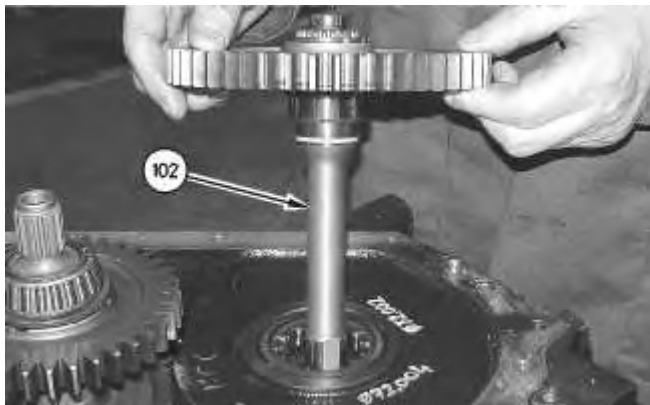

Illustration 48

g00893604

42. Remove input shaft (102) .

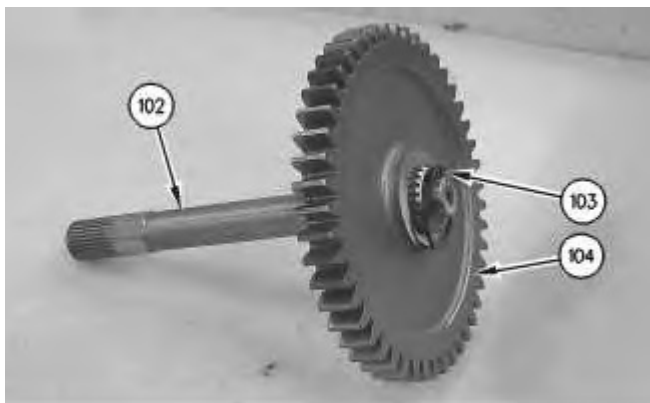

Illustration 49

g00893605

43. Use Tooling (K) in order to remove retaining ring (103). Remove gear (104) from input shaft (102) .

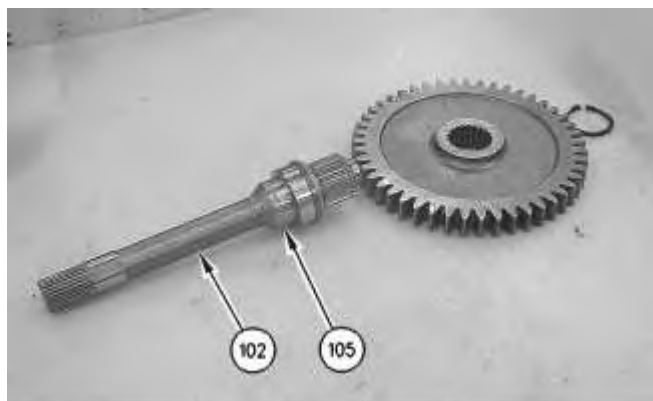

Illustration 50

g00893606

44. Remove ring seal (105) from input shaft (102) .

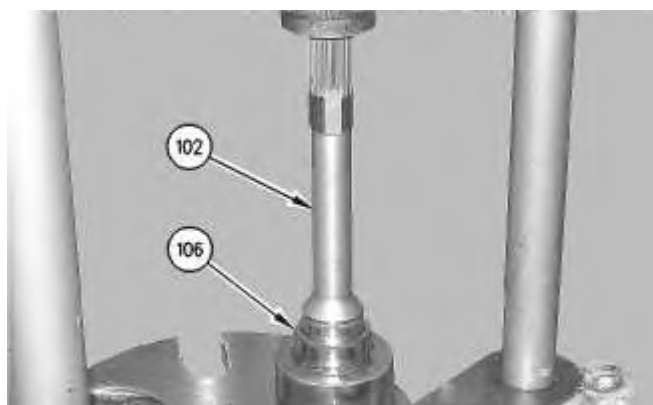

Illustration 51

g00893607

45. Use a suitable press in order to remove bearing race (106) from input shaft (102) .
-

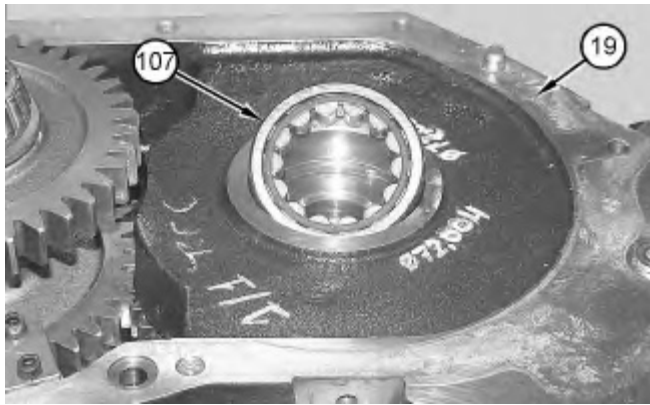

Illustration 52

g01042432

46. Remove roller bearing (107) from transmission housing (19) .



Illustration 53

g00893609

47. Remove fan drive shaft (108) .



Illustration 54

g01042449

48. Remove bearing cup (109) from transmission housing (19) .

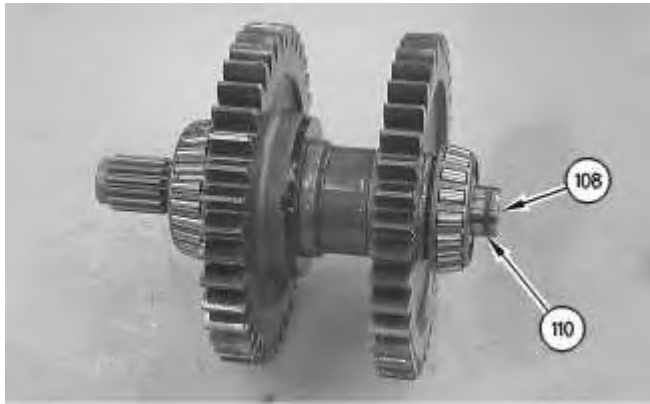

Illustration 55

g00893610

49. Remove ring seal (110) from fan drive shaft (108) .

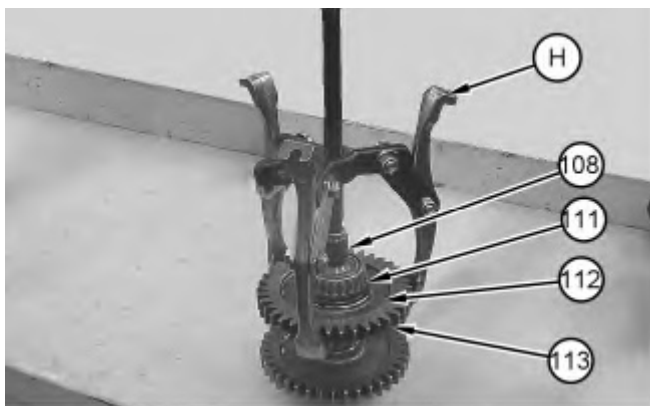

Illustration 56

g01116704

50. Use Tooling (H) in order to remove idler gear (113), thrust washer (112), and bearing cone (111) from fan drive shaft (108) .

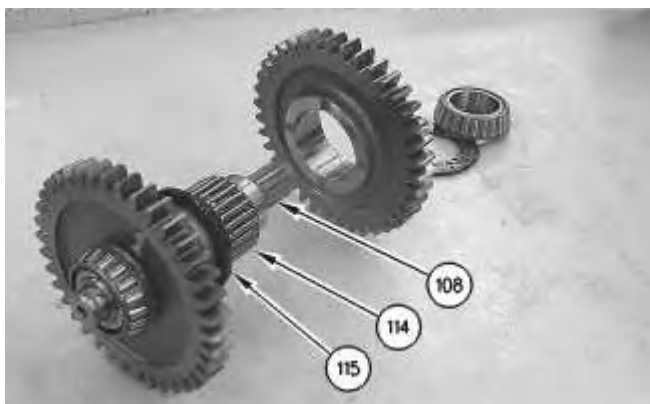

Illustration 57

g01116704

51. Remove needle bearing (114) and thrust washer (115) from fan drive shaft (108) .

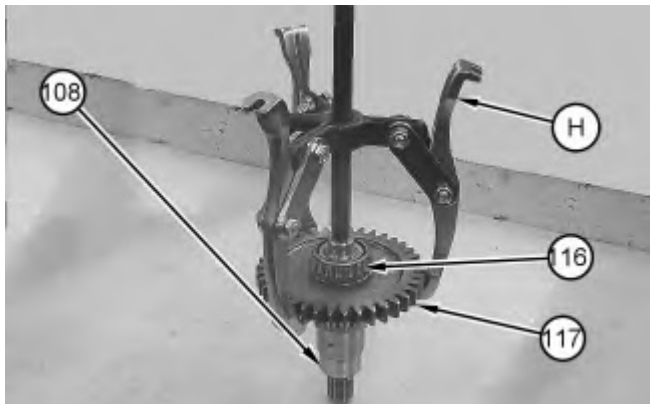

Illustration 58

52. Use Tooling (H) in order to remove drive gear (117) and bearing cone (116) from the other end of fan drive shaft (108) .

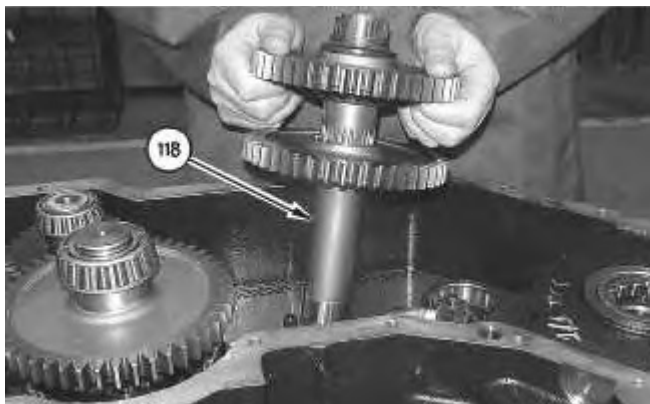

Illustration 59

53. Remove pump drive shaft (118) .
-

Thank you so much for reading.
Please click the “Buy Now!”
button below to download the
complete manual.



After you pay.

You can download the most
perfect and complete manual in
the world immediately.

Our support email:

ebooklibonline@outlook.com