

Product: TELEHANDLER

Model: TH350B TELEHANDLER SLD

Configuration: TH350B Telehandler SLD00001-01640 (MACHINE) POWERED BY 3054E Engine

## Disassembly and Assembly 3054 Engine for Caterpillar Built Machines

Media Number -SEN6241-13

Publication Date -01/08/2008

Date Updated -04/08/2008

i02253357

# Gear Group (Front) - Remove

SMCS - 1206-011

## Removal Procedure

Table 1

Required Tools			
Tool	Part Number	Part Description	Qty
A	8S-2264	Puller Group	1
B	173-9774	Wrench Bit	1

### Start By:

- A. Remove the front cover. Refer to Disassembly and Assembly, "Front Cover - Remove".

---

### NOTICE

**Keep all parts clean from contaminants.**

**Contaminants may cause rapid wear and shortened component life.**

---

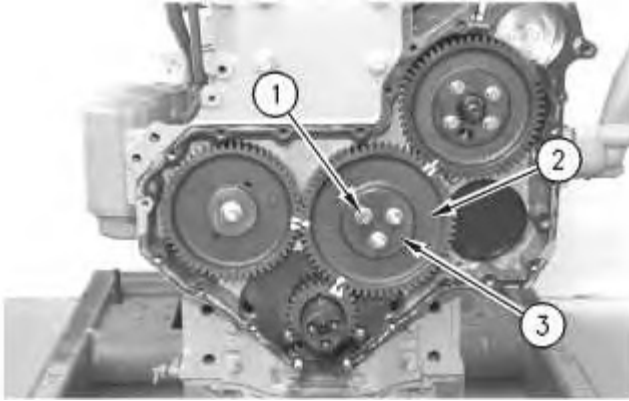

Illustration 1

g00556563

**Note:** It may be necessary to pin the fuel pump in order to maintain the correct timing. Refer to Disassembly and Assembly, "Fuel Injection Pump - Remove" for the correct procedure.

1. Align the timing marks on the crankshaft gear, the camshaft gear, and the idler gear, as shown.
2. Remove bolts (1) from idler gear (2) .
3. Remove idler gear (2) and retainer plate (3) .



Illustration 2

g00556757

4. Remove bushing (4) from idler gear (2) , if necessary.
5. Remove the bushing with a suitable puller. If the bushing cannot be removed with a puller, grind the face off of one bushing. The remainder of the bushing can then be removed with a press.

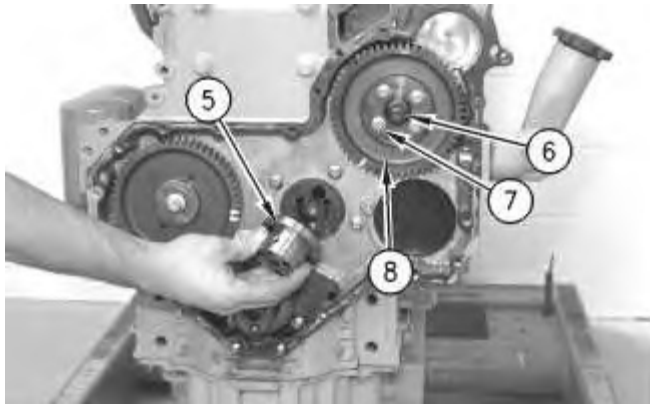

---

Illustration 3

g00556758

6. Remove idler gear hub (5) from the cylinder block.
7. Remove nut (6) and the spring washer from fuel injection pump gear (8) .
8. Remove bolts (7) from fuel injection pump gear (8) .

**Note:** Some fuel injection pump gears may have a tamper proof torx screw in place of one of the four bolts. Use Tooling (B) to remove the tamper proof torx screw, if necessary.

9. Use Tooling (A) to remove fuel injection pump gear (8) .
-

Product: TELEHANDLER

Model: TH350B TELEHANDLER SLD

Configuration: TH350B Telehandler SLD00001-01640 (MACHINE) POWERED BY 3054E Engine

## Disassembly and Assembly 3054 Engine for Caterpillar Built Machines

Media Number -SEN6241-13

Publication Date -01/08/2008

Date Updated -04/08/2008

i01744102

# Gear Group (Front) - Install

SMCS - 1206-012

## Installation Procedure

---

### NOTICE

**Keep all parts clean from contaminants.**

**Contaminants may cause rapid wear and shortened component life.**

---

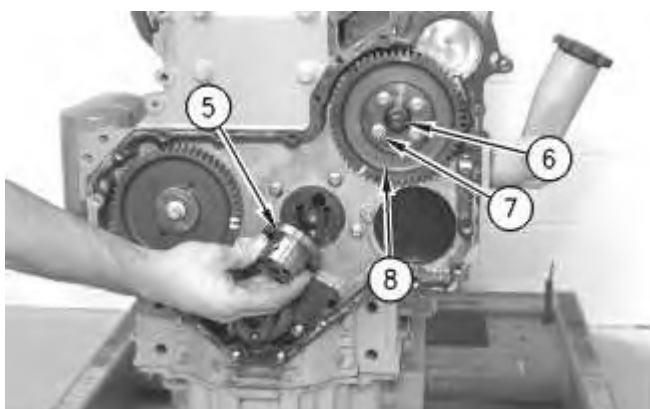

Illustration 1

g00556758

1. Install fuel injection pump gear (8) on the engine.
2. Install bolts (7) on fuel injection pump gear (8).

3. Install nut (6) and the spring washer on fuel injection pump gear (8). Tighten the nut to a torque of 80 N·m (59 lb ft).
4. Install idler gear hub (5) on the engine.



Illustration 2

g00556757

5. Use a suitable press to install new bushings (4) into idler gear (2).
6. Machine the bores for clearance on idler gear hub (5). The bore should have a clearance of 0.04 to 0.010 mm (0.0016 to 0.0039 inch) on idler gear hub (5). The bore can have a diameter of 57.14 to 57.18 mm (2.250 to 2.251 inch).
7. Machine the front faces of the bushings for the end play of idler gear (2). The gear and the bushings can have a thickness of 30.14 to 30.16 mm (1.186 to 1.187 inch).

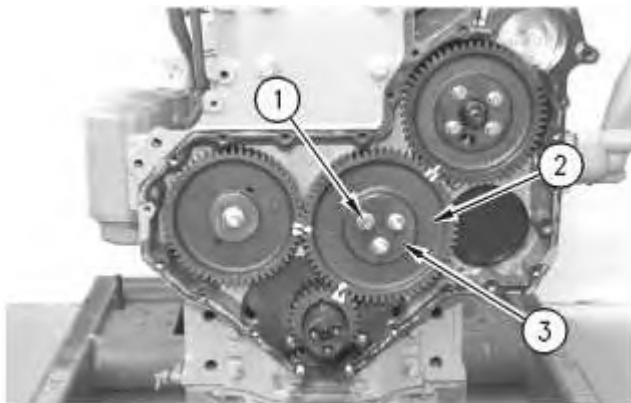

Illustration 3

g00556563

8. Install idler gear (2) and retainer plate (3) on the engine.  
**Note:** Ensure that the timing marks on the camshaft gear, the crankshaft gear, and the idler gear are aligned.
9. Install bolts (1) on idler gear (2). Tighten the bolts to a torque of 44 N·m (32 lb ft).
10. Check the end play of idler gear (2). Idler gear (2) should have end play of 0.10 to 0.20 mm (0.004 to 0.008 inch).

11. Check the backlash between the camshaft gear and idler gear (2). The gears must have a minimum backlash of 0.08 mm (0.003 inch).

**End By:**

- a. Install the front cover. Refer to Disassembly and Assembly, "Front Cover - Install".
-

Product: TELEHANDLER

Model: TH350B TELEHANDLER SLD

Configuration: TH350B Telehandler SLD00001-01640 (MACHINE) POWERED BY 3054E Engine

## **Disassembly and Assembly 3054 Engine for Caterpillar Built Machines**

Media Number -SEN6241-13

Publication Date -01/08/2008

Date Updated -04/08/2008

i01744128

### **Housing (Front) - Remove**

SMCS - 1151-011

### **Removal Procedure**

#### **Start By:**

- a. Remove the engine oil pan. Refer to Disassembly and Assembly, "Engine Oil Pan - Remove and Install".
- b. Remove the front gear group. Refer to Disassembly and Assembly, "Gear Group (Front) - Remove".
- c. Remove the camshaft gear. Refer to Disassembly and Assembly, "Camshaft Gear - Remove and Install".

---

#### **NOTICE**

**Keep all parts clean from contaminants.**

**Contaminants may cause rapid wear and shortened component life.**

---

---

#### **NOTICE**

**Care must be taken to ensure that fluids are contained during performance of inspection, maintenance, testing, adjusting and repair of the product. Be prepared to collect the fluid with suitable containers before opening any compartment or disassembling any component containing fluids.**

**Refer to Special Publication, NENG2500, "Caterpillar Dealer Service Tool Catalog" for tools and supplies suitable to collect and contain fluids on Caterpillar products.**

**Dispose of all fluids according to local regulations and mandates.**

---

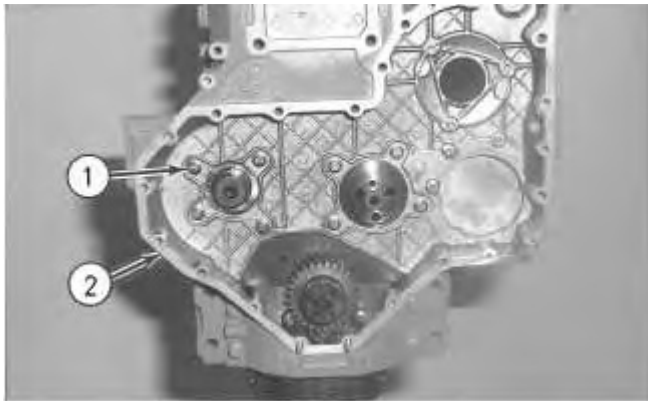

Illustration 1

g00549819

1. Remove all bolts (1) that fasten the front housing (2) to the cylinder block.



Illustration 2

g00549821

2. Remove bolts (3) that hold the oil pan to the bottom of front housing (2).
  3. Remove front housing (2) and the gasket.
-



Product: TELEHANDLER

Model: TH350B TELEHANDLER SLD

Configuration: TH350B Telehandler SLD00001-01640 (MACHINE) POWERED BY 3054E Engine

## Disassembly and Assembly 3054 Engine for Caterpillar Built Machines

Media Number -SEN6241-13

Publication Date -01/08/2008

Date Updated -04/08/2008

i06815567

## Housing (Front) - Install

SMCS - 1151-012

## Installation Procedure

Table 1

Required Tools			
Tool	Part Number	Part Description	Qty
A	-	Loctite Gasket Sealant No. 2	-

---

### NOTICE

**Keep all parts clean from contaminants.**

**Contaminants may cause rapid wear and shortened component life.**

---

1. Replace the gasket.
  2. Apply Tooling (A) to the bottom portion of the gasket.
-



---

Illustration 1

g00549821

3. If necessary, install the studs (not shown) to the back of the front housing (2) that holds the fuel injection pump in position. Tighten the studs to a torque of 11 N·m (97 lb in). Install the gasket and front housing (2). Cut the gasket to the correct length, if necessary.
4. Install bolts (3) that hold the engine oil pan to the bottom of the front housing. Tighten the bolts to a torque of 22 N·m (16 lb ft).

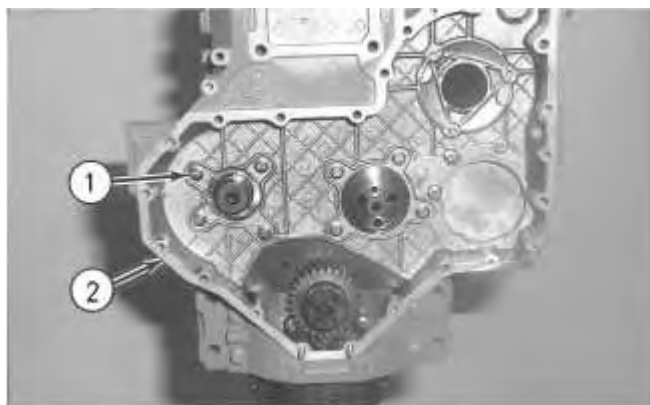

---

Illustration 2

g00549819

---

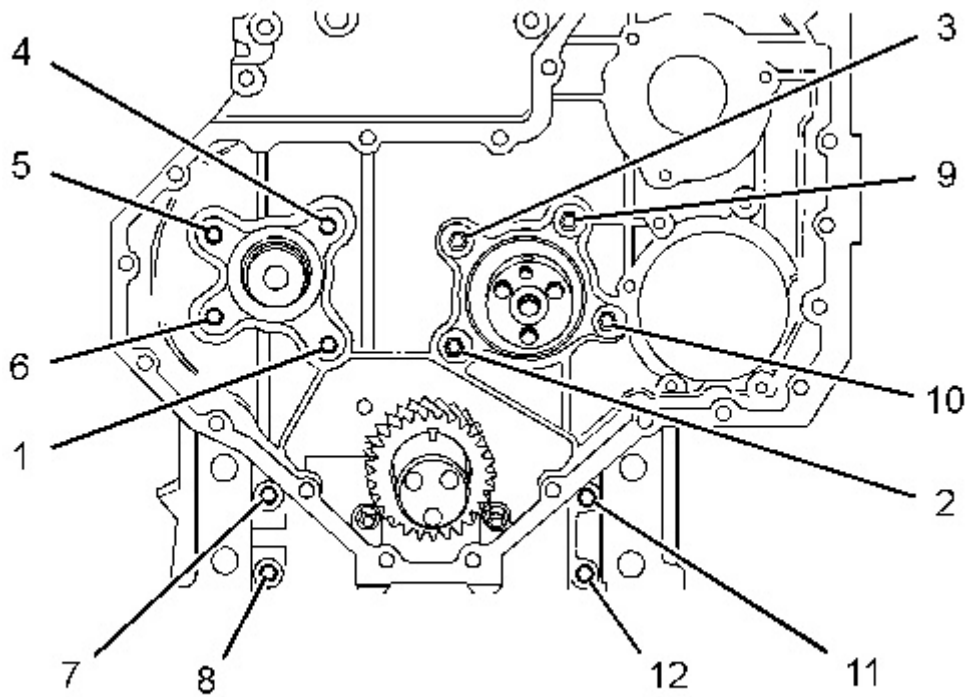

---

Illustration 3

g03549798

5. Install all bolts (1) that fasten the front housing (2) to the cylinder block and to the oil pan. Tighten bolts (1) to a torque of 22 N·m (16 lb ft) using the sequence in Illustration 3.

**Note:** Ensure that the bottom of the front housing is aligned with the bottom of the cylinder block.

**End By:**

- a. Install the camshaft gear.
  - b. Install the front gear group.
  - c. Install the engine oil pan.
-

Product: TELEHANDLER

Model: TH350B TELEHANDLER SLD

Configuration: TH350B Telehandler SLD00001-01640 (MACHINE) POWERED BY 3054E Engine

## **Disassembly and Assembly 3054 Engine for Caterpillar Built Machines**

Media Number -SEN6241-13

Publication Date -01/08/2008

Date Updated -04/08/2008

i01054405

# **Valve Mechanism Cover - Remove and Install**

SMCS - 1107-010

## **Removal Procedure**

---

### **NOTICE**

**Keep all parts clean from contaminants.**

**Contaminants may cause rapid wear and shortened component life.**

---

---

### **NOTICE**

**Care must be taken to ensure that fluids are contained during performance of inspection, maintenance, testing, adjusting and repair of the product. Be prepared to collect the fluid with suitable containers before opening any compartment or disassembling any component containing fluids.**

**Refer to Special Publication, NENG2500, "Caterpillar Tools and Shop Products Guide" for tools and supplies suitable to collect and contain fluids on Caterpillar products.**

**Dispose of all fluids according to local regulations and mandates.**

---

**Note:** The engines are equipped with either an aluminum valve cover or with a composite valve cover. The aluminum valve cover has a seal that fits between the valve cover and the inlet

manifold. The composite valve cover has a seal that is permanently fixed to the side of the valve cover.

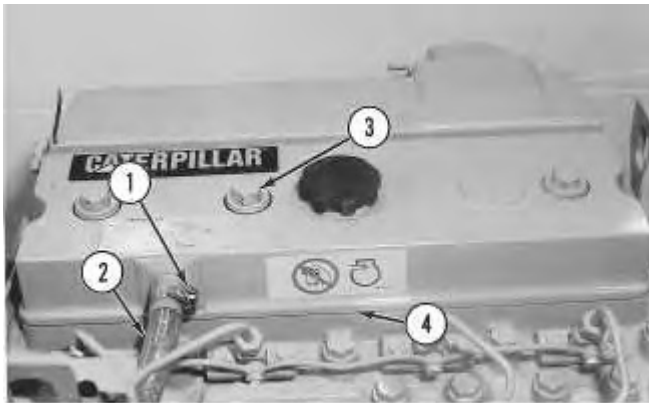

Illustration 1

g00547002

Typical example

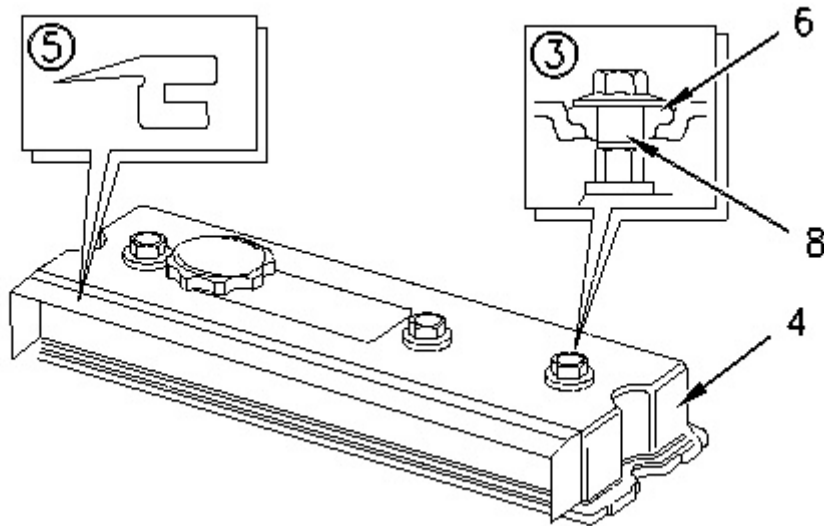

Illustration 2

g00547003

Aluminum valve cover

---

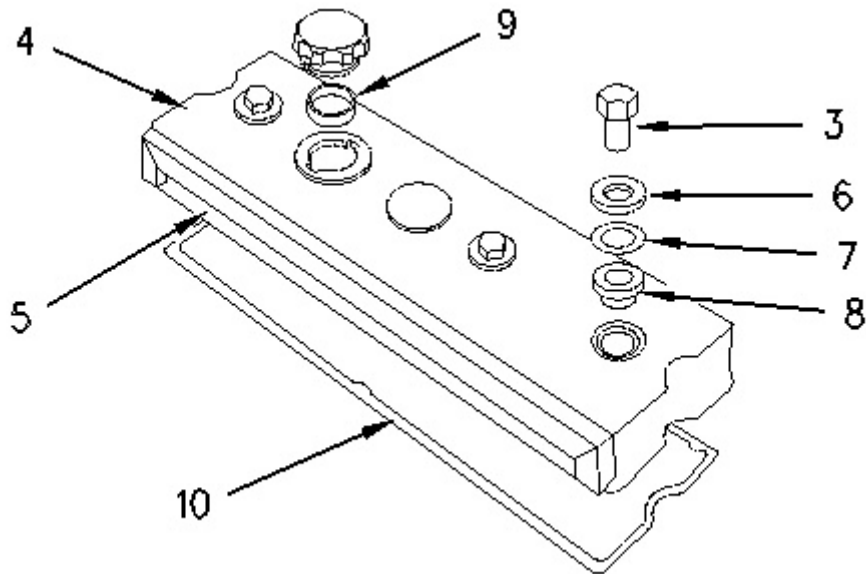

Illustration 3

g00547004

Composite valve cover

1. Loosen hose clamp (1) .
2. Disconnect breather hose (2) .
3. Remove three nuts (3), steel washers (6), and sealing washers (8) .

**Note:** When you remove nuts (3), ensure that the nuts on the rocker arm bracket are not loosened.

**Note:** Current production engines have an additional shim washer (7) .

4. Remove valve cover (4), gasket (10), and seal (5) .
5. Remove seal (9) for the oil filler cap.

## Installation Procedure

**Note:** The engines are equipped with either an aluminum valve cover or with a composite valve cover. The aluminum valve cover has a seal that fits between the valve cover and the inlet manifold. The composite valve cover has a seal that is permanently fixed to the side of the valve cover.

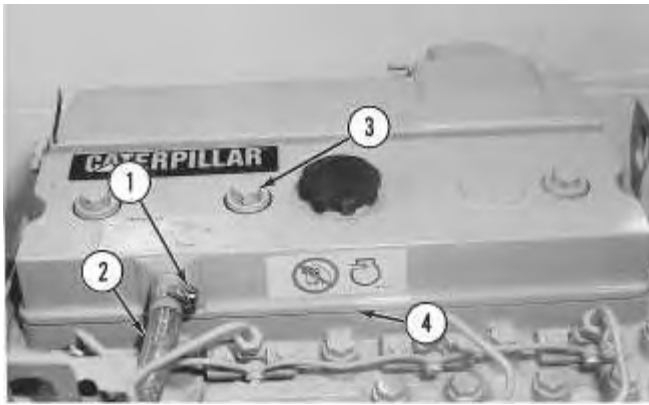

Illustration 4

g00547002

Typical example

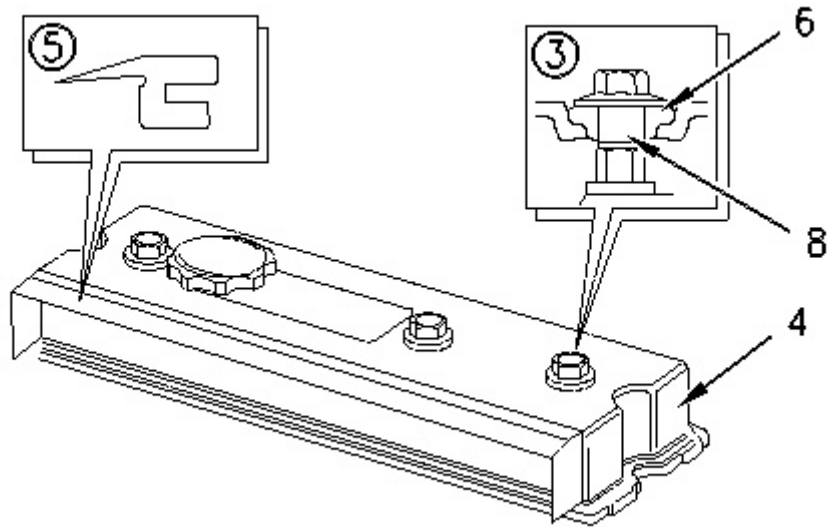

Illustration 5

g00547003

Aluminum valve cover

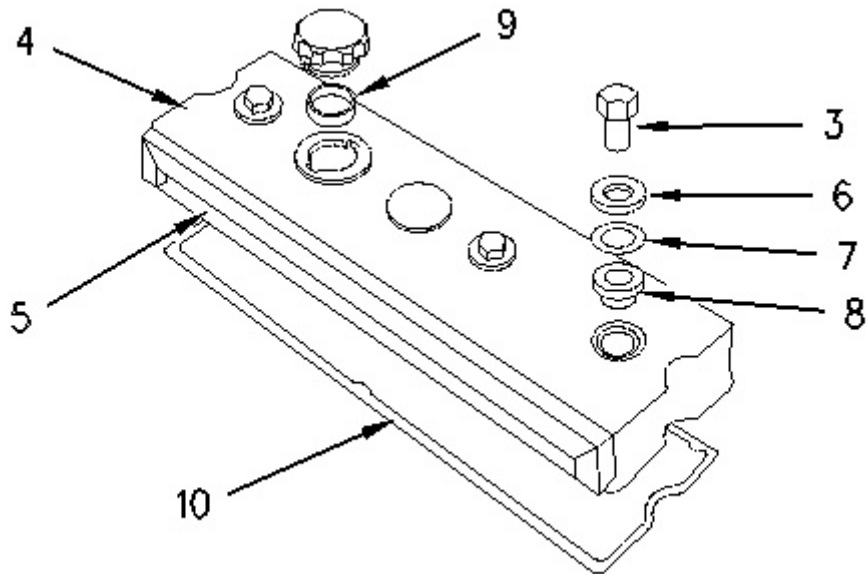

Illustration 6

g00547004

Composite valve cover

1. Inspect the condition of the gaskets and the seals. Replace the gaskets and the seals, if necessary.
2. Install seal (9) for the oil filler cap, if necessary.
3. Apply **8T-9022** Silicone Gasket to gasket (10) .

**Note:** Ensure that the flat face of the gasket is toward the valve cover.

4. Install gasket (10), seal (5), and valve cover (4) .
5. Lubricate three nuts (3) with clean engine oil.
6. Install three nuts (3), steel washers (6), and sealing washers (8) .

**Note:** When you install three nuts (3) without shim washers (7), tighten the nuts to a torque of 20 N·m (15 lb ft). Do not overtighten the nuts.

**Note:** When you install three nuts (3) with shim washers (7), tighten the nuts to a torque of 30 N·m (22 lb ft). Do not overtighten the nuts.

7. Connect breather hose (2) .
8. Tighten hose clamp (1) .



Product: TELEHANDLER

Model: TH350B TELEHANDLER SLD

Configuration: TH350B Telehandler SLD00001-01640 (MACHINE) POWERED BY 3054E Engine

## Disassembly and Assembly 3054 Engine for Caterpillar Built Machines

Media Number -SEN6241-13

Publication Date -01/08/2008

Date Updated -04/08/2008

i01761173

# Rocker Shaft and Pushrod - Remove

SMCS - 1102-011; 1208-011

## Removal Procedure

### Start By:

- a. Remove the valve mechanism cover. Refer to Disassembly and Assembly, "Valve Mechanism Cover - Remove and Install".

---

### NOTICE

**Keep all parts clean from contaminants.**

**Contaminants may cause rapid wear and shortened component life.**

---

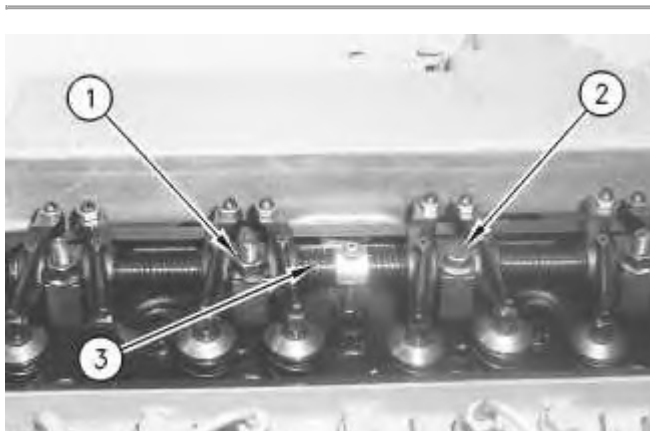

Illustration 1

g00635152

Typical example

**Note:** It is not necessary to remove the oil supply tube in order to remove the rocker shaft assembly and the pushrods.

1. Remove nuts (1) and bolt (2) from the rocker shaft assembly. Begin with the end brackets and move toward the center.
2. Remove rocker shaft assembly (3).
3. Remove the oil seal from the oil supply passage in the cylinder head.

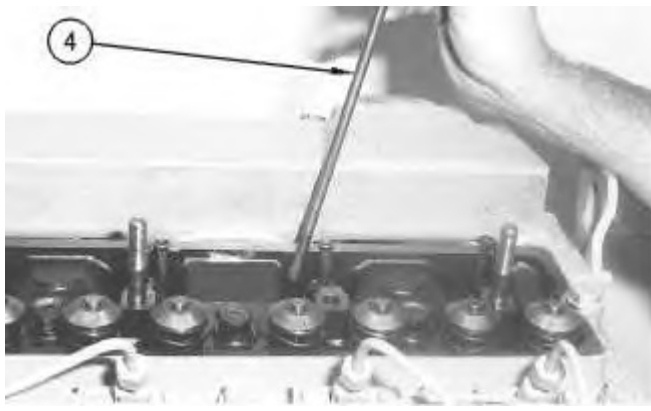

Illustration 2

g00635153

Typical example

4. Remove pushrods (4). Place an identification mark on the pushrods for installation.
-

Product: TELEHANDLER

Model: TH350B TELEHANDLER SLD

Configuration: TH350B Telehandler SLD00001-01640 (MACHINE) POWERED BY 3054E Engine

## Disassembly and Assembly 3054 Engine for Caterpillar Built Machines

Media Number -SEN6241-13

Publication Date -01/08/2008

Date Updated -04/08/2008

i01667090

### Rocker Shaft - Disassemble

SMCS - 1102-015

### Disassembly Procedure

Table 1

Required Tools			
Tool	Part Number	Part Description	Qty
A	1P-0510	Driver Group	1

#### Start By:

- A. Remove the rocker shaft assembly. Refer to Disassembly and Assembly, "Rocker Shaft and Pushrod - Remove".



Illustration 1

g00550061

1. Use a screwdriver or a similar tool to remove retaining ring (1) from both ends of the rocker shaft assembly.

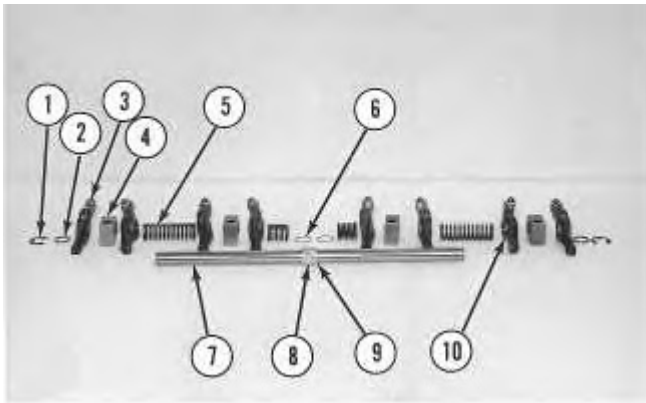

Illustration 2

g00550062

- (1) Retaining ring
  - (2) Washer on the end of the rocker shaft
  - (3) Rocker arm assembly
  - (4) Rocker shaft bracket
  - (5) Spring on the rocker shaft
  - (6) Washer
  - (7) Rocker shaft
  - (8) Bolt
  - (9) Oil supply connection
  - (10) Rocker arm bushing
2. Remove the rocker arms and the rocker shaft brackets from the rocker shaft assembly.  
**Note:** Place an identification mark on each of the components for the proper order for installation.
  3. Check the clearance between rocker arm assembly (3) and rocker shaft (7). Replace rocker arm bushing (10) if the clearance is larger than 0.13 mm (0.005 inch). Use Tool (A) and a suitable press in order to remove rocker arm bushing (10) from rocker arm assembly (3), if necessary.
  4. Remove rocker shaft bracket (4) from rocker shaft (7) .
  5. Remove springs (5), washer (6), bolt (8) and oil supply connection (9) from rocker shaft (7) .
-

Product: TELEHANDLER

Model: TH350B TELEHANDLER SLD

Configuration: TH350B Telehandler SLD00001-01640 (MACHINE) POWERED BY 3054E Engine

## Disassembly and Assembly 3054 Engine for Caterpillar Built Machines

Media Number -SEN6241-13

Publication Date -01/08/2008

Date Updated -04/08/2008

i01667093

### Rocker Shaft - Assemble

SMCS - 1102-016

### Assembly Procedure

1. Lubricate all of the components with clean engine oil.

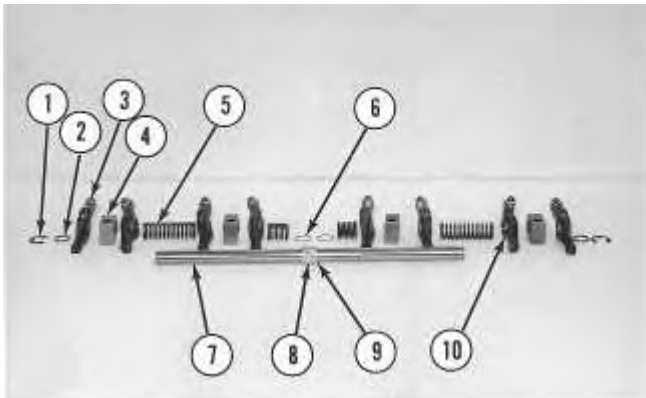

Illustration 1

g00550062

- (1) Retaining ring
- (2) Washer on the end of the rocker shaft
- (3) Rocker arm assembly
- (4) Rocker shaft bracket
- (5) Spring on the rocker shaft
- (6) Washer
- (7) Rocker shaft

- (8) Bolt
- (9) Oil supply connection
- (10) Rocker arm bushing

2. Install oil supply connection (9) and bolt (8) on rocker shaft (7) .

**Note:** Ensure that the bolt and the connection are correctly positioned on the rocker shaft.

**Note:** Ensure that all of the oil holes in the rocker shaft and in the rocker arms are not plugged before you begin the assembly procedure.

3. Install rocker arm bushing (10) in rocker arm assembly (3) with a suitable press. Ream the bushing to a clearance of  $0.06 \pm 0.03$  mm ( $0.0024 \pm 0.0012$  inch), if necessary.
4. Install each of the components in the correct order onto rocker shaft (7). See Illustration 1.



Illustration 2

g00550061

5. Install retaining ring (1).

**End By:** Install the rocker shaft assembly. Refer to Disassembly and Assembly, "Rocker Shaft and Pushrod - Install".

---

Product: TELEHANDLER

Model: TH350B TELEHANDLER SLD

Configuration: TH350B Telehandler SLD00001-01640 (MACHINE) POWERED BY 3054E Engine

## Disassembly and Assembly 3054 Engine for Caterpillar Built Machines

Media Number -SEN6241-13

Publication Date -01/08/2008

Date Updated -04/08/2008

i01749382

# Rocker Shaft and Pushrod - Install

SMCS - 1102-012; 1208-012

## Installation Procedure

---

### NOTICE

**Keep all parts clean from contaminants.**

**Contaminants may cause rapid wear and shortened component life.**

---



Illustration 1

g00635153

Typical example

1. Install pushrods (4).

**Note:** Ensure that the pushrods are installed in the original location and that the pushrods are seated in the valve lifters correctly.

2. Install a new oil seal in the oil supply hole in the cylinder head.

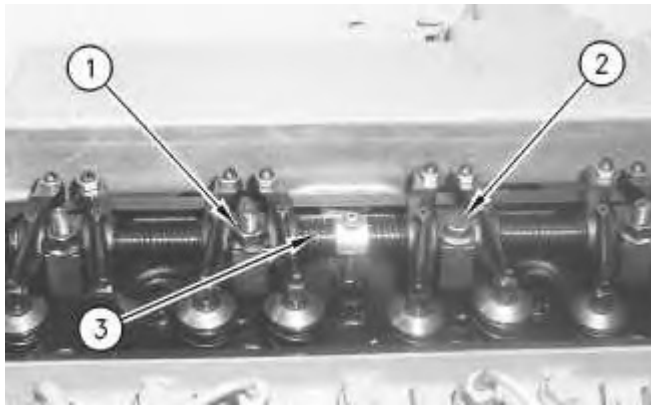

Illustration 2

g00635152

Typical example

3. Put rocker shaft assembly (3) in position on the cylinder head. Make sure that the connection for the oil supply is installed correctly into the oil seal.

**Note:** Ensure that the adjustment screws are properly seated in the ends of pushrods (4).

**Note:** It may be necessary to loosen the adjustment screws on each rocker arm. This will help prevent a bent valve or a bent pushrod during the installation of the rocker shaft.

4. Lubricate nuts (1) and bolt (2) with clean engine oil.
5. Install nuts (1) and bolt (2).
6. Alternately tighten the nuts and the bolt. Start from the center and work toward the outside. Tighten the nuts and the bolt on an aluminum bracket to a torque of 40 N·m (30 lb ft). Tighten the nuts and the bolt on a cast iron or a steel bracket to a torque of 75 N·m (55 lb ft).
7. Adjust the inlet valve lash to 0.20 mm (0.008 inch) and adjust the exhaust valve lash to 0.45 mm (0.018 inch). Refer to Testing and Adjusting, "Air Inlet and Exhaust System" for more information on adjusting the valve lash.

**End By:**

- a. Install the valve mechanism cover. Refer to Disassembly and Assembly, "Valve Mechanism Cover - Remove and Install".
-



Thank you so much for reading.  
Please click the “Buy Now!”  
button below to download the  
complete manual.



After you pay.

You can download the most  
perfect and complete manual in  
the world immediately.

Our support email:

[ebooklibonline@outlook.com](mailto:ebooklibonline@outlook.com)