

Product: TELEHANDLER

Model: TH355B TELEHANDLER JRK

Configuration: TH355B TH360B Telehandler JRK00001-UP (MACHINE) POWERED BY 3054E Engine

Disassembly and Assembly

TH350B, TH355B, TH360B, TH460B and TH560B Telehandlers Power Train

Media Number -REN5186-06

Publication Date -01/07/2008

Date Updated -01/08/2008

i02012170

Transmission - Disassemble

SMCS - 3030-015

Disassembly Procedure

Start By:

- A. Remove the transmission. Refer to Disassembly and Assembly, "Transmission - Remove".
- B. Remove the torque converter. Refer to Disassembly and Assembly, "Torque Converter - Disassemble".

Table 1

Required Tools			
Tool	Part Number	Part Description	Qty
A	138-7575	Link Bracket	2
B	1U-7262	Telescoping Magnet	1
C	1U-8241	Lifting Sling	1
D	1P-2320	Combination Puller	1
E	138-7573	Link Bracket	3
F	1P-1857	Retaining Ring Pliers	1
G	156-7100	Slide Hammer Puller Gp	1
H	1P-0510	Driver Gp	1
I	1P-1856	Retaining Ring Pliers	1
J	1P-2321	Combination Puller	1
K	4C-8359	Eyebolt (M12)	1

L	1P-1860	Retaining Ring Pliers	1
M	8B-7550	Push-Puller Leg	1
	8H-0663	Bearing Puller Gp	1
N	1P-0074	Slide Hammer Puller Gp	1

 **WARNING**

Personal injury or death can result from improper lifting or blocking.

When a hoist or jack is used to lift any part or component, stand clear of the area. Be sure the hoist or jack has the correct capacity to lift a component. Install blocks or stands before performance of any work under a heavy component.

Approximate weights of the components are shown. Clean all surfaces where parts are to be installed.

NOTICE

Care must be taken to ensure that fluids are contained during performance of inspection, maintenance, testing, adjusting and repair of the product. Be prepared to collect the fluid with suitable containers before opening any compartment or disassembling any component containing fluids.

Refer to Special Publication, NENG2500, "Caterpillar Tools and Shop Products Guide" for tools and supplies suitable to collect and contain fluids on Caterpillar products.

Dispose of all fluids according to local regulations and mandates.

NOTICE

Keep all parts clean from contaminants.

Contaminants may cause rapid wear and shortened component life.

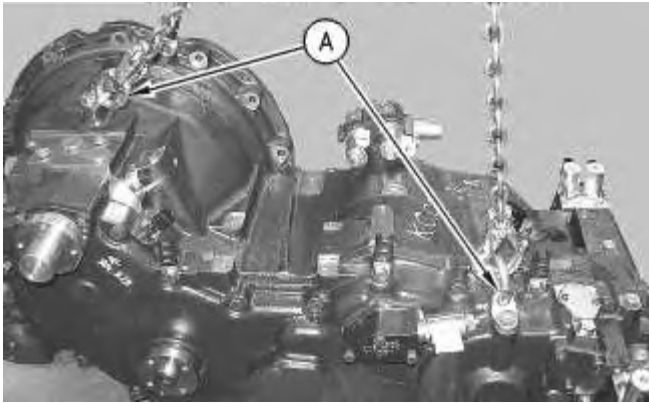

Illustration 1

g00892840

1. Attach Tooling (A) and a suitable lifting device to the transmission and position the transmission onto a suitable bench. The weight of the transmission is approximately 350 kg (772 lb).

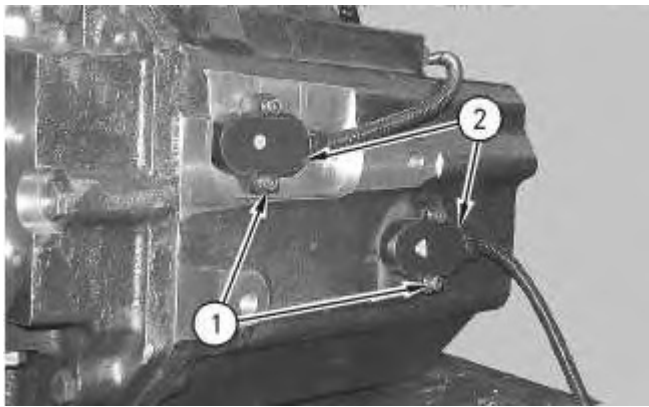

Illustration 2

g00893165

2. Use a suitable allen wrench to remove allen head screws (1) in order to remove sensors (2) for the shift rails.
 3. Machines that are equipped with five speeds have additional components that need to be removed.
-

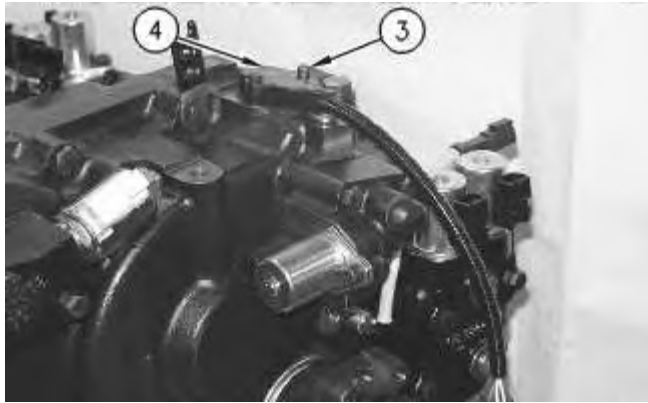

Illustration 3

g00895246

 **WARNING**

Personal injury can result from being struck by parts propelled by a released spring force.

Make sure to wear all necessary protective equipment.

Follow the recommended procedure and use all recommended tooling to release the spring force.

- a. Use a suitable allen wrench to remove two allen head screws (3) in order to remove sensor (4) for the shift rail.



Illustration 4

g00895262

 **WARNING**

Personal injury can result from being struck by parts propelled by a released spring force.

Make sure to wear all necessary protective equipment.

Follow the recommended procedure and use all recommended tooling to release the spring force.

- b. Use a suitable allen wrench in order to remove cap (5) .

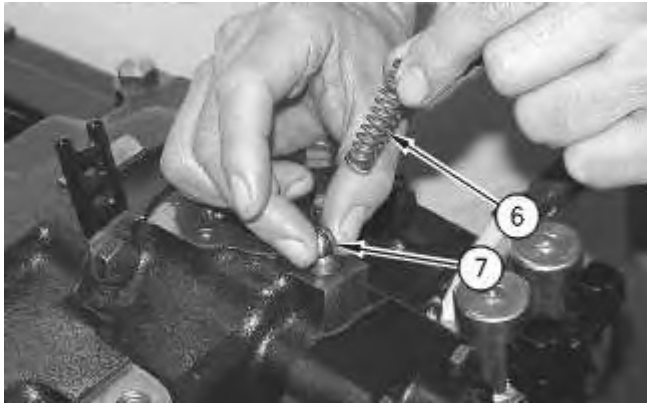

Illustration 5

g00895720

! WARNING

Personal injury can result from being struck by parts propelled by a released spring force.

Make sure to wear all necessary protective equipment.

Follow the recommended procedure and use all recommended tooling to release the spring force.

- c. Remove spring (6). Use Tooling (B) (not shown) in order to remove detent ball (7) from the transmission.
-

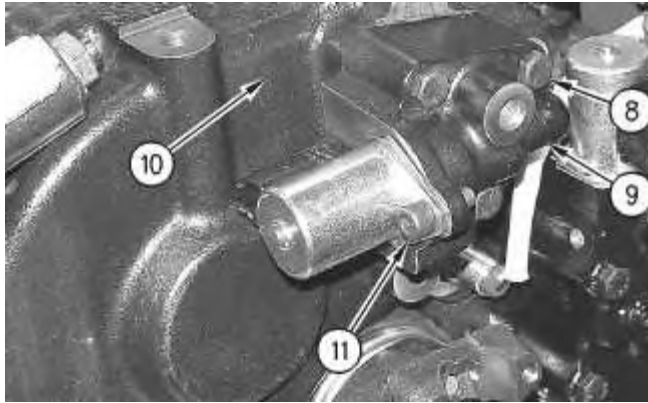

Illustration 6

g00895742

- d. Remove bolts (8) that secure actuator (9) to transmission cover (10). Remove the actuator from the transmission cover and take care not to lose the two O-ring seals that are between the actuator and the transmission cover.

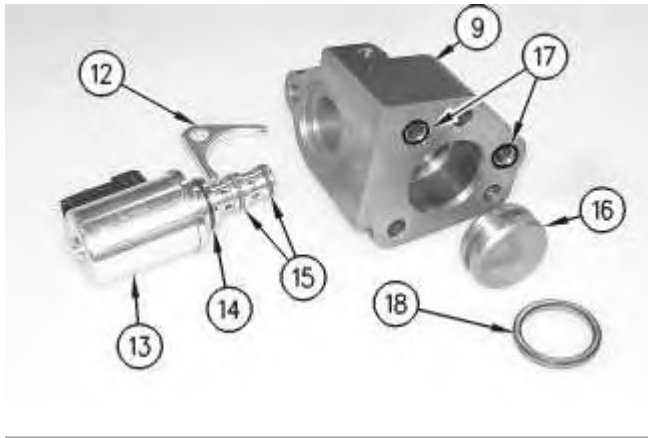

Illustration 7

g00892932

- e. Remove allen head screw (11) that is shown in Illustration 6. Remove locking plate (12) in order to remove solenoid (13) from actuator (9). Remove O-ring seals (14) and (15) from the spool and inspect the O-ring seals for damage. Replace the O-ring seals, if necessary.
 - f. Remove actuator piston (16) from the actuator, and remove O-ring seals (17) and (18). Inspect the O-ring seals for damage and replace the O-ring seals, if necessary.
-

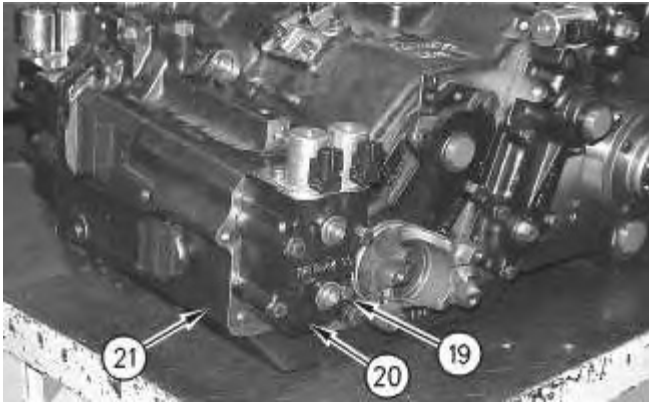

Illustration 8

g00892825

4. Remove bolts (19) that secure actuator (20) to transmission housing (21). Remove the actuator from the transmission housing and take care not to lose the four O-ring seals that are between the actuator and the transmission housing.

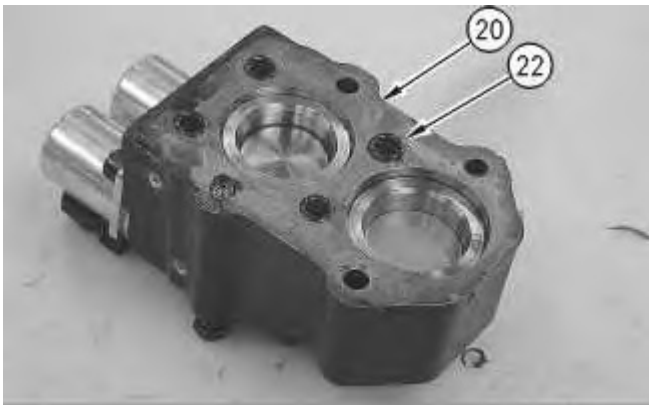
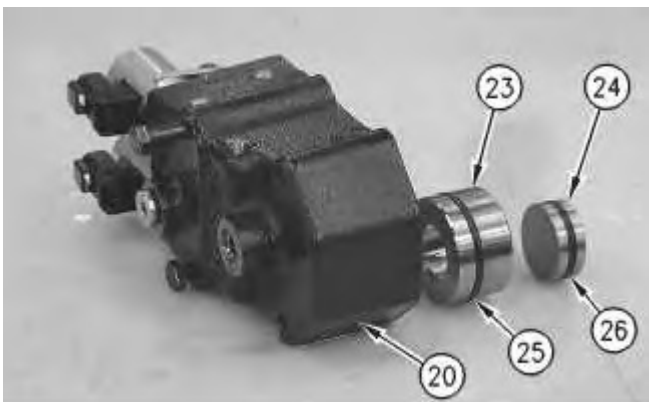

Illustration 9

g00892853

5. Remove O-ring seals (22) from actuator (20) and inspect the O-ring seals for damage. Replace the O-ring seals, if necessary.



6. Remove neutralizing piston (23), and actuator piston (24) from actuator (20). Remove O-ring seals (25) and (26) from the pistons and inspect the O-ring seals for damage. Replace the O-ring seals, if necessary.

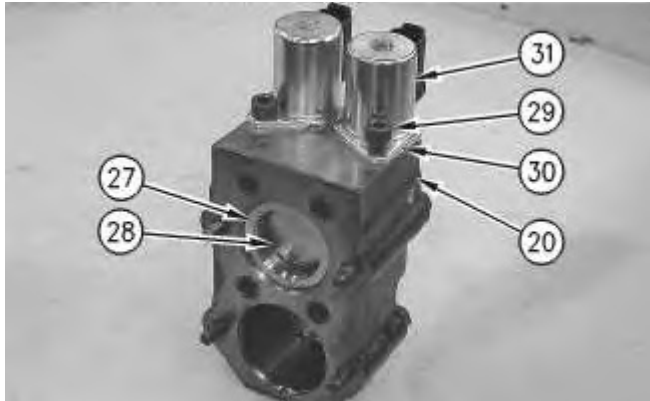

Illustration 11

7. Repeat Step 6 for neutralizing piston (27) and actuator piston (28) .
8. Remove allen head screw (29) and locking plate (30) in order to remove solenoid (31) from actuator (20) .

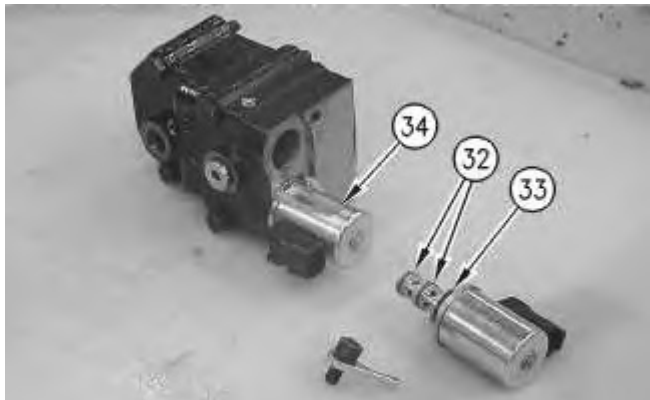

Illustration 12

9. Remove O-ring seals (32) and (33) from the spool and inspect the O-ring seals for damage. Replace the O-ring seals, if necessary.
 10. Repeat Step 8 and Step 9 for solenoid (34) .
-

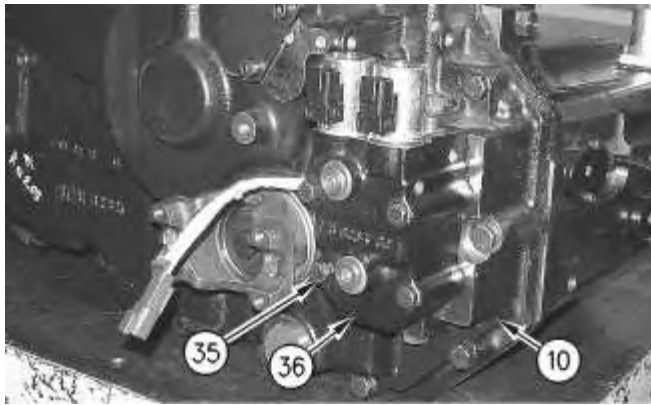

Illustration 13

g00892810

11. Remove bolts (35) that secure actuator (36) to transmission cover (10). Remove the actuator from the transmission cover and take care not to lose the four O-ring seals that are between the actuator and the transmission cover.
12. Repeat Step 5 to Step 10 for actuator (36) .

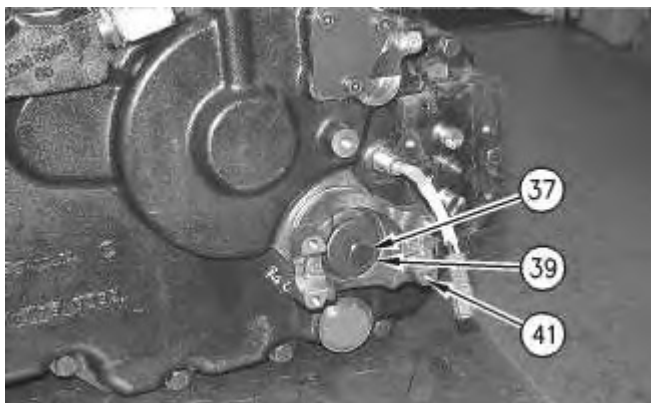

Illustration 14

g00893163

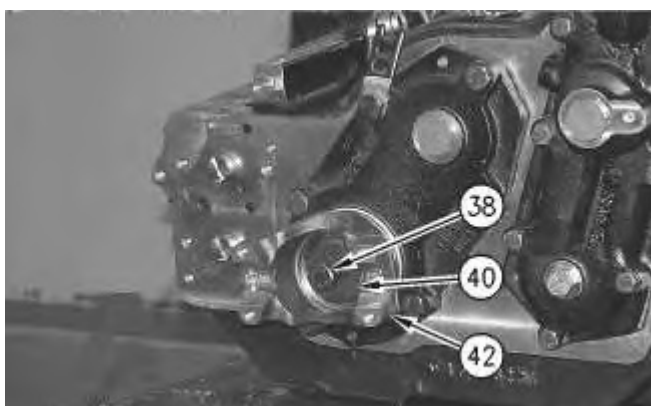

Illustration 15

g00893164

13. Remove bolts (37) and (38) and washers (39) and (40) in order to remove drive yokes (41) and (42) from both ends of the output shaft.

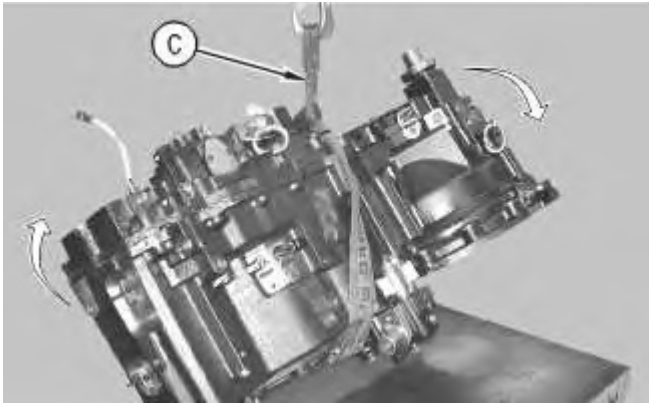

Illustration 16

g00893166

14. Attach Tooling (C) around the middle of the transmission and take care not to stress any of the solenoids. Use Tooling (C) and a suitable lifting device in order to carefully lift the transmission. The weight of the transmission is approximately 350 kg (772 lb).



Illustration 17

g00893167

15. Position suitable cribbing in order to support each end of the transmission. Ensure that the cribbing allows clearance between valve housing (43) and the bench. Lower the transmission in the orientation that is shown in Illustration 17.
-

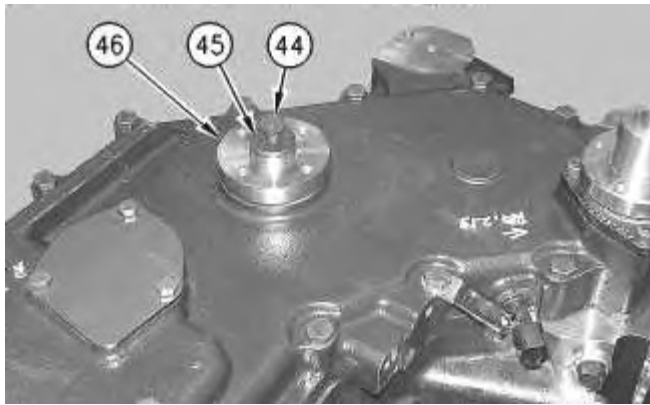

Illustration 18

g00893168

16. Remove bolt (44) and washer (45) in order to remove fan drive (46) from the fan drive shaft.

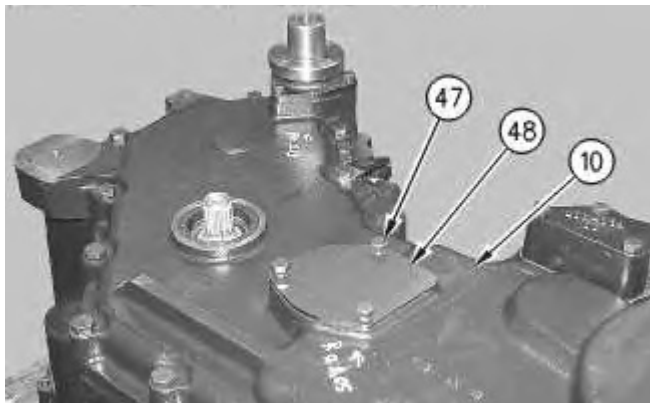

Illustration 19

g00893171

17. Remove bolts (47) in order to remove access panel (48) from transmission cover (10) .

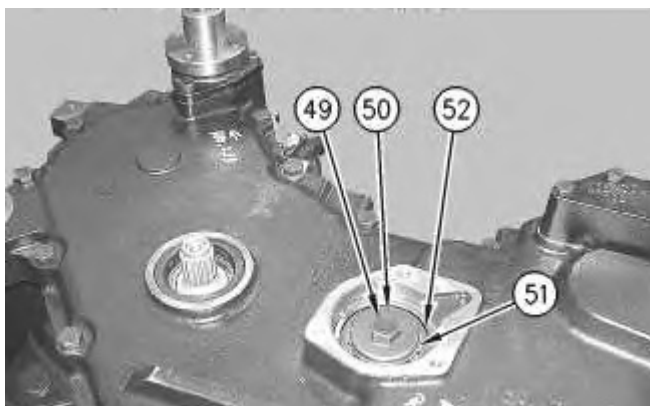

Illustration 20

g00893172

18. Remove bolt (49) and washer (50) from the pump drive shaft. Remove ring (51) from the top of roller bearing (52) .

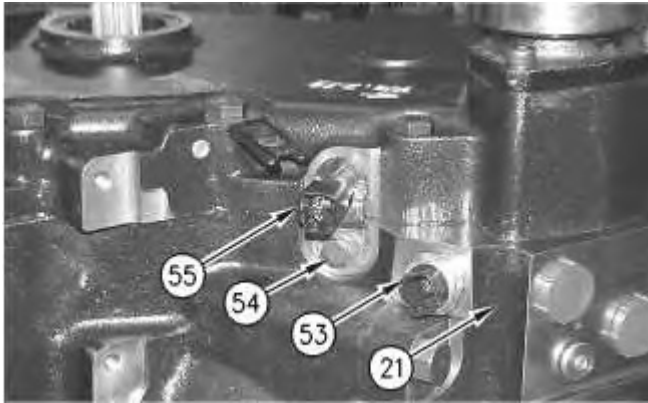

Illustration 21

g00893173

19. Remove temperature sensor (53) from transmission housing (21) .
20. Remove bolt (54) in order to remove speed sensor (55) .

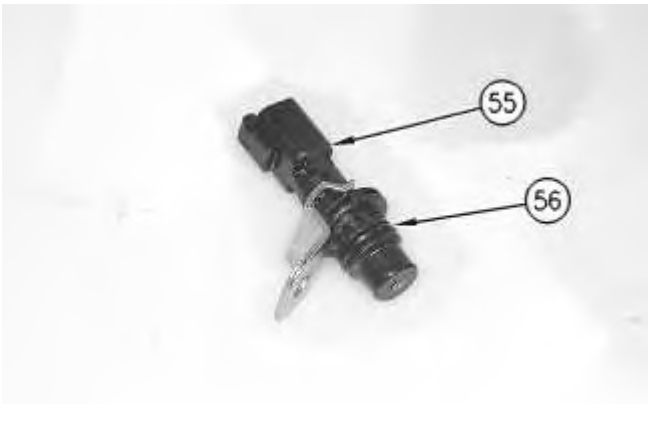

Illustration 22

g00896588

21. Remove O-ring seal (56) from speed sensor (55) and inspect the O-ring seal for damage. Replace the O-ring seal, if necessary.
-

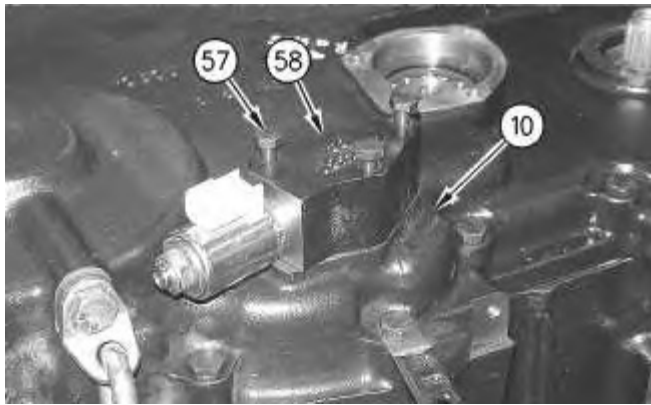

Illustration 23

g00893174

22. Remove bolts (57) that secure modulating valve (58) to transmission cover (10). Remove the modulating valve from the transmission cover and take care not to lose the three O-ring seals that are between the modulating valve and the transmission cover.

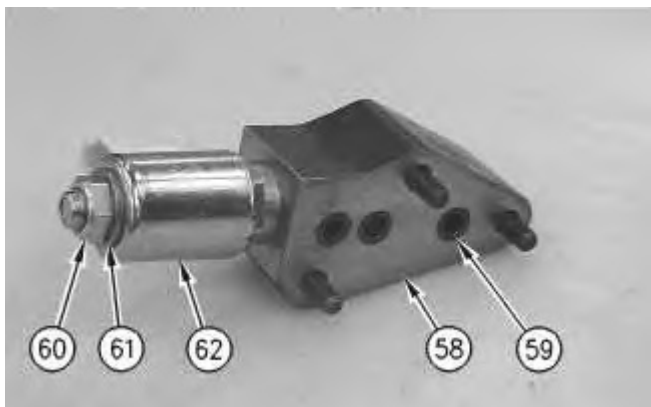
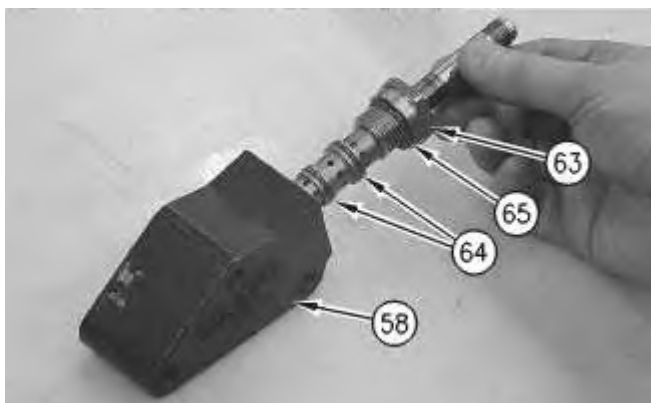

Illustration 24

g00893176

23. Remove O-ring seals (59) from modulating valve (58) and inspect the O-ring seals for damage. Replace the O-ring seals, if necessary. Remove nut (60) and washer (61) in order to remove solenoid (62) .



24. Remove spool (63) from modulating valve (58). Remove O-ring seals (64) and (65) from the valve spool and inspect the O-ring seals for damage. Replace the O-ring seals, if necessary.

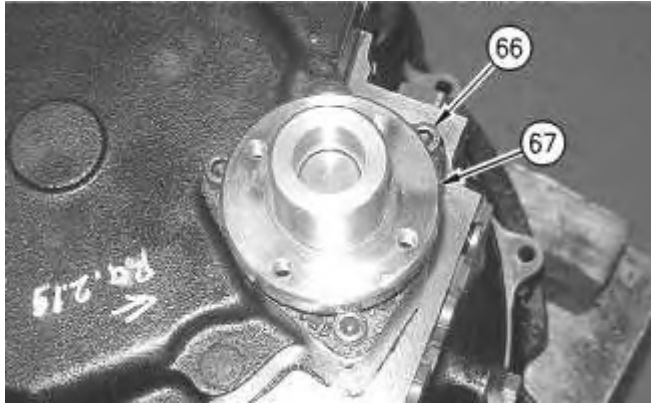

Illustration 26

25. Remove allen head screws (66) in order to remove idler (67) for the fan drive.



Illustration 27



Illustration 28

g00893259

26. Use a suitable press in order to take the load off snap ring (68) that secures bearing (69) and remove the snap ring.



Illustration 29

g00893302

27. Use a suitable spring compressor in order to press the bearing from mounting flange (70) .

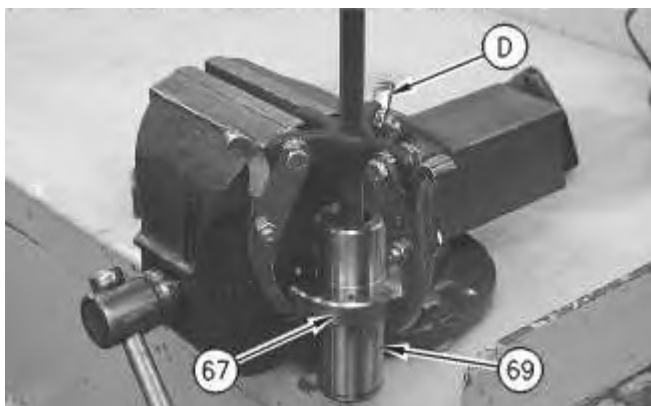

Illustration 30

g00893317

28. Use Tooling (D) and a suitable bench vise in order to remove bearing (69) from idler (67) .

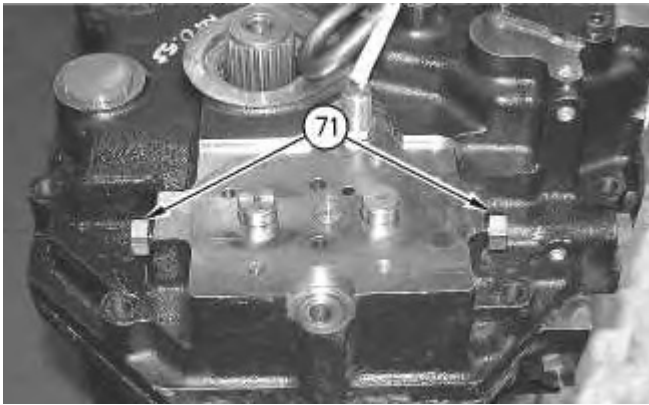

Illustration 31

g00893374

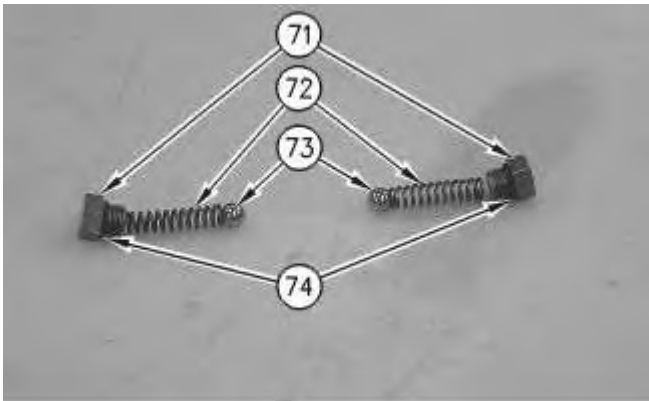

Illustration 32

g00893387

WARNING

Personal injury can result from being struck by parts propelled by a released spring force.

Make sure to wear all necessary protective equipment.

Follow the recommended procedure and use all recommended tooling to release the spring force.

29. Remove spring retainers (71), springs (72) and detent balls (73). Use a Tooling (B) in order to remove the two detent balls from the transmission housing. Remove O-ring seals (74) from spring retainers (71) and inspect the O-ring seals for damage. Replace the O-ring seals, if necessary.

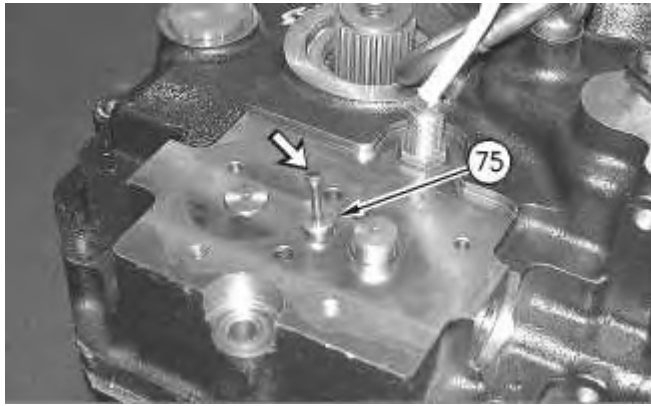

Illustration 33

g00893598

30. Use a suitable M4 screw to remove cap (75) .

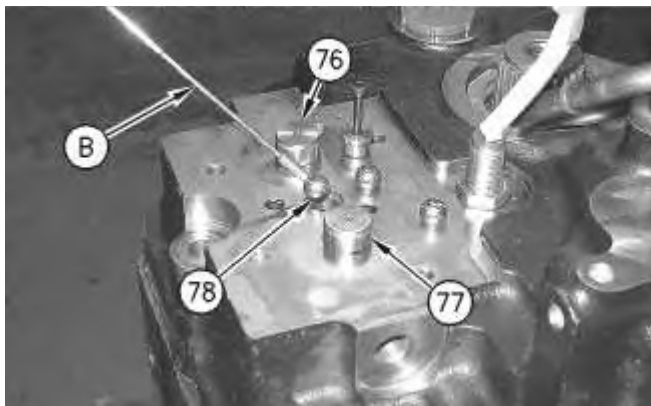
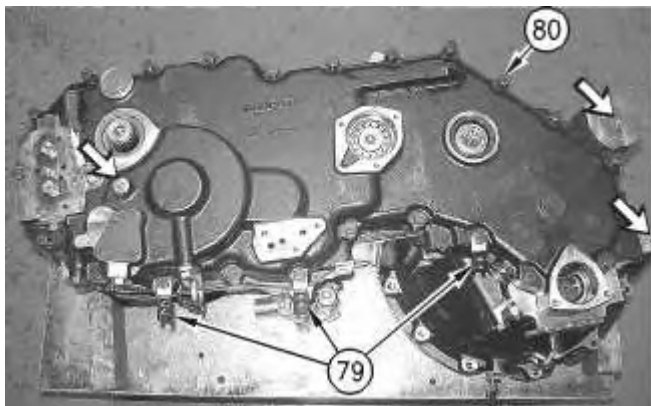

Illustration 34

g00893599

31. Make sure that shift rail (76) and shift rail (77) are in the NEUTRAL position. Use Tooling (B) in order to remove four detent balls (78) from the cavity.



Note: Record the positions of three supports (71) for the harness before removing 22 bolts (80) .

32. Remove 22 bolts (80) that secure the transmission cover to the transmission housing.
33. Attach Tooling (E) to the three 10 mm holes that are shown in Illustration 35.

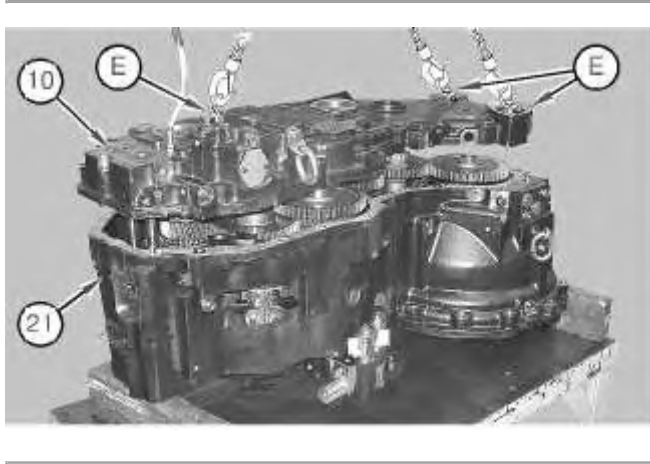

Illustration 36

g01040523

34. Use Tooling (E) and a suitable lifting device in order to lift transmission cover (10). The weight of the transmission cover is approximately 42 kg (93 lb). Lift the transmission cover away from transmission housing (21) .

Note: Ensure that the transmission cover is lifted square in order to smoothly disengage the two locating pins that are between the interface of the transmission cover and the transmission housing.

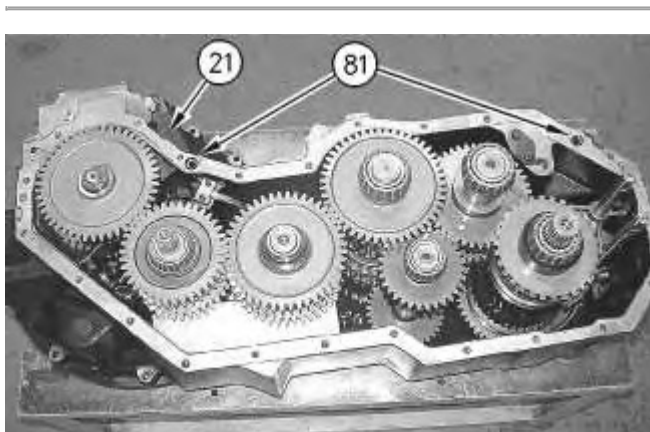

Illustration 37

g00893602

35. Remove O-ring seals (81) from transmission housing (21) and inspect the O-ring seals for damage. Replace the O-ring seals, if necessary.

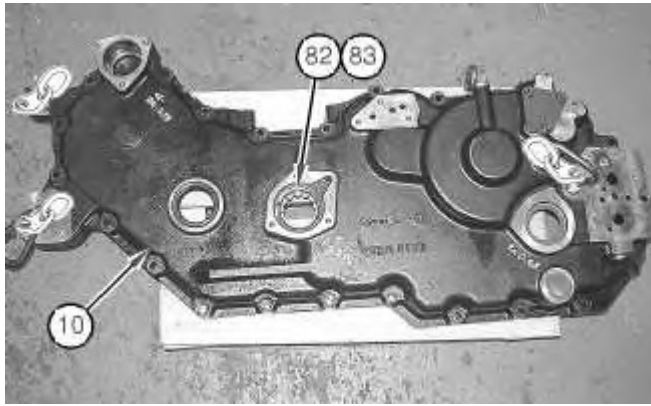

Illustration 38

g01040762

36. Use Tooling (F) in order to remove circlip (82). Remove bearing (83) for the pump drive shaft from transmission cover (10) .



Illustration 39

g00895559

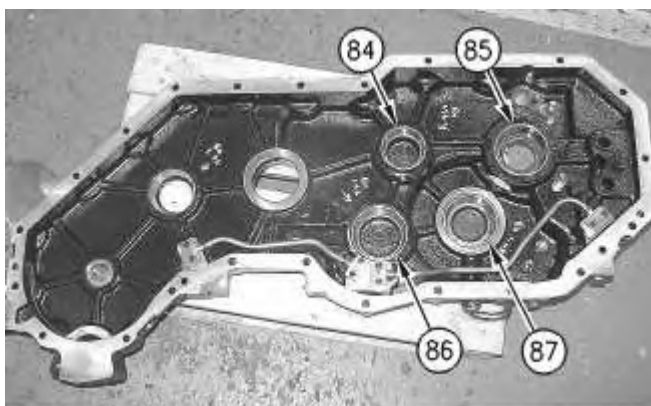

Illustration 40

g00895560

37. Use Tooling (G) to remove four bearing sleeves (84), (85), (86) and (87). Remove any shims that are under the bearing sleeves.

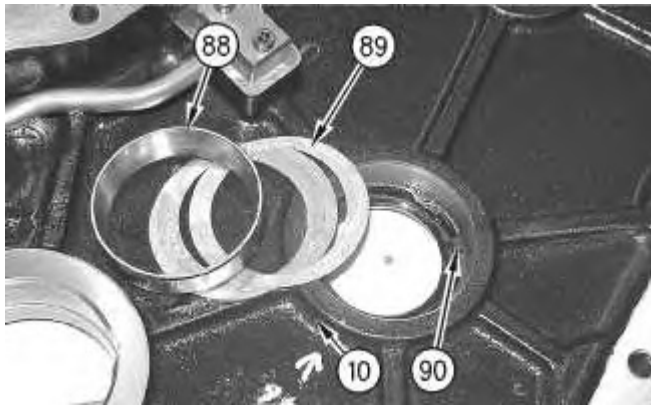

Illustration 41

g00895562

38. Use Tooling (G) in order to remove bearing sleeve (88) for the fan drive shaft from transmission cover (10). Remove shims (89), and use Tooling (F) in order to remove circlip (90).



Illustration 42

g00895563

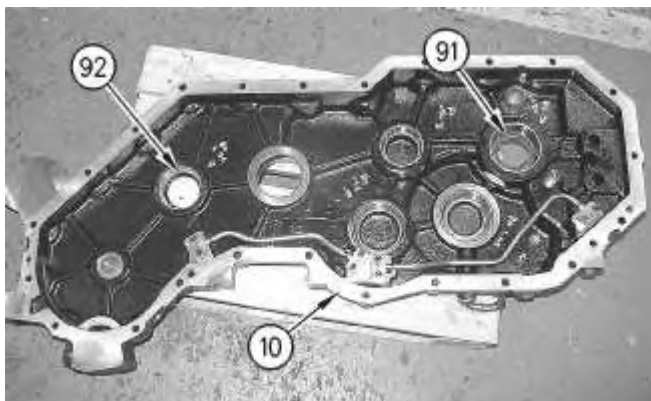

39. Use Tooling (H) in order to remove two seals (91) and (92) from transmission cover (10). Inspect the two seals for damage and replace the seals, if necessary.

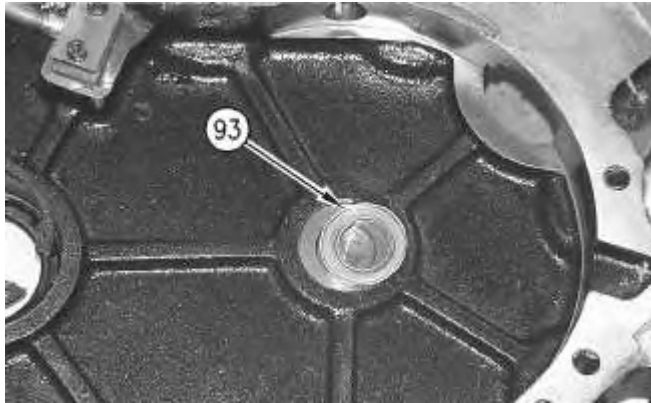

Illustration 44

g00895566

40. Remove bearing carrier (93) for the input shaft and inspect the bearing carrier. Replace the bearing carrier, if necessary.

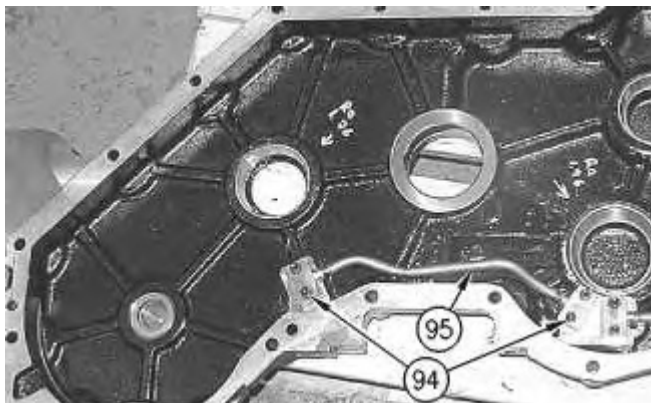

Illustration 45

g00895658

41. Remove four allen head screws (94) in order to remove oil tube (95) .

Note: There is an O-ring seal at both ends of the oil tube. Inspect each seal and replace the seals, if necessary.

42. Remove the other oil tube from the transmission cover. The position of the oil tube in a transmission with five speeds is different to the position of the oil tube for a transmission with four speeds.

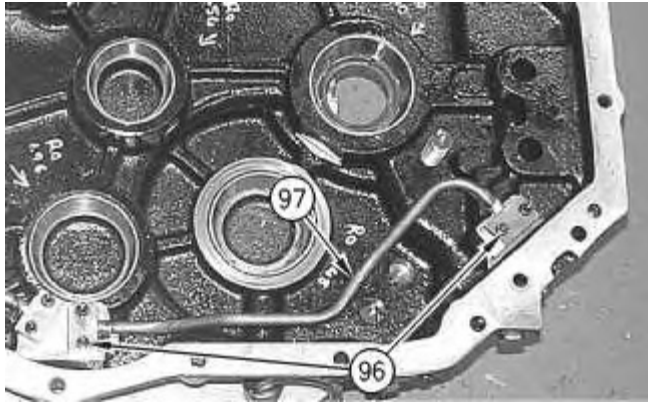

Illustration 46

g00895675

Cover of a Transmission with Four Speeds

- a. Remove four allen head screws (96) in order to remove oil tube (97) .

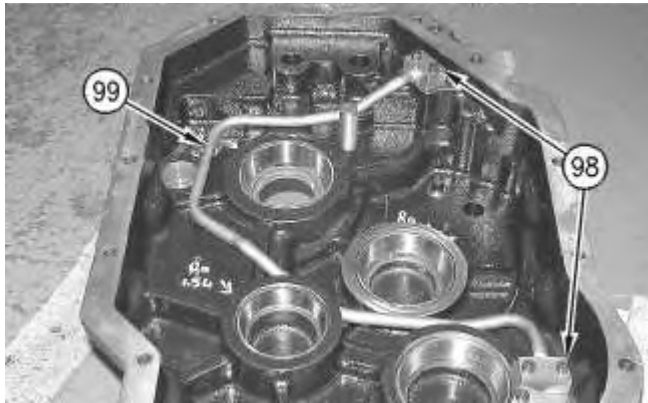

Illustration 47

g00895659

Cover of a Transmission with Five Speeds

- b. Remove four allen head screws (98) in order to remove oil tube (99) .

Note: There is an O-ring seal at both ends of the oil tube. Inspect each seal and replace the seals, if necessary.

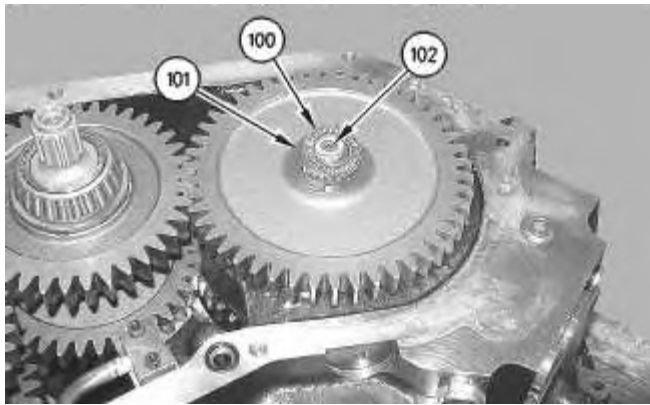

Illustration 48

g00893603

43. Remove thrust bearing (100) and sleeve (101) for the thrust bearing from the end of input shaft (102) .

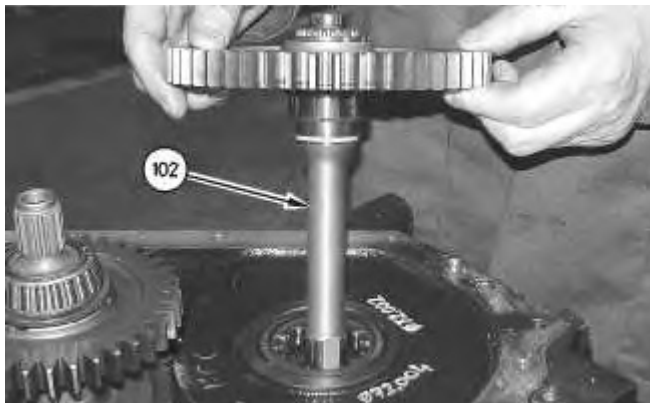

Illustration 49

g00893604

44. Remove input shaft (102) from the transmission.

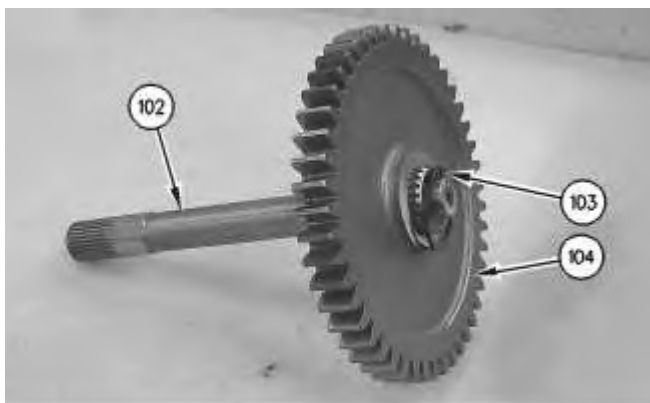

Illustration 50

g00893605

45. Use Tooling (I) in order to remove circlip (103), and remove gear (104) from input shaft (102) .

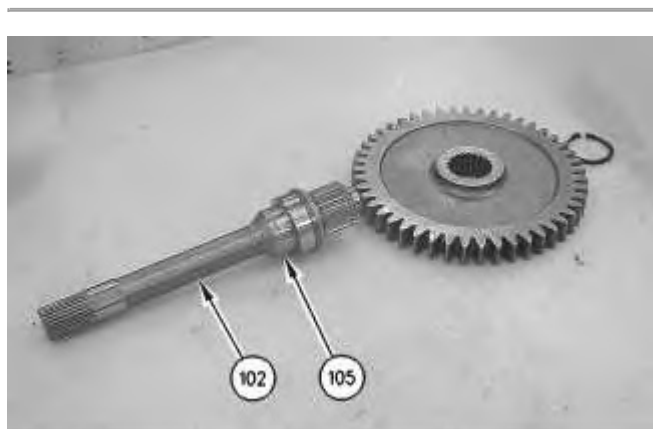

Illustration 51

g00893606

46. Remove split seal (105) from input shaft (102) and inspect the split seal for damage. Replace the split seal, if necessary.

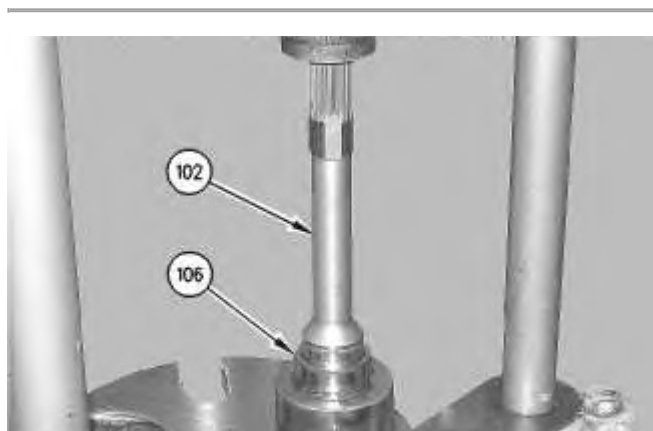

Illustration 52

g00893607

47. Use a suitable press in order to remove bearing carrier (106) from input shaft (102) .
-

Thank you so much for reading.
Please click the “Buy Now!”
button below to download the
complete manual.



After you pay.

You can download the most
perfect and complete manual in
the world immediately.

Our support email:

ebooklibonline@outlook.com