

Product: TELEHANDLER

Model: TH63 TELEHANDLER 3NN

Configuration: TH63 Telehandler 3NN00001-UP (MACHINE) POWERED BY 3054 Engine

## **Disassembly and Assembly 3054 Engine for Caterpillar Built Machines**

Media Number -SEN6241-13

Publication Date -01/08/2008

Date Updated -04/08/2008

i01054405

# **Valve Mechanism Cover - Remove and Install**

SMCS - 1107-010

## **Removal Procedure**

---

### **NOTICE**

**Keep all parts clean from contaminants.**

**Contaminants may cause rapid wear and shortened component life.**

---

---

### **NOTICE**

**Care must be taken to ensure that fluids are contained during performance of inspection, maintenance, testing, adjusting and repair of the product. Be prepared to collect the fluid with suitable containers before opening any compartment or disassembling any component containing fluids.**

**Refer to Special Publication, NENG2500, "Caterpillar Tools and Shop Products Guide" for tools and supplies suitable to collect and contain fluids on Caterpillar products.**

**Dispose of all fluids according to local regulations and mandates.**

---

**Note:** The engines are equipped with either an aluminum valve cover or with a composite valve cover. The aluminum valve cover has a seal that fits between the valve cover and the inlet

manifold. The composite valve cover has a seal that is permanently fixed to the side of the valve cover.

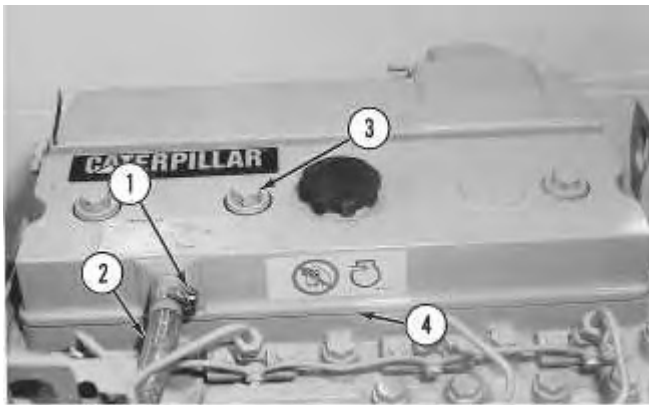

Illustration 1

g00547002

Typical example

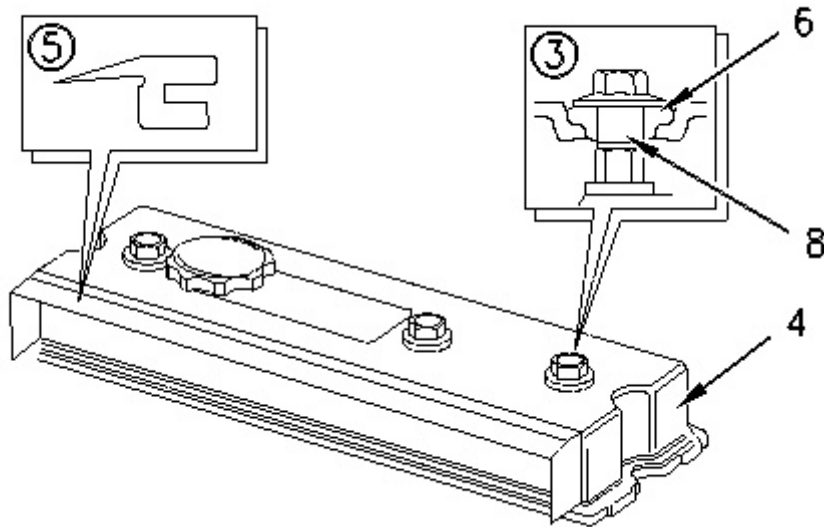
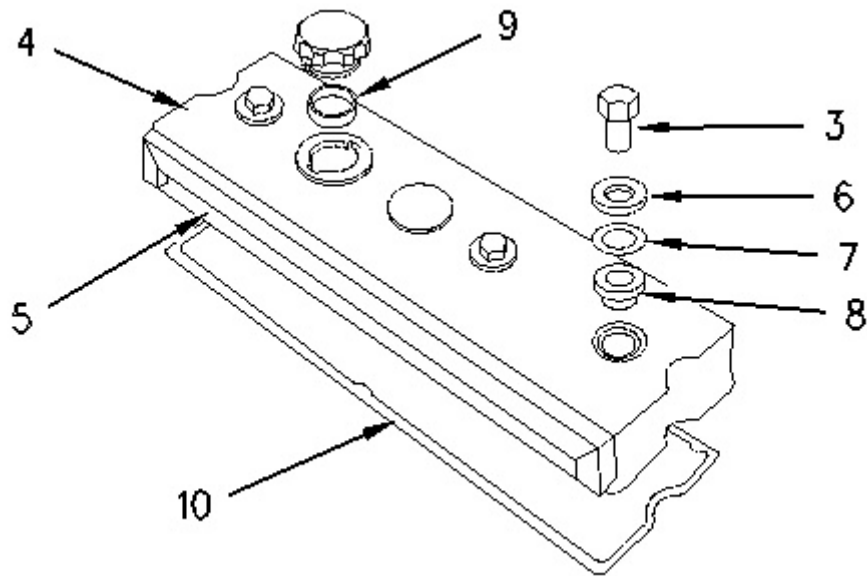

Illustration 2

g00547003

Aluminum valve cover

---



---

Illustration 3

g00547004

### Composite valve cover

1. Loosen hose clamp (1) .
2. Disconnect breather hose (2) .
3. Remove three nuts (3), steel washers (6), and sealing washers (8) .

**Note:** When you remove nuts (3), ensure that the nuts on the rocker arm bracket are not loosened.

**Note:** Current production engines have an additional shim washer (7) .

4. Remove valve cover (4), gasket (10), and seal (5) .
5. Remove seal (9) for the oil filler cap.

## Installation Procedure

**Note:** The engines are equipped with either an aluminum valve cover or with a composite valve cover. The aluminum valve cover has a seal that fits between the valve cover and the inlet manifold. The composite valve cover has a seal that is permanently fixed to the side of the valve cover.

---

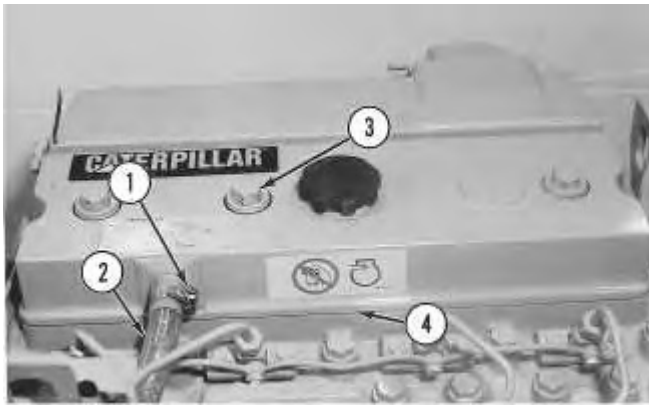

Illustration 4

g00547002

Typical example

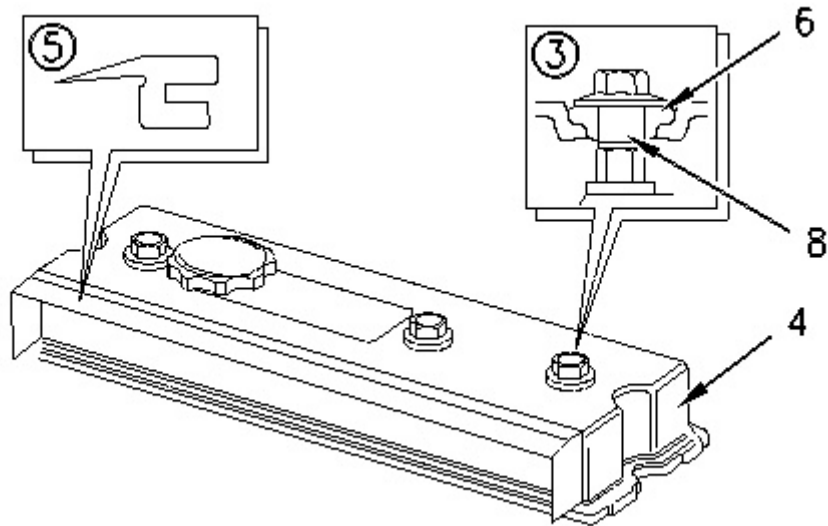

Illustration 5

g00547003

Aluminum valve cover

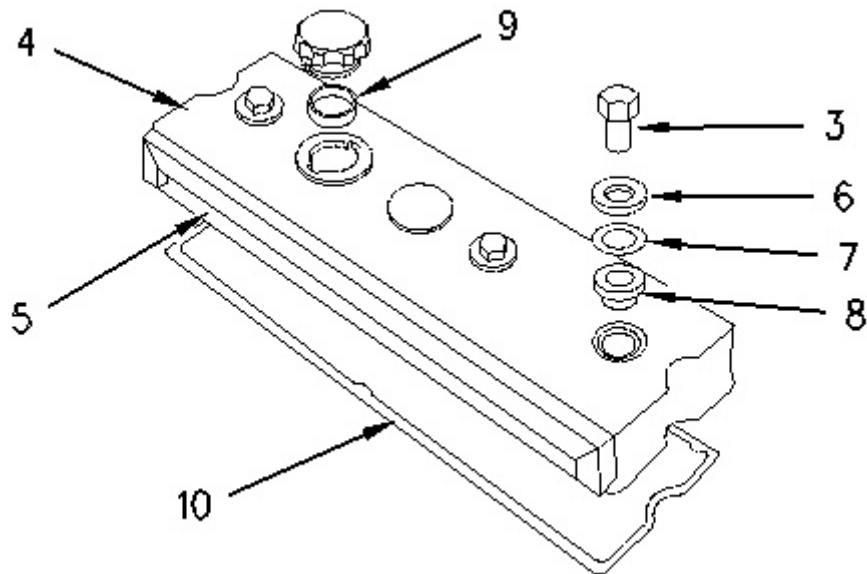

Illustration 6

g00547004

Composite valve cover

1. Inspect the condition of the gaskets and the seals. Replace the gaskets and the seals, if necessary.
2. Install seal (9) for the oil filler cap, if necessary.
3. Apply **8T-9022** Silicone Gasket to gasket (10) .

**Note:** Ensure that the flat face of the gasket is toward the valve cover.

4. Install gasket (10), seal (5), and valve cover (4) .
5. Lubricate three nuts (3) with clean engine oil.
6. Install three nuts (3), steel washers (6), and sealing washers (8) .

**Note:** When you install three nuts (3) without shim washers (7), tighten the nuts to a torque of 20 N·m (15 lb ft). Do not overtighten the nuts.

**Note:** When you install three nuts (3) with shim washers (7), tighten the nuts to a torque of 30 N·m (22 lb ft). Do not overtighten the nuts.

7. Connect breather hose (2) .
8. Tighten hose clamp (1) .

Product: TELEHANDLER

Model: TH63 TELEHANDLER 3NN

Configuration: TH63 Telehandler 3NN00001-UP (MACHINE) POWERED BY 3054 Engine

## Disassembly and Assembly 3054 Engine for Caterpillar Built Machines

Media Number -SEN6241-13

Publication Date -01/08/2008

Date Updated -04/08/2008

i01761173

# Rocker Shaft and Pushrod - Remove

SMCS - 1102-011; 1208-011

## Removal Procedure

### Start By:

- a. Remove the valve mechanism cover. Refer to Disassembly and Assembly, "Valve Mechanism Cover - Remove and Install".

---

### NOTICE

**Keep all parts clean from contaminants.**

**Contaminants may cause rapid wear and shortened component life.**

---



Illustration 1

g00635152

Typical example

**Note:** It is not necessary to remove the oil supply tube in order to remove the rocker shaft assembly and the pushrods.

1. Remove nuts (1) and bolt (2) from the rocker shaft assembly. Begin with the end brackets and move toward the center.
2. Remove rocker shaft assembly (3).
3. Remove the oil seal from the oil supply passage in the cylinder head.

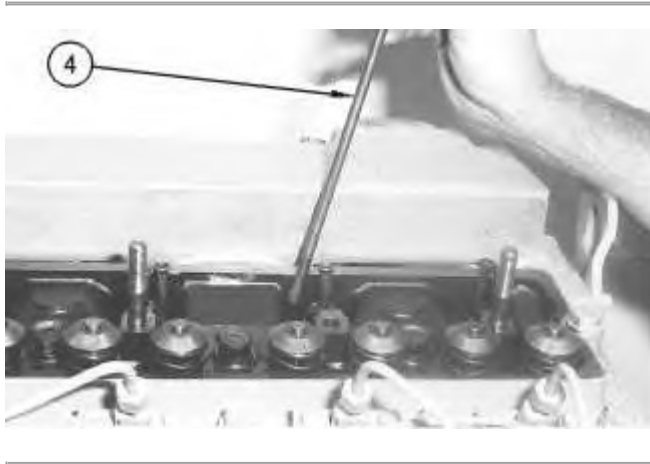

Illustration 2

g00635153

Typical example

4. Remove pushrods (4). Place an identification mark on the pushrods for installation.
-

Product: TELEHANDLER

Model: TH63 TELEHANDLER 3NN

Configuration: TH63 Telehandler 3NN00001-UP (MACHINE) POWERED BY 3054 Engine

## Disassembly and Assembly 3054 Engine for Caterpillar Built Machines

Media Number -SEN6241-13

Publication Date -01/08/2008

Date Updated -04/08/2008

i01667090

### Rocker Shaft - Disassemble

SMCS - 1102-015

### Disassembly Procedure

Table 1

Required Tools			
Tool	Part Number	Part Description	Qty
A	1P-0510	Driver Group	1

#### Start By:

- A. Remove the rocker shaft assembly. Refer to Disassembly and Assembly, "Rocker Shaft and Pushrod - Remove".



Illustration 1

g00550061



1. Use a screwdriver or a similar tool to remove retaining ring (1) from both ends of the rocker shaft assembly.

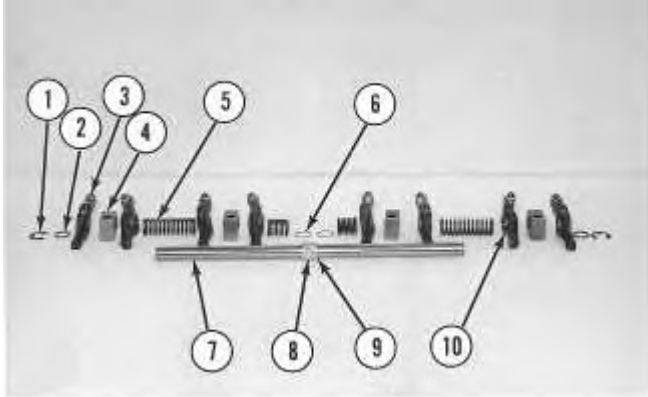

Illustration 2

g00550062

- (1) Retaining ring
  - (2) Washer on the end of the rocker shaft
  - (3) Rocker arm assembly
  - (4) Rocker shaft bracket
  - (5) Spring on the rocker shaft
  - (6) Washer
  - (7) Rocker shaft
  - (8) Bolt
  - (9) Oil supply connection
  - (10) Rocker arm bushing
2. Remove the rocker arms and the rocker shaft brackets from the rocker shaft assembly.  
**Note:** Place an identification mark on each of the components for the proper order for installation.
  3. Check the clearance between rocker arm assembly (3) and rocker shaft (7). Replace rocker arm bushing (10) if the clearance is larger than 0.13 mm (0.005 inch). Use Tool (A) and a suitable press in order to remove rocker arm bushing (10) from rocker arm assembly (3), if necessary.
  4. Remove rocker shaft bracket (4) from rocker shaft (7) .
  5. Remove springs (5), washer (6), bolt (8) and oil supply connection (9) from rocker shaft (7) .

Product: TELEHANDLER

Model: TH63 TELEHANDLER 3NN

Configuration: TH63 Telehandler 3NN00001-UP (MACHINE) POWERED BY 3054 Engine

## Disassembly and Assembly 3054 Engine for Caterpillar Built Machines

Media Number -SEN6241-13

Publication Date -01/08/2008

Date Updated -04/08/2008

i01667093

### Rocker Shaft - Assemble

SMCS - 1102-016

### Assembly Procedure

1. Lubricate all of the components with clean engine oil.

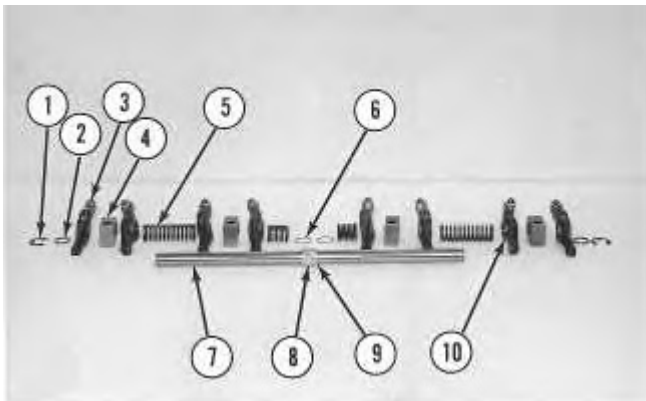

Illustration 1

g00550062

- (1) Retaining ring
- (2) Washer on the end of the rocker shaft
- (3) Rocker arm assembly
- (4) Rocker shaft bracket
- (5) Spring on the rocker shaft
- (6) Washer
- (7) Rocker shaft

- (8) Bolt
- (9) Oil supply connection
- (10) Rocker arm bushing

2. Install oil supply connection (9) and bolt (8) on rocker shaft (7) .

**Note:** Ensure that the bolt and the connection are correctly positioned on the rocker shaft.

**Note:** Ensure that all of the oil holes in the rocker shaft and in the rocker arms are not plugged before you begin the assembly procedure.

3. Install rocker arm bushing (10) in rocker arm assembly (3) with a suitable press. Ream the bushing to a clearance of  $0.06 \pm 0.03$  mm ( $0.0024 \pm 0.0012$  inch), if necessary.
4. Install each of the components in the correct order onto rocker shaft (7). See Illustration 1.

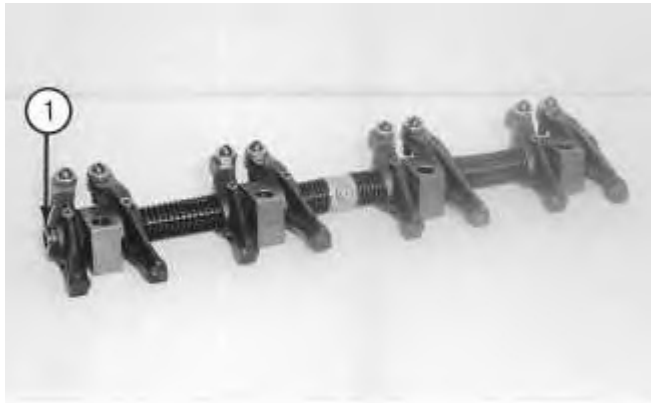

---

Illustration 2

g00550061

5. Install retaining ring (1).

**End By:** Install the rocker shaft assembly. Refer to Disassembly and Assembly, "Rocker Shaft and Pushrod - Install".

---

Product: TELEHANDLER

Model: TH63 TELEHANDLER 3NN

Configuration: TH63 Telehandler 3NN00001-UP (MACHINE) POWERED BY 3054 Engine

## Disassembly and Assembly 3054 Engine for Caterpillar Built Machines

Media Number -SEN6241-13

Publication Date -01/08/2008

Date Updated -04/08/2008

i01749382

# Rocker Shaft and Pushrod - Install

SMCS - 1102-012; 1208-012

## Installation Procedure

---

### NOTICE

**Keep all parts clean from contaminants.**

**Contaminants may cause rapid wear and shortened component life.**

---



Illustration 1

g00635153

Typical example

1. Install pushrods (4).

**Note:** Ensure that the pushrods are installed in the original location and that the pushrods are seated in the valve lifters correctly.

2. Install a new oil seal in the oil supply hole in the cylinder head.

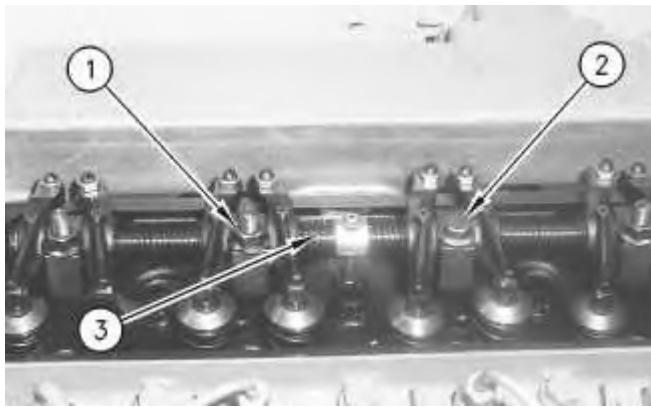

Illustration 2

g00635152

Typical example

3. Put rocker shaft assembly (3) in position on the cylinder head. Make sure that the connection for the oil supply is installed correctly into the oil seal.

**Note:** Ensure that the adjustment screws are properly seated in the ends of pushrods (4).

**Note:** It may be necessary to loosen the adjustment screws on each rocker arm. This will help prevent a bent valve or a bent pushrod during the installation of the rocker shaft.

4. Lubricate nuts (1) and bolt (2) with clean engine oil.
5. Install nuts (1) and bolt (2).
6. Alternately tighten the nuts and the bolt. Start from the center and work toward the outside. Tighten the nuts and the bolt on an aluminum bracket to a torque of 40 N·m (30 lb ft). Tighten the nuts and the bolt on a cast iron or a steel bracket to a torque of 75 N·m (55 lb ft).
7. Adjust the inlet valve lash to 0.20 mm (0.008 inch) and adjust the exhaust valve lash to 0.45 mm (0.018 inch). Refer to Testing and Adjusting, "Air Inlet and Exhaust System" for more information on adjusting the valve lash.

**End By:**

- a. Install the valve mechanism cover. Refer to Disassembly and Assembly, "Valve Mechanism Cover - Remove and Install".
-

Product: TELEHANDLER

Model: TH63 TELEHANDLER 3NN

Configuration: TH63 Telehandler 3NN00001-UP (MACHINE) POWERED BY 3054 Engine

## **Disassembly and Assembly 3054 Engine for Caterpillar Built Machines**

Media Number -SEN6241-13

Publication Date -01/08/2008

Date Updated -04/08/2008

i01645897

# **Cylinder Head - Remove**

SMCS - 1100-011

## **Removal Procedure**

### **Start By:**

- A. Disconnect the electrical connections at the battery.
  - B. Drain the coolant system. If the engine uses Diesel Engine Antifreeze/Coolant (DEAC), refer to Operation and Maintenance Manual, "Cooling System Coolant (DEAC) - Change". If the engine uses Extended Life Coolant (ELC), refer to Operation and Maintenance Manual, "Cooling System Coolant (ELC) - Change".
  - C. Remove the air inlet manifold. Refer to Disassembly and Assembly, "Air Inlet Manifold - Remove".
  - D. Remove the exhaust manifold. Refer to Disassembly and Assembly, "Exhaust Manifold - Remove and Install".
  - E. Remove the fuel injection nozzles. Refer to Disassembly and Assembly, "Fuel Injection Nozzles - Remove".
  - F. Remove the fuel filter base. Refer to Disassembly and Assembly, "Fuel Filter Base - Remove and Install".
  - G. Remove the water outlet manifold. Refer to Disassembly and Assembly, "Water Outlet Manifold - Remove".
  - H. Remove the rocker shaft assembly and the pushrods. Refer to Disassembly and Assembly, "Rocker Arm and Shaft - Remove".
-

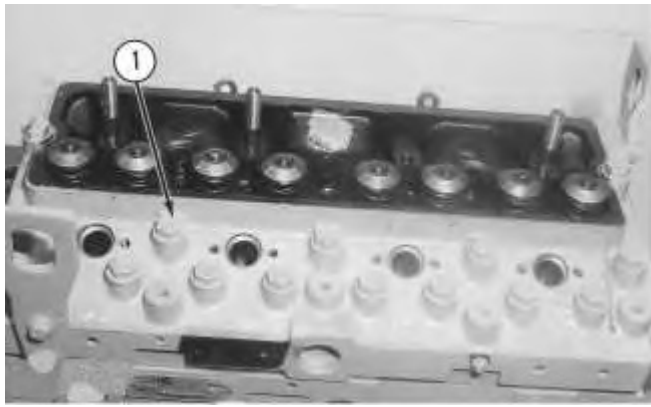

Illustration 1

g00550160

Typical example

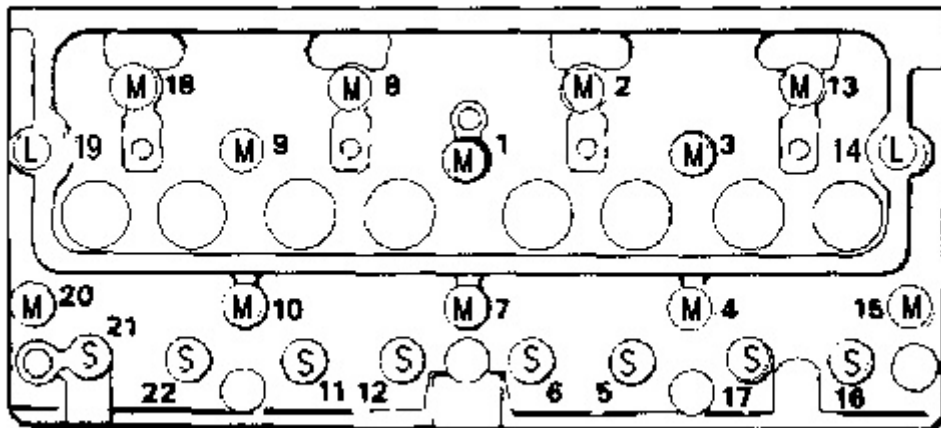

Illustration 2

g00550162

1. Gradually loosen 22 cylinder head bolts (1) in the reverse order that is shown in Illustration 2. This will help prevent distortion of the cylinder head.

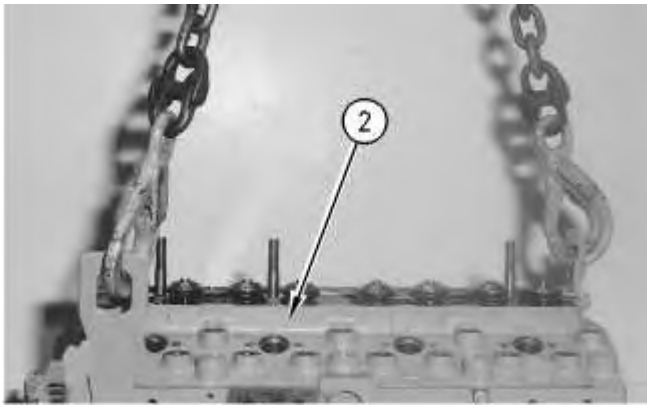

Illustration 3

g00550163

Typical example

2. Attach a suitable lifting device to cylinder head (2). Carefully lift cylinder head (2) off the engine block. The weight of the cylinder head is 41 kg (90 lb).

---

### NOTICE

**Place the cylinder head on a surface that will not scratch the face of the cylinder head.**

---

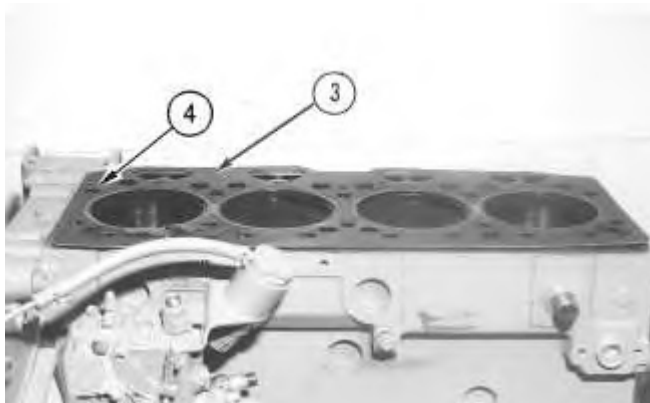
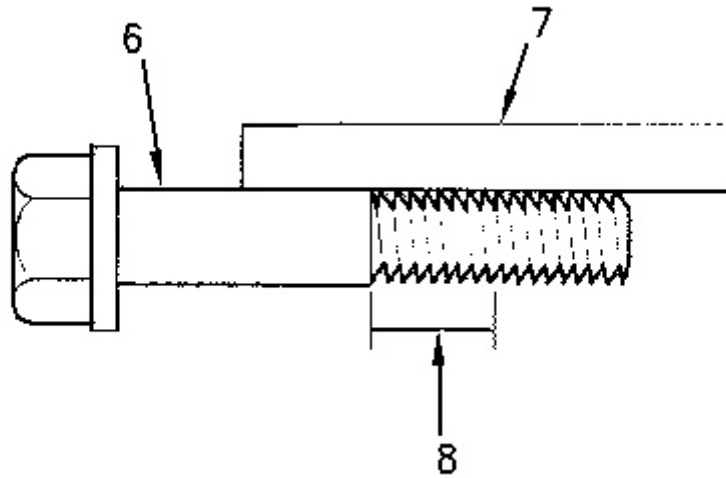

Illustration 4

g00550165

3. Remove cylinder head gasket (3) .
  4. Note the location of dowels (4) on each end of the cylinder block. Dowels (4) hold cylinder head gasket (3) in place while cylinder head (2) is installed.
-





---

Illustration 5

g00741112

5. Align straight edge (7) with bolt (6) in order to check for distortion. If there is a visible reduction in the diameter of thread (8) that has not been in engagement with the cylinder block, the bolts must be replaced.
-

Product: TELEHANDLER

Model: TH63 TELEHANDLER 3NN

Configuration: TH63 Telehandler 3NN00001-UP (MACHINE) POWERED BY 3054 Engine

## Disassembly and Assembly 3054 Engine for Caterpillar Built Machines

Media Number -SEN6241-13

Publication Date -01/08/2008

Date Updated -04/08/2008

i01645901

# Cylinder Head - Install

SMCS - 1100-012

## Installation Procedure

Table 1

Required Tools			
Tool	Part Number	Part Description	Qty
A	9U-6238	Guide Bolt	2
B	8T-3052	Degree Wheel	1

1. Thoroughly clean the top of the cylinder block and the bottom of the cylinder head. Ensure that there is no debris in the cylinder bores.

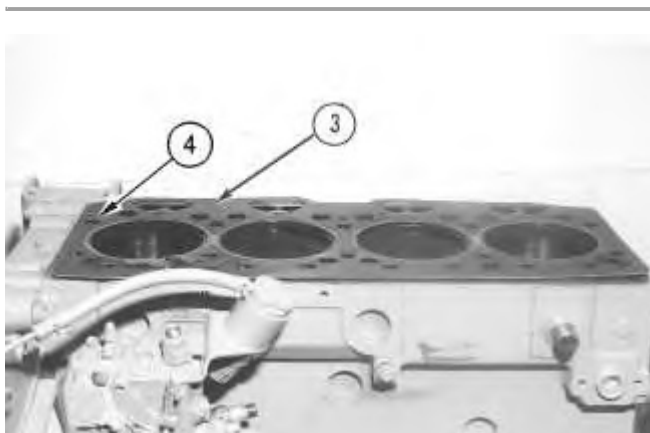
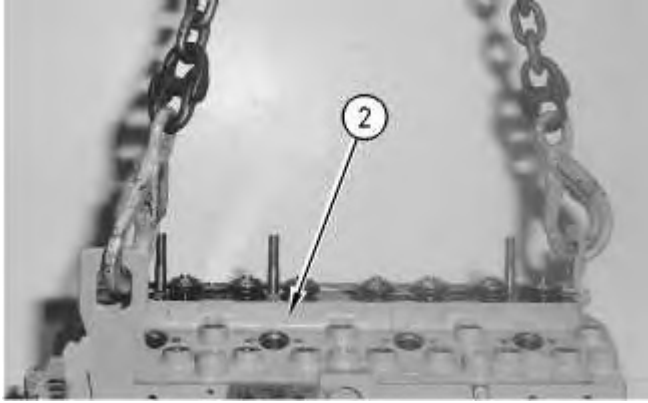

Illustration 1

g00550165

2. Place cylinder head gasket (3) on dowels (4) on top of the cylinder block. The cylinder head gasket (3) is stamped "FRONT TOP". Do not use any sealant or compound on the cylinder head gasket.
3. Install Tool (A) in positions 15 and 20 in the cylinder block. Refer to Illustration 4.



---

Illustration 2

g00550163

Typical example

4. Attach a suitable lifting device to cylinder head (2) .
5. Place cylinder head (2) on the cylinder block. Ensure that the cylinder head is positioned on dowels (4) and that cylinder head gasket (3) is positioned correctly.
6. Remove Tool (A) .

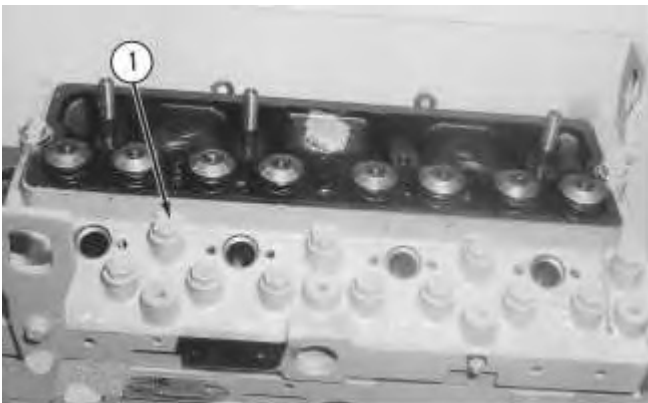

---

Illustration 3

g00550160

Typical example

7. Lubricate cylinder head bolts (1) with clean engine oil.

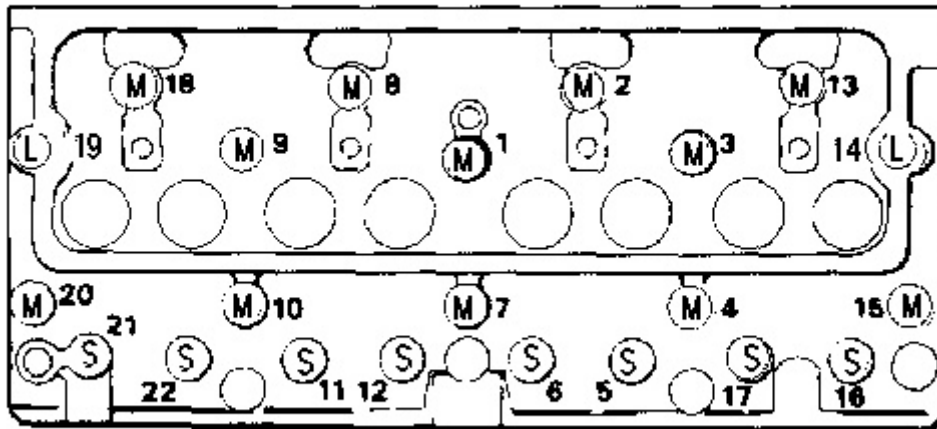

---

Illustration 4

g00550162

8. Gradually tighten all of the bolts (1 through 22) in a numerical sequence to a torque of 110 N·m (80 lb ft).
9. Tighten all of the bolts (1 through 22) again in a numerical sequence to a torque of 110 N·m (80 lb ft).
10. Place an index mark on the bolts and use Tool (B) in order to further tighten the bolts. Refer to illustration 4.
  - a. Turn the short bolts that are marked with an "S" for an additional 150 degrees (2.5 flats).
  - b. Turn the medium length bolts that are marked with an "M" for an additional 180 degrees (3.0 flats).
  - c. Turn the long bolts that are marked with an "L" for an additional 210 degrees (3.5 flats).

**End By:**

- a. Install the rocker shaft assembly. Refer to Disassembly and Assembly, "Rocker Arm and Shaft - Install".
- b. Install the water outlet manifold. Refer to Disassembly and Assembly, "Water Outlet Manifold - Install".
- c. Install the fuel filter base. Refer to Disassembly and Assembly, "Fuel Filter Base - Remove and Install".
- d. Install the fuel injection nozzles. Refer to Disassembly and Assembly, "Fuel Injection Nozzles - Install".
- e. Install the exhaust manifold. Refer to Disassembly and Assembly, "Exhaust Manifold - Remove and Install".
- f. Install the inlet manifold. Refer to Disassembly and Assembly, "Air inlet Manifold -Install".

- g. Fill the coolant system. If the engine uses Extended Life Coolant (ELC), refer to Operation and Maintenance Manual, "Cooling System Coolant (ELC) - Change". If the engine uses Diesel Engine Antifreeze/Coolant (DEAC), refer to Operation and Maintenance Manual, "Cooling System Coolant (DEAC) - Change".
  - h. Connect the electrical connections at the battery.
-

Thank you so much for reading.  
Please click the “Buy Now!”  
button below to download the  
complete manual.



After you pay.

You can download the most  
perfect and complete manual in  
the world immediately.

Our support email:

[ebooklibonline@outlook.com](mailto:ebooklibonline@outlook.com)