

Document Title: Track tension hydraulic system, description	Function Group: 770	Information Type: Service Information	Date: 2015/11/5
Profile: PAT, PF4410 [GB]			

Track tension hydraulic system, description

Track tension hydraulic system description

The track tension hydraulic system provides hydraulic pressure to keep the tracks secure on the track bogies. This prevents the tracks from slipping and provide proper traction to paver. The track tension circuit consist of the general purpose pump, two (2) track tension valve blocks and two (2) hydraulic cylinders.

Component location and functional diagram

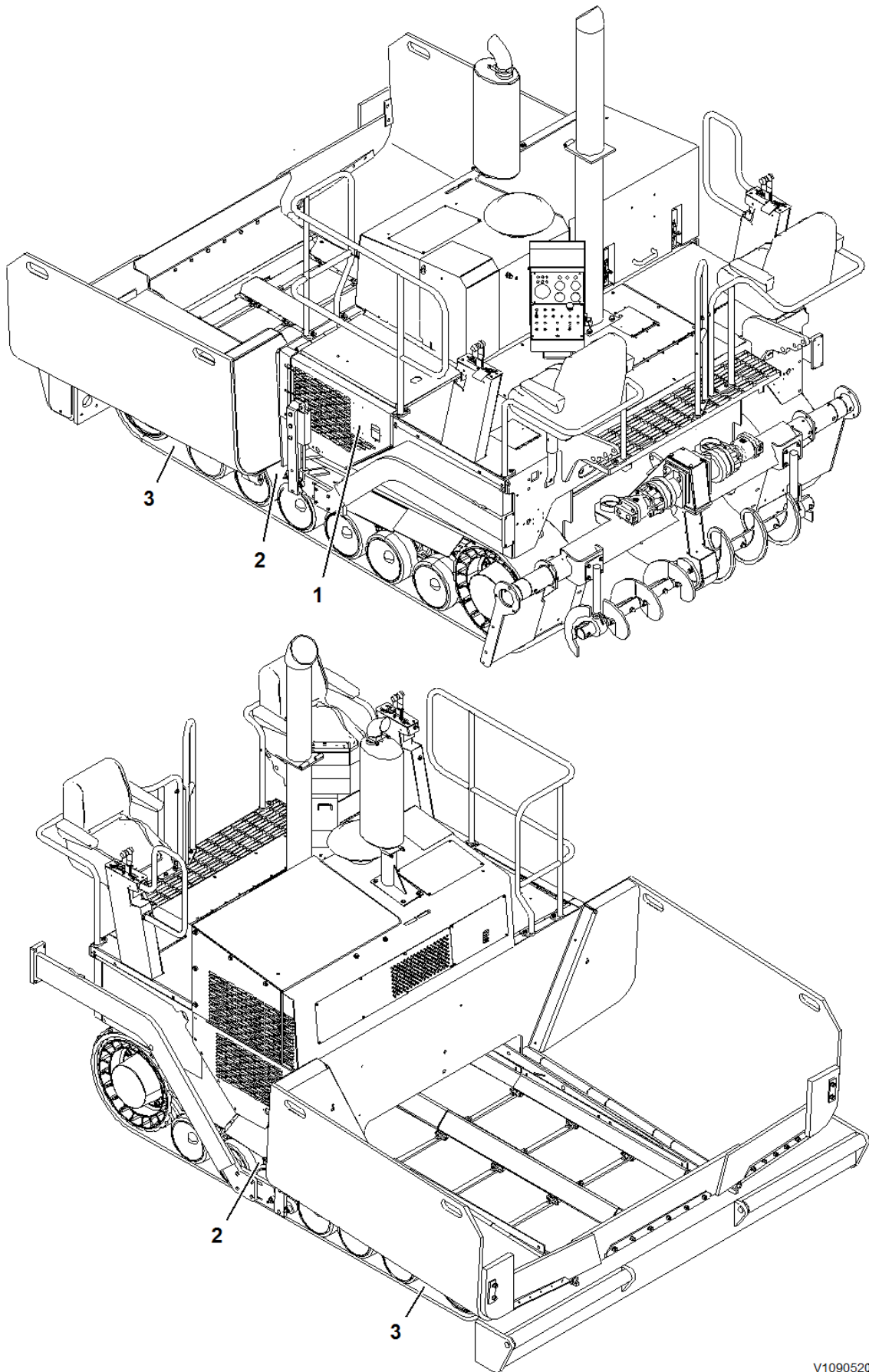

V1090520

Figure 1
Track tension system, component location

1. General purpose pump
2. Track tension valve
3. Track tension cylinder

Track tension hydraulic system description

The track tension hydraulic system is an open loop hydraulic circuit controlled by a fixed displacement piston pump. The general purpose pump supplies oil flow to the track tension circuit.

The oil from the general purpose pump then enters the two (2) track tension valve blocks. The track tension valve blocks consist of a check valve and a pressure relief valve. The oil from the general purpose pump enters the track tension valve block through the check valve. The oil then diverts into the piston end of the track tension cylinder. The oil from the rod end of the cylinder is sent to the relief valve and once the pressure on the relief valve is higher than the relief pressure setting, oil is diverted directly back to the tank. The pressure setting on the relief valve is what maintains a constant pressure on the tracks.

Summary

Track tension hydraulic system function depends on:

- Engine running
- Proper setting on the relief valve

Complementary information

Hydraulic diagram, refer to [910 Hydraulic diagram 1](#)

General purpose hydraulic system description, refer to [910 General purpose hydraulic system description](#)

Function checks

General purpose hydraulic system pressure check, refer to [912 General purpose hydraulic system pressure checking](#)

Relief setting on track tension valve block, refer to [7751 Track tension system relief pressure checking](#)

Document Title: Track tension system relief pressure, checking	Function Group:	Information Type: Service Information	Date: 2015/11/5
Profile: PAT, PF4410 [GB]			

Track tension system relief pressure, checking

Op nbr 775-089

This operation also includes required tools and times for applicable parts of the following operations:

- [191 Service position](#)
1. Place machine in the service position. Refer to [191 Service position](#).
 2. Relieve the tension of the track tension cylinder.
 - a. Place a length of rubber hose on the bleeder screw located on the track tension cylinder.
 - b. Place the opposite end of the hose in a suitable container.
 - c. Turn the bleeder screw counter clockwise until hydraulic oil drains into the container.
 - d. When the track tension cylinder retracts, close the bleeder screw by turning it clockwise until the hydraulic fluid stops flowing.

NOTE!

It is not necessary to fully retract the track tension cylinder in this operation.

3. Connect an appropriate pressure gauge to the pressurized hose supplying the track tension cylinder.

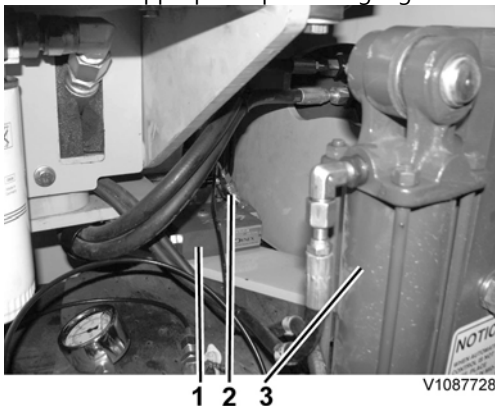

Figure 1

1. Valve
2. Nipple with attached pressure gauge
3. Tow point cylinder

NOTE!

The following step requires two (2) technicians.

4. One technician sits in the operator's seat and starts the engine. The second technician will place a block of wood between the track lugs behind the idler wheel. As the seated technician moves the appropriate FSR until the block is lodged between the track and the idler wheel, the second technician notes the pressure indicated on the pressure gauge.

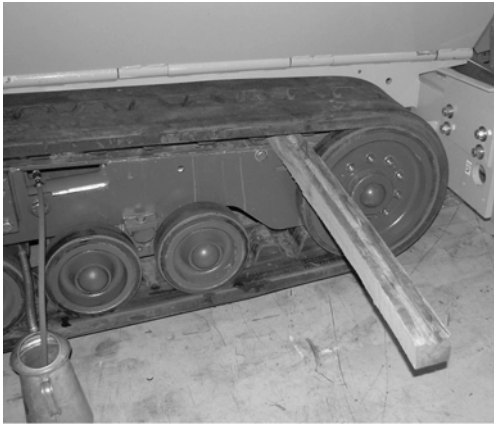

V1091151

Figure 2

A block of wood placed between the lug and idler wheel

5. Shut down the engine and remove the block of wood from the track lugs.
6. Disconnect the pressure gauge.
7. Start the engine and check for leaks.

Document Title: Rubber track, removing	Function Group:	Information Type: Service Information	Date: 2015/11/5
Profile: PAT, PF4410 [GB]			

Rubber track, removing

Op nbr 775-041

This operation also includes required tools and times for applicable parts of the following operations:

- [982 Screed, removing](#)
- [191 Service position](#)

1. Remove the screed from the tractor, if equipped. Refer to [982 Screed, removing](#).
2. Place machine in the service position. Refer to [191 Service position](#)
3. Place the hopper wings in the up position and lock them into place with the hopper locks.
4. Lift the apron plate to the rear position, exposing the front lift points of the machine.

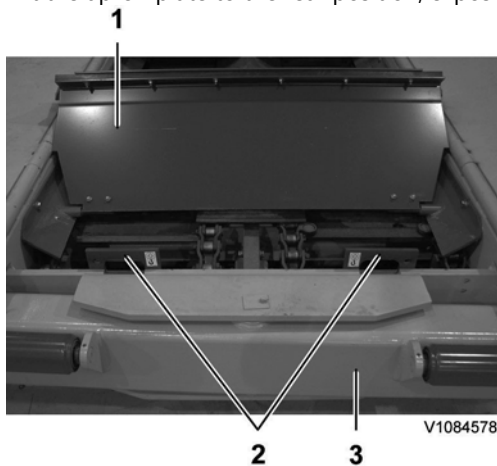

Figure 1

1. Apron plate
2. Lift points
3. Push roller



Risk of crushing injuries

5. Connect an appropriate lifting device to the front lift points, raising the machine and blocking as required to allow access to the take-up wheels.

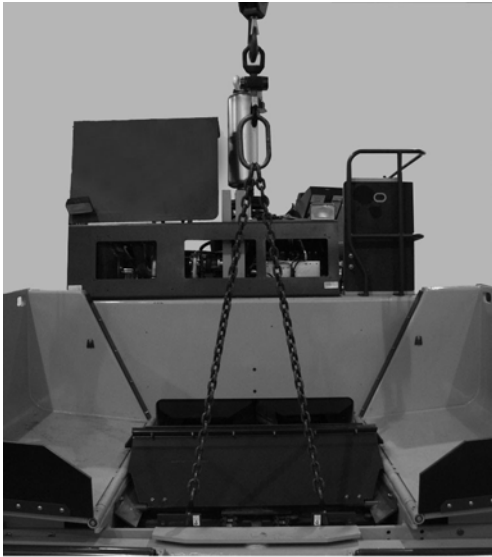

V1084579

Figure 2
Proper lifting procedure

NOTE!

Weight of the front end: 2903 kg (6400 lb)

6. Disconnect the lifting device from the front of the machine.
7. Connect an appropriate lifting device to the rear lift points, raising the machine and blocking to the same height determined in step 4.

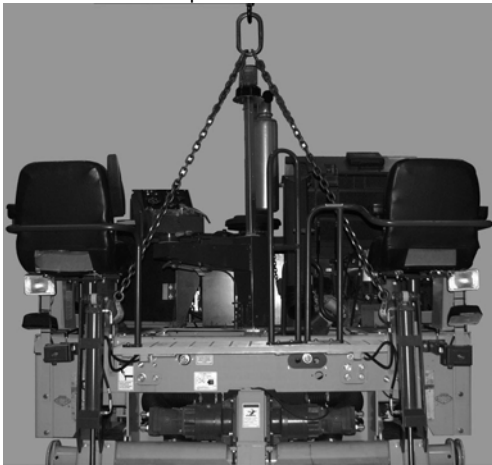

V1084580

Figure 3
Proper lifting procedure

8. Disconnect the lifting device from the rear of the machine.
9. Place one end of a length of rubber hose on the nipple of the bleeder screw of the track tension cylinder, with the other end in a suitable container placed on the ground.

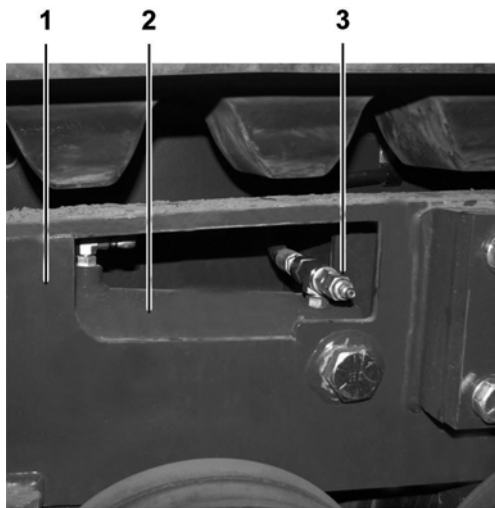

V1084581

Figure 4

1. Track frame
2. Track tension cylinder
3. Bleeder screw

10. Turn the bleeder screw in a counter clockwise direction until hydraulic oil starts flowing into the suitable container. Push the take up wheels toward the rear of the machine until they stop and tighten the bleeder screw on the track tension cylinder. Discard the hydraulic oil in accordance with local environmental guidelines.
11. Clean and label the tow point hoses.
12. Disconnect the tow point hoses. Plug or cap all open hose ends and ports.
13. Place an appropriate lifting device around the tow point.

NOTE!

Weight of the tow point: 52 kg (114 lb)

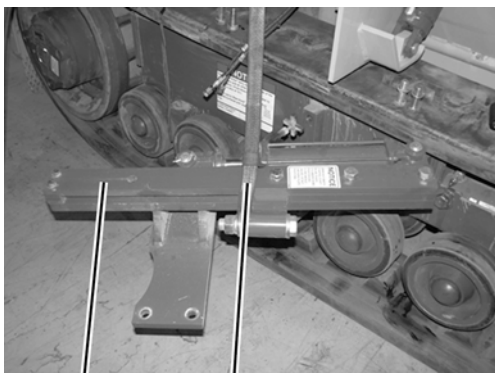

V1084831

Figure 5

1. Tow point
2. Lifting device

14. Remove the bolts and washers securing the tow point to the track frame and remove the tow point from the machine.
15. Place an appropriate lifting device through a hole on the drive wheel, securing the rubber track at the same time. Raise the lifting device to remove all slack.

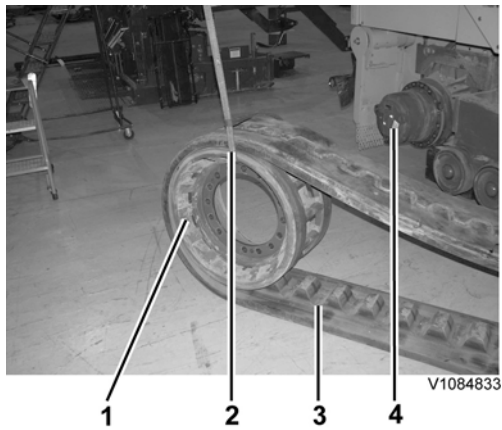

Figure 6

1. Drive wheel
2. Lifting device
3. Rubber track
4. Propulsion planetary

NOTE!

Weight of the drive wheel and track: 426 kg (940 lb)

16. Remove the hardware securing the drive wheel to the planetary.
17. Pull the drive wheel and rubber track off the machine as one piece, and place on the ground close to the machine.
18. Disconnect the lifting device from the drive wheel and track.
19. Install an eyebolt in one of the threaded holes on the outer take up wheel and attach an appropriate lifting device. Raise the lifting device to remove all slack.

NOTE!

Weight of take up wheel: 17 kg (38 lb)

20. Remove the hardware securing the outer take up wheel to the idler assembly. Using the lifting device, remove the take up wheel from the idler assembly and place the take up wheel on a suitable working surface. Disconnect the lifting device and eyebolt.
21. Attach an appropriate lifting device to the rubber track behind the idler assembly.

NOTE!

Weight of the rubber track: 211 kg (465 lb)

22. Using the lifting device, remove the rubber track from the machine.

Document Title: Rubber track, installing	Function Group:	Information Type: Service Information	Date: 2015/11/5
Profile: PAT, PF4410 [GB]			

Rubber track, installing

Op nbr 775-042

1. With an appropriate lifting device, lift the rubber track until the lugs on the track align with the middle of the idler assembly and disconnect the lifting device.



Figure 1

1. Idler assembly
2. Rubber track

NOTE!

Weight of the rubber track: 211 kg (465 lb)

NOTE!

It may be helpful to secure the rubber track to the track frame with a strap until the outer take up wheel is installed.

2. Install an eyebolt in one of the threaded holes on the outer take up wheel and attach an appropriate lifting device.

Figure 2
Threaded holes

NOTE!

Weight of take up wheel: 17 kg (38 lb)

3. Raise the take up wheel and align the holes in the wheel with the studs on the idler assembly, then push the take up wheel onto the studs.
4. Secure the outer take up wheel with two (2) flange nuts. Disconnect the lifting device and remove the eyebolt.
5. Apply a high strength thread locking compound and secure the take up wheel with the flange nuts. Tighten and torque. Refer to [030 Tightening torque, specifications](#).
6. Connect the lifting device through a hole on the drive wheel, securing the rubber track at the same time. Raise the lifting device to remove all slack.

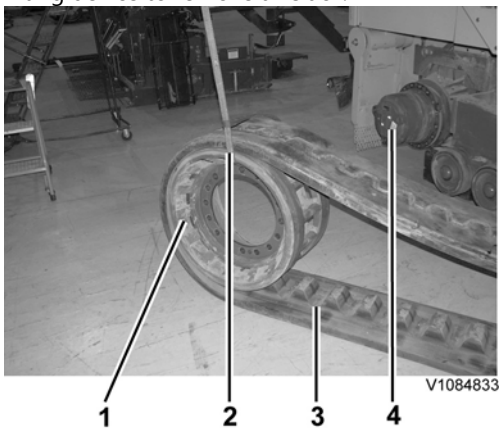

Figure 3

1. Drive wheel
2. Lifting device
3. Rubber track
4. Propulsion planetary

NOTE!

Weight of the drive wheel and track: 426 kg (940 lb)

7. Raise the drive wheel and align the holes in the drive wheel with the holes on the planetary. Secure the alignment by starting two bolts with washers into the holes. Remove the lifting device.

8. Apply a high strength thread locking compound and secure the drive wheel to the planetary with the bolts and washers. Tighten and torque. Refer to [030 Thread locking compound, application/specifications](#) and [030 Tightening torque, specifications](#).
9. Attach the tow point assembly to an appropriate lifting device.

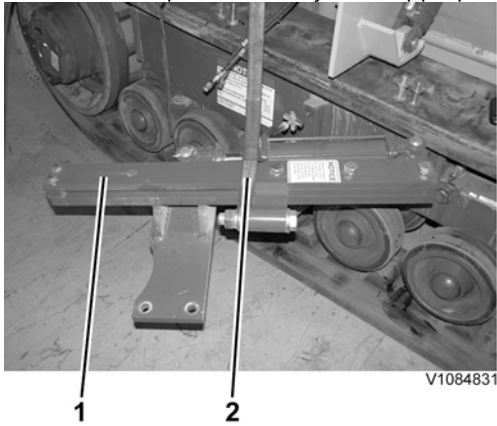

Figure 4

1. Tow point
2. Lifting device

NOTE!

Weight of the tow point: 52 kg (114 lb)

10. Raise the tow point assembly until the four holes in the tow point align with the four threaded holes in the track frame.
11. Apply a high strength thread locking compound to the hardware and secure the tow point assembly to the track frame. Tighten and torque. Refer to [030 Thread locking compound, application/specifications](#) and [030 Tightening torque, specifications](#).

NOTICE

It is very important to keep the hydraulic system free from any impurities, as these can cause abnormal wear and may lead to expensive downtime. Greatest possible cleanliness should be maintained during all handling of hydraulic components and hydraulic oil.

12. Clean, uncap and connect the hoses to the tow point cylinder. Tighten and torque. Refer to [030 Hydraulic connections, tightening torques](#).

! WARNING

Risk of crushing injuries

13. Connect an appropriate lifting device to the rear lift points, raising the machine and removing the blocks.

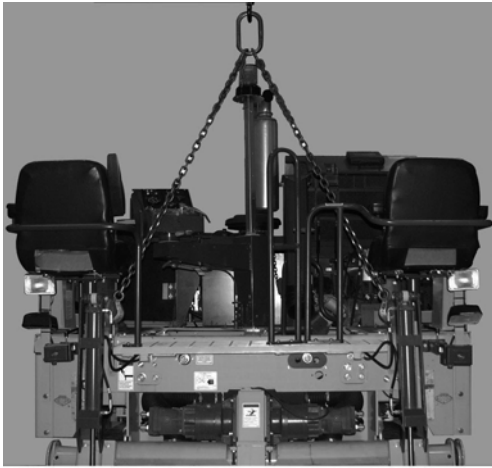

V1084580

Figure 5
Proper lifting procedure

14. Disconnect the lifting device from the rear of the machine.
15. Connect an appropriate lifting device to the front lift points, raising the machine and removing the blocks.

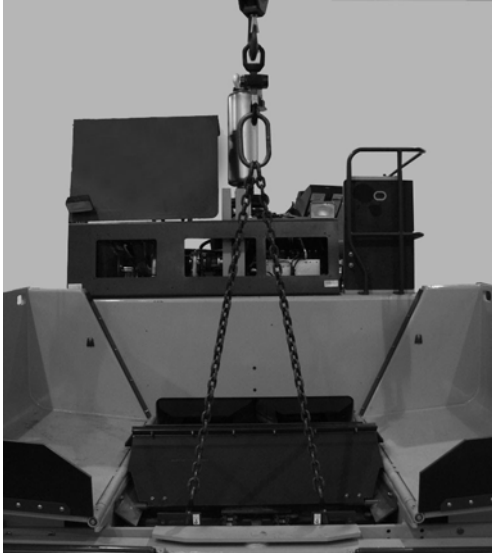

V1084579

Figure 6
Proper lifting procedure

NOTE!

Weight of the front end: 2903 kg (6400 lb)

16. Disconnect the lifting device from the front of the machine.
17. Move the apron plate to the forward operating position.

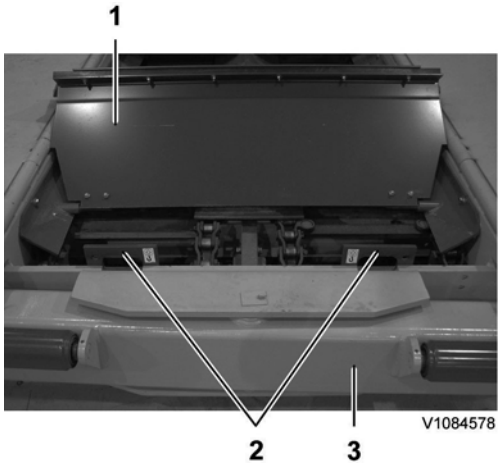

Figure 7

1. Apron plate
2. Lift points
3. Push roller

18. Start the engine and check for leaks and function.

Thank you so much for reading.
Please click the “Buy Now!”
button below to download the
complete manual.



After you pay.

You can download the most
perfect and complete manual in
the world immediately.

Our support email:

ebooklibonline@outlook.com