

WORKSHOP MANUAL

For Models

ERP/C16-20ATF

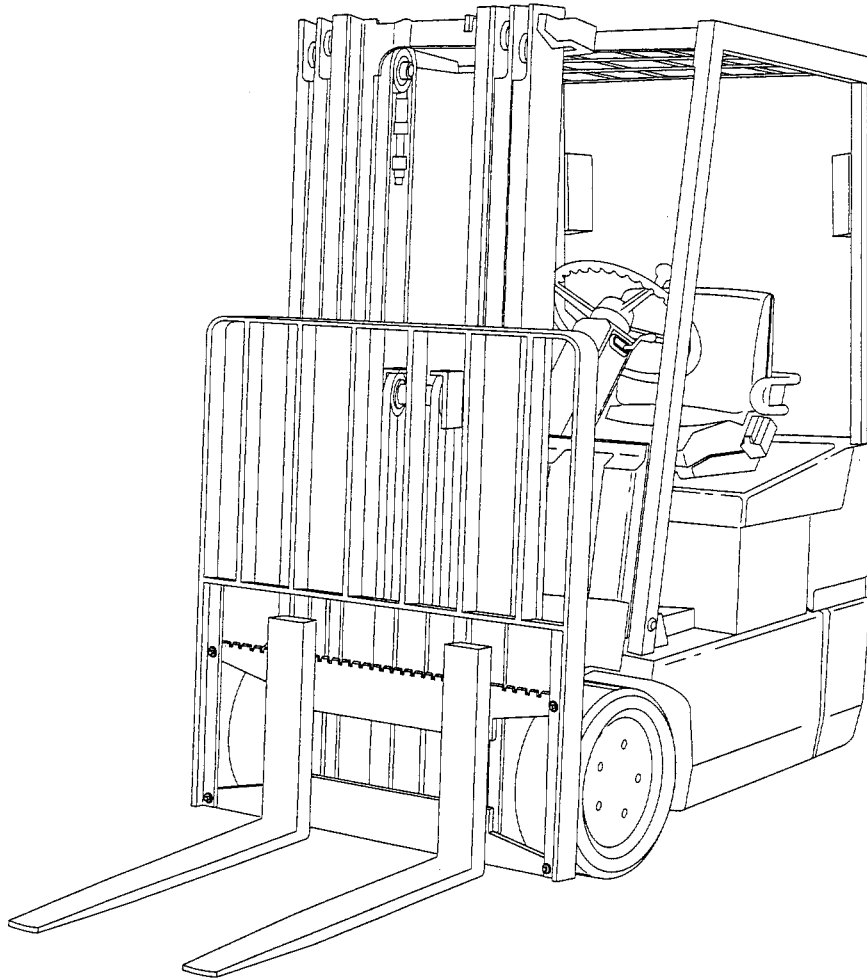

*Copies of this and other publications for this range of lift trucks are available.
For details contact Your Local Dealer.*

Yale Europe Materials Handling Limited

St. David's Court
Union Street
Wolverhampton
ENGLAND WV1 3JE
Telephone: (01902) 875500
Telex: 333642
Telefax: (01902) 875566

For Service & Parts-Contact

Authorized Dealer

EXPLANATION OF TRUCK MODEL CODE

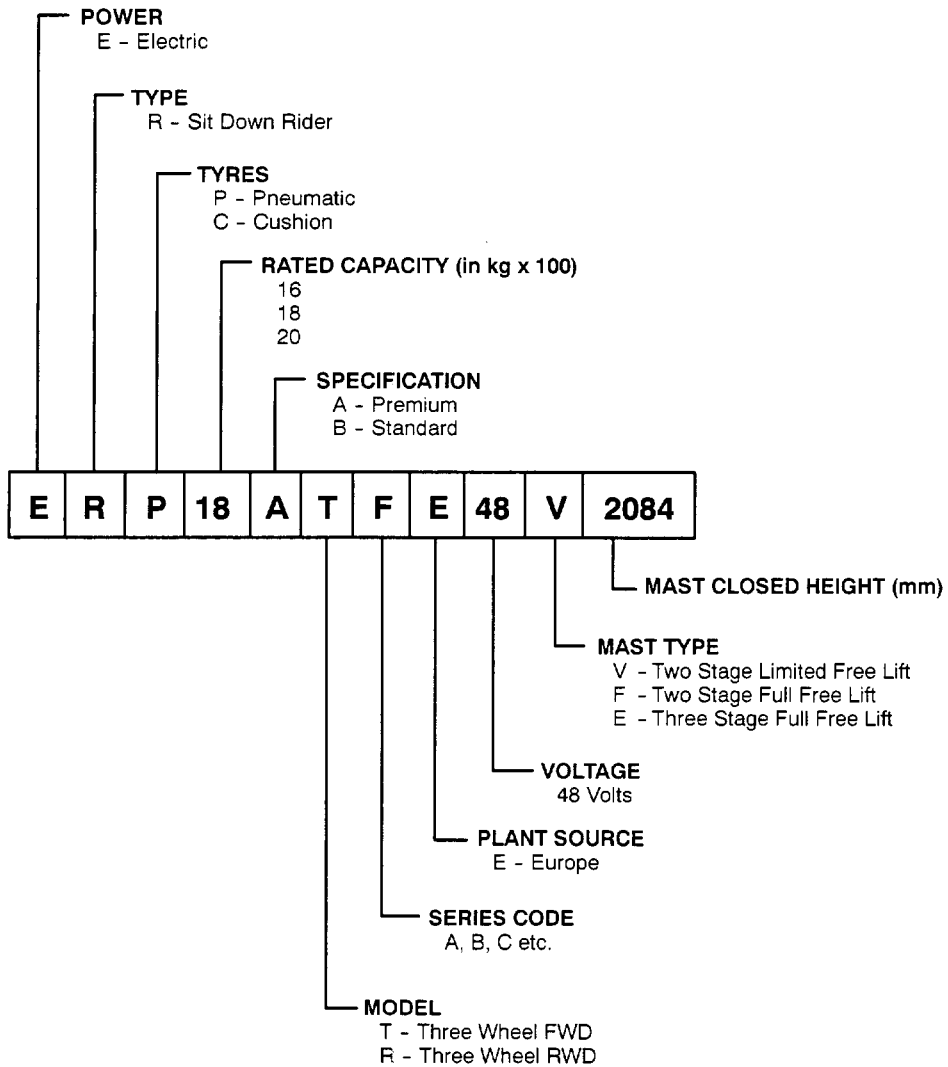

This Maintenance Manual is divided into major sections which are listed on this page. Quick reference to these sections can be made by placing the right thumb on the tab of the desired section, bending the book back and thumbing the pages to the corresponding tab.

SECTIONS

| | |
|-----------|---------------------------------------|
| 1 | OPERATING INSTRUCTIONS |
| 2 | GENERAL TRUCK AND LUBRICATION |
| 3 | ELECTRICAL SYSTEM |
| 4 | DRIVE UNIT |
| 5 | BRAKE SYSTEM |
| 6 | TRAIL AXLE AND STEERING SYSTEM |
| 7 | HYDRAULIC SYSTEM |
| 8 | MAST |
| 9 | BATTERY AND CHARGING SYSTEM |
| 10 | USER SUPPORT INFORMATION |
| 11 | ALPHABETICAL INDEX |

SAFETY PRECAUTIONS MAINTENANCE AND REPAIR

- When lifting parts or assemblies, make sure that all slings, chains, or cables are correctly fastened and that the load being lifted is balanced. Make sure that the crane, cables, and chains have the capacity to support the weight of the load.
- Do not lift heavy parts by hand. Use a lifting mechanism.
- Wear safety glasses.
- **DISCONNECT THE BATTERY CONNECTOR** before doing any maintenance or repair on electric lift trucks.
- Always use correct blocks to prevent the unit from rolling or falling. See "How to Put the Lift Truck on Blocks" in the **OPERATOR'S MANUAL** or **SECTION 2, GENERAL TRUCK AND LUBRICATION**.
- Keep the unit and working area clean and in order.
- Use the correct tools for the job.
- Keep the tools clean and in good condition.
- Always use **YALE APPROVED** parts when making repairs. Replacement parts must meet or exceed the specifications of the original equipment manufacturer.
- Make sure that all nuts, bolts, circlips, and other fastening devices are removed before using force to remove parts.
- Always fasten a **DO NOT OPERATE** sign to the controls of the unit when making repairs or if the unit needs repairs.
- Make sure you follow the **DANGER, WARNING, and CAUTION** notes in the instructions.
- Wear a rubber apron, gloves, boots, and goggles or a face shield when doing maintenance on batteries.
- Batteries generate hydrogen gas when they are being charged. Keep open fire away from batteries. Do not check the electrolyte level with a match or a lighter. No smoking and do not create sparks. Make sure the area has ventilation. If the battery is charged in the lift truck, open the bonnet.
- Lift batteries correctly with a crane or equipment designed for the job. Always use a spreader bar designed and adjusted for the battery. Move batteries with a lift truck, or a conveyor or rollers designed for that purpose. If the battery does not have a cover, a rubber mat or insulating material must be put over the top of the battery to prevent a short circuit with other equipment. Make sure the lifting equipment has enough capacity for the job. Do not use chain or wire rope slings.
- Never put metal materials or tools on a battery.
- When maintenance on the battery or the battery charger is required, disconnect both the AC and DC power. If new battery connectors must be installed, make sure the positive and negative terminals and cables are kept separate and insulated from each other. Even a momentary short circuit can cause an explosion and damage the battery.
- Keep water readily available to flush spilled electrolyte. Electrolyte in the eyes must be flushed with water immediately and then quickly get medical attention. Special showers and eye wash systems are required in areas where battery maintenance is done.
- If electrolyte is spilled on a work surface or the floor, flush the area with water, use a solution of soda (sodium bicarbonate) to make the acid neutral.
- Only trained persons are permitted to do maintenance on batteries and battery chargers. Make sure that the regulations by government safety agencies, government insurers, private insurers, and private organizations are followed when doing maintenance on batteries.

NOTE: The following symbols and words indicate safety information in this manual:



DANGER: Indicates a condition that will cause immediate death or injury!



WARNING: Indicates a condition that can cause death or injury!



CAUTION: Indicates a condition that can cause property damage!

CONTENTS

| Section 1 | Section 2 |
|--|---|
| GENERAL 1-1 | HYDRAULIC TANK 2-5 |
| SAFETY AND INFORMATIONAL LABELS 1-2 | Inspection 2-5 |
| OPERATOR PRECAUTIONS 1-2 | Repairs, Small Leaks 2-5 |
| OPERATOR PRE-CHECKS AND INSPECTION 1-3 | Repairs, Large Leaks 2-5 |
| OPERATING PROCEDURE 1-3 | Cleaning 2-5 |
| SHUT DOWN PROCEDURE 1-4 | Steam Method of Cleaning 2-6 |
| FORK ADJUSTMENT 1-4 | Chemical Solution Method of Cleaning 2-6 |
| SAFETY AND OPERATIONAL CHECK LIST 1-5 | Additional Preparations for Repair 2-6 |
| MODEL AND CONTROL INFORMATION 1-7 | WELDING REPAIRS 2-6 |
| Instrument Panel A (STANDARD) 1-10 | TYRES AND WHEELS 2-6 |
| Instrument Panel B (OPTIONAL) 1-10 | HOW TO CHANGE THE TYRES 2-7 |
| Instrument Panel C (OPTIONAL) 1-10 | General 2-7 |
| Temperature Indicator Lamp 1-11 | PNEUMATIC TYRES 2-7 |
| SAFE MAINTENANCE PROCEDURES 1-11 | Remove the Wheel from the Lift Truck 2-7 |
| MOVING A DISABLED LIFT TRUCK 1-12 | Remove the Tyre from the Wheel 2-8 |
| HOW TO TOW THE LIFT TRUCK 1-12 | Install the Tyre on the Wheel 2-8 |
| HOW TO PUT A LIFT TRUCK ON BLOCKS 1-12 | Add Air to the Tyres 2-9 |
| HOW TO RAISE THE STEERING TYRE 1-13 | PNEUMATIC SHAPED SOLID TYRES 2-10 |
| HOW TO RAISE THE DRIVE TYRES 1-13 | Remove the Wheel from the Lift Truck 2-10 |
| PRECAUTIONS FOR TRUCKS IN STORAGE 1-13 | Remove the Tyre from the Wheel 2-10 |
| PRECAUTIONS FOR BATTERIES | Install the Tyre on the Wheel 2-11 |
| IN STORAGE 1-14 | SOLID TYRES 2-12 |
| | Remove the One Piece Wheel and Tyre .. 2-12 |
| | Install the Tyre on the One Piece Wheel .. 2-12 |
| | Install the Wheels on the Lift Truck 2-12 |
| | LABEL REPLACEMENT 2-13 |
| | YALE WARRANTY INFORMATION 2-14 |
| | RECOMMENDED SCHEDULE |
| | OF MAINTENANCE 2-14 |
| | LUBRICATION INSTRUCTIONS 2-15 |
| | EVERY 8 HOURS 2-15 |
| | EVERY 350 HOURS 2-15 |
| | EVERY 2000 HOURS 2-15 |
| | HYDRAULIC OILS 2-21 |
| | GEAR OILS 2-22 |
| | GREASE 2-23 |
| | FREEZER APPLICATIONS 2-24 |
| | Modifications 2-24 |
| | Complete Truck 2-24 |
| | Control Compartment 2-24 |
| | Electrical System 2-24 |
| | Battery Compartment 2-24 |
| | Ignition Switch 2-24 |
| | Steering Linkage and Pivot Points 2-24 |
| | Accelerator Pedal 2-24 |
| | Drive, Hydraulic and Steering Motors 2-24 |
| | |
| Section 2 | |
| GENERAL 2-1 | |
| FRAME 2-1 | |
| FLOOR PLATE 2-1 | |
| REAR COMPARTMENT COVER 2-1 | |
| FRONT COVER 2-2 | |
| STEERING COLUMN COVER 2-2 | |
| HYDRAULIC CONTROL VALVE COVERS 2-2 | |
| BATTERY COVER 2-2 | |
| Open 2-2 | |
| Close 2-2 | |
| Removal 2-2 | |
| Installation 2-2 | |
| BATTERY REMOVAL AND INSTALLATION 2-3 | |
| BATTERY PLATFORM 2-3 | |
| OVERHEAD GUARD 2-4 | |
| Removal 2-4 | |
| Installation 2-4 | |
| COUNTERWEIGHT 2-4 | |
| Removal 2-5 | |
| Installation 2-5 | |

Section 2

| | |
|--|-------------|
| Brake Lines and Linkage | 2-24 |
| Tilt Cylinders | 2-24 |
| Upright and Carriage | 2-24 |
| MAINTENANCE | 2-24 |
| Complete Truck | 2-24 |
| Control Compartment | 2-24 |
| Electrical System | 2-25 |
| Battery Compartment | 2-25 |
| Ignition Switch | 2-25 |
| Steering Linkage and Pivot Points | 2-25 |
| Accelerator Pedal | 2-25 |
| Drive, Hydraulic and Steering Motors | 2-25 |
| Brake Lines and Linkage | 2-25 |
| Tilt Cylinders | 2-25 |
| Upright and Carriage | 2-25 |
| Hydraulic System | 2-25 |
| FASTENERS - INTRODUCTION | 2-26 |
| Threads, Nomenclature | 2-26 |
| Strength Identification | 2-26 |

Section 3

| | |
|---|-------------|
| ELECTRICAL SYSTEM-GENERAL | 3-1 |
| EV-100LX MOTOR CONTROLLER | 3-2 |
| EV-100 DESCRIPTION AND OPERATION | 3-2 |
| The Silicon Controlled Rectifier | 3-2 |
| A Motor Circuit that Operates with Pulses | 3-2 |
| Traction Circuit | 3-4 |
| Hydraulic Pump Motor | 3-4 |
| The SCR 1 "OFF" Circuit | 3-4 |
| INDUCTION CURRENT FROM THE MOTOR | 3-6 |
| THE CONTROL CARD | 3-7 |
| Pulse Monitor Trip | 3-8 |
| SRO Circuit | 3-8 |
| Control Card Adjustments | 3-8 |
| Accelerator Control | 3-11 |
| CONTROL CARD | 3-11 |
| Status Codes | 3-11 |
| SEQUENCE OF OPERATION | 3-12 |
| SCR CONTROL | 3-14 |
| CONTROL CARD CONNECTIONS | 3-14 |
| HAND SET | 3-17 |
| CHECKS AND ADJUSTMENTS, CONTROL CARD | 3-18 |
| Function Codes | 3-18 |
| Bench Tests | 3-19 |
| Tests-Control Card Installed in a Lift Truck | 3-19 |
| FUNCTION SETTINGS | 3-20 |

Section 3

| | |
|---|-------------|
| General | 3-20 |
| Connect, Disconnect, and Check the Hand Set | 3-20 |
| Check and Adjust Functions | 3-20 |
| FUNCTION DESCRIPTIONS | 3-21 |
| Traction Control Cards | 3-21 |
| PUMP CONTROL CARD (LABEL LETTER PX) | 3-23 |
| TABLES FOR FUNCTION VALUE SETTINGS | 3-24 |
| TROUBLESHOOTING | 3-26 |
| CONTACTORS | 3-59 |
| TESTING CONTACTORS | 3-59 |
| Removal | 3-60 |
| Installation | 3-60 |
| TMM 1 CARD | 3-62 |
| Removal | 3-63 |
| Installation | 3-63 |
| CIRCUIT PROTECTION | 3-63 |
| Current Limit | 3-63 |
| Thermal Protection | 3-63 |
| Suppressors (Filter Blocks) | 3-63 |
| FUSES | 3-64 |
| PRINTED CIRCUIT BOARDS | 3-64 |
| Steering Angle Control Board | 3-64 |
| Operation | 3-64 |
| Testing | 3-65 |
| Lift Pump Control Board | 3-69 |
| Operation | 3-69 |
| Testing | 3-70 |
| Bypassing the Lift Pump Control Board | 3-71 |
| ACCELERATOR | 3-72 |
| Removal | 3-72 |
| Installation | 3-72 |
| POWER STEERING | 3-73 |
| KEY SWITCH | 3-73 |
| INSTRUMENT PANEL | 3-73 |
| Standard Instrument Panel | 3-74 |
| MOTOR MAINTENANCE - GENERAL | 3-75 |
| BRUSH AND COMMUTATOR INSPECTION | 3-75 |
| NORMAL COMMUTATOR SERVICE | 3-77 |
| COMMUTATOR PROBLEMS | 3-78 |
| BRUSH REPLACEMENT, DRIVE AND HYDRAULIC PUMP MOTORS | 3-80 |
| Traction Motor Removal | 3-82 |
| Hydraulic Pump Motor Installation | 3-83 |
| Power Steering Pump Motor | 3-83 |
| MOTOR REMOVAL AND INSTALLATION | 3-83 |
| Traction Motor | 3-83 |
| Traction Motor Installation | 3-83 |

Section 3

| | |
|--|-------------|
| Lift Pump and Motor Removal | 3-84 |
| Lift Pump and Motor Installation | 3-84 |
| Power Steering Pump and Motor Removal | 3-84 |
| Power Steering Pump and Motor Installation | 3-85 |
| TRACTION MOTOR REPAIR | 3-85 |
| Disassembly | 3-85 |
| Assembly | 3-85 |
| COMMUTATOR REPAIRS | 3-85 |
| TESTS | 3-87 |
| Damaged Field and Armature | 3-87 |
| Short-Circuit in an Armature Winding | 3-88 |
| Short-Circuit in the Armature | 3-88 |
| Open Circuit in a Field Coil | 3-88 |
| Short-Circuit in a Field Coil | 3-88 |
| Short-Circuit Between Field and Motor Case | 3-88 |
| Brush Holder | 3-88 |
| WIRING DIAGRAMS AND SCHEMATICS | 3-90 |

Section 4

| | |
|---------------------------------------|------------|
| TRANSAXLE-GENERAL | 4-1 |
| TRANSAXLE SPECIFICATIONS | 4-1 |
| REMOVAL | 4-1 |
| INSTALLATION | 4-3 |
| DISASSEMBLY | 4-3 |
| ASSEMBLY | 4-3 |
| TROUBLESHOOTING | 4-6 |

Section 5

| | |
|---|------------|
| GENERAL | 5-1 |
| SPECIFICATIONS | 5-1 |
| PARKING BRAKE ADJUSTMENT | 5-1 |
| SERVICE BRAKE ADJUSTMENT | 5-1 |
| REMOVAL-SERVICE BRAKE PADS | 5-1 |
| INSTALLATION-SERVICE BRAKE PADS | 5-1 |
| REMOVAL-SERVICE BRAKE CALIPER | 5-2 |
| INSTALLATION-SERVICE BRAKE CALIPER | 5-3 |
| DISASSEMBLY-SERVICE BRAKE CALIPER | 5-3 |
| ASSEMBLY-SERVICE BRAKE CALIPER | 5-3 |
| REMOVAL-PARKING BRAKE CALIPER | 5-3 |
| INSTALLATION-PARKING BRAKE CALIPER | 5-4 |
| DISASSEMBLY-PARKING BRAKE CALIPER | 5-6 |
| ASSEMBLY-PARKING BRAKE CALIPER | 5-6 |
| MASTER CYLINDER-REMOVAL | 5-6 |
| MASTER CYLINDER-INSTALLATION | 5-6 |
| MASTER CYLINDER-DISASSEMBLY | 5-6 |
| MASTER CYLINDER-ASSEMBLY | 5-7 |
| PARKING BRAKE LEVER ASSEMBLY-REMOVAL | 5-7 |

Section 5

| | |
|--|------------|
| PARKING BRAKE LEVER ASSEMBLY-INSTALLATION | 5-7 |
| TROUBLESHOOTING | 5-9 |

Section 6

| | |
|---|-------------|
| TRAIL AXLE | 6-1 |
| WHEEL ASSEMBLY | 6-1 |
| Removal | 6-1 |
| Installation | 6-1 |
| WHEEL HUB | 6-1 |
| Removal | 6-1 |
| Installation | 6-1 |
| STEER AXLE ASSEMBLY | 6-3 |
| Removal | 6-3 |
| Installation | 6-3 |
| POWER STEERING SYSTEM | 6-4 |
| General | 6-4 |
| Description | 6-4 |
| STEERING WHEEL AND COLUMN ASSEMBLY | 6-4 |
| Removal | 6-5 |
| Installation | 6-6 |
| Cleaning | 6-8 |
| Disassembly | 6-8 |
| Assembly | 6-10 |
| Installation | 6-13 |
| POWER STEERING CYLINDER | 6-14 |
| Removal | 6-14 |
| Installation | 6-14 |
| Disassembly | 6-14 |
| Assembly | 6-14 |
| CHECKS AND ADJUSTMENTS | 6-14 |
| Remove Air from the System | 6-14 |
| Check the Operation | 6-15 |
| Steering Pressure | 6-15 |
| TROUBLESHOOTING | 6-16 |

Section 7

| | |
|----------------------------------|------------|
| GENERAL | 7-1 |
| HOIST SYSTEM | 7-1 |
| TILT SYSTEM | 7-1 |
| AUXILIARY FUNCTIONS | 7-1 |
| Third Function Location | 7-1 |
| Fourth Function Location | 7-1 |
| HYDRAULIC OIL TANK | 7-1 |
| SPECIFICATIONS | 7-2 |
| Hydraulic Tank | 7-2 |
| Hoist Pump | 7-2 |
| Power Steering Pump | 7-2 |

Section 7

| | |
|--|------|
| Strainers | 7-2 |
| Hydraulic Oil Filter | 7-2 |
| HOIST PUMP | 7-3 |
| Removal | 7-3 |
| Installation | 7-4 |
| Disassembly-Seal Replacement | 7-4 |
| Assembly | 7-4 |
| POWER STEERING PUMP AND MOTOR | 7-5 |
| Removal | 7-5 |
| Installation | 7-5 |
| Disassembly | 7-6 |
| Assembly | 7-6 |
| CONTROL VALVE | 7-7 |
| Settings | 7-7 |
| Removal | 7-7 |
| Installation | 7-8 |
| Disassembly | 7-10 |
| Assembly | 7-10 |
| MAST TILT ADJUSTMENT | 7-12 |
| CONTROL VALVE-EMERGENCY REPAIR .. | 7-12 |
| TROUBLESHOOTING | 7-13 |

Section 8

| | |
|---|------|
| MAST | 8-1 |
| DESCRIPTION AND OPERATION | 8-1 |
| Carriage | 8-1 |
| Mast Mounts | 8-1 |
| TWO STAGE MAST WITH LIMITED FREE LIFT 8-3 | |
| Description and Operation | 8-3 |
| TWO STAGE MAST WITH FULL FREE LIFT ... | 8-5 |
| Description | 8-5 |
| Operation | 8-5 |
| THREE STAGE MAST WITH FULL FREE LIFT . | 8-7 |
| Description | 8-7 |
| Operation | 8-7 |
| SAFETY PROCEDURES WHEN WORKING NEAR THE MAST | 8-9 |
| MAST REPLACEMENT | 8-9 |
| MAST REPAIRS | 8-10 |
| FORKS | 8-10 |
| Removal | 8-10 |
| Installation | 8-10 |
| CARRIAGES | 8-10 |
| Removal, Standard Carriage | 8-10 |
| Removal, Sideshift Carriage | 8-12 |
| Repairs | 8-12 |
| Installation, Standard Carriage | 8-12 |

Section 8

| | |
|---|------|
| Installation, Sideshift Carriage | 8-12 |
| MASTS | 8-13 |
| Removal | 8-13 |
| Disassembly Procedures for the Two Stage Mast with Limited or Full Free Lift | 8-14 |
| Disassembly Procedures for the Three Stage Mast | 8-17 |
| Cleaning and Inspection | 8-19 |
| Assembly of the Two Stage Mast with Limited and Full Free Lift | 8-20 |
| Assembly of the Three Stage Mast with Full Free Lift | 8-20 |
| Mast Installation | 8-21 |
| LIFT CYLINDERS | 8-21 |
| Removal of the Main Lift Cylinders | 8-21 |
| Removal of the Free Lift Cylinder | 8-22 |
| Disassembly of a Lift Cylinder | 8-22 |
| Assembly of a Lift Cylinder | 8-22 |
| Installation of the Main Lift Cylinders | 8-24 |
| Installation of the Free Lift Cylinder | 8-25 |
| HEADER HOSE ARRANGEMENTS | 8-25 |
| Installation of Header Hoses for Two Stage Mast with Limited Free Lift | 8-26 |
| Installation of Header Hoses for Two Stage Mast with Full Free Lift | 8-27 |
| Installation of Header Hoses for Three Stage Mast with Full Free Lift | 8-30 |
| TILT CYLINDERS | 8-33 |
| Removal | 8-33 |
| Disassembly | 8-33 |
| Cleaning | 8-34 |
| Assembly | 8-34 |
| Installation | 8-34 |
| CHECKS AND ADJUSTMENTS | 8-34 |
| Check the Lift Cylinders for Leaks | 8-34 |
| Check the Tilt Cylinders for Leaks | 8-34 |
| Adjust the Tilt Cylinders | 8-34 |
| Adjust the Lift Chains | 8-35 |
| Adjust the Mast | 8-36 |
| Adjust the Carriage | 8-36 |
| TROUBLESHOOTING | 8-38 |

Section 9

| | |
|--|-----|
| BATTERY AND CHARGING SYSTEM- GENERAL | 9-1 |
| SAFETY TIPS FOR HANDLING INDUSTRIAL TRUCK BATTERIES | 9-1 |
| LEAD ACID BATTERIES | 9-2 |
| Specific Gravity | 9-3 |
| Chemical Reaction | 9-3 |

Section 9

| | |
|--------------------------------------|-----|
| HOW TO SELECT THE BATTERY | 9-4 |
| Voltage of a Battery | 9-4 |
| Battery Ratings | 9-4 |
| Kilowatt Hours | 9-4 |
| THE BATTERY AS A COUNTERWEIGHT | 9-5 |
| THE NEW BATTERY | 9-5 |
| BATTERY MAINTENANCE | 9-5 |
| Maintenance Records | 9-5 |
| Cleaning the Battery | 9-6 |
| Adding Water | 9-6 |
| Hydrometer | 9-7 |
| Battery Temperature | 9-7 |
| CHARGING THE BATTERY | 9-8 |
| Types of Battery Charges | 9-8 |
| Methods of Charging | 9-8 |
| Troubleshooting the Charger | 9-9 |

Section 9

| | |
|--|------|
| How to Know when the Battery is Fully Charged | 9-9 |
| Battery Charging Area | 9-9 |
| Equipment Needed | 9-9 |
| TROUBLESHOOTING | 9-10 |

Section 10

| | |
|----------------------------------|------|
| SERVICE PARTS | |
| ORDERING INSTRUCTIONS | 10-1 |
| HOW TO ORDER SERVICE PARTS | 10-1 |
| WHEN ORDERING PARTS | 10-1 |
| TECHNICAL PUBLICATIONS | 10-1 |
| PARTS MANUAL | 10-1 |
| OPERATING MANUAL | 10-1 |
| OPERATOR TRAINING | 10-1 |
| SERVICE TRAINING COURSES | 10-1 |
| SERVICE TRAINING MATERIALS | 10-1 |

| | |
|----------|-------------------------------|
| 1 | OPERATING INSTRUCTIONS |
|----------|-------------------------------|

CONTENTS

| | |
|---|------|
| <i>FORK ADJUSTMENT</i> | 1-4 |
| <i>GENERAL</i> | 1-1 |
| <i>HOW TO PUT A LIFT TRUCK ON BLOCKS</i> | 1-12 |
| <i>HOW TO RAISE THE DRIVE TYRES</i> | 1-13 |
| <i>HOW TO RAISE THE STEERING TYRE</i> | 1-13 |
| <i>HOW TO TOW THE LIFT TRUCK</i> | 1-12 |
| <i>MODEL AND CONTROL INFORMATION</i> | 1-7 |
| <i>Instrument Panel A (STANDARD)</i> | 1-10 |
| <i>Instrument Panel B (OPTIONAL)</i> | 1-10 |
| <i>Instrument Panel C (OPTIONAL)</i> | 1-10 |
| <i>Temperature Indicator Lamp</i> | 1-11 |
| <i>MOVING A DISABLED LIFT TRUCK</i> | 1-12 |
| <i>OPERATOR PRECAUTIONS</i> | 1-2 |
| <i>OPERATING PROCEDURE</i> | 1-3 |
| <i>OPERATOR PRE-CHECKS AND INSPECTION</i> | 1-3 |
| <i>PRECAUTIONS FOR BATTERIES IN STORAGE</i> | 1-14 |
| <i>PRECAUTIONS FOR TRUCKS IN STORAGE</i> | 1-13 |
| <i>SAFETY AND INFORMATIONAL LABELS</i> | 1-2 |
| <i>SAFETY AND OPERATIONAL CHECK LIST</i> | 1-5 |
| <i>SAFE MAINTENANCE PROCEDURES</i> | 1-11 |
| <i>SHUT DOWN PROCEDURE</i> | 1-4 |

GENERAL

Before attempting to operate this truck, carefully read and understand these operating procedures.

Make sure the truck is in proper operating condition. Be sure all safety devices such as the overhead guard and the load backrest extension are in place and properly secured. Visually inspect the entire truck for any damage that may have occurred during shipment.

NOTE: Throughout this manual the terms right, left, front and rear relate to the viewpoint of an operator walking with or riding on the truck.

Familiarise yourself with the information contained on the name plate which is located on the cowl to the left of the steering column. See Figure 1-1 and Figure 1-2. Information on this name plate is as follows:

1. Serial Number - This is an identification number assigned to this particular truck and should be used when ordering service parts or when requesting any information from your Yale Industrial Truck Dealer. The serial number is a six digit number preceded by a letter and is stamped on the truck frame and on the name plate.
2. Model Code - An explanation of the model code is located on the back of the front cover of this manual.

3. Truck Weight - This is the approximate weight of the truck without a load on the forks. This weight plus the weight of the load to be moved must be considered when operating on raised floors, lifts, etc.

4. Capacity Rating - This rating shows the maximum load capacity of this truck with relation to load centres and fork heights (see diagram on name plate). Personal injury and damage to the truck can occur if the capacity rating is exceeded.

Safety and informational labels are located in conspicuous locations on this truck and should be strictly followed. Check the name plate of each truck before operation. These safety and informational labels must be replaced immediately if missing or defaced. Labels will vary with type of truck and equipment installed. Refer to the Parts Manual for part number and location for all labels. The location of the labels is also shown in Section 2, GENERAL TRUCK AND LUBRICATION.

This truck meets all applicable mandatory requirements and safety standards for powered industrial trucks at the time of manufacture.

No additions, omissions or modifications should be made that will affect compliance to the previously stated requirements or in any way minimize the effectiveness of the safety devices.

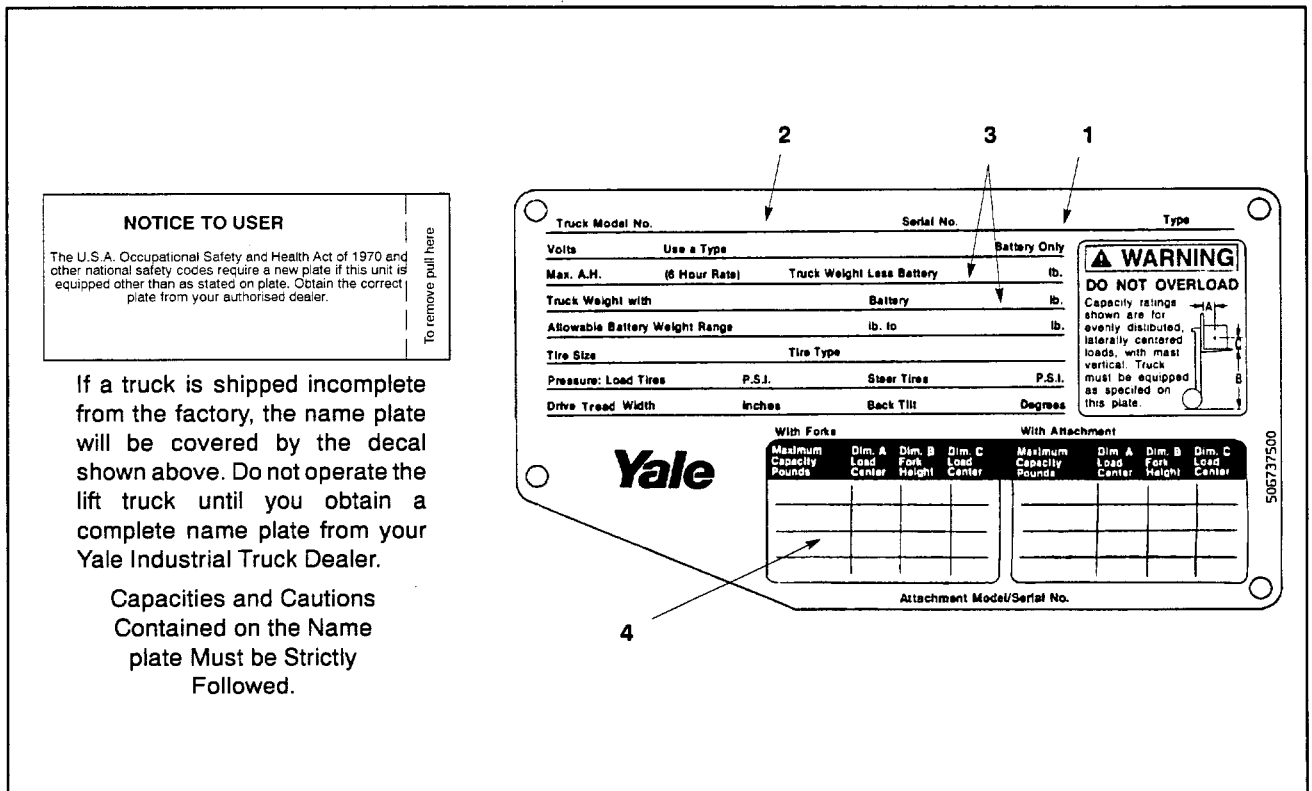

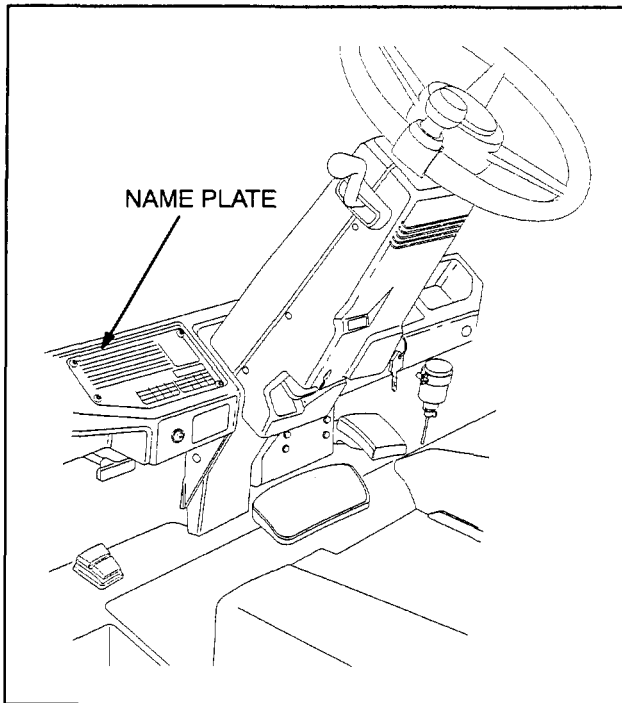
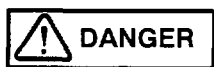

Figure 1-2 - Name Plate Location

SAFETY AND INFORMATIONAL LABELS

Safety and informational labels are located in conspicuous locations on this truck and should be strictly adhered to. These safety and informational labels *must be replaced immediately if missing or defaced*. Labels will vary with type of truck and equipment installed. Refer to Parts Manual for part number of labels.

HAZARD INTENSITY LEVEL



DANGER: Identified by a Red Label, immediate hazards which **WILL** result in severe personal injury or death.



WARNING: Identified by an Orange Label, hazards or unsafe practices which **MAY** result in personal injury or death.

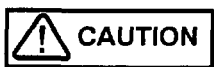

CAUTION: Identified by a Yellow Label, hazards or unsafe practices which **MAY** result in minor personal injury or product or property damage.

THE READER MAY FIND ANY OR ALL OF THE FOLLOWING LABELS USED IN THIS PUBLICATION. AN UNDERSTANDING OF THEIR USE, AS GIVEN BELOW WILL AID THE READER.

NOTE

An advisory procedure, practice, condition, etc., which is essential to emphasize.



Directs attention to hazards or unsafe practices which may result in minor personal injury, product or property damage if the proper precautions are not taken.



Directs attention to unsafe practices which could result in personal injury or death if proper precautions are not taken.



Directs attention to unsafe practices and/or existing hazards which **WILL** result in severe personal injury or death if proper precautions are not taken.

OPERATOR PRECAUTIONS

The following precautions have been prepared for your safety and the safety of your fellow workers. Read and understand this information before operating the lift truck.



WARNING: Use special care when travelling without a load as **THE RISK OF OVERTURNING IS GREATER** when cornering and at high speed.

Check all gauges and indicator lights for correct operation. Frequent reading of the instrument panel should be a habit.

Follow the Recommended Schedules of Maintenance. Maintain your lift truck for dependable and economical operation.

Report all accidents involving personnel, building structures and equipment to the proper authority.

Before each shift, every 8 hours, it is the operator's responsibility to carry out the following checks and inspections before beginning truck operation. Do not operate truck if it is in need of repair, if it is in an unsafe condition, or might contribute to an unsafe condition. Remove the key and report the condition to the proper authority. If the truck becomes unsafe in any way while you are operating it, **STOP operating the truck and report the matter immediately to the proper authority.**

Basic maintenance information and the Recommended Schedule of Maintenance are in the Operating Manual, located in the document holder on the compartment cover. Also refer to Section 2, GENERAL TRUCK AND LUBRICATION.

1. Make sure overhead guard, load backrest extension, and all other protective equipment is attached.
2. Make sure all capacity, safety and informational plates or labels are attached. This truck is not considered safe to use without a legible, properly filled out name plate. Contact Yale Materials Handling Corporation or your local dealer for Yale industrial trucks if the name plate is not present and legible. See Section 2, GENERAL TRUCK AND LUBRICATION or the Parts Manual for label and plate locations.
3. Inspect truck for any damage that might have occurred during the previous shift.
4. Inspect truck before and after operating, for any signs of external leaking of the battery, steering system, hydraulic system, etc.
5. Check hydraulic hoses for leaking, chafing, cuts or reinforcement showing through the outside of the hose.
6. Check for mistracking of the hoses on the sheaves.
7. Make sure chains are not damaged or kinked.
8. Make sure mast stops and finger guards are in place.
9. Make sure bonnet latches are adjusted (if equipped) and fastened.
10. Operate service and parking brakes, all hydraulic controls, (lift, tilt and auxiliary, if equipped), accelerator, shifting linkages and steering. Make sure they operate freely and return to their proper positions. See section on OPERATING CONTROLS for detailed descriptions.
11. Inspect condition of wheels and tyres.
12. Inspect forks for any damage. Make sure they are properly attached and locking clips are in their proper position.
13. Test horn, lights and all other accessories. Make sure they are properly mounted and in good working order.
14. Operate truck and make sure all gauges and meters are functioning properly.
15. Make sure any unusual noises are investigated immediately.

OPERATOR PRE-CHECKS AND INSPECTION

1. When attachments are used, extra care should be taken in securing, positioning and transporting the load. Operate trucks equipped with attachments as partially loaded trucks.

2. Watch that your load does not exceed the capacity rating of the truck. The truck capacity is posted on the name plate which is attached to the truck at the factory.
3. Do not handle unstable or loosely stacked loads.
4. Do not start or operate this truck or any of its functions or attachments if you are not in the operator's seat, which is the designated operator's position for this Yale lift truck.
5. Never allow anyone to ride on your truck and never allow anyone other than a qualified professional to operate your truck.
6. Refer to the Maintenance and Lubrication section in this manual for the recommended hourly service intervals. Regular attention at the specified time will pay dividends in maximum efficiency and longer life of the truck.

OPERATING PROCEDURE

Apply power to the truck by connecting the battery plug to the truck receptacle. Be sure the plug is fully inserted and locked into place so that there is enough pressure at the contact mating surfaces.

Make sure the direction control levers are in the neutral position before operating the truck.

- The operator must sit on the seat to energise the electrical circuit.
- Place foot on the service brake pedal.
- Turn key toward forks (clockwise).
- Release the parking brake.
- Select desired direction.
- Release service brake pedal.
- Depress accelerator pedal to travel.



CAUTION: Operating the drive control in a situation where the truck will not move will damage the electric motor.

1. Keep hands, feet and other parts of your body inside the operator's compartment. Parts of your body outside the truck can be injured when passing obstructions.
2. Do not permit passengers to ride on the truck.
3. Observe and comply with instructions concerning floor loadings. Know the weight of your truck and load combined. Truck weight information is located on the name plate.
4. Travel with the lifting mechanism low and where possible, tilted back. Do not elevate the load except during stacking.

5. The operator can change the direction of travel while the lift truck is moving by moving the direction control lever in the opposite direction. This is called plugging.
6. Look in the direction of travel and keep a clear view of the path of travel.
7. If visibility is impaired by the load, operate truck with the forks trailing and always look in the direction of travel.
8. Start, stop, travel, steer and brake smoothly. Slow down for turns and on uneven or slippery surfaces that could cause truck to overturn or slide.
9. Before entering trucks or trailers, be certain the brakes on the truck or trailer are applied and wheel chock(s) are in place. If trailers are not coupled to a tractor, supports may be needed to prevent upending or corner dipping. Check the flooring of trucks, trailers and railroad cars for breaks and weakness before driving onto them.
10. Before driving over a dock board or bridge plate, be certain that it is properly secured. Drive carefully and slowly across the dockboard or bridge plate and never exceed its rated capacity.
11. Maintain a safe distance from the edge of ramps or platforms. Do not push freight cars while on a raised dock or platform. Do not use this truck for opening or closing freight doors.
12. Watch clearances, especially around forks. The driver must be aware that the forks can sometimes extend beyond the load. This may cause the forks to hit an object or lift another load.
13. Watch out for obstructions, especially overhead. Check clearances.
14. Do not run over objects on the roadway surface as truck stability and steering may be adversely affected.
15. When approaching cross aisles, slow down, sound horn and keep to the right side of aisle.
16. Operate truck under all conditions at a speed that will permit it to be brought to a stop in a safe manner.
17. On sloping surfaces, higher than 5 percent (a 5 ft. rise or drop in 100 ft. of travel), operate loaded truck with the load facing up hill. Do not turn on a slope. For stability reasons, a lift truck must not be driven across a slope.
18. Operate unloaded truck on all grades with the lifting mechanism downhill.
19. Do not push extra loads with the truck.

20. Watch out for pedestrians at all times. Do not drive up to anyone standing in front of an object.



21. Observe all traffic regulations, including authorised plant speed limits. Under normal traffic conditions, keep to the right. Maintain a safe distance from the truck ahead (approximately three truck lengths), and keep the truck under control at all times.
22. Yale lift trucks are not intended for use on public roads.
23. When leaving truck unattended, lower the lifting mechanism, shut off power, remove key and apply parking brake. Chock wheels if truck is parked on an slope.
24. Do not remove overhead guard or load backrest extension unless specifically authorised.
25. Always set the forks as far apart as the load will permit. Make sure that fork length is at least 2/3 of load length.
26. Carry the load flush against the truck.
27. Do not put any part of your body into the mast area or between the mast and truck. Be aware of pinch points on attachments, especially reach mechanisms.
28. Allow no one under or near load or lifting mechanism.
29. If a supplementary platform is used, make sure it is securely fastened to the carriage and forks.

SHUT DOWN PROCEDURE

When leaving the truck, fully lower lifting mechanism, ensure controls are in neutral, shut off power, apply the brake, and remove key. If you park the truck on an slope, chock the wheels.

FORK ADJUSTMENT

Adjust the forks on the fork carriage. Forks should be spaced as far apart as the load being moved will allow. Both forks should always be the same distance from the centre of the fork carriage.

Check for the presence and condition of studs at each end of the carriage upper fork clip slide. If studs are damaged or missing they should be repaired or replaced before the forks are adjusted.

To adjust the forks, raise them a few inches off the floor. Lift up on the keeper pin and slide the forks along the carriage by pushing them away from you. Do not pull the forks toward you. When the forks are set to the desired position, make sure the keeper pin is down in a slot on the top of the fork carriage plate.

SAFETY AND OPERATIONAL CHECK LIST

A "Daily Check List" similar to the one shown on the next page should be used every day before operating the truck.

The check lists are available in tablet form with 50 sheets per tablet and can be obtained from your local Yale Industrial Truck Dealer for a nominal fee.

Both this manual and the Operating Manual contain the Recommended Schedule of Maintenance which should be used as a guide along with the Lubrication Instructions.

Thank you so much for reading.
Please click the “Buy Now!”
button below to download the
complete manual.



After you pay.

You can download the most
perfect and complete manual in
the world immediately.

Our support email:

ebooklibonline@outlook.com