



## Removal and refitting of the oil cooler

- DEUTZ AP1908 assembly product

### NOTE



Collect operating materials in suitable containers and dispose of them in compliance with the applicable regulations. The draining and replenishing of engine fluids and lubricants must be carried out in accordance with the instructions given in the documentation provided by the manufacturer of the vehicle/appliance.

### Removal of the oil cooler

- Remove the oil cooler housing.  
See para. Disassembly and assembly of the oil radiator housing



1.

- Remove the retainer plate (1).



2.

- Remove screws (1).
- Remove the seals.

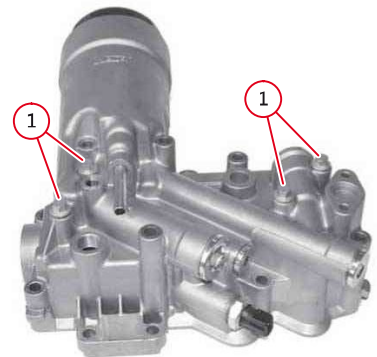

© 465119

3.

- Remove oil cooler (2)
- Carry out a visual inspection of the components.

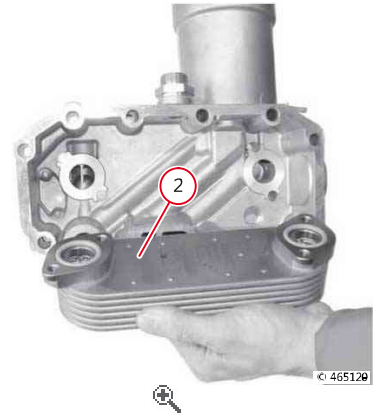

4.

### Refitting the oil cooler

- o Clean the mating surfaces.
- o Apply the assembly product on the O-rings.
- o Fit new O-rings (1).

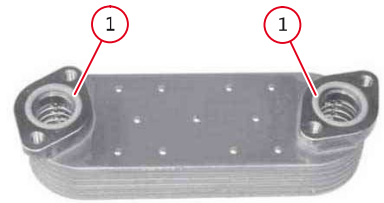

© 465139

1.

- o Align the oil radiator.



**NOTE**

Use new seals.

- o Insert the screws.



© 46514-0

2.

- o Tighten the screws in alternate sequence (1).
- o Tighten the screws (1): 22 Nm.



© 46511-0

3.

- o Fit the retainer plate (1).
- o Assemble the oil radiator housing.  
[See para. Disassembly and assembly of the oil radiator housing](#)



4.

T.\$76.21.B0.06.02.00.01 - v1



## Disassembly and assembly of the oil radiator housing

Commercially available tools:

- Pliers for hose clips: 8011

Special tools:

- Plugs and caps: 170160
- DEUTZ AP1908 assembly product

### NOTE



Collect operating materials in suitable containers and dispose of them in compliance with the applicable regulations. The draining and replenishing of engine fluids and lubricants must be carried out in accordance with the instructions given in the documentation provided by the manufacturer of the vehicle/appliance.

## Disassembly of the oil radiator housing

- Disconnect the wiring connectors.



1.

- Do not fully unscrew drain plug (1).
- Empty, collect and dispose of the coolant in compliance with regulations.

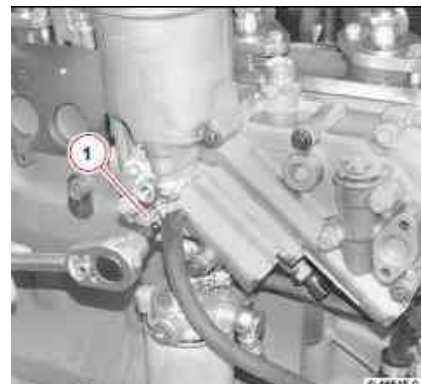

2.

- Loosen the hose clips (1).
- Remove the flexible hose (2).

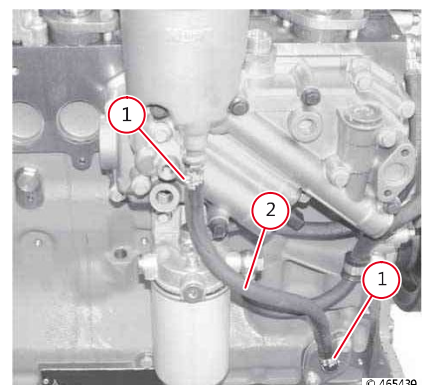

3.

- Unscrew banjo bolt (1)
- Remove the seals.
- Drain, collect and dispose of used oil in accordance with the applicable regulations.

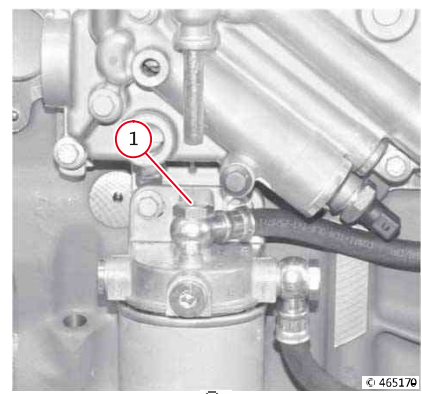

4.

- Remove screws (1).
- Remove fuel filter head (2).

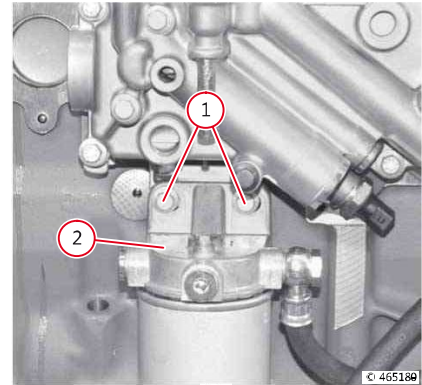

5.

- Remove screws (1).
- Remove oil radiator body (2).
- Remove the gasket.

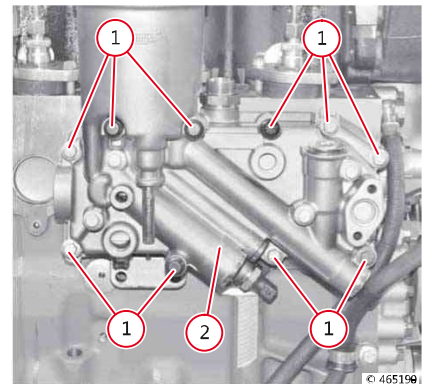

6.

- Carry out a visual inspection of the component.



7.

### Assembly of the oil radiator housing

- Clean the mating surfaces.
- Fit a new O-ring

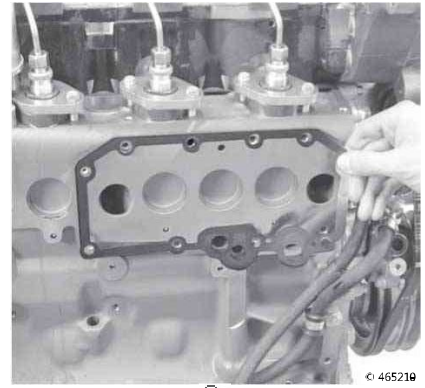

© 465219

1.

- Fit the oil radiator housing.
- Fit the screws.



**NOTE**

Note that the screws are of different lengths M8 x 55 mm (1), M8 x 90 mm (2), M8 x 110 mm (3)

- Tighten the screws in alternate sequence: 30 Nm.

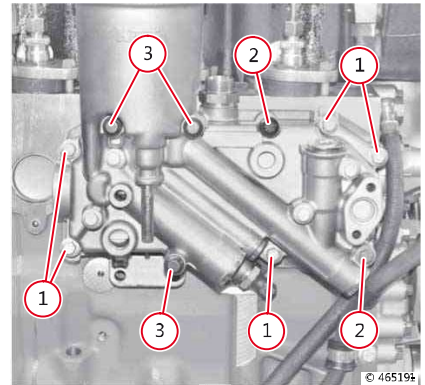

© 465194

2.

- Fit the fuel filter head.
- Fit the nut (1).
- Tighten screws (2).

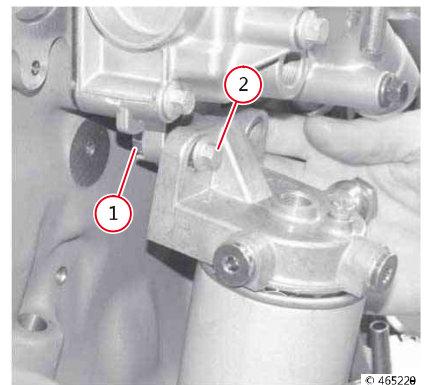

© 465229

3.

- Fit the nut (1).
- Tighten screws (2).
- Tighten the screws: 30 Nm.

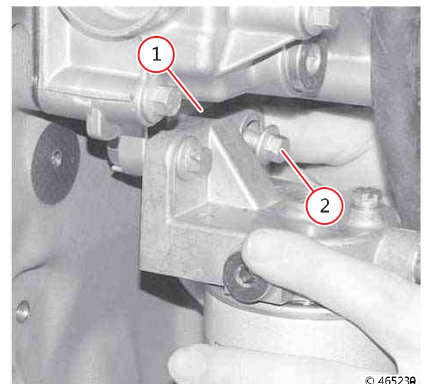

© 465239

4.

- Tighten the hollow screw (1) with the new O-rings: 39 Nm.



**WARNING**

Route the flexible pipe without friction or tension points.

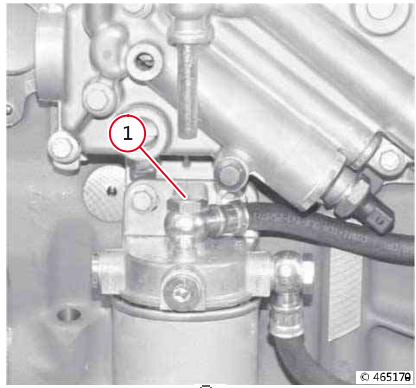

5.

- o Position the hose clips.
- o Fit flexible pipe (1).
- o Secure the hose clips with the special pliers.

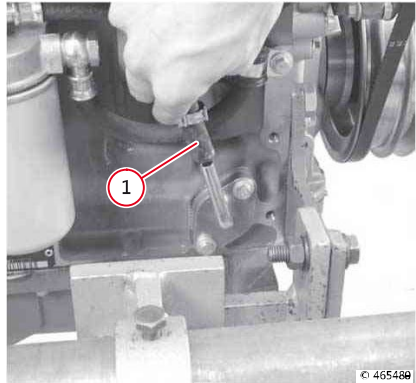

6.

- o Position the hose clips.
- o Fit flexible pipe (1).
- o Secure the hose clips with the special pliers.

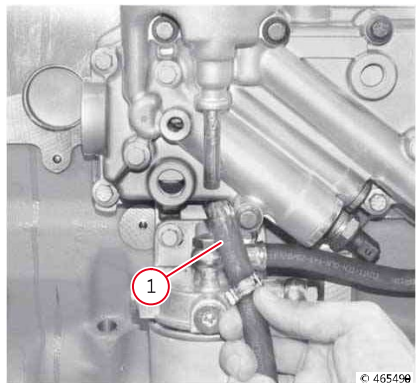

7.

- o Fit a new seal.
- o Fit and tighten plug (1).
- o Re-connect the wiring connectors

<b>NOTE</b>	
	Check that the connection is made correctly. Bleed the fuel system as indicated in the instruction manual, using the hand pump on the fuel pre-filter.

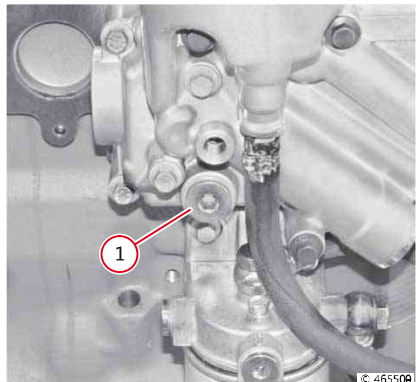

8.



## Removal and refitting of the oil pressure switch

Special tools:

- Long socket wrench insert: 110700
- Plugs and caps: 170160



### NOTE:

Maximum cleanliness is essential when working on the lubricating oil system.



### NOTE:

Thoroughly clean the area around the components to be worked on. Dry any wet areas with a compressed air jet.



### NOTE:

When handling lubricating oils, observe safety standards and all applicable local regulations.



### NOTE:

All lines and unions should be closed immediately after opening using new, clean plugs or caps.



### NOTE:

Remove plugs and caps only immediately prior to assembly.

## Removal of the oil pressure switch

- Unlock and disconnect wiring connectors (1).



1.

- Remove oil pressure switch (1).



### NOTE:

Collect used oil and dispose of it in accordance with the applicable regulations.

- Carry out a visual inspection of the components.

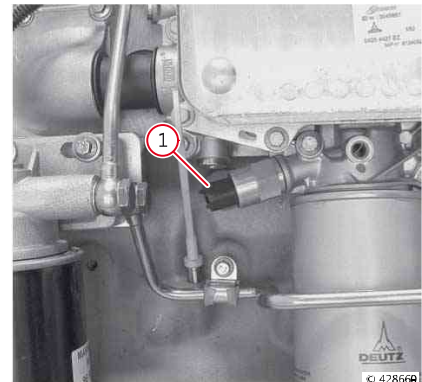

2.

## Fit the oil pressure switch

- Fit and tighten the oil pressure switch (1) with a new O-ring: 40 Nm



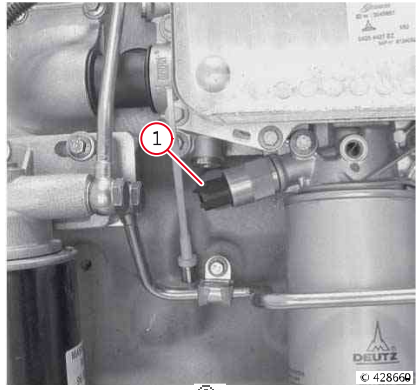

1.

- o Reconnect wiring connector (1).



**NOTE:**

Check that the connection is made correctly.

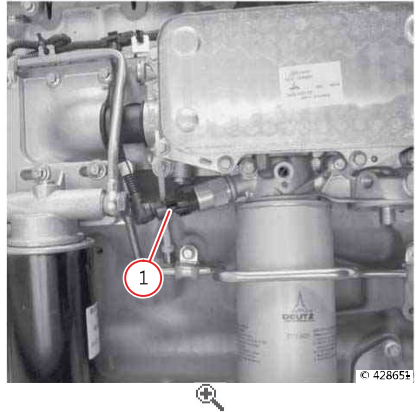

2.



## Removal and refitting of the water pump



### NOTE:

Collect operating materials in suitable containers and dispose of them in compliance with the applicable regulations.



### NOTE:

The draining and replenishing of engine fluids and lubricants must be carried out in accordance with the instructions given in the documentation provided by the manufacturer of the vehicle/appliance.

## Removal of the water pump

- o Disassemble the fan support.  
[See para. Removal and refitting of the fan support](#)
- o Remove the fuel lift pump.  
[See para. Removal and refitting of the fuel lift pump](#)
- o Remove screws (1).



### NOTE:

Collect any leaked coolant and dispose of it in accordance with regulations.

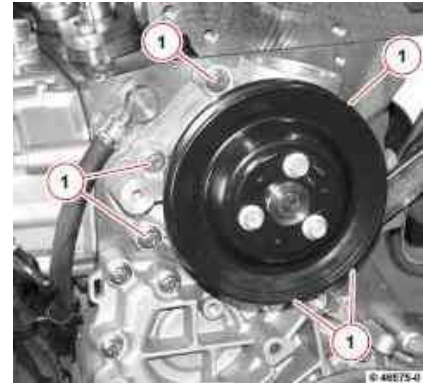

1.

- o Carry out a visual inspection of the components.



2.

## Refitting the water pump



### NOTE

- o The sealing surfaces must be clean, dry and free of grease or other contaminants.
- o Clean the mating surfaces.

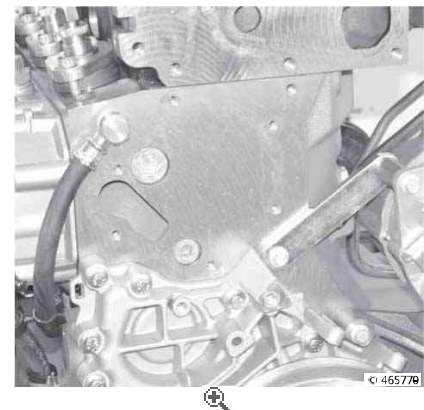

1.

- o Fit a new O-ring
- o Fit water pump (1).

### WARNING

Thank you so much for reading.  
Please click the “Buy Now!”  
button below to download the  
complete manual.



After you pay.

You can download the most  
perfect and complete manual in  
the world immediately.

Our support email:

[ebooklibonline@outlook.com](mailto:ebooklibonline@outlook.com)