

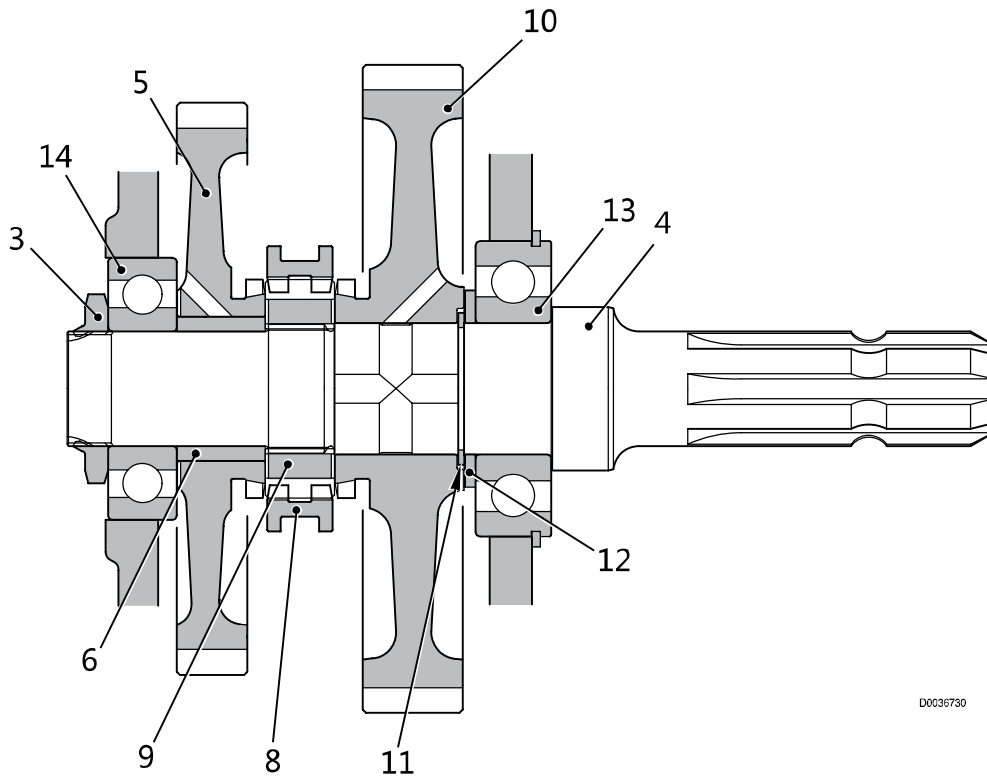

Disassembly of the PTO output shaft - 2-speed version



D0036730

Fig. PTO output shaft.

Disassembly

Drive out spring pin (1).

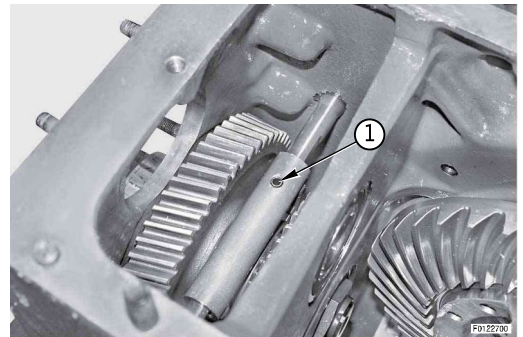

1.

Remove PTO speed selector shaft (2).

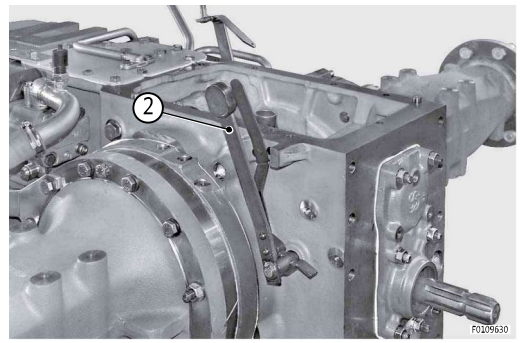

2.

Relieve the staking and remove ringnut (3) using a suitable wrench.

- o Renew the ringnut on reassembly.

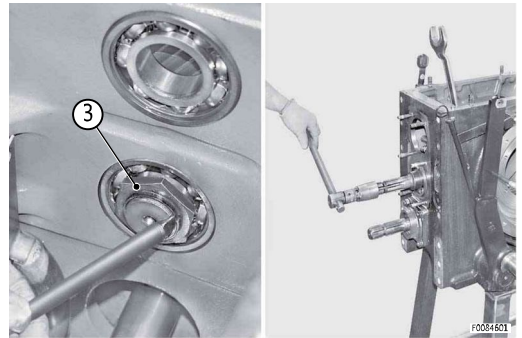

3.

Using a suitable tool, partially withdraw PTO output shaft (4).

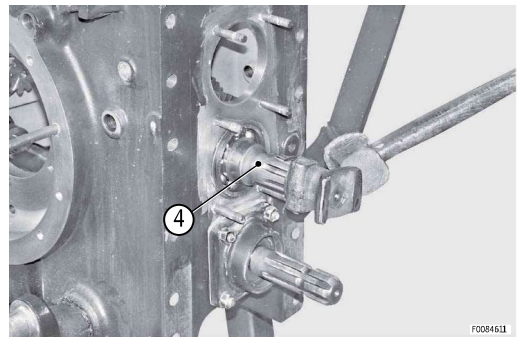

4.

Remove gear (5) complete with bush (6).

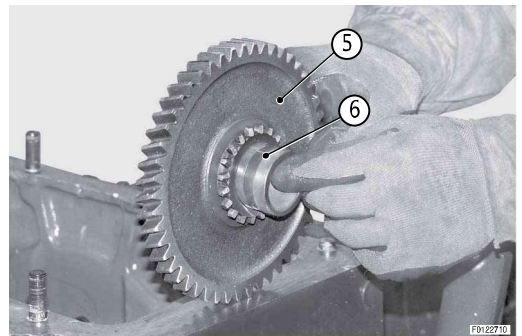

5.

Remove PTO speed selector fork (7).

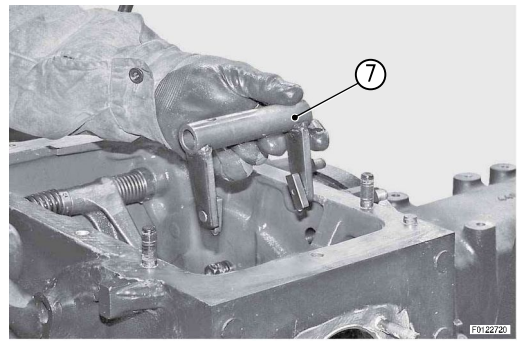

6.

Remove selector sleeve (8) and guide sleeve (9).

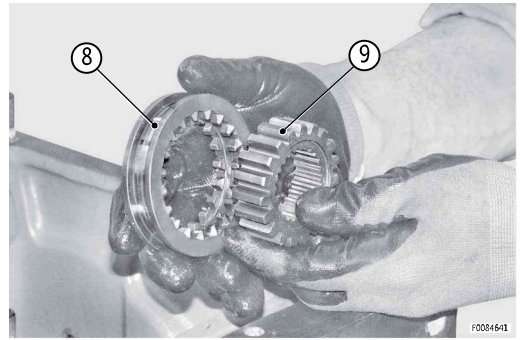

7.

Remove gear (10) and remove shaft assembly (4).

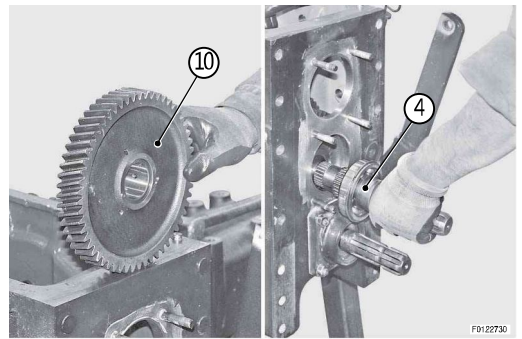

8.

Remove circlip (11) and, using a press, remove thrust washer (12) and bearing (13).

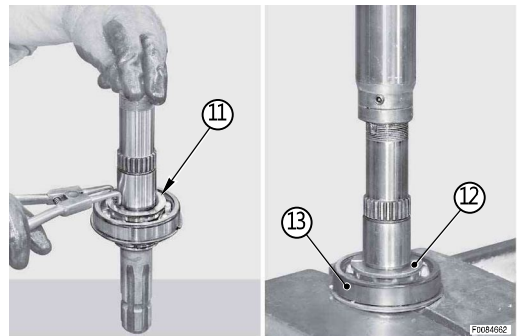

9.

Recover bearing (14).

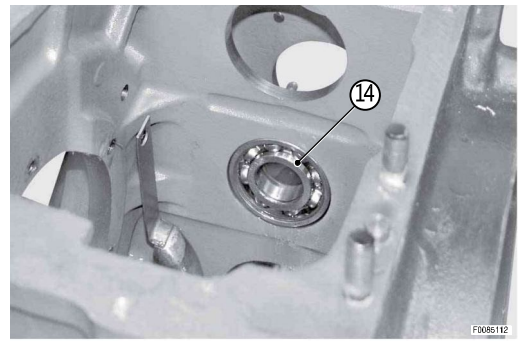

10.

Assembly

To assemble, follow the disassembly steps in reverse order and use caution in relation to the following procedures:

Procedure 9

- Take care to install bearing (13) the right way round relative to shaft (4).

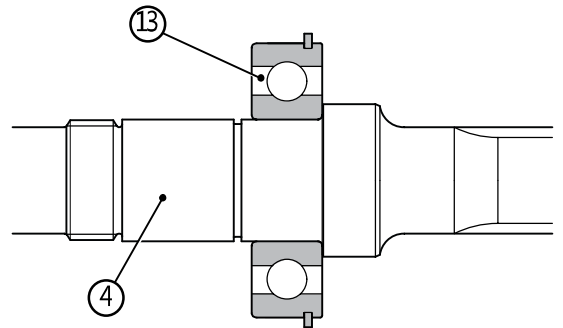

D0024352



Procedure 3

- Nut: 88 ± 1 Nm (64.9 ± 0.74 lb.ft.)
Stake ringnut (3).

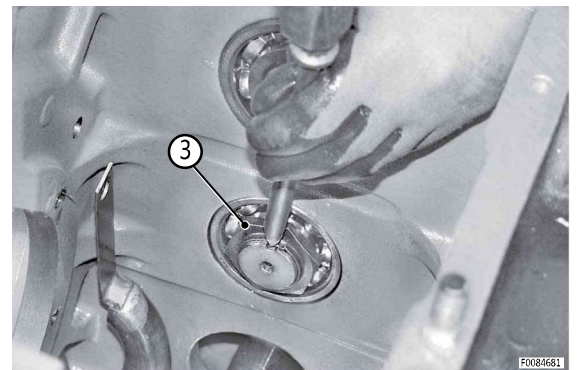

F0084681



Procedure 2

- Check the condition of O-ring (15) and renew it if necessary.
O-ring: Grease

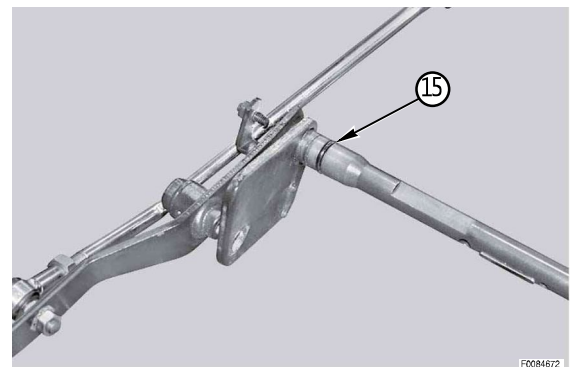

F0084672





Disassembly of the PTO output shaft - 4-speed version

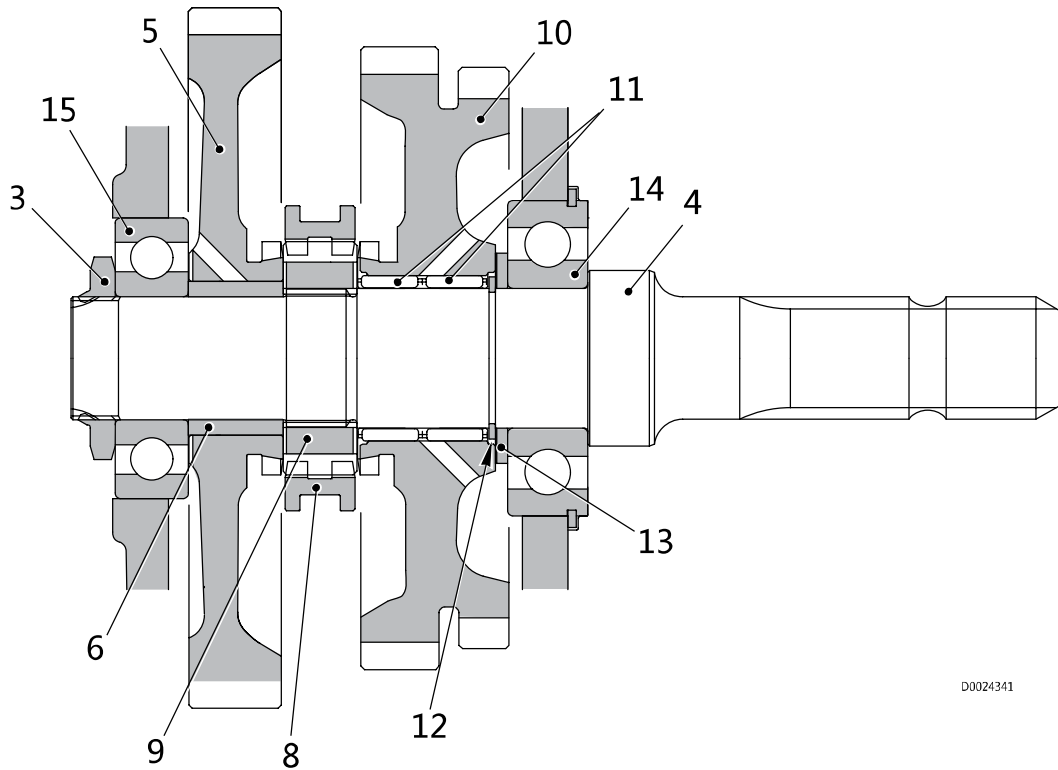

D0024341

Fig. PTO final shaft.

Disassembly

Remove grub screw (1).

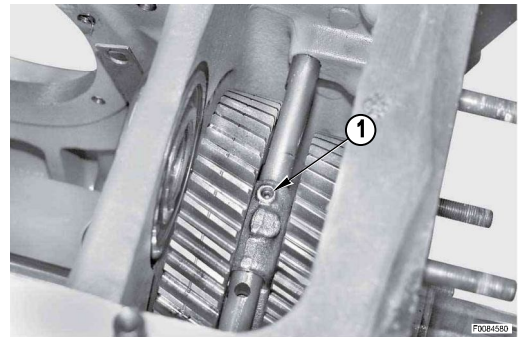

1.

Remove PTO speed selector rod (2).

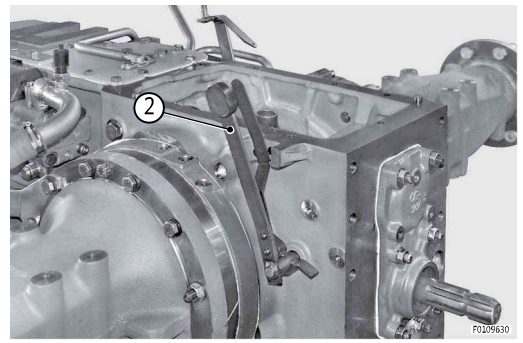

2.

Relieve the staking and remove ringnut (3) using a suitable wrench.

- o Renew the ringnut on reassembly.

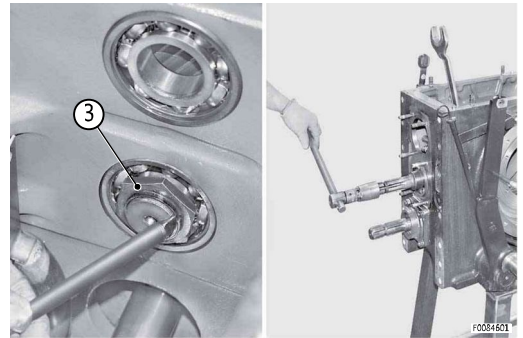

3.

Using a suitable tool, partially withdraw PTO output shaft (4).

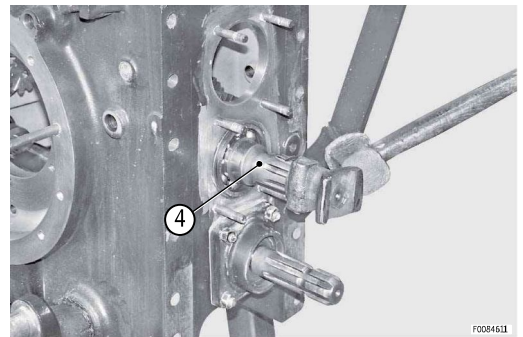

4.

Remove gear (5) complete with bush (6).

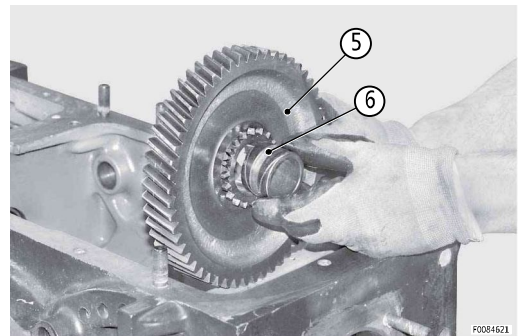

5.

Remove PTO speed selector fork (7).

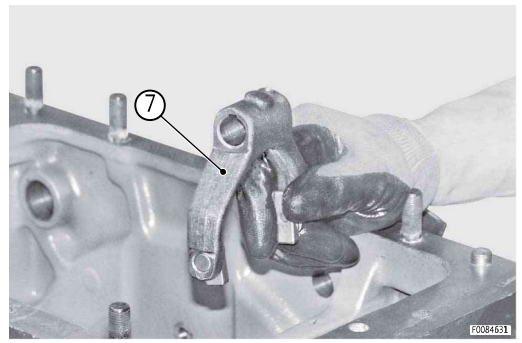

6.

Remove selector sleeve (8) and guide sleeve (9).

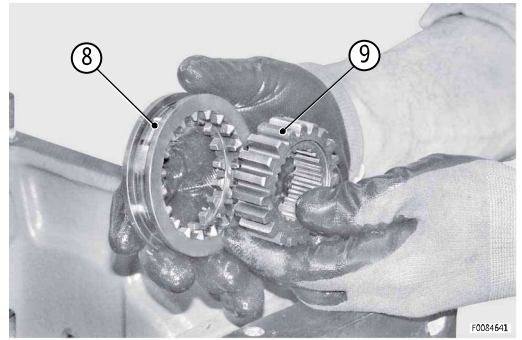

7.

Remove gear (10) complete with needle roller bearings (11) and remove shaft assy (4).

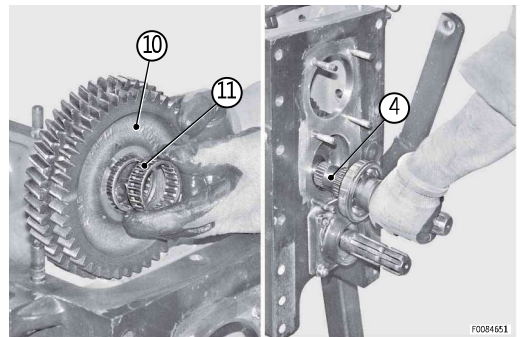

8.

Remove circlip (12) and, using a press, remove thrust washer (13) and bearing (14).

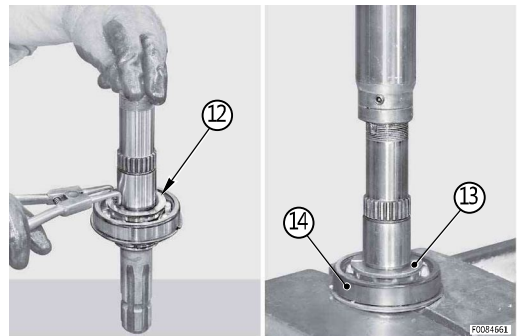

9.

Recover bearing (15).

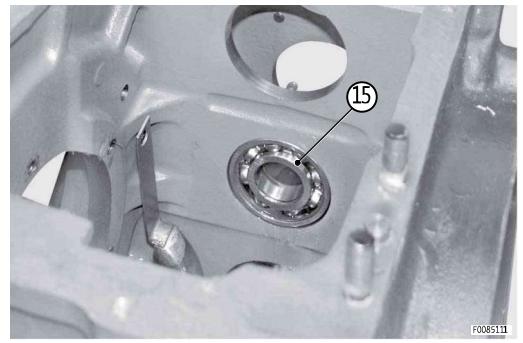

10.

Assembly

To assemble, follow the disassembly steps in reverse order and use caution in relation to the following procedures:

Procedure 9

- Take care to install bearing (14) the right way round relative to shaft (4).

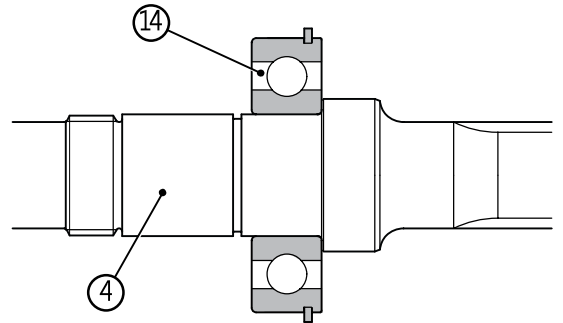

D0024353



Procedure 3

- Nut: 88 ± 1 Nm (64.9 ± 0.74 lb.ft.)
Stake ringnut (3).

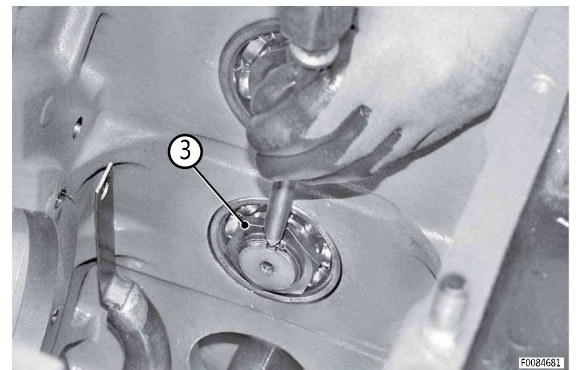

Procedure 2

- Check the condition of O-ring (16) and renew it if necessary.
O-ring: Grease

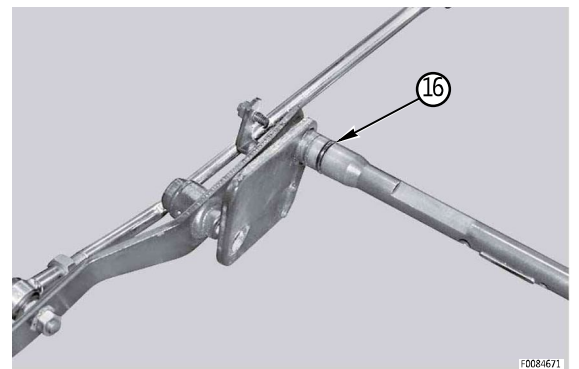

Thank you so much for reading.
Please click the “Buy Now!”
button below to download the
complete manual.



After you pay.

You can download the most
perfect and complete manual in
the world immediately.

Our support email:

ebooklibonline@outlook.com