



Fitting and removing counterweight drive system, checking (L3)

Readily available commercial tools:

- Torque wrench

Special tools:

- Alignment pins (q.ty 2): 100810
- Plaster
- DEUTZ DW 72 mastic

Removing counterweight drive system

- 3 - Mounting pin
- 4 - Gear wheel
- 5 - Self-tapping screw
- 6 - Washer
- 8 - Hex screw
- 9 - O-ring
- 11 - O-ring
- 12 - Mounting pin

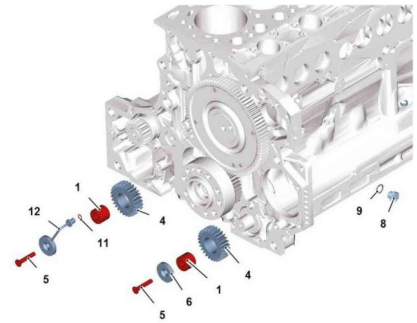

© 50330-0

1.

- Disassemble the gear case.



Construction unit

09

- Bring cylinder piston 1 to top dead centre.



Note

The mark (1) on the flange of the crankshaft must line up with the reference mark (2).

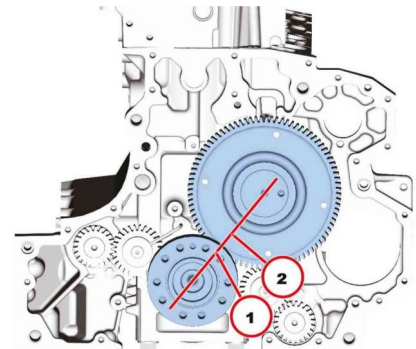

© 50305-0

2.

- Remove screw (1).
- Remove washer (2).
- Remove the intermediate wheel (3).
- Remove the bearing pin.

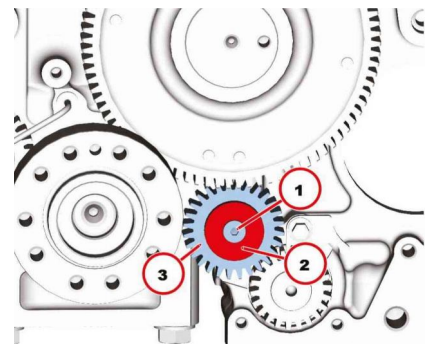

© 50306-0

3.

- Remove screw (1).
- Remove lube oil pipe (2).
- Remove the intermediate wheel (3).
- Remove the bearing pin.

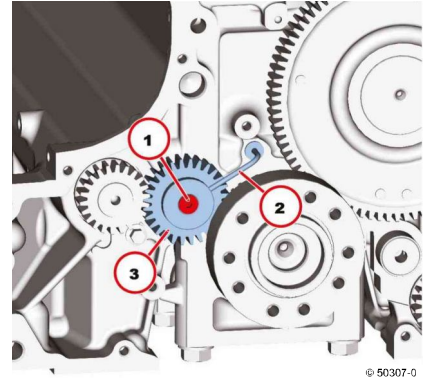

© 50307-0



4.

Fitting the counterweight drive system

- o Bring cylinder piston 1 to top dead centre.



Note

The mark (1) on the flange of the crankshaft must line up with the reference mark (2).

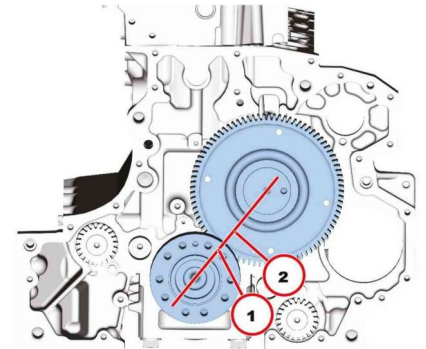

© 50305-1



1.

- o Do not fully unscrew drain plug (1).

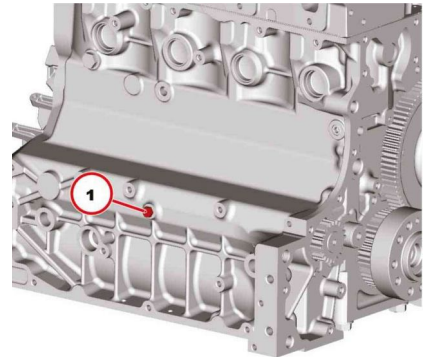

© 50309-0



2.

- o Insert the centring pins (1).
- o Fasten the mass compensation shaft with the centring pins (1).



WARNING

Stop rotating the mass compensation shaft.

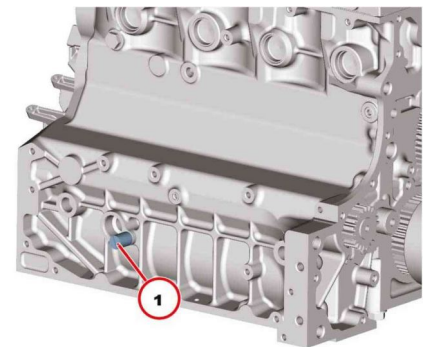

© 50311-0



3.

- o Apply the reference marks (1) and (2).

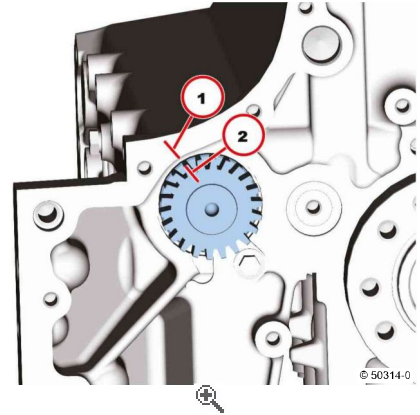

- 4.
- Unscrew the centring pins (side A).
 - Turn the mass compensation shaft of the two teeth in the direction of the arrow.

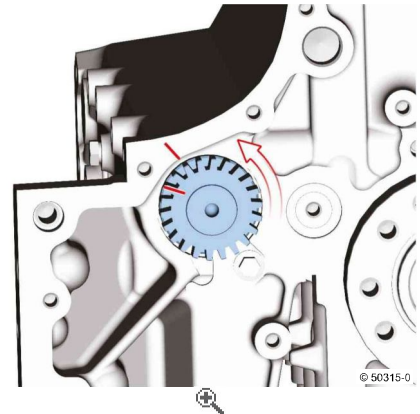

- 5.
- From above, engage the intermediate wheel (1) in the tothing.

Note

Turn the mass compensation shaft in the direction of the arrow until the reference marks coincide. Centre the intermediate wheel (1) with respect to the threaded hole (2).

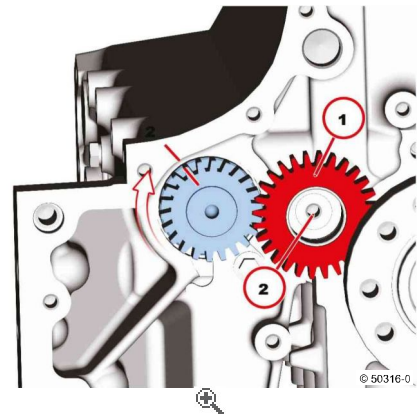

- 6.
- Lightly oil the bearing pins (1).
 - Insert the bearing pins (1).

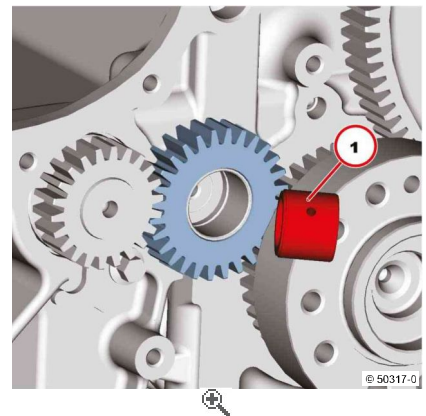

- 7.
- Fit new O-ring (1).

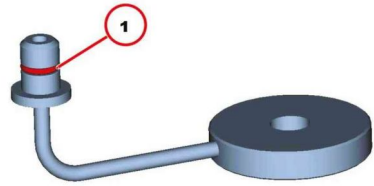

© 50318-0



8.

- Fit lube oil pipe (1).
- Tighten screws (2).



Note

Insert the screw with DEUTZ DW 72 sealant. Do not tighten the screw at this stage.

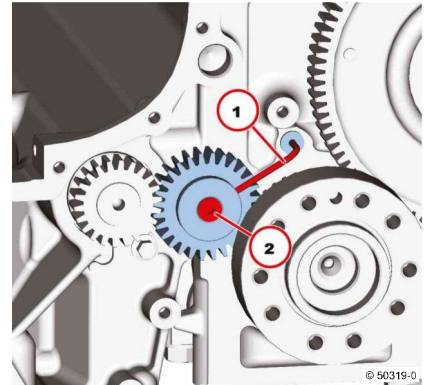

© 50319-0



9.

- Do not fully unscrew drain plug (1).

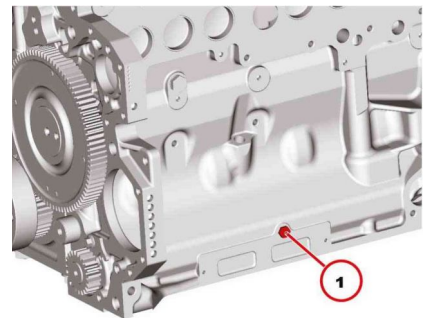

© 50308-0



10.

- Insert the centring pins (1).
- Fasten the mass compensation shaft with the centring pins (1).



WARNING

Stop rotating the mass compensation shaft.

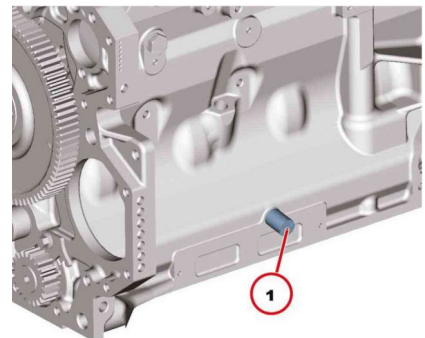

© 50310-0



11.

- Assemble the B side intermediate wheel.



Note

Centre the intermediate wheel (1) with respect to the threaded hole (2). If the sides of the teeth do not coincide with the crankshaft, it can be rotated easily.



WARNING

Stop rotating the mass compensation shaft.

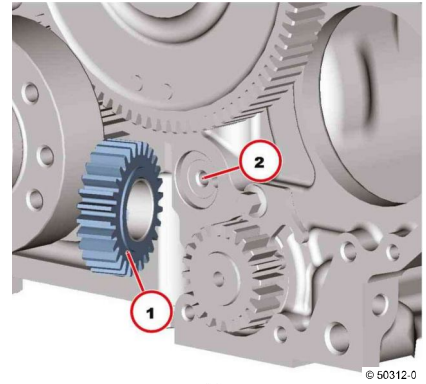

© 50312-0



12.

- Lightly oil the bearing pins (1).
- Insert the bearing pins (1).
- Fit washer (2).
- Screw in the screw (3).



Note

Insert the screw with DEUTZ DW 72 sealant. Do not tighten the screw at this stage.

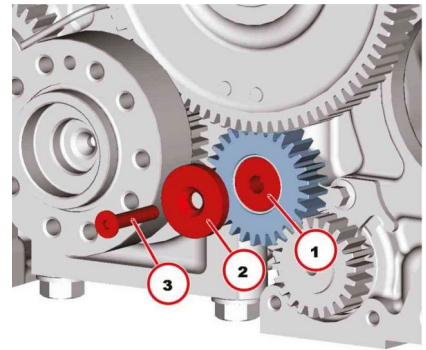

© 50313-0



13.

- Unscrew the centring pins (1).

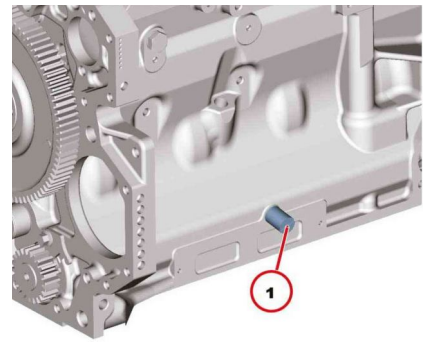

© 50316-0



14.

- Fit a new seal.
- Tighten the screw plug (1): 9 Nm

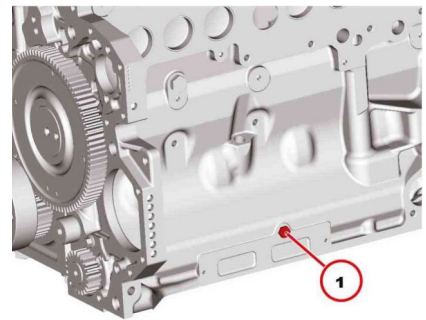

© 50308-0



15.

- Unscrew the centring pins (1).

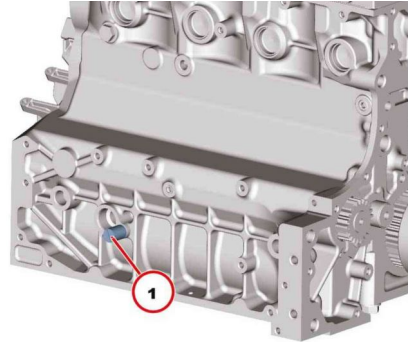

© 50311-0



16.

- Fit a new seal.
- Tighten the screw plug (1): 9 Nm

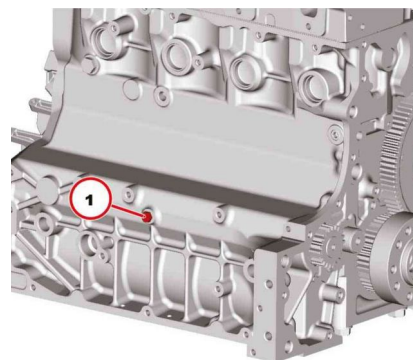

© 50309-0



17.

- Tighten the screws (1): 22 Nm
- Assemble the gear case.

	Construction unit 09
--	--------------------------------

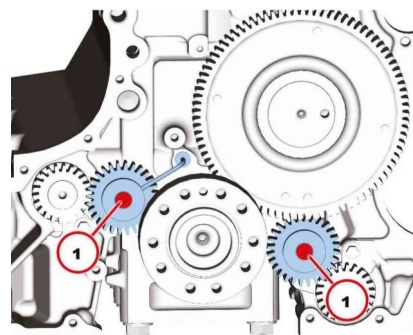

© 50320-0



18.

Technical data

Tightening torque

ID no.	Designation	Screws type	Indications/observations	Value
A72 001	Screw plug (counterweight shaft) on crankcase			9 Nm
A72 003	Intermediate wheel on crankcase		Fit with DEUTZ DW 72 2 sealant	22 Nm

	Note When tightening fasteners to the specified torque using a torque wrench, a torque dispersion of +/- 10 % is permitted.
--	---



Assembly and disassembly of the crankshaft (L3)

Disassembly of the crankshaft

- o 1 - Crankshaft
- o 5 - Threaded insert

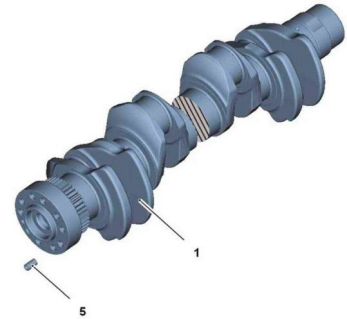

© 48779-0

1.

- o Disassemble the front cover.



Construction unit

01

- o Disassemble the gear case cover.



Construction unit

09

- o Disassemble the connecting rod drum.



Construction unit

06

- o Place the mark of reference (1) on the ring gear of the camshaft.



Note

The reference mark must be located on a line between the marking (2) and the mid point (3) of the camshaft.

2.

- o Uniformly rotate the crankshaft until the mark (1) on the flange of the shaft coincides with the auxiliary mark (2) on the camshaft ring gear.



Note

If the crankshaft flange is aligned, the mark on the camshaft ring gear will be covered.

- o Disassemble the crankshaft bearing covers.



Construction unit

01

- o Disassemble the crankshaft bearings.



Construction unit

05

3.

- o Remove the crankshaft.

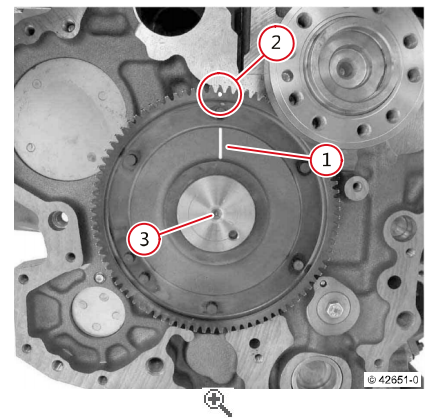

© 42651-0

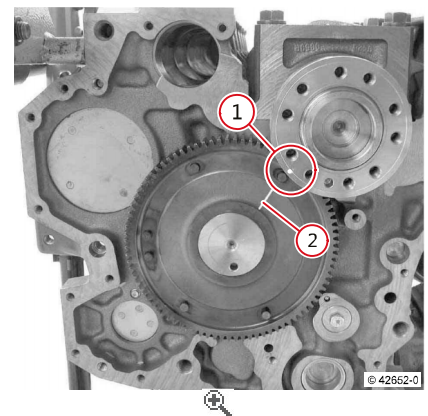

© 42652-0

Assembly of the crankshaft

- o Check the crankshaft endfloat.



Construction unit

05

- o Position the camshaft.

- o Assemble the crankshaft bearings.

 **Construction unit**
05

- o Oil the surfaces of the bearings.
- o Delicately insert the crankshaft in the crankcase.

 **Note**
The mark (1) on the flange of the crankshaft must line up with the reference mark (2).

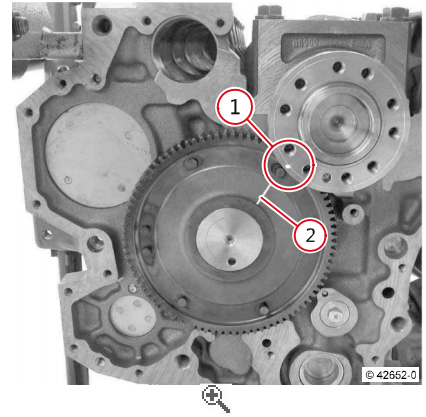

- 1.
2.
 - o Assemble the crankshaft bearing covers.

 **Construction unit**
01

- o Assemble the connecting rod drum.

 **Construction unit**
06

- o Assemble the gear case cover.

 **Construction unit**
09

- o Fitting the front cover.

 **Construction unit**
01



Crankshaft check (L3)

Readily available commercial tools:

- Magnetic stand for measurements
- Palmer
- Internal bore meter
- Prisms
- Hardness tester

Special tools:

- Dial gauge: 100400

Check the hardness of the main journal

- Apply the hardness tester on the bearing pins.

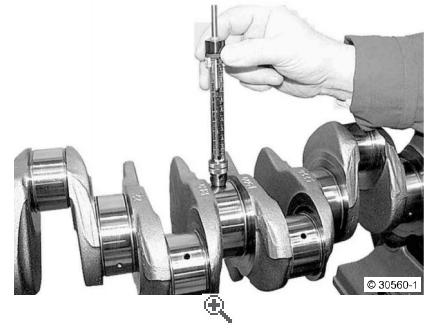

1.

- Lift (1) the probe and press the release device (2).



Note

The probe (1) falls downward, briefly hits the surface and goes up to the measurement value.

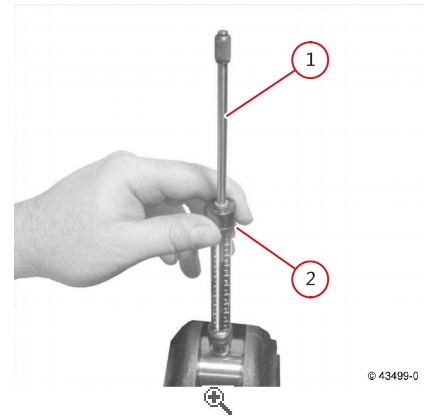

2.

- Read the value indicated (arrow) by the hardness tester.
- Nominal, minimum value: 55 HRC



Note

The measurement values must be converted using the tester table.

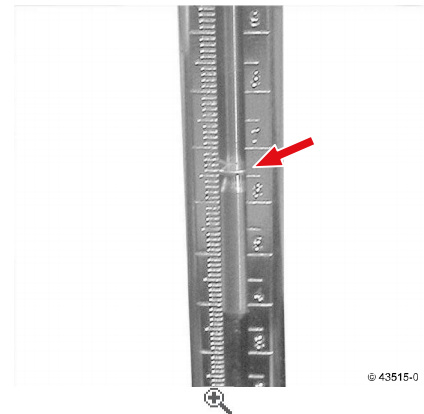

3.

Check the diameter of the main bearing pins



**Note**

Measurement diagram of the main journals on points 1 and 2 in surfaces a and b.

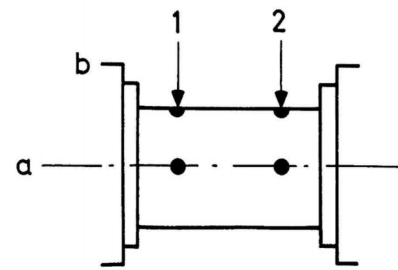

© 36424-2



1.

- Measure the main bearing pins with the palmer.
- Nominal value:
 - Standard: $84(+0,-0.02)$ mm
 - Degree of undersizing: 0.25 mm

**Note**

Measurement points, see diagram.

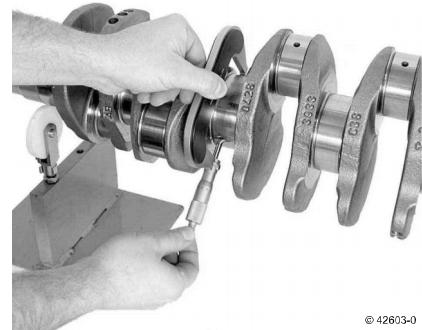

© 42603-0



2.

Check the diameter of the connecting rod pins

- Measure the main journal with the palmer.
- Nominal value:
 - $69,994(+0,-0.02)$ mm
 - Degree of undersizing: 0.25 mm

**Note**

Measurement points, see diagram.

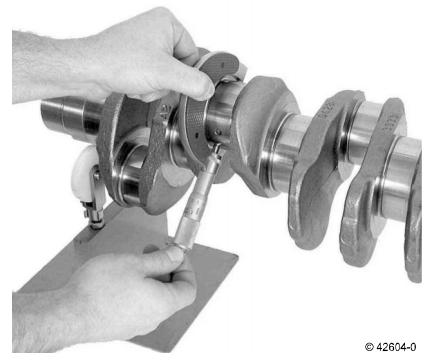

© 42604-0



1.

Check the coaxiality

- Rest the crankshaft on the prisms.
- Apply the magnetic stand for measurements.
- Fit the dial gauge
- Apply the preloaded probe on the main bearing pins (arrow) and adjust the dial gauge to "0".
- Uniformly turn the crankshaft and check the coaxiality.
 - Nominal value: 0.1 mm
- Remove the magnetic stand for measurements.
- Disassemble the dial gauge.

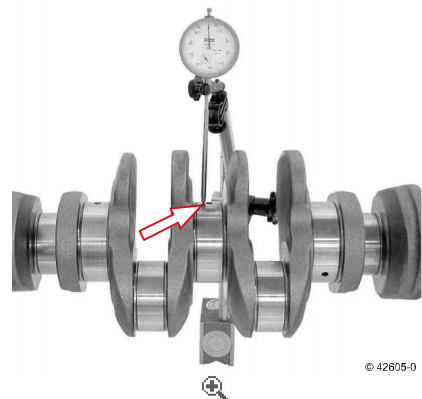

© 42605-0



1.

Measuring the length of the flanged bearing

- Adjust the palmer to 32 mm.

Thank you so much for reading.
Please click the “Buy Now!”
button below to download the
complete manual.



After you pay.

You can download the most
perfect and complete manual in
the world immediately.

Our support email:

ebooklibonline@outlook.com