



Hydraulic reverse shuttle unit

Removing the unit

Place the shuttle unit (1) on the mount T1 (Part No. 5.9030.xxx.x) and remove the 7 screws (2).

- Mark the flange (3) and the mount to facilitate subsequent reassembly.

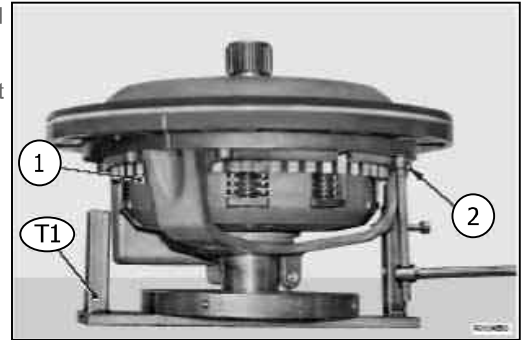

1.

Remove the complete flange (3).



2.

Remove the 10 screws (4).

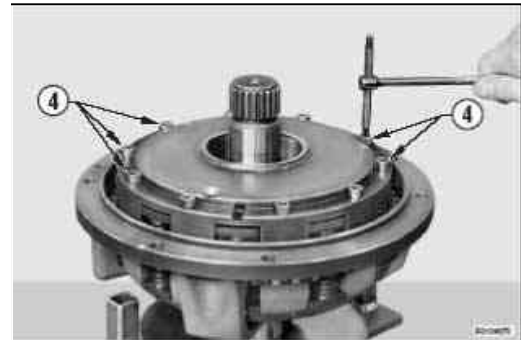

3.

Remove the forward drive clutch unit (5).



4.

Retrieve the springs (7) and the pins (8) from the reverse drive clutch unit (6).

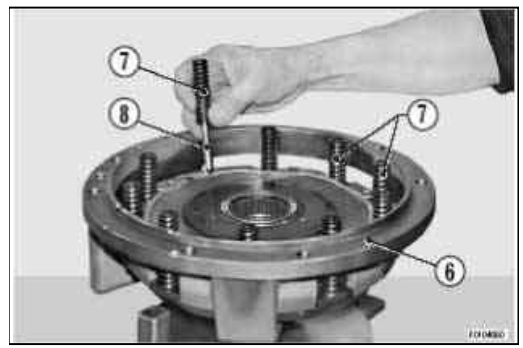

5.

Remove the O-rings (9).

- o Replace the O-rings at every disassembly.

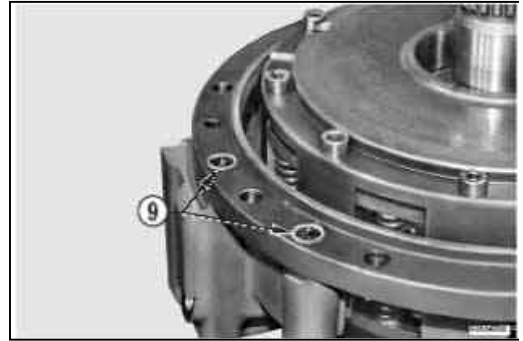

6.



Clutch assembly: Forward Drive

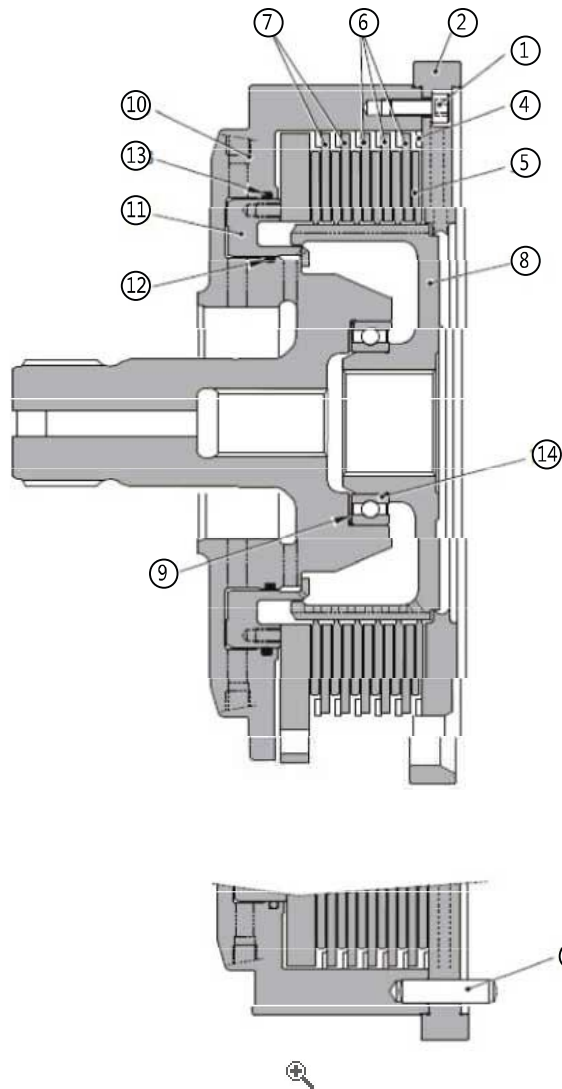

Shuttle unit / Clutch assembly

Removal

Remove the 2 screws (1) and remove the plate (2).

- o Mark the installation hole for the pin (3).

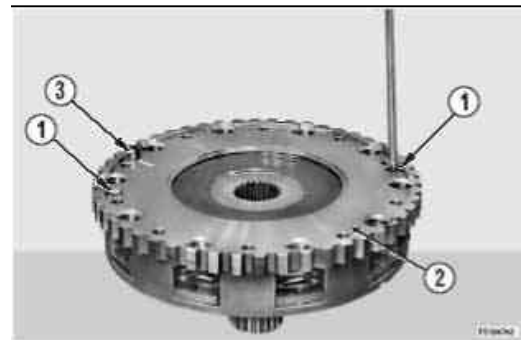

1.

Remove the complete clutch pack, comprising six corrugated springs (4), six friction discs (5), five steel discs (6) measuring 3 mm in thickness and one steel disc (7) measuring 6.5 mm in thickness

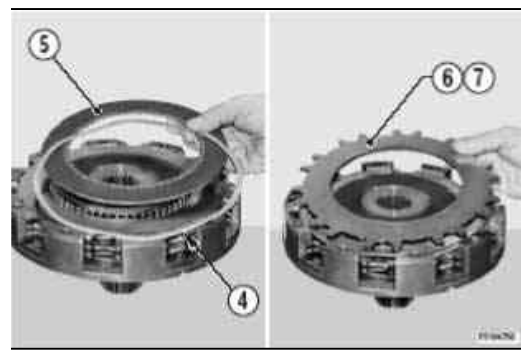

2.

Remove the hub (8) and retrieve the Belleville washer (9).

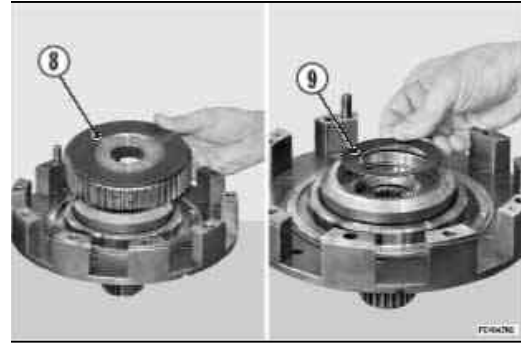

3.

Blow compressed air at low pressure through the hole "A" in the clutch housing (10) to expel the piston (11).

- o Restrain piston (11) as it could be expelled at high speed and be damaged.

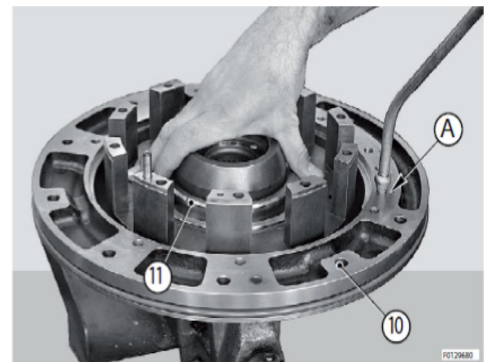

4.

Check the condition of O-rings (12) and (13) and replace if necessary.



5.



note
Only if necessary

Remove the bearing (14) from the hub (8).

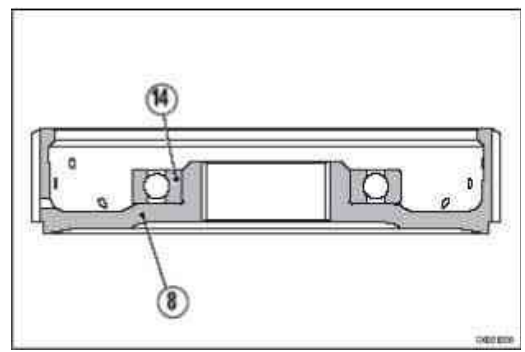

6.

Assembly

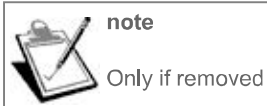

note

Only if removed

Using a suitable presser tool, install the bearing (14) on the hub (8).

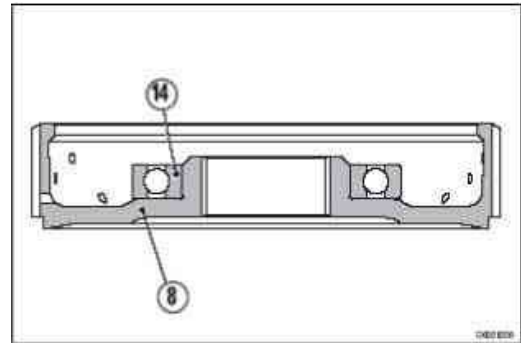

1.

Fit the O-rings (12) and (13) in the clutch housing (10).

- o To facilitate installation of O-ring (13), stretch it slightly at several points around their circumference so that the entire circumference is held in place in the respective seat. O-ring: hydraulic oil.

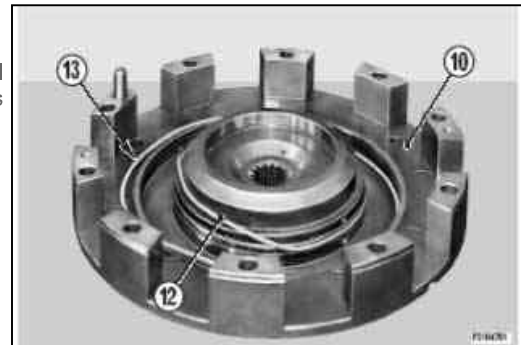

2.

Fit the piston (11) in the clutch housing (10), ensuring that it is installed fully in its seat.

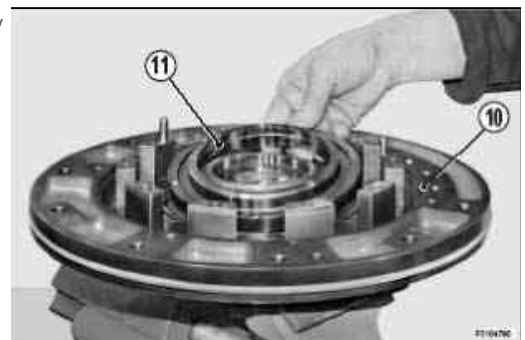

3.

Fit the Belleville washer (9) in the clutch housing.

- o Ensure that the Belleville washer (9) is oriented correctly.

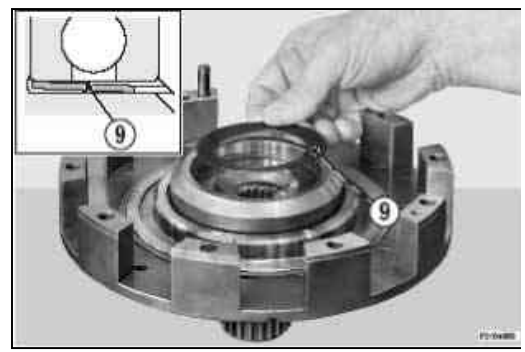

4.

Mount the hub (8) and ensure that the bearing (14) is fully installed onto the Belleville washer (9).

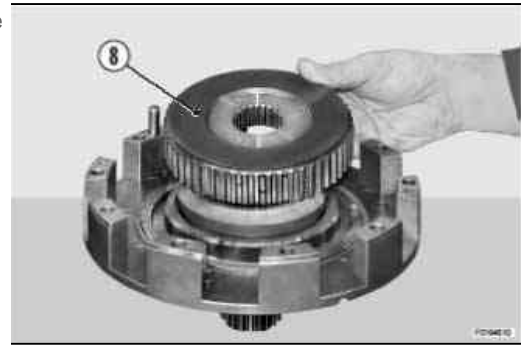

5.

Fit the first steel disc (7), the friction disc (5) and the corrugated spring (4).

- o Ensure that the 6.5 mm thick steel disc (7) is installed as the first disc. Friction disc (hydraulic oil)

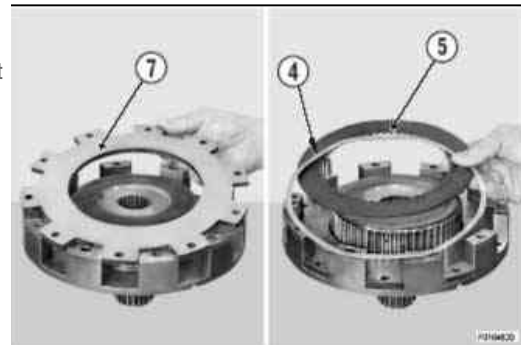

6.

Complete assembly of the clutch pack, installing the discs in the following sequence: one steel disc (6), one friction disc (5) and one corrugated spring (4). Friction discs: Hydraulic oil

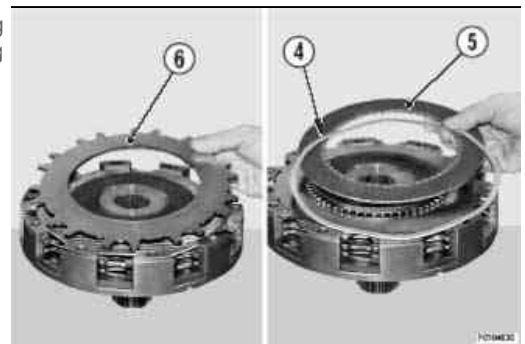

7.

Fit the plate (2) and fasten in place with the screws (1). Position the plate correctly so that the pin (3) installs in the hole marked during disassembly.

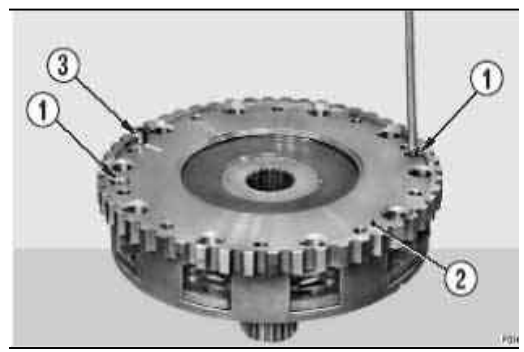

8.

T.Y65.01.D0.03.02.00.01 - v1



Clutch assembly: Reverse

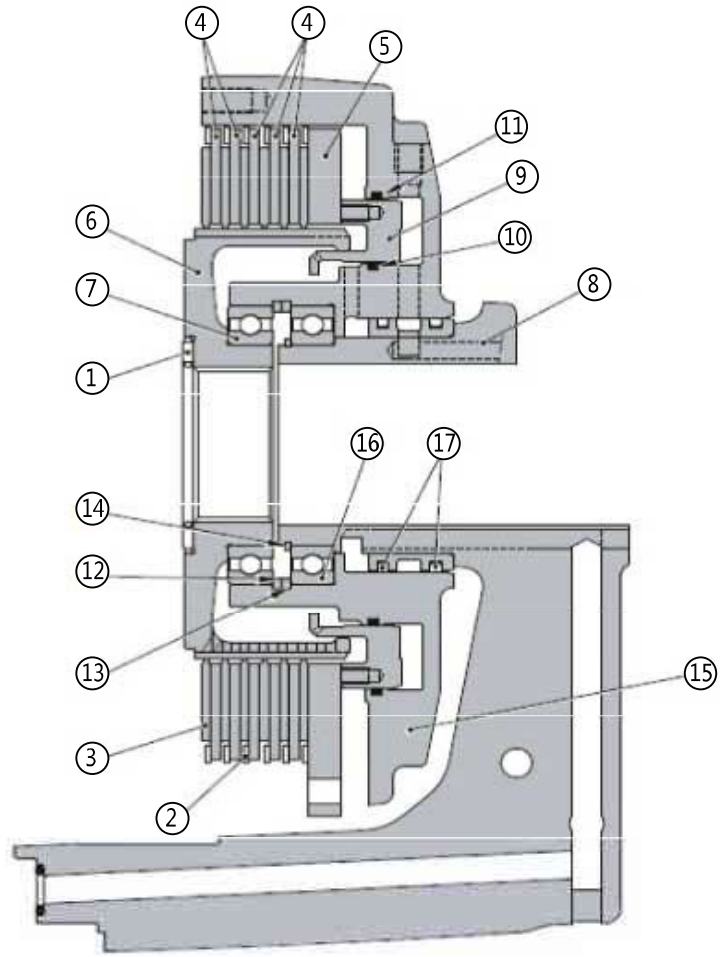

Shuttle unit / Clutch assembly

Removal

Remove roller cage (1).



1.

Remove the complete clutch pack, comprising six corrugated springs (2), six friction discs (3), five steel discs (4) measuring 3 mm in thickness and one steel disc (5) measuring 6.5 mm in thickness

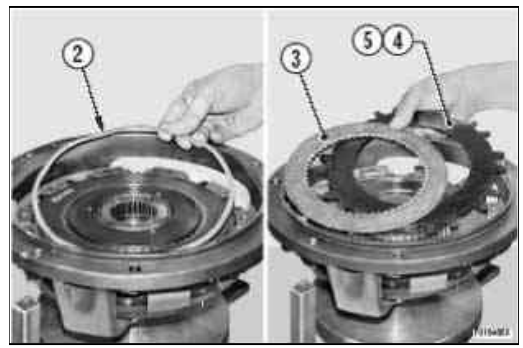

2.

Remove the hub (6)

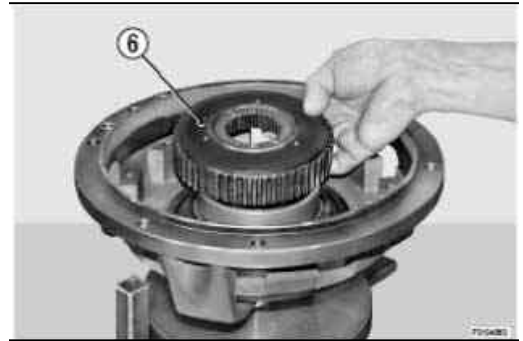

3.

 **note**
Only if necessary

Using three screws as a presser tool, remove the bearing (7) from the hub (6).

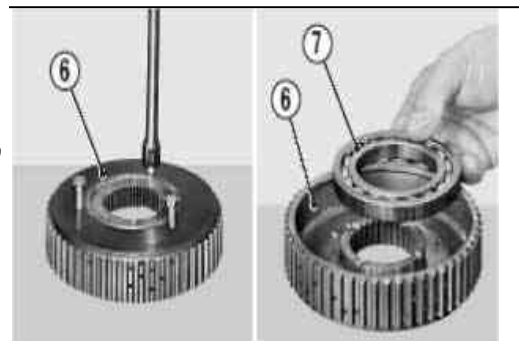

4.

Blow compressed air at low pressure through the hole "A" in the mount (8) to expel the piston (9).

- o Restrain piston (9) as it could be expelled at high speed and be damaged.

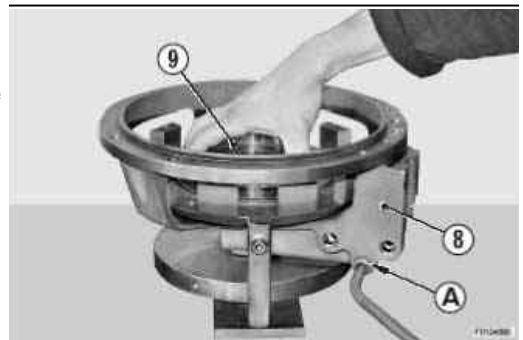

5.

Check the condition of the O-rings (10) and (11) and replace if necessary.

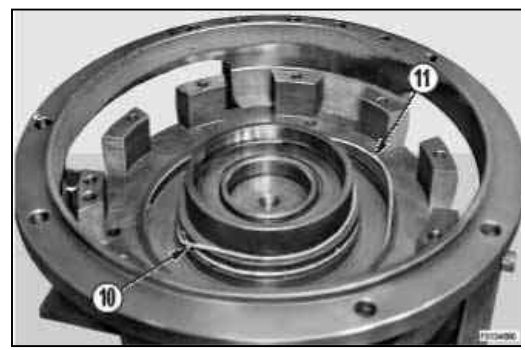

6.

Remove circlip (12) and remove spacer (13).

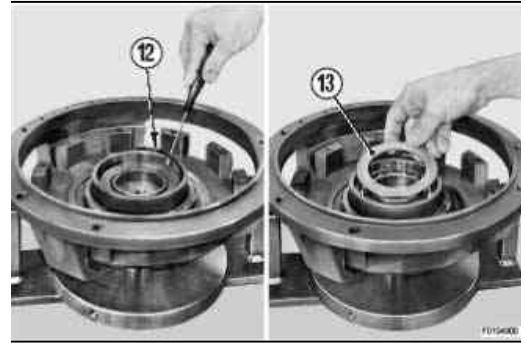

7.

Remove circlip (14).



8.

Remove the clutch housing (15) from the support (8).

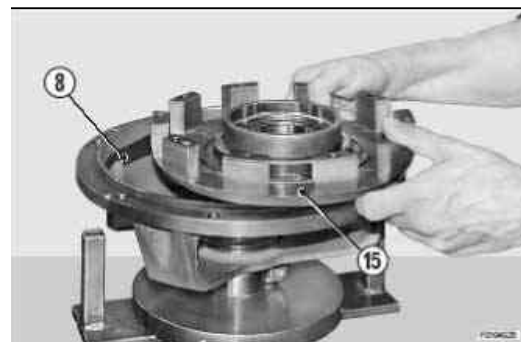

9.

Remove the bearing (16) from the clutch housing (15).

Thank you so much for reading.
Please click the “Buy Now!”
button below to download the
complete manual.



After you pay.

You can download the most
perfect and complete manual in
the world immediately.

Our support email:

ebooklibonline@outlook.com