



## Removal and refitting of the flywheel (fixing elements)

Special tools:

- Guide pin (shop-made tool)
- M10x120 auxiliary screws
- Rotation angle gauge 01899093

### Removal of the flywheel

- 1 – Flywheel
- 2 – Ring gear
- 3 – Screw
- 4 - Bearing bush

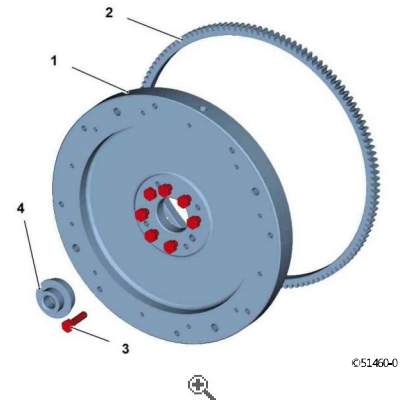

1.

- Hold the crankshaft from the central screw.
- Fit service screws (1).
- Remove screws (2).
- Remove the flywheel using the service screws.
- Carry out a visual inspection of the components.

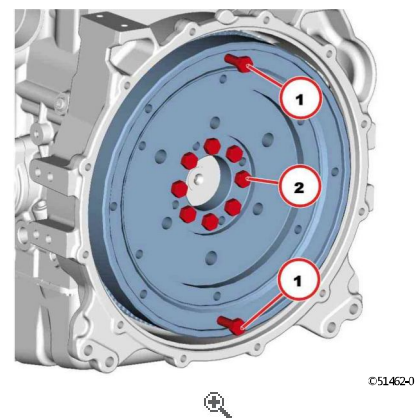

2.

### Refitting the flywheel

- Insert the shop-made guide pin



#### NOTE

The holes in the flywheel must coincide with the threaded hole in the V-belt pulley.

- Fit the flywheel using the service screws.

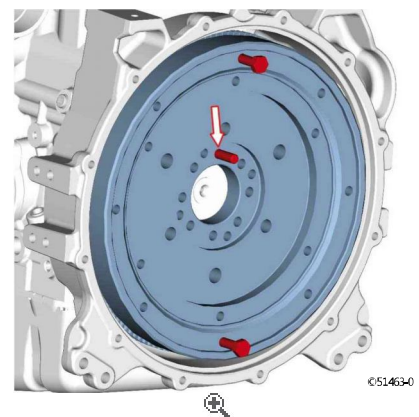

1.



#### WARNING

The screws must be renewed after being removed.

- Tighten the screws in alternate sequence.
  - Stage 1: 30 Nm.
- Tighten the screws using the rotation angle gauge.
  - Stage 2: 60°

- Stage 3: 30°
- Withdraw locating dowel "A".
- Unscrew the service screws.

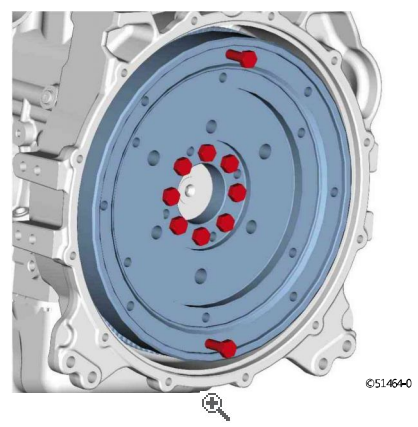

2.

## Technical data

### Tightening torque

ID no.	Designation	Screws type	Indications/observations	Value
A05 001	Flywheel to engine block		Stage 1: Use new screws	30 Nm
A05 001	Flywheel to engine block		Stage 2:	60°
A05 001	Flywheel to engine block		Stage 3:	30°



#### NOTE

When tightening fasteners to the specified torque using a torque wrench, a torque dispersion of +/- 10 % is permitted.



## Removal and refitting of the cylinder head cover

### Removal of the cylinder head cover

- 1 - Cylinder head cover
- 2 - Gasket
- 3 - Screw
- 4 - Closing plug
- 5 - Connector

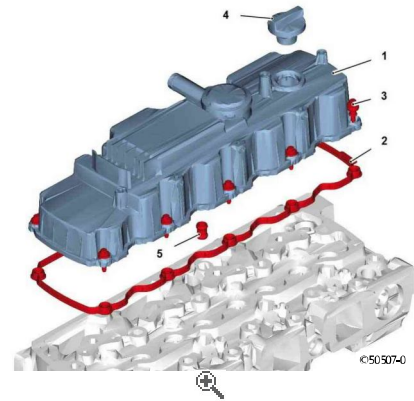

1.

- Remove the crankcase breather.



- Remove screws (1).
- Remove cylinder head cover (2).

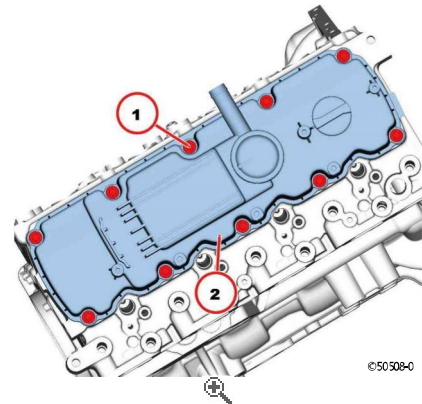

2.

- Remove seal (1).

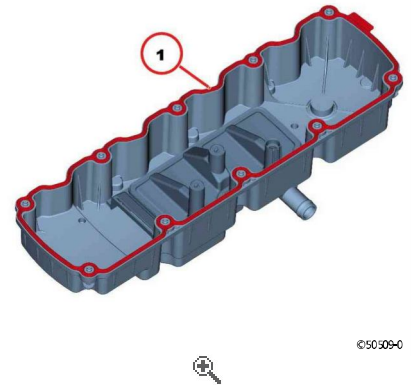

3.

### Refitting the cylinder head cover

- Fit the new gasket (1).

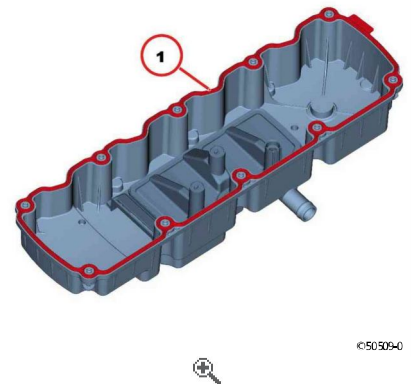

1.

- o Fit cylinder head cover (1).

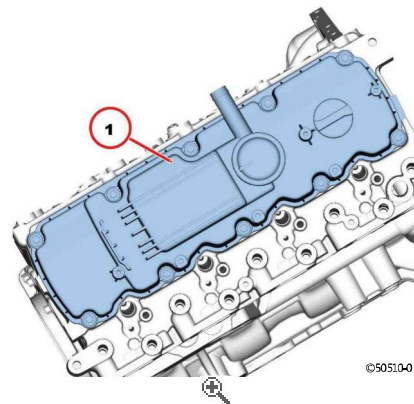

©50510-0

2.

- o Tighten the screws in the sequence indicated: 8.5 Nm
- o Fit the crankcase breather.



**Construction unit**  
01

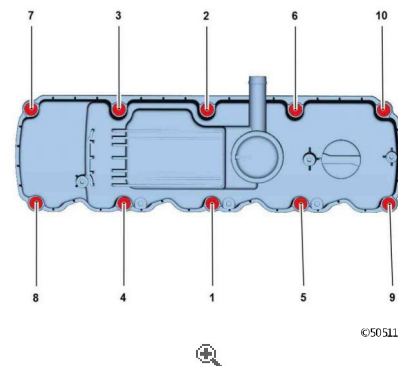

©50511-0

3.

### Technical data

#### Tightening torque

ID no.	Designation	Screws type	Indications/observations	Value
A08 004	Cylinder head cover to cylinder head			8.5 Nm



**NOTE**  
When tightening fasteners to the specified torque using a torque wrench, a torque dispersion of +/- 10 % is permitted.



## Support

### WARNING



Ensure maximum cleanliness during all work. Before proceeding with removal, remove any paint residue or debris. Thoroughly clean the area around the components to be worked on. Dry any wet areas with an air jet. All fuel lines and unions should be closed immediately after opening using new, clean plugs or caps. Remove plugs and caps only immediately prior to assembly.

- o 1 – Mount
- o 2 - Speed sensor
- o 3 - Hex screw: 8,5 Nm
- o 4 - Hex screw: 5 Nm
  - Position 2:



### NOTE

Use a new O-ring.

1.

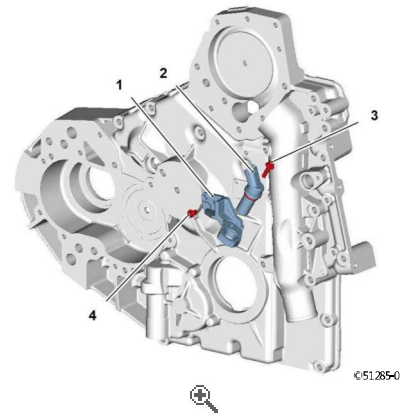



## Intermediate gear

- 1 - Intermediate gear
- 2 - Shaft
- 3 - Hex screw: 30 Nm

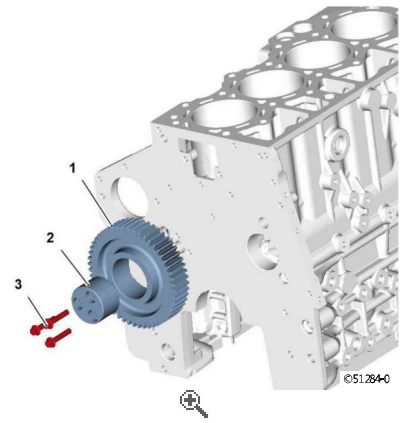

1.

T.\$93.21.B0.04.04.00.02 - v1



## Removal and refitting of the oil cooler



### NOTE

Collect auxiliary materials in suitable containers and dispose of them in compliance with the applicable regulations. The engine oil should be drained and replenished following the instructions given in the operation manual.

### Removal of the oil cooler

- 1 - Lubricant oil radiator
- 2 - Gasket
- 3 - Hex screw

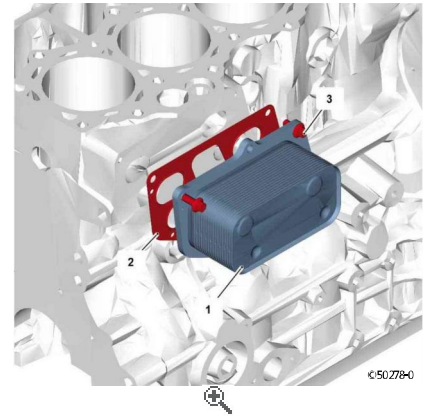

1.

- Remove all the screws (1).
- Remove oil cooler (2).
- Remove seal (3).



### NOTE

Collect used lubricating oil and dispose of it in accordance with the applicable regulations.

- Carry out a visual inspection of the components.

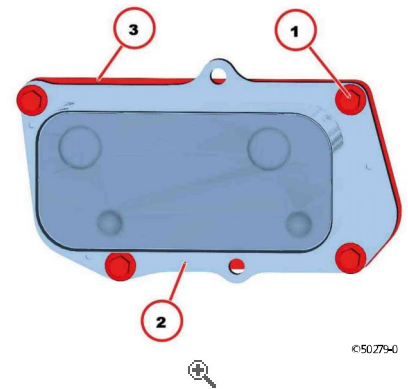

2.

### Refitting the oil cooler

- Carry out a visual inspection of the components.
- Clean the mating surfaces.
- Tighten the screws (arrowed).
  - M8x20-10.9
- Fasten the new gasket (1) to the oil cooler with the screws.

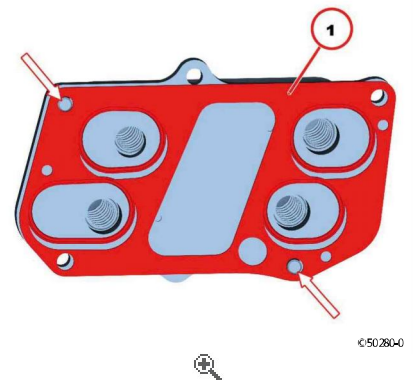

1.

- Fit the lubricant oil cooler (1).
- Tighten screws (2).
- Tighten all screws (2) alternately: 30 Nm

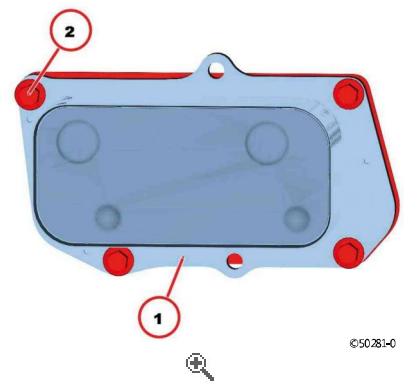

2.

**Technical data**

**Tightening torque**

ID no.	Designation	Screws type	Indications/observations	Value
A15 051	Oil cooler housing in correspondence of the crankcase			30 Nm



**NOTE**

When tightening fasteners to the specified torque using a torque wrench, a torque dispersion of +/- 10 % is permitted.





## Lubricating oil filter console

### NOTE



Collect operating materials in suitable containers and dispose of them in compliance with the applicable regulations. To drain and replenish the engine fluids and lubricants, follow the instructions provided.

- o 1 - Replacement filter: 12 Nm
- o 2 - Threaded bush
- o 3 - Cover
- o 4 - O-ring
- o 5 - Hex screw: 30 Nm



### NOTE

Use a new O-ring.

1.

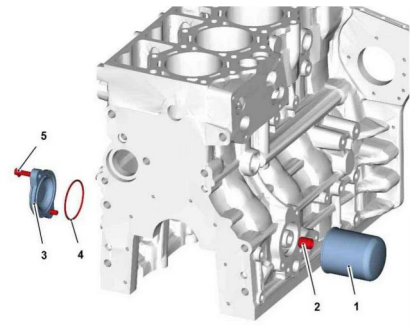

©50390-0



T.\$93.21.B0.06.01.00.01 - v1



## Removal and refitting of the oil pickup pipe

- DEUTZ DW 73 sealant

### Removal of the oil pickup pipe

- 1 - Oil intake pipe
- 2 - Torx screw
- 291 - Sealant

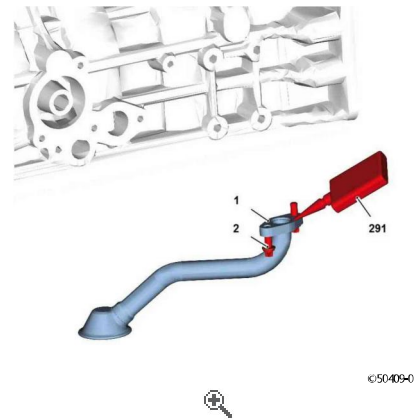

1.

- Remove the oil sump pan.



#### Construction unit

02

- Remove screws (1).
- Remove oil pickup pipe (2).
- Carry out a visual inspection of the component.

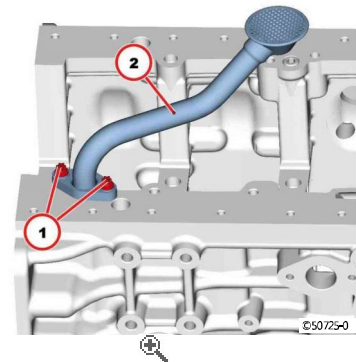

2.

### Refitting the oil pickup pipe

- Clean the sealing surface.
- Apply sealant (1) evenly to the mating surface.

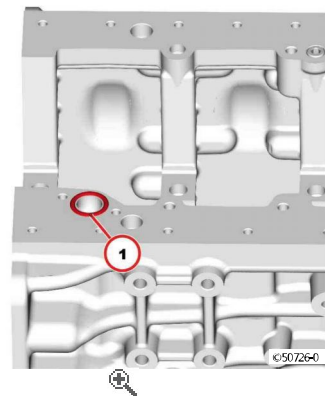

1.

- Clean the sealing surface.
- Fit the oil pickup pipe (1).
- Tighten the screws (2): 22 Nm
- Fit the oil sump pan.



#### Construction unit

02

Thank you so much for reading.  
Please click the “Buy Now!”  
button below to download the  
complete manual.



After you pay.

You can download the most  
perfect and complete manual in  
the world immediately.

Our support email:

[ebooklibonline@outlook.com](mailto:ebooklibonline@outlook.com)