



Gearbox and shuttle assembly - complete unit - Version with HML

Removal



DANGER

1. Disconnect the lead from the battery negative terminal (-) and apply the parking brake.

Disconnect the three pipes (2) from block (1) and remove them.

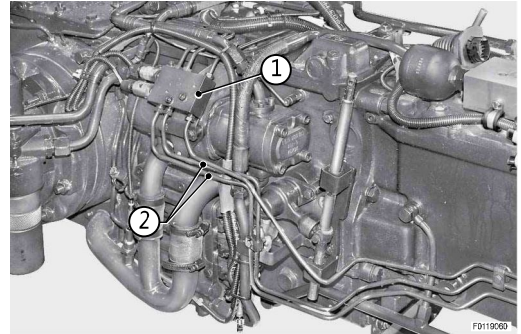

- 2.

Loosen union (3).

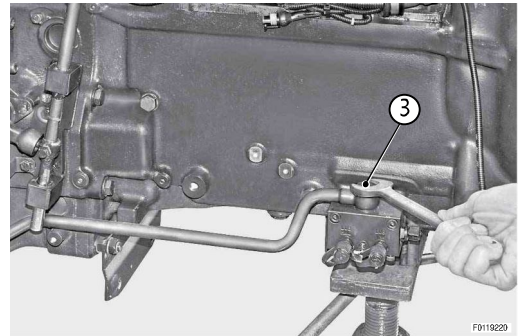

- 3.

Loosen union (4), remove screw (5).

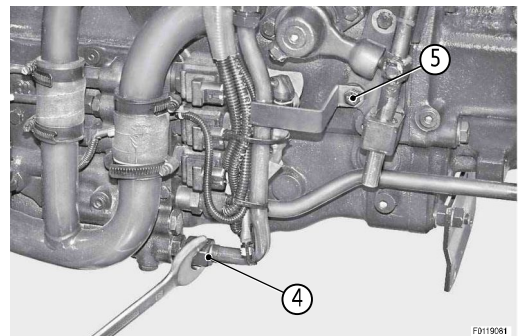

- 4.

Loosen union (6) and remove pipe (7).

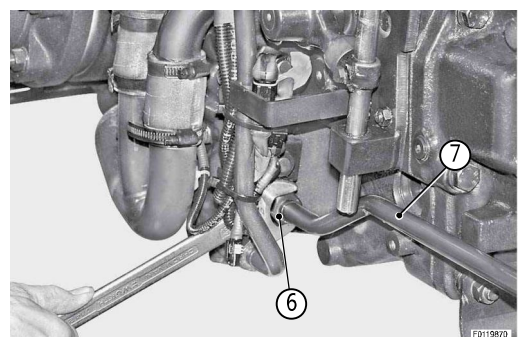

5.

Disconnect connectors (8) and move pipe (9).

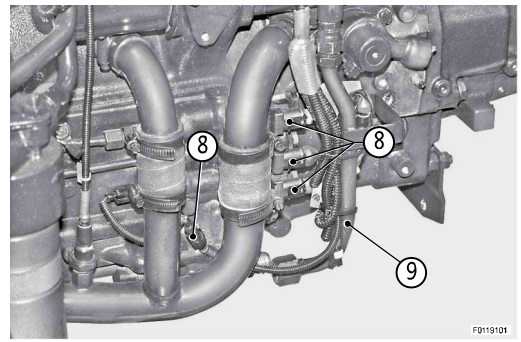

6.

Remove nuts (10) and remove lever (11).

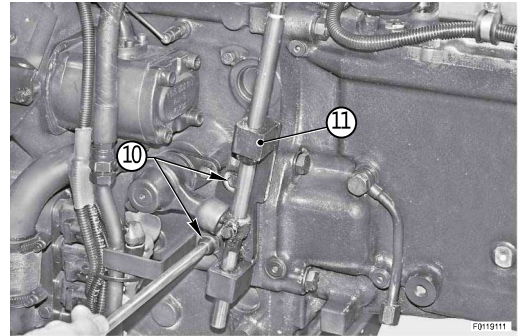

7.

Remove pin (12).

- o Renew the copper washers on reassembly.

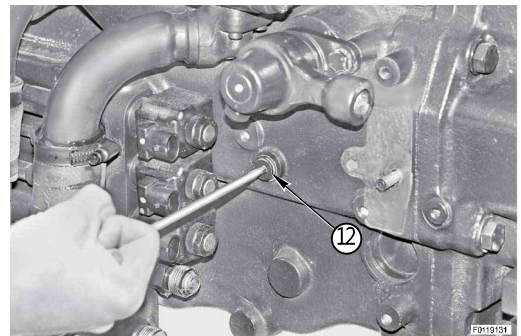

8.

Remove screw (13) and remove pipe (14).

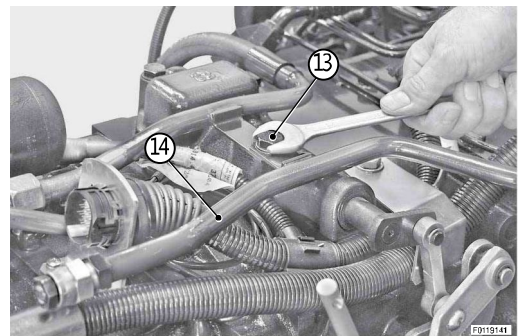

9.

Remove screws (15) and disconnect handbrake (16).

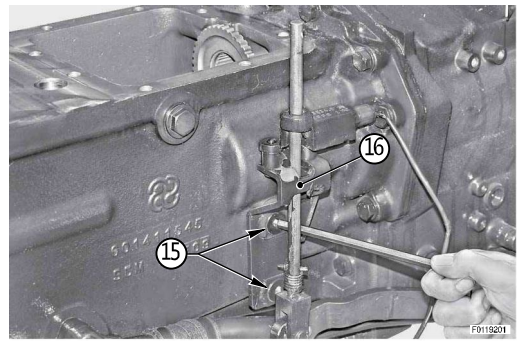

10.

Loosen clamps (17) and slide sleeve (18) onto pipe (19).

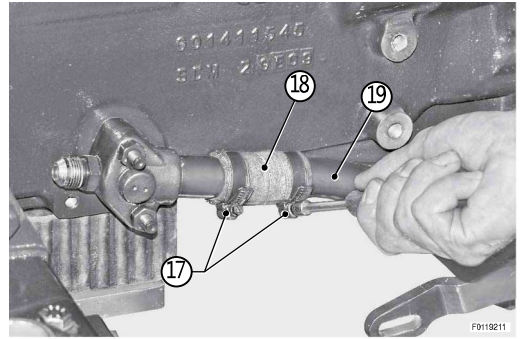

11.

Remove circlip (20) from 4WD crankshaft (21) at transmission output.

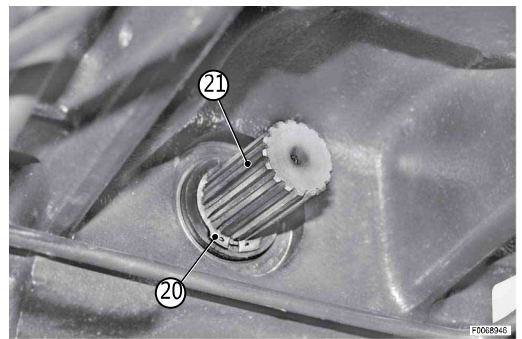

12.

Position a trolley jack "A" under the clutch housing and two stands "B" and "C" under the transmission.

Drive two wedges "D" between the front support and axle to prevent the engine from tipping when it is moved.

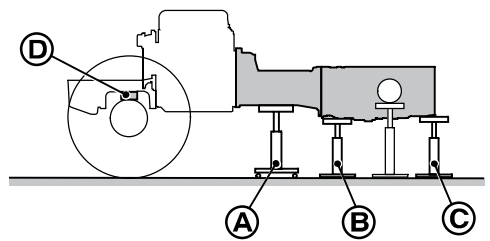

D0020800



13.

Remove the ten screws (22) and the two nuts (23).

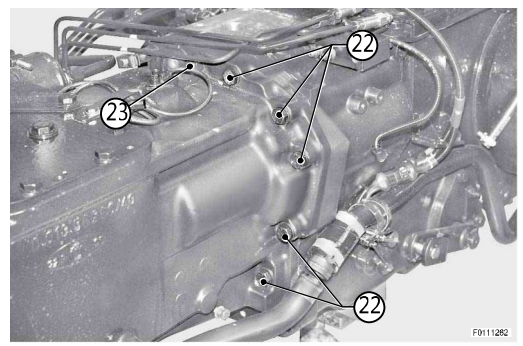

14.

Apply force to both front wheels to move the gearbox away from the transmission.

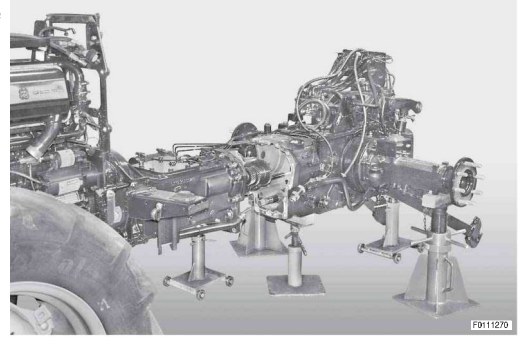

15.

Reassembly

Connect transmission and engine by performing the separation steps in reverse order.

Procedure 16

- Screws and nuts: 78 ± 4 Nm (57.5 ± 3.0 lb.ft.)
Mating face: Loctite 510

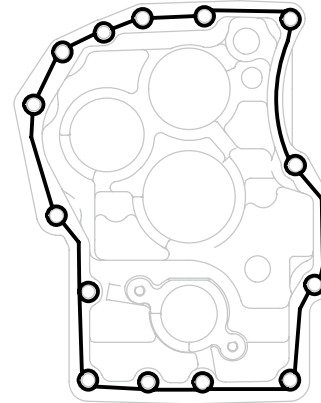



Disassembly of gearbox and shuttle assy. - complete unit - Version with HML

Disassembly

1. Position the gearbox and shuttle assembly vertically on a flat surface.

Remove shaft assembly (13).

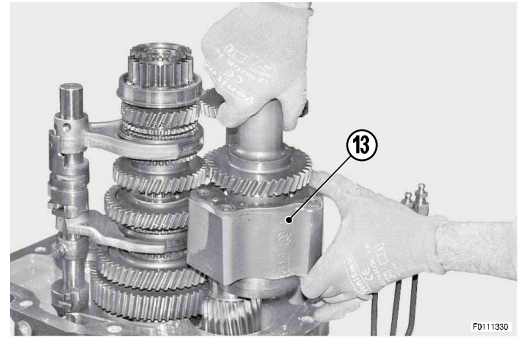

2.

Remove main shaft (15).

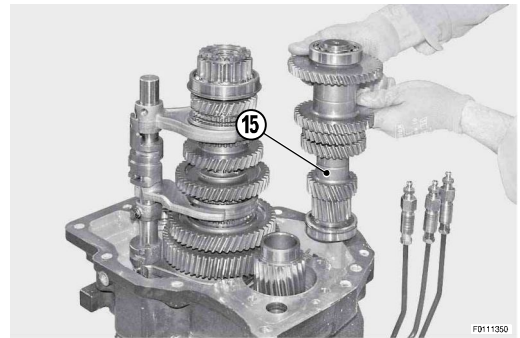

3.

Remove secondary shaft (16) and speed selector rod (17).

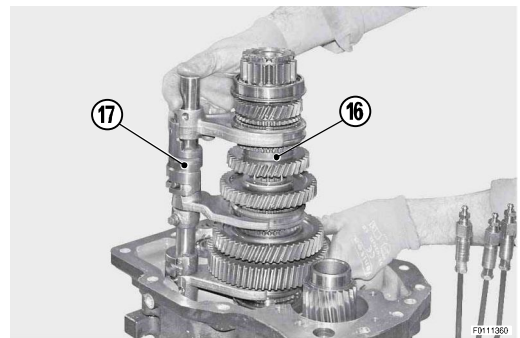

4.

Remove gear (18).

- o Take care as pulse wheel (19) will fall as soon as gear (18) is removed.

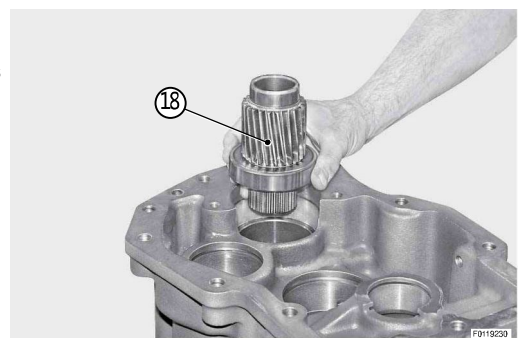

5.

Assembly

Refitting is the reverse of removal.

T.F18.26.D0.09.00.00.01 - v1



Gearbox and shuttle assembly - complete unit - Version without HML

Removal



DANGER

1. Disconnect the lead from the battery negative terminal (-) and apply the parking brake.

Disconnect the three pipes (2) from block (1) and remove them.

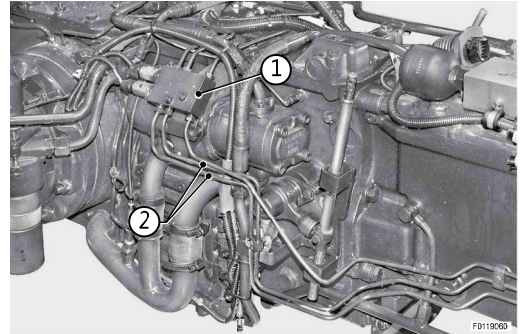

- 2.

Loosen unions (3) and (4).

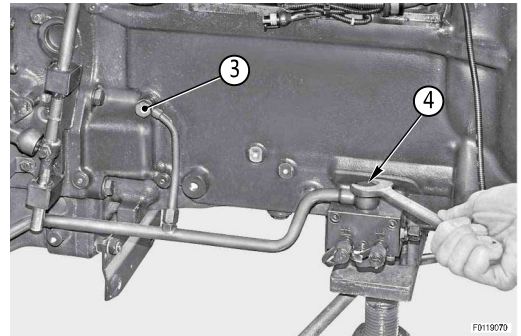

- 3.

Loosen union (5), remove screw (6).

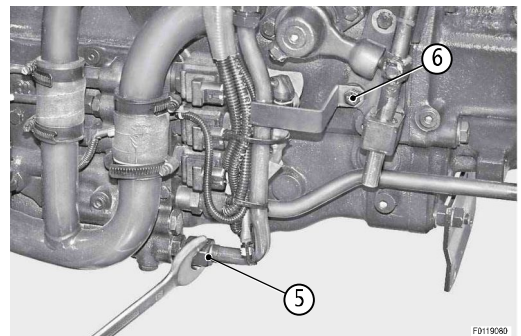

- 4.

Loosen union (7) and remove pipe (8).

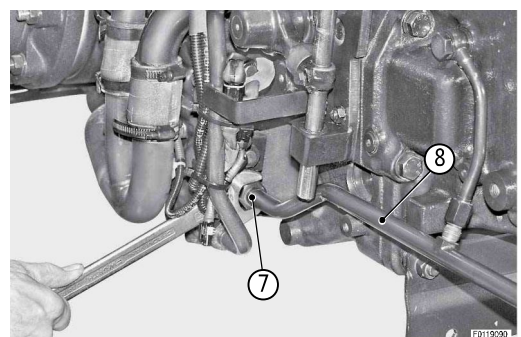

5.

Disconnect connectors (9) and move pipe (10).

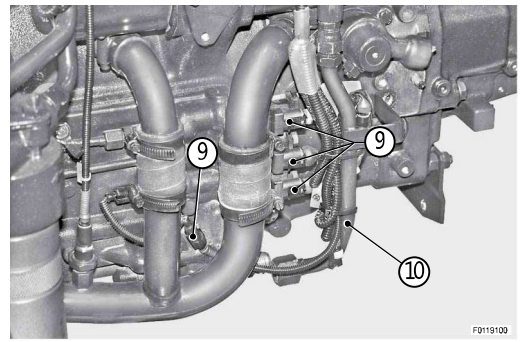

6.

Remove nuts (11) and remove lever (12).

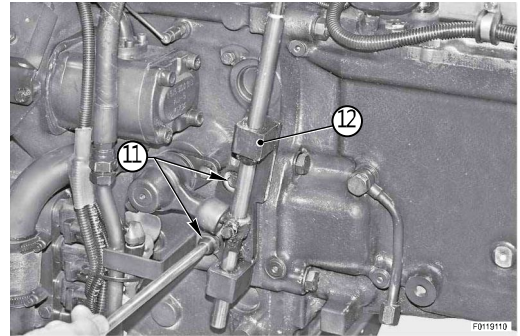

7.

Remove sensor (14) and unplug connector (13).

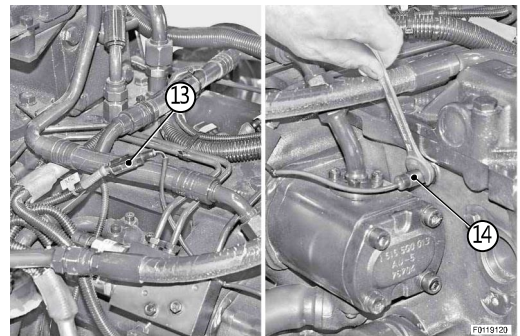

8.

Remove pin (15).

- o Renew the copper washers on reassembly.

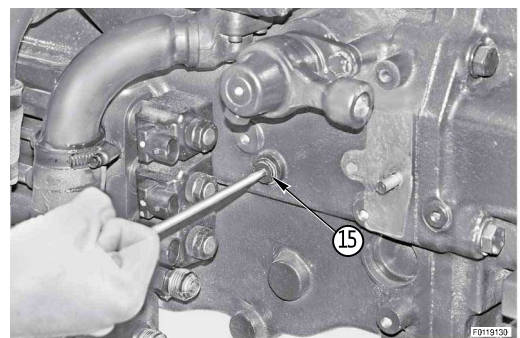

9.

Remove screw (16) and remove pipe (17).

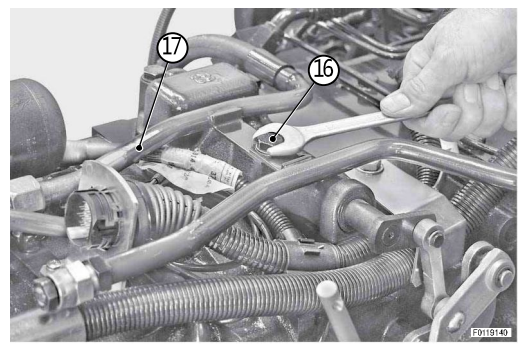

10.

Loosen union (18) and remove pipe (10).

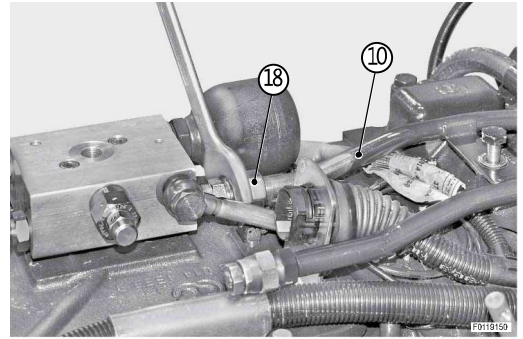

11.

Disconnect all connectors (19), remove screw (20) and redirect wiring loom (21) towards the rear of the tractor.

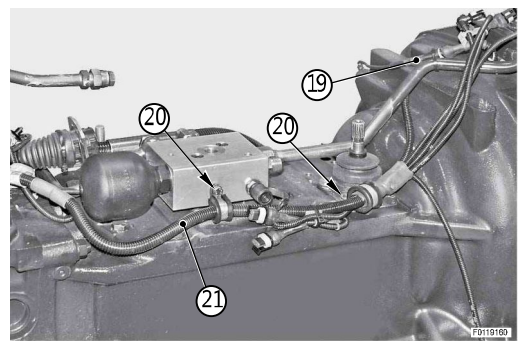

12.

Remove screws (22) and direct wiring connector (23) and wiring loom (24) towards the rear of the tractor.

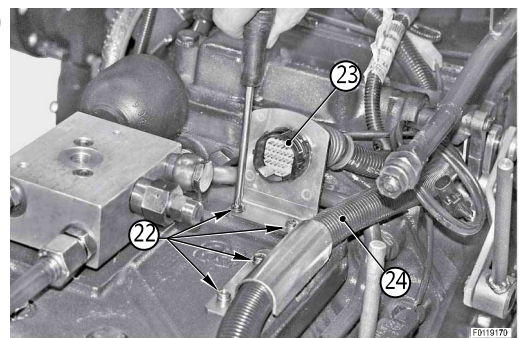

13.

Remove screws (25) and disconnect bracket (26).

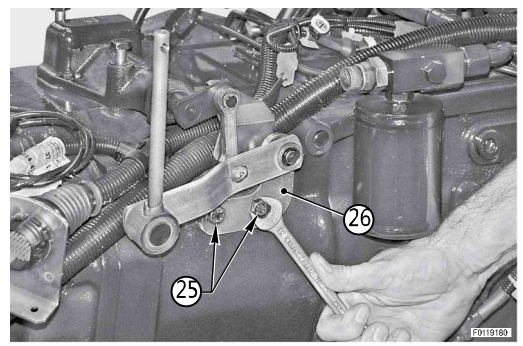

14.

Remove screws (27) and remove underdrive control (28).

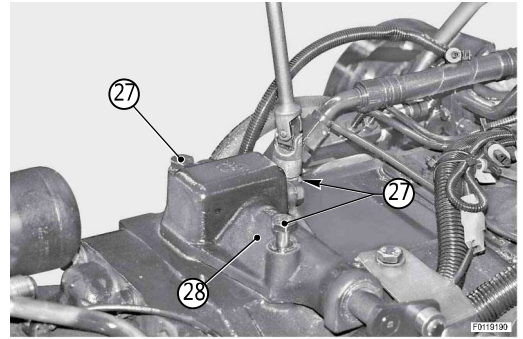

15.

Remove screws (29) and disconnect handbrake (30).

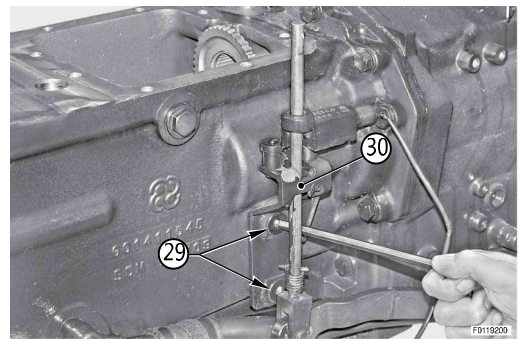

16.

Loosen clamps (31) and slide sleeve (32) onto pipe (33).

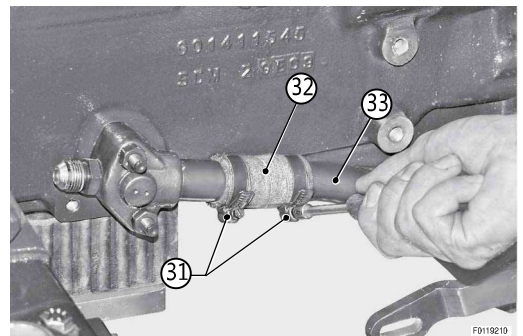

17.

For all versions

Position two stands "A" and "B" under the transmission casing.

Thank you so much for reading.
Please click the “Buy Now!”
button below to download the
complete manual.



After you pay.

You can download the most
perfect and complete manual in
the world immediately.

Our support email:

ebooklibonline@outlook.com