



## Disassembly of gearbox and shuttle assy. - complete unit - Version with HML

### Disassembly

1. Position the gearbox and shuttle assembly vertically on a flat surface.

Remove shaft assembly (13).

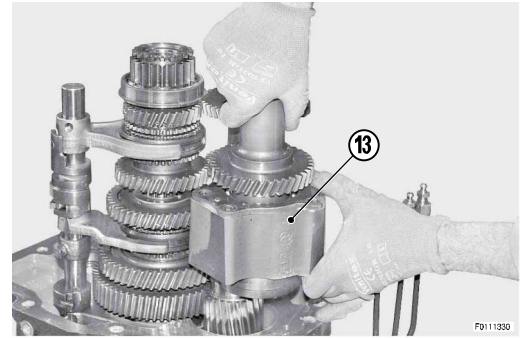

2.

Remove main shaft (15).

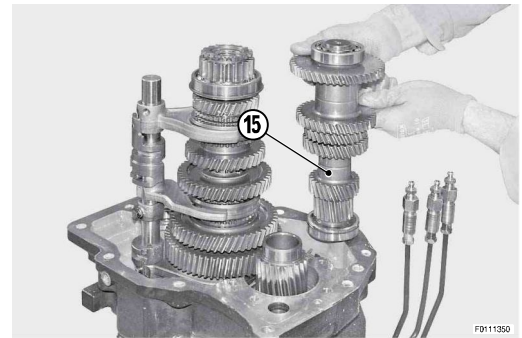

3.

Remove secondary shaft (16) and speed selector rod (17).

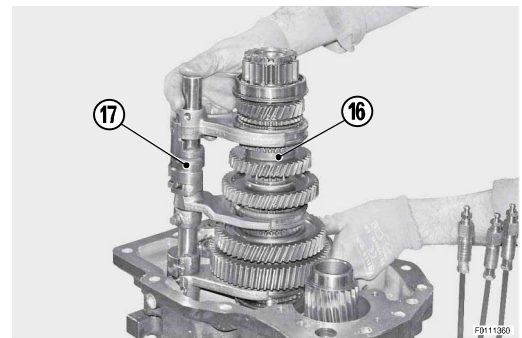

4.

Remove gear (18).

- o Take care as pulse wheel (19) will fall as soon as gear (18) is removed.

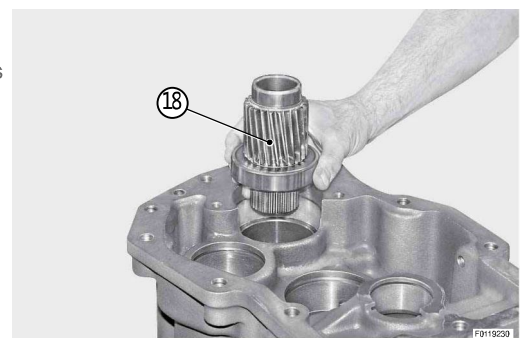

5.

## Assembly

Refitting is the reverse of removal.

T.F18.26.D0.09.00.00.01 - v1



## Gearbox and shuttle assembly - complete unit - Version without HML

### Removal



**DANGER**

1. Disconnect the lead from the battery negative terminal (-) and apply the parking brake.

Disconnect the three pipes (2) from block (1) and remove them.

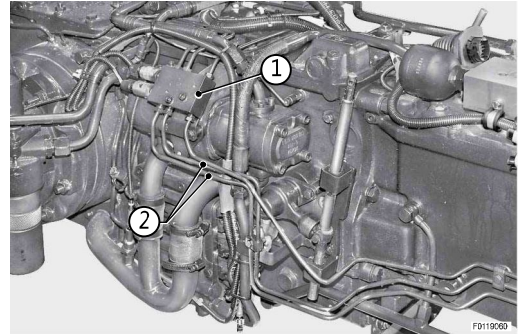

- 2.

Loosen unions (3) and (4).

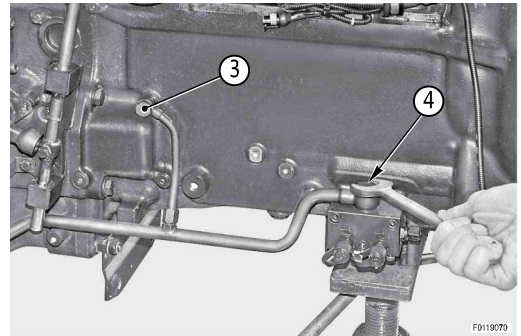

- 3.

Loosen union (5), remove screw (6).

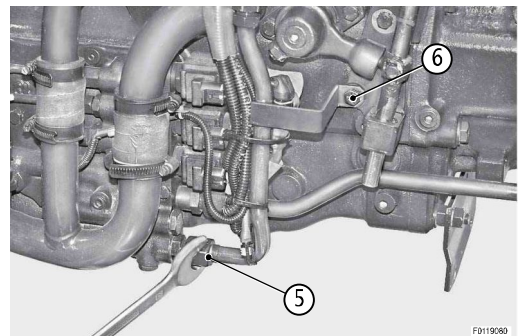

- 4.

Loosen union (7) and remove pipe (8).

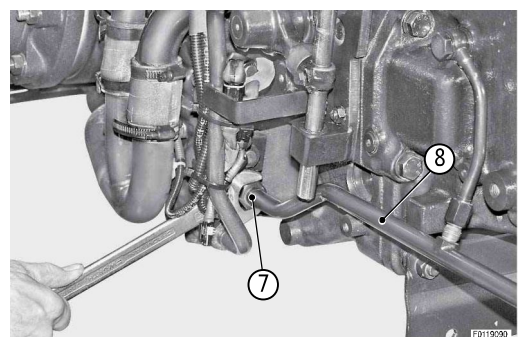

5.

Disconnect connectors (9) and move pipe (10).

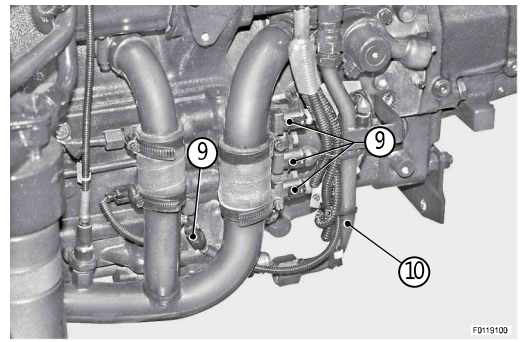

6.

Remove nuts (11) and remove lever (12).

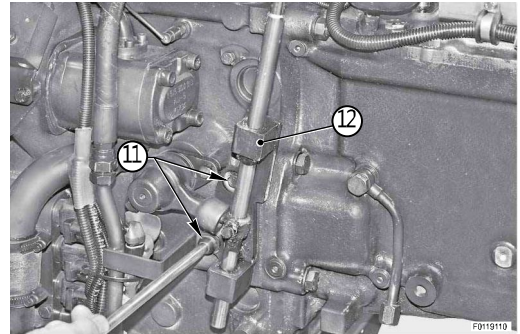

7.

Remove sensor (14) and unplug connector (13).

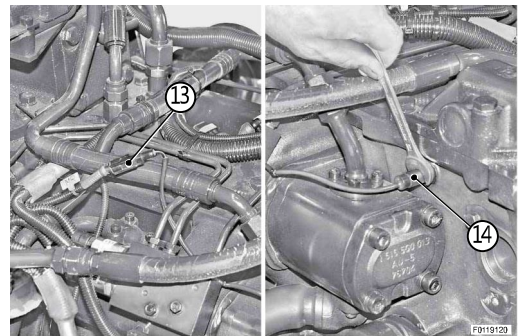

8.

Remove pin (15).

- o Renew the copper washers on reassembly.

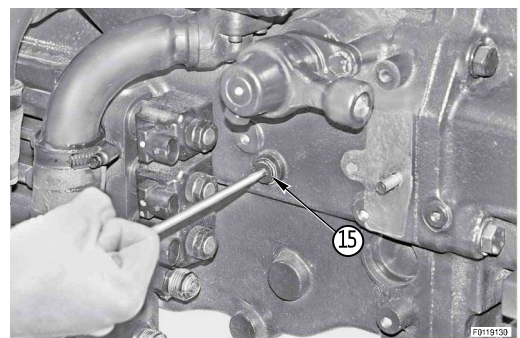

9.

Remove screw (16) and remove pipe (17).

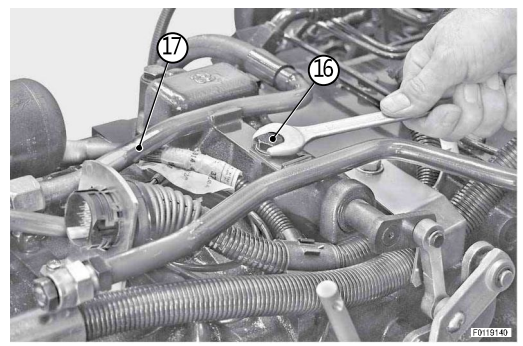

10.

Loosen union (18) and remove pipe (10).

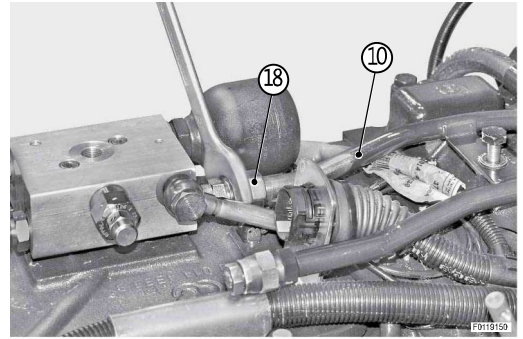

11.

Disconnect all connectors (19), remove screw (20) and redirect wiring loom (21) towards the rear of the tractor.

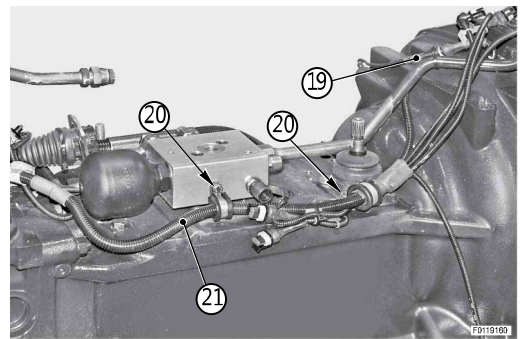

12.

Remove screws (22) and direct wiring connector (23) and wiring loom (24) towards the rear of the tractor.

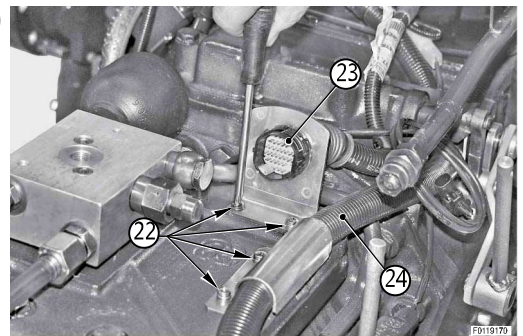

13.

Remove screws (25) and disconnect bracket (26).

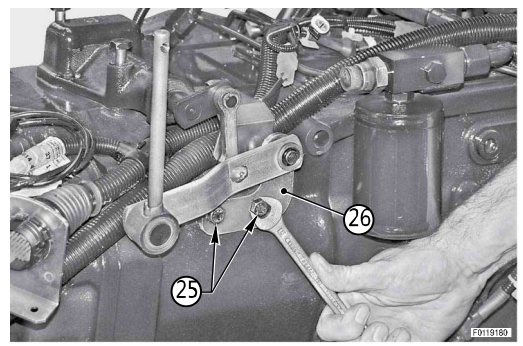

14.

Remove screws (27) and remove underdrive control (28).

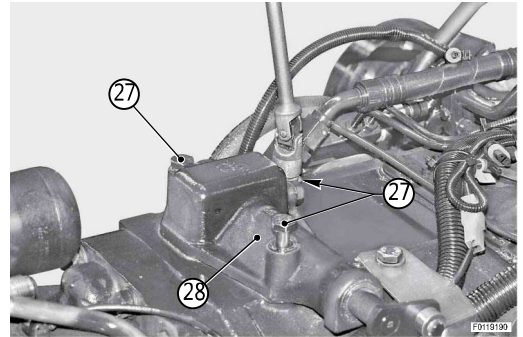

15.

Remove screws (29) and disconnect handbrake (30).

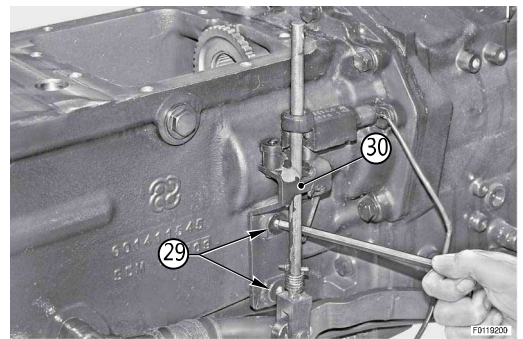

16.

Loosen clamps (31) and slide sleeve (32) onto pipe (33).

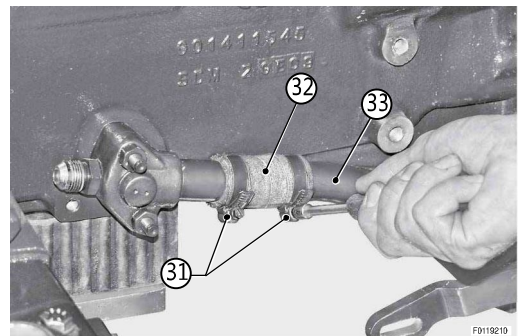

17.

**For all versions**

Position two stands "A" and "B" under the transmission casing.

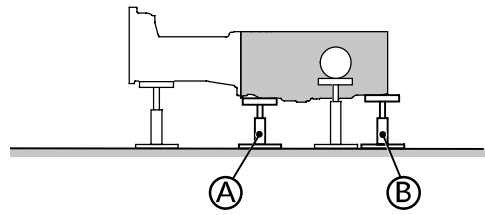

D0020790



18.

**For versions with hydraulic 4WD control only**

Remove circlip (34) from 4WD crankshaft (35) at transmission output.

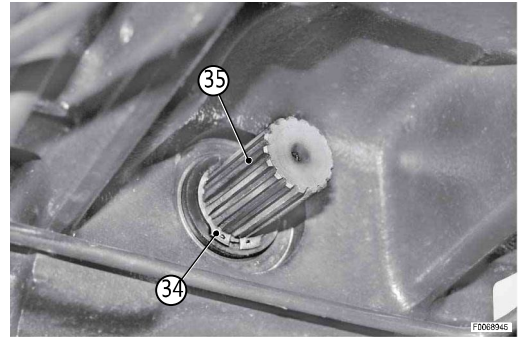

F0068945



19.

Attach clutch housing (36) to a hoist and take up the slack in the lifting sling or rope.

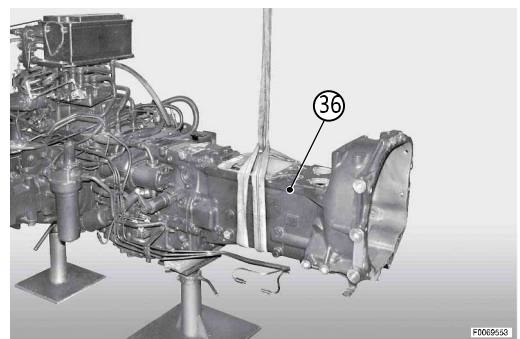

F0069553



20.

Remove the ten screws (37) and the two nuts.

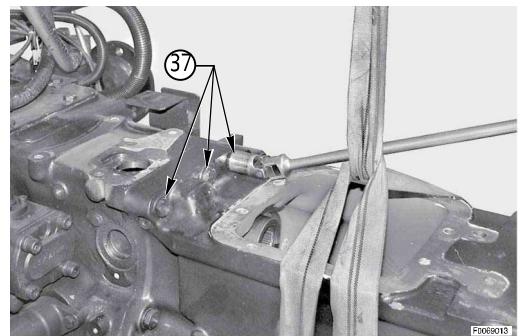

F0062013



21.

Remove clutch housing assembly (36).

- o Clutch housing: 120 kg (264 lb.)

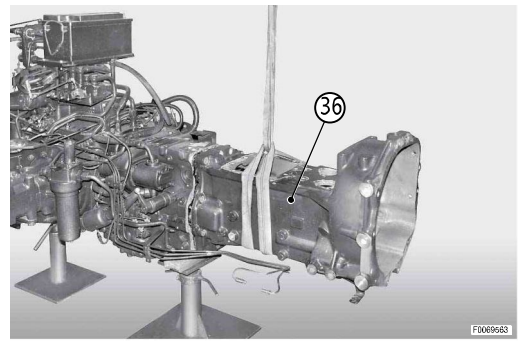

22.

## Installation

Refitting is the reverse of removal. Use caution in relation to the following procedures:

### Procedure 16

- Mating face: Loctite 510

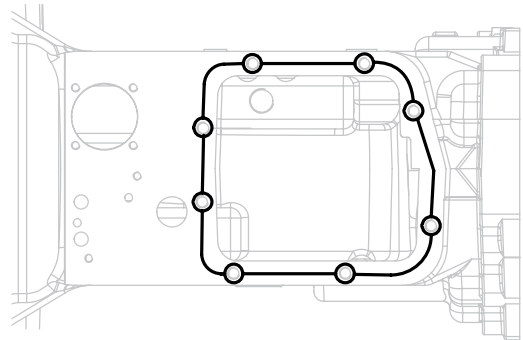

D0035650



### Procedure 22

- Screws and nuts:  $78 \pm 4$  Nm ( $57.5 \pm 3.0$  lb.ft.)  
Mating face: Loctite 510

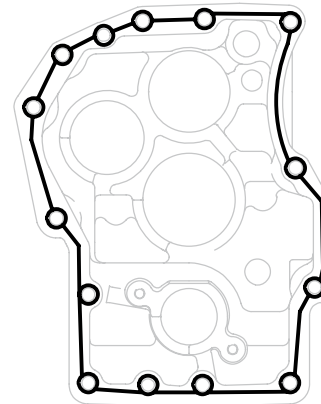

D0020230







## Disassembly of gearbox and shuttle assy. - complete unit - Version without HML

### Disassembly

1. Position the gearbox and shuttle assembly vertically on a flat surface.

Remove plug (1) and remove spring (2) and ball (3).

- o Renew the copper washers on reassembly.

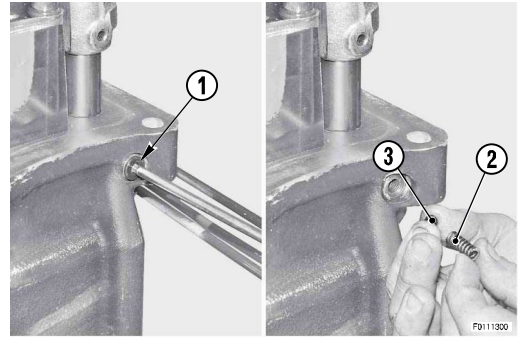

2.

Remove stop screw (4).

- o Renew the copper washers on reassembly.

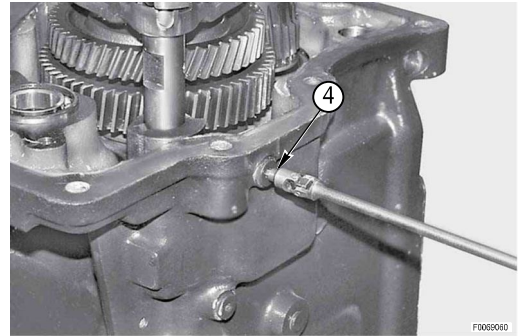

3.

Remove plug (5) and remove spring (6) and ball (7).

- o Renew the copper washers on reassembly.

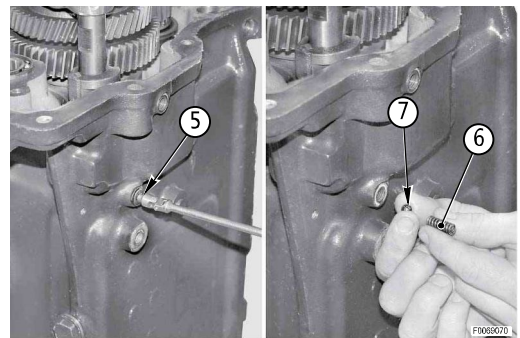

4.

Unscrew and remove screws (8).

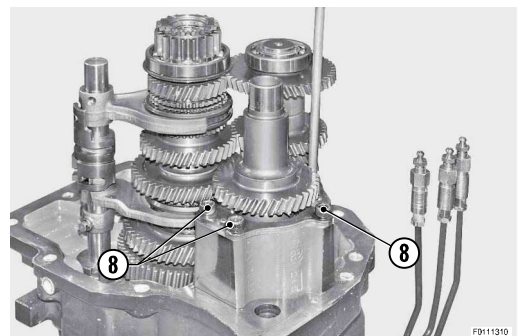

5.

Open circlips (9) securing shafts (10) and at the same time apply leverage to release bearings (11) from clutch housing (12).

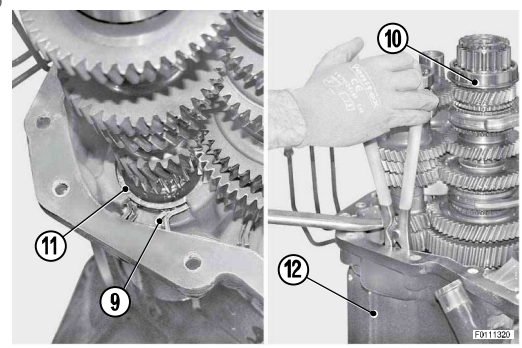

6.

Remove input shaft assembly (13) and selector rod (14).

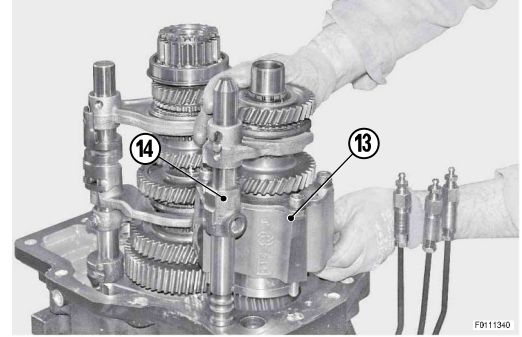

7.

Remove main shaft (15).

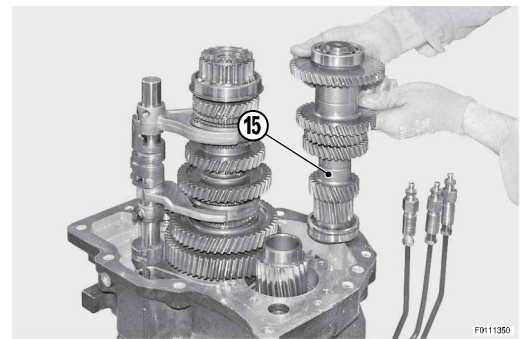

8.

Remove secondary shaft (16) and speed selector rod (17).

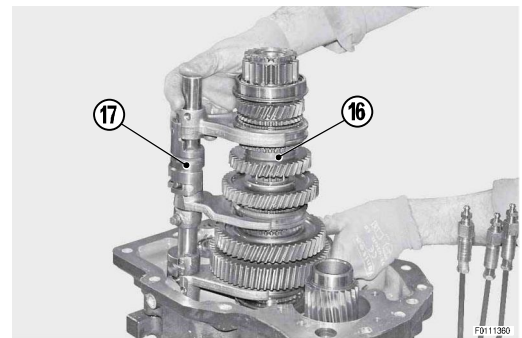

9.

Remove gear (18).

- o Take care as pulse wheel (19) will fall as soon as gear (18) is removed.

Thank you so much for reading.  
Please click the “Buy Now!”  
button below to download the  
complete manual.



After you pay.

You can download the most  
perfect and complete manual in  
the world immediately.

Our support email:

[ebooklibonline@outlook.com](mailto:ebooklibonline@outlook.com)