



Checking engine block

1. Mount main bearing caps complete with main bearing shells or main bearings on the block.



NOTE

Position the main bearing caps and main bearing shells according to the punched numbers and the marks executed on disassembly.

Fix the main bearing caps with the screws.

Screws: 92 Nm (67.8 lb.ft.)

Check the main bearings diameter and out of round with an internal dial gauge.



NOTE

Make a note of the values read for each main bearing and renew the bearing if the diameters exceed the tolerance limits specified in "TECHNICAL DATA AND DIMENSIONS".



NOTE

The main bearings must be replaced with undersize main bearings whenever the crankshaft is reground.

- 2.

Check the crankshaft main bearings diameter with an internal dial gauge.



NOTE

If the bearings exceed the permissible tolerance values specified in "TECHNICAL DATA AND DIMENSIONS" they must be replaced, and the new bearings must be bored after assembly.



NOTE

To facilitate removal of the worn main bearings and boring of the new main bearings, remove the plug on the flywheel side. When this procedure has been carried out, refit a new plug smeared with sealant.

Plug: Loctite 554

- 3.

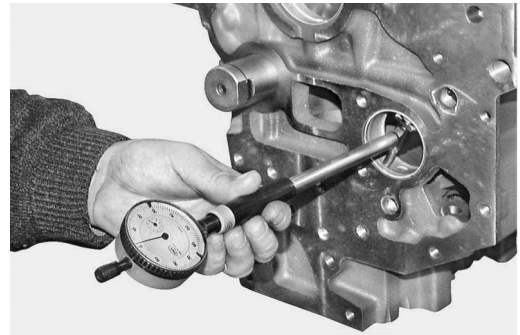
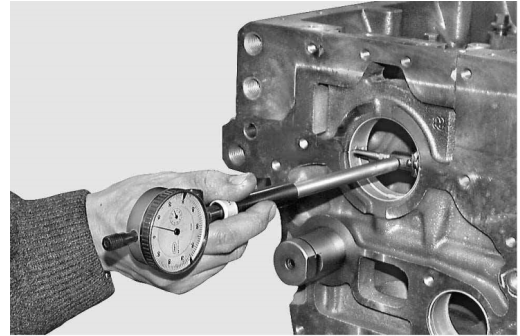



Crankshaft

Position a dial gauge on a magnetic stand "A" and preload the gauge by about 3 mm (0.118 in.) on the head of crankshaft (1). Using lever "B", pry the crankshaft axially in one of the two directions; set the dial gauge to zero and move the crankshaft in the opposite direction to check if the end float reading is within the permissible range of values. If the end float is not within the specified limits, replace the thrust washers with oversize versions (see "Technical data checks").

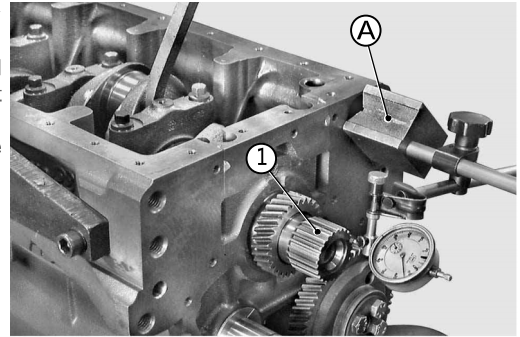

1.

Remove the screws and remove connecting rod caps (2) complete with main bearing shells (3).



NOTE

Label the main bearing shells and connecting rod for the following dimensional check.



NOTE

Note the connecting rod cap and relative connecting rod are marked with punched numbers facing the injection pumps side.



NOTE

Mark the assembly position of each connecting rod. Do not switch positions unless a general overhaul is to be carried out.

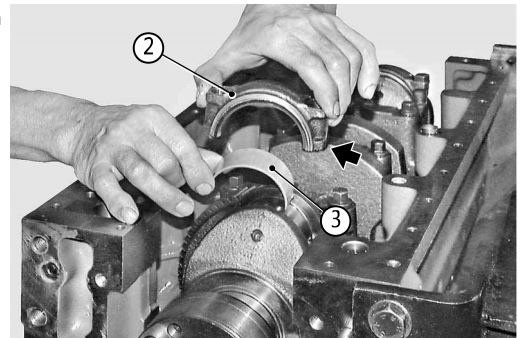

2.

Remove the screws and remove central main bearings (4) complete with the main bearing shells.



NOTE

Label the main bearing shells and main bearings for the following dimensional check.



NOTE

Note that the central main bearings have the same numerical punch marking shown on the engine block and that orientation is defined by the smaller diameter spot facings "A" facing the injection pump side.

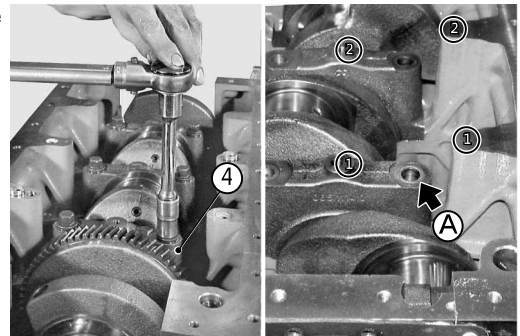

3.

Remove the screws and remove front main bearing (5) complete with main bearing shell (6).



NOTE

Label the main bearing shell and front main bearing for the following dimensional check.



NOTE

When removing the bearing remove also the triangular seals and be sure to renew them at the time of reassembly.

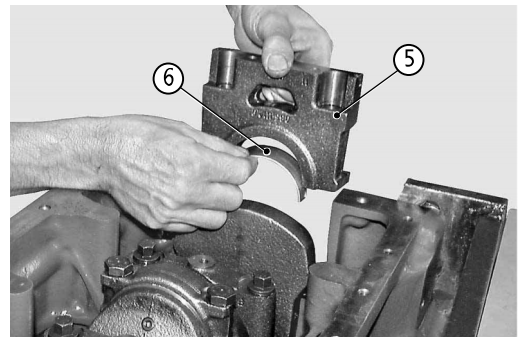

4.

Remove the screws and remove rear main bearing (7) complete with main bearing shell and crankshaft half thrust washers (8).



NOTE

Label the main bearing shell and rear main bearing for the following dimensional check.



NOTE

Note the direction of installation of the half thrust washers, the oil grooves of which must face the crankshaft are installed.



NOTE

When removing the bearing remove also the triangular seals and be sure to renew them at the time of reassembly.

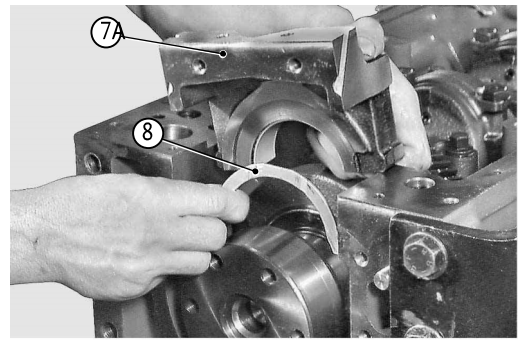

5.

Attach crankshaft (1) to a hoist with soft belt and lift it clear of the engine.

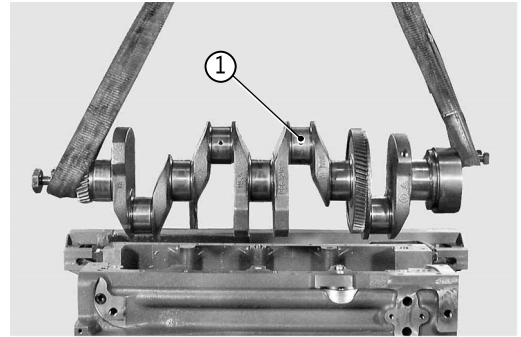

6.

Remove lower half thrust washers (9) and main bearing shells (10).



NOTE

Label the positions of the main bearing shells for the following dimensional check.

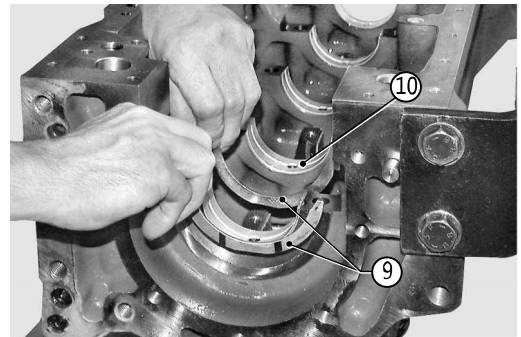

7.

Remove tappets (11) from the block.



NOTES

Carefully check that the contact surface of each tappet with the cam is perfectly smooth. Renew any tappets showing signs of a pitted or rough surface.

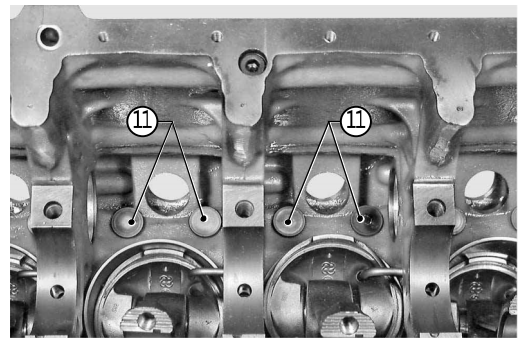

8.

Remove nut (12) and remove washer jets (13) and relative seals.

NOTE



Only if necessary: remove union (14).

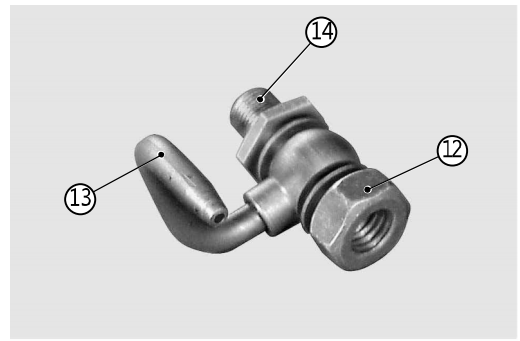

9.

Installing crankshaft

Position main bearing shells (7), with the lubrication hole, in block (6) with the lubrication hole.



NOTE

Take care to align the tabs of the shells (7) in their locations in the block (6).

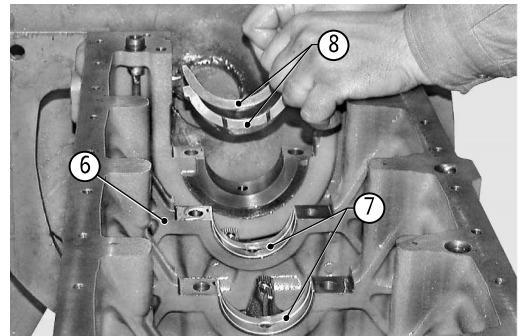

1.

2. Position the two lower half thrust washers (8).



NOTE

The oil grooves must be facing outwards.



NOTE

To hold the half thrust washers in place, smear grease on their seats.

Lubricate main bearings (7) and half thrust washers (8) liberally and fit crankshaft (9).

Main bearings and half thrust washers: Engine oil

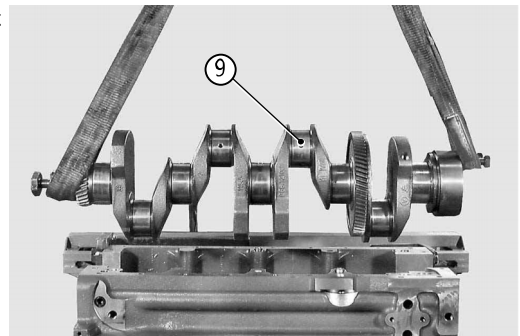

3.

Lubricate crankshaft (9) liberally and fit central main bearing shells and main bearings (10).

Crankshaft: Engine oil



NOTE

Carefully check correct orientation of main bearings (10); smaller diameter spot facing "A" must be on the injection pump side. The main bearings are numbered and must be fitted according to the punch markings on the block.

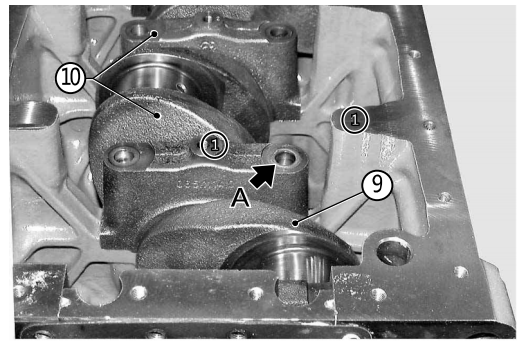

4.

Fit the upper half thrust washers (8) and triangular gaskets (12) for the lateral seals, in the rear main bearing (11).

	<p>NOTE</p> <p>Smear grease on the half thrust washers and gaskets to hold them in position; apply grease also to the exterior surface of the gaskets.</p>
---	---

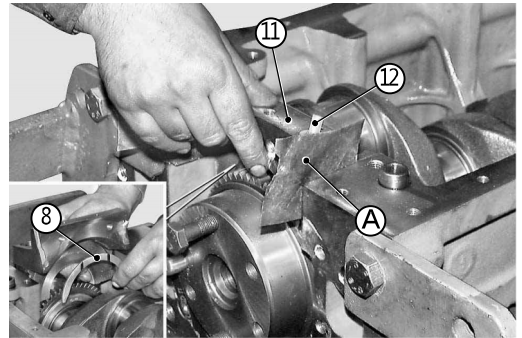

Equip the engine block with two installation guide plates "A" (thickness. 0.3 mm (0.012 in) made of soft metal, and install the rear bearing.

5.

Fix rear main bearing (11) with the screws tightened manually to hold the position; remove guide plates "A" by pulling them sideways with respect to the gasket.

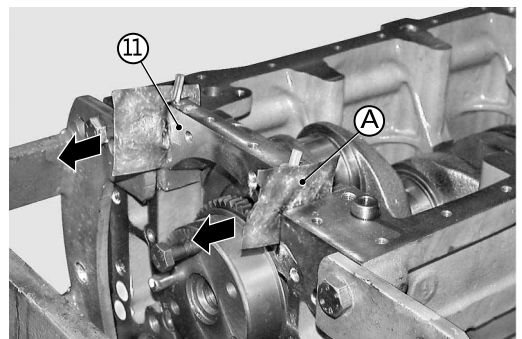

6.

Install the front main bearing (13) by means of the same procedure utilised for the rear main bearing.

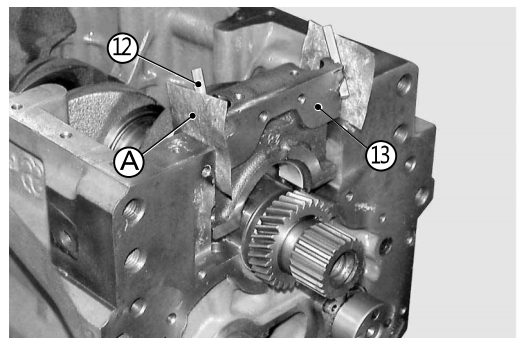

7.

Tighten the 5 screws (14) of main bearings (15) to the 1st torque stage with a torque wrench.

Screws: 1st stage = 10 Nm (7.4 lb.ft.)

Using a torque wrench, tighten the main bearing screws to the specified pre-torque value.

Screws pre-torque: 40 Nm (29,5 lb.ft.)





DANGER

Before proceeding, check that end float is within tolerance limits given in "Technical data and dimensions (For the procedures, see "Removing the crankshaft").

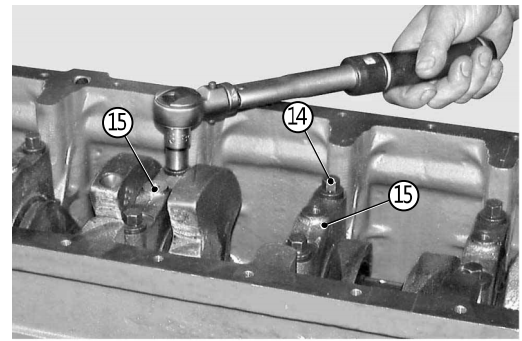

8.

Using the same torque wrench and angular tightening protractor T17 (code 5.9030.640.0), tighten main bearing screws (11) and (13).

Screws: Angle-tighten through $55^{\circ} \pm 1^{\circ}$

Check that the crankshaft rotates freely with no points of stiffness.

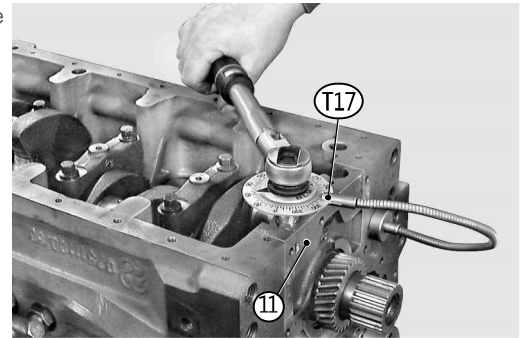

9.

Trim off the protruding part of the triangular gaskets (12) for lateral sealing of the front and rear main bearings. Ensure that the gasket protrusion is no more than 0.2 mm (0.008 in.).

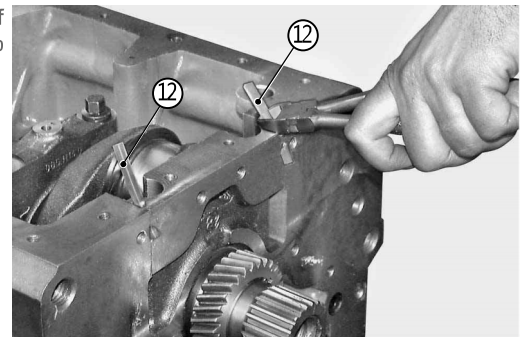

10.

Fit bearing half-shells (19) in connecting rods (18).

NOTE



Take care to align the tabs of bearing half-shells (19) in their locations in connecting rod (18).

Lubricate the bearing half-shells and engage the connecting rods on the crankshaft.

- o Bearing half-shells: Engine oil.

NOTE



Take care to install the connecting rods the right way round; the side marked with the punched number must face the injection pump side.

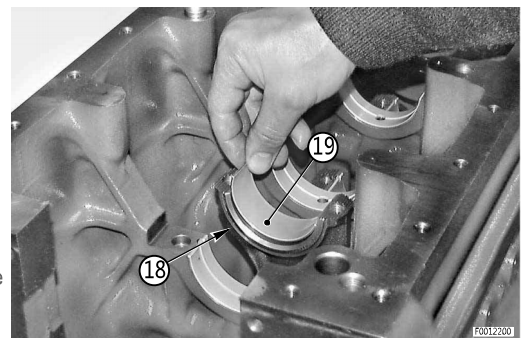

11.

Lubricate the crankshaft and fit the big-end bearing caps (20) complete with half shells.

Hand tighten the screws of the big-end bearing caps (20).

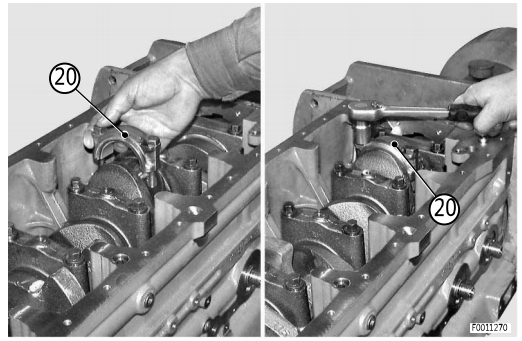

12.

Using a torque wrench, tighten screws (21) of the big-end bearing caps (20) to Stage 1 torque.

- o Screws: 10 Nm (7.4 lb.ft.)

Still with a torque wrench, tighten screws (21) to Stage 2 torque.

- o Screws pre-torque: 30 Nm (22.1 lb.ft.)

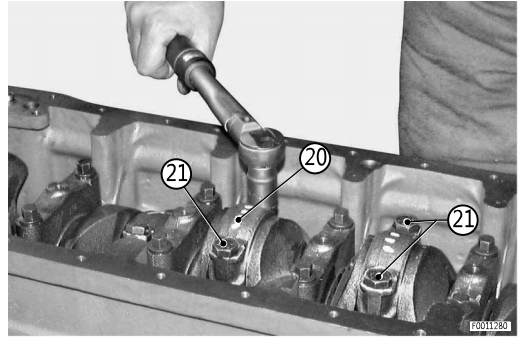

13.

Using the same torque wrench and angular tightening protractor T17 (code 5.9030.640.0), fully tighten connecting rod screws (21).

- o Screws: Angle-tighten through $90 \pm 1^\circ$

Check that the crankshaft rotates freely with no points of stiffness.



NOTE

Check during crankshaft rotation that the cooling oil spray is perfectly aligned with the hole of the piston chamber.

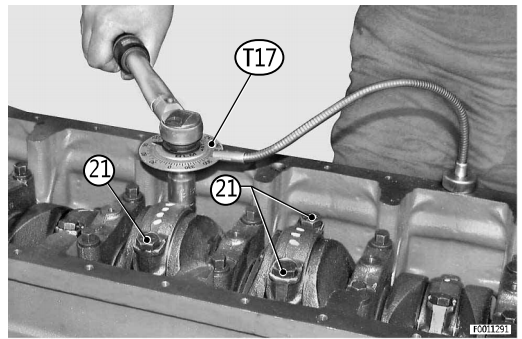

14.



Crankshaft checks

Check the diameter of the main bearing journals and crankpins with the micrometer gauge.



NOTE

Check at various points and **all** around the circumference to detect also taper and out of round.

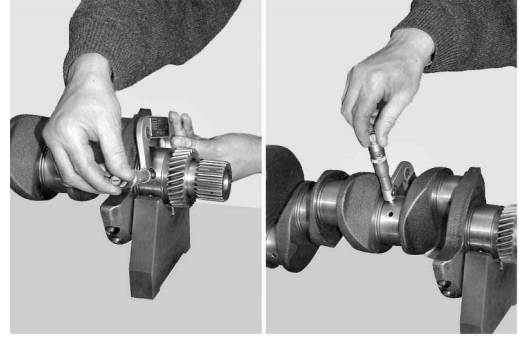

1.

If dimensional and geometrical errors exceed the tolerances specified in "TECHNICAL DATA AND DIMENSIONS" (even on a single crankpin or main journal), grind the entire crankshaft, reducing the diameters of the main journals and crankpins to one of the possible undersize diameters indicated.



NOTE

If the crankshaft is reground, the main bearings and crank bushes must be replaced.

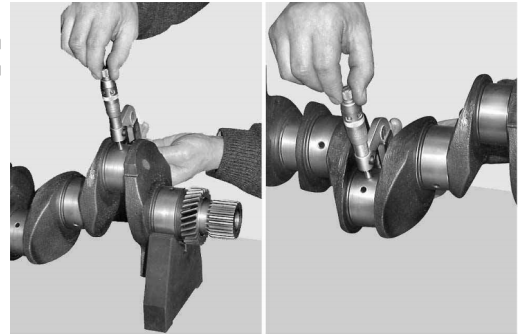

2.

Only if necessary

Using puller T12 (P/N 5.9030.008.4/10) to remove timing gear (1) from the crankshaft.

Heat the new gear on a thermostatic hotplate to approx. 100°C and fit it to the crankshaft, making sure that it is located fully home against the thrust washer.



NOTE

Check the condition of the key.

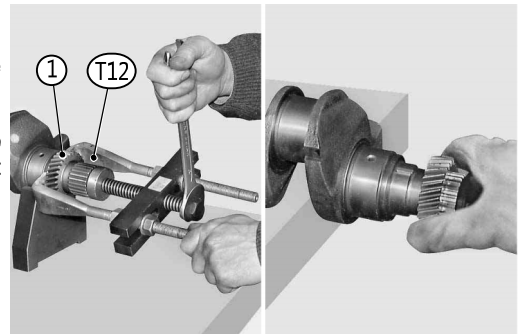

3.

6-cylinder version

If necessary, renew the lubrication oil pump drive gear.

Using puller T12 (P/N 5.9030.008.4/10), remove oil pump drive gear (2).



NOTE

Remove sealant residues from the crankshaft.

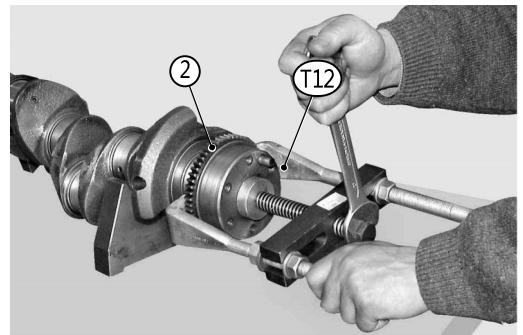

4.

Heat the new gear on a thermostatic hotplate to a temperature approx. 100°C above the crankshaft temperature.

Apply sealant to the area of the crankshaft that will receive the gear.

Crankshaft: Loctite 648

Fit gear (2) on crankshaft (3) at distance "A" from crankshaft thrust surface (3).



NOTE

A = 0.2...0.5 mm (0.079...0.197 in.).

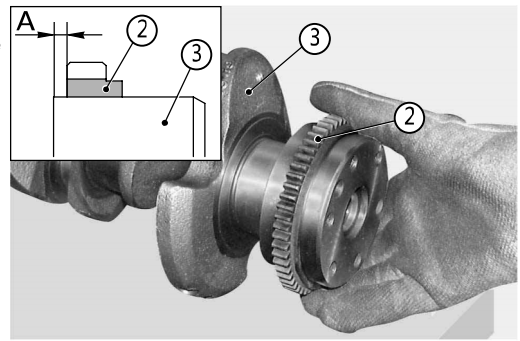

5.

After cooling the gear, remove excess sealant and check that lateral oscillation of the gear does not exceed 0.1 mm (0.004 in.) at a the height of the 116 mm diameter (4.56 in.).



NOTE

If lateral oscillation exceeds 0.1 mm (0.004 in.), use a punch made of soft metal (copper, aluminium, brass) to return the gear to within tolerance.

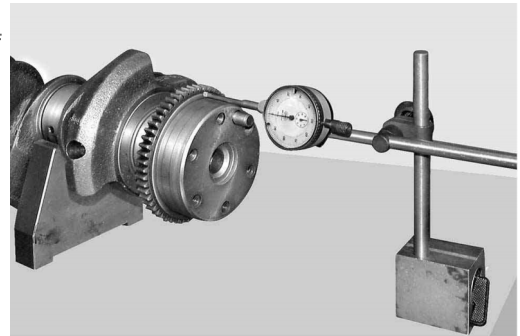

6.



Flywheel checks

1. The checks relative to the flywheel are as follows:

- o Visual inspection of ring gear conditions.
- o Check radial runout (post-assembly check).
- o Check face runout (post-assembly check).

If the ring gear is damaged, remove it using a puller.



NOTE

Tap the ring gear all the way around until removing it.



NOTE

Note the direction of assembly of the ring gear; The bevelled side of the teeth must face outwards.

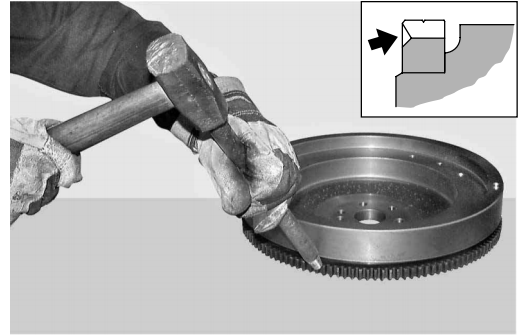

2.

Clean the seat with care, heat the new ring gear on a thermostatic hotplate to approx. 100°C and then fit it to the flywheel, making sure that it is fully seated.



3.

After having fitted the flywheel to the crankshaft and tightened down the retaining bolts, use a dial gauge with magnetic stand to check the radial and face runout.



NOTE

The max. permissible error is 0.10 mm (0.004 in.).



NOTE

For the tightening torque, see "ENGINE ASSEMBLY".

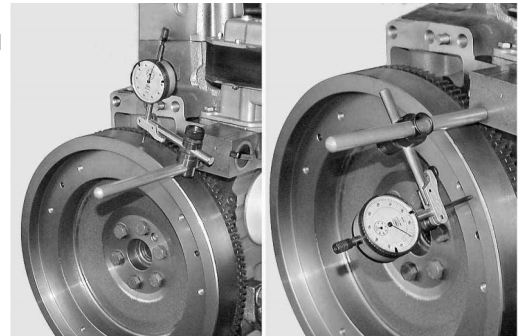

4.

Thank you so much for reading.
Please click the “Buy Now!”
button below to download the
complete manual.



After you pay.

You can download the most
perfect and complete manual in
the world immediately.

Our support email:

ebooklibonline@outlook.com