

Page Title	Page Number
100 - TOLL'S BOX	101-01-108
100 - ADHESIVES (SPANISH)	101-02E-112
100 - ADHESIVES (ENGLISH)	101-02I-115
100 - ADHESIVES (PORTUGUESE)	101-02P-109
100 - ADHESIVES (SPANISH)	101-03E-113
100 - ADHESIVES (ENGLISH)	101-03I-116
100 - ADHESIVES (PORTUGUESE)	101-03P-110
100 - ADHESIVES (SPANISH)	101-04E-114
100 - ADHESIVES (ENGLISH)	101-04I-117
100 - ADHESIVES (PORTUGUESE)	101-04P-111
20 - CYLINDER BLOCK	21-01-119
20 - FLYWHEEL AND GEAR RIM	21-04-262
20 - CYLINDER HEAD	21-05-121
20 - VALVE MECHANISM	21-07-123
20 - CRANKSHAFT MECHANISM	21-09-853
20 - GEAR HOUSING	21-11-125
20 - ENGINE OIL COOLER	21-12-126
20 - SUMP	21-14-790
20 - AIR FILTER	21-16-128
20 - INLET AND EXHAUST MANIFOLD	21-17-129
20 - MUFFLER	21-18-130
20 - TURBOCHARGER	21-19-131
20 - INSTALATION AIR FILTER	21-20-148
20 - SEDIMENTATION FILTER	22-01-132
20 - FEED PUMP AND FUEL FILTER	22-02-133
20 - INJECTION PUMP	22-03-135
20 - THROTTLE SYSTEM	22-05-137
20 - RADIATOR	23-01-138
20 - WATER PUMP AND FAN	23-02-139
20 - GASKET SET S1	28-01-1003
20 - GASKET KIT S1 + S2	28-02-1004
20 - REPAIR KIT	28-05-146
30 - STARTER MOTOR - BOSCH	31-01-29
30 - STARTER MOTOR - ISKRA	31-02-531
30 - ALTERNATOR - 55A	31-03-150
30 - ALTERNATOR BOSCH - 90A	31-04-1283
30 - REAR ELETRICAL SYSTEM FOR CAB	32-01-157
30 - REAR ELETRICAL SYSTEM FOR CAB	32-03-155
30 - INSTRUMENTS	32-04-151
30 - LIGHTS	32-05-152
30 - PANEL ELETRIC SYSTEM	32-06-153
30 - FRONT ELETRIC SYSTEM	32-07-154
30 - ROTATING LIGHT (OPTIONAL EQUIPMENT)	39-01-162
30 - RADIO (OPTIONAL)	39-02-1350
30 - FRONT WINDOW WIPER AND WASHER (OPTIONAL)	39-03-302
30 - REAR WINDOW WIPER AND WASHER	39-04-38
30 - REAR FOG LIGHT (OPTIONAL)	39-05-159
30 - LIGHT NUMBER PLATE	39-07-160
40 - CLUTCH	41-02-164
40 - HOUSING GEAR BOX AND DRIVE SYSTEM	42-01-165

TABLE OF CONTENT

40 - GEAR SHIFT LEVERS	42-02-166
40 - COUNTERSHAFT	42-03-169
40 - MAINSHAFT	42-04-168
40 - BEVEL CONICAL PINION SHAFT	42-05-170
40 - BEVEL CONICAL PINION SHAFT (TAB)	42-06-301
40 - TRANSMISSION DIFFERENTIAL	42-07-167
40 - VALVE PLATE	42-08-171
40 - TRANSMISSION COOLING	42-10-173
40 - MULTITORQUE CONTROL	44-01-174
40 - SHIFT ON THE GO UNDER DRIVE	44-02-175
40 - SHIFT ON THE GO UNDER DRIVE	44-03-176
40 - POWER TAKE OFF 540 RPM	46-01-177
40 - POWER TAKE OFF 540 - 1000 RPM	46-02-178
40 - POWER TAKE OFF 540 RPM PROPORCIONAL	46-03-179
40 - REAR HOUSING AND PTO LEVER	46-04-180
40 - REAR COVER	46-05-181
50 - FINAL DRIVE	51-01-182
50 - DIFFERENTIAL LOCK DRIVE	51-02-183
50 - BRAKE CONTROL DRIVE	51-03-184
60 - STEERING WHEEL COLUMN	61-01-185
60 - HYDRAULIC STEERING (4x4)	61-04-775
60 - HYDROSTATIC STEERING UNIT DANFOSS	61-07-189
60 - FRONT DRIVE SELECTING LEVER	63-01-192
60 - FRONT AXLE DANA (4x4)	64-02-194
60 - BEVEL GEAR, PINION AND DOUBLE JOINT - DANA	64-03-195
60 - DIFFERENTIAL DANA	64-04-196
60 - PLANETARY GEAR HOUSING AND WHEEL HUB - DANA	64-05-197
60 - STEERING CYLINDER AND ARM - DANA	64-06-198
60 - FRONT AND REAR BEARINGS, ZF AXLE - APL 350	65-02-469
60 - FRONT DRIVE AXLE ZF APL350	65-03-922
60 - DOUBLE JOINT - AXLE ZF APL350	65-04-492
60 - FRONT AXLE CASING ZF AS3050	65-05-1527
60 - CROWN GEAR/BEVEL PINION SHAFT AND REAR SUPPORT - ZF AS3050	65-06-1528
60 - DIFFERENTIAL - ZF AS3050	65-07-1529
60 - JOINT HOUSING - ZF AS3050	65-08-1530
60 - PLANETARY GEAR - ZF AS3050	65-09-1531
60 - STEERING CYLINDER - ZF AS3050	65-10-1532
60 - MULTITORQUE	65-11-1904
70 - FUEL TANK	71-02-214
70 - FRONT WHEEL (4x4)	72-02-210
70 - REAR WHEEL	72-04-862
70 - REAR WHEEL (OPTIONAL)	72-05-212
70 - DOUBLE REAR WHEEL 13.6 X 38, 14.9 X 28	72-06-1545
70 - BUFFER AND FRONT COUNTERWEIGHT	79-01-205
70 - REAR WHEEL COUNTERWEIGHTS (TYRE 18.4 x 34,18.4 x 30 and 13.6 x 38))	79-03-208
70 - REAR WHEEL COUNTERWEIGHTS (TYRE 23.1 x 26 e 23.1 x 30))	79-04-1364
70 - REAR WHEEL COUNTERWEIGHT - ACCESSORY	79-05-1367
80 - ROOF	81-01-226
80 - CAB FRAME	81-02-222
80 - DOOR AND GLASS OF THE CAB	81-03-224
80 - WINDSCREEN	81-04-223
80 - REAR WINDOW AND GLASS OF THE CAB	81-05-225

TABLE OF CONTENT

80 - CAB INSULATOR	81-06-220
80 - INSULATING AND COATING FOR CAB	81-07-221
80 - OLD SEAT MODEL	81-08-230
80 - SEAT (PART 1)	81-09-1287
80 - SEAT (PART 2)	81-10-1286
80 - SEAT (PART 3)	81-11-1285
80 - FRONT AND REAR MUDGUARDS	81-13-1533
80 - INSTRUMENTS PANEL	82-01-215
80 - OPEN CAB	83-01-218
80 - FRONT SHIELDS	83-03-217
80 - SAFETY FRAME AND ROOF (OPTIONAL)	89-01-219
80 - AIR CONDITIONING (OPTIONAL)	89-02-1836
80 - HEATING UNIT	89-04-227
90 - HYDRAULIC PUMP	91-01-240
90 - HYDRAULIC PUMP AND PIPE SYSTEM	91-04A-1550
90 - HYDRAULIC PUMP AND PIPE SYSTEM	91-04-1536
90 - LIFT ARM	91-07-233
90 - BY-PASS AND PRESSURE RELIEF VALVE	91-08-232
90 - HYDRAULIC CONTROL LEVERS AND CONTROL	91-09-231
90 - UPPER LINK ROD AND SENSITIVITY SYSTEM	91-10-234
90 - LIFT CONNECTION AND STABILIZER	91-11-235
90 - LIFT CYLINDER	99-01-241
90 - DIRECTIONAL CONTROL VALVE - NEW	99-02A-1538
90 - DIRECTIONAL CONTROL VALVE - ANTIQUE	99-02-243
90 - TRAILER HITCH	99-03-242

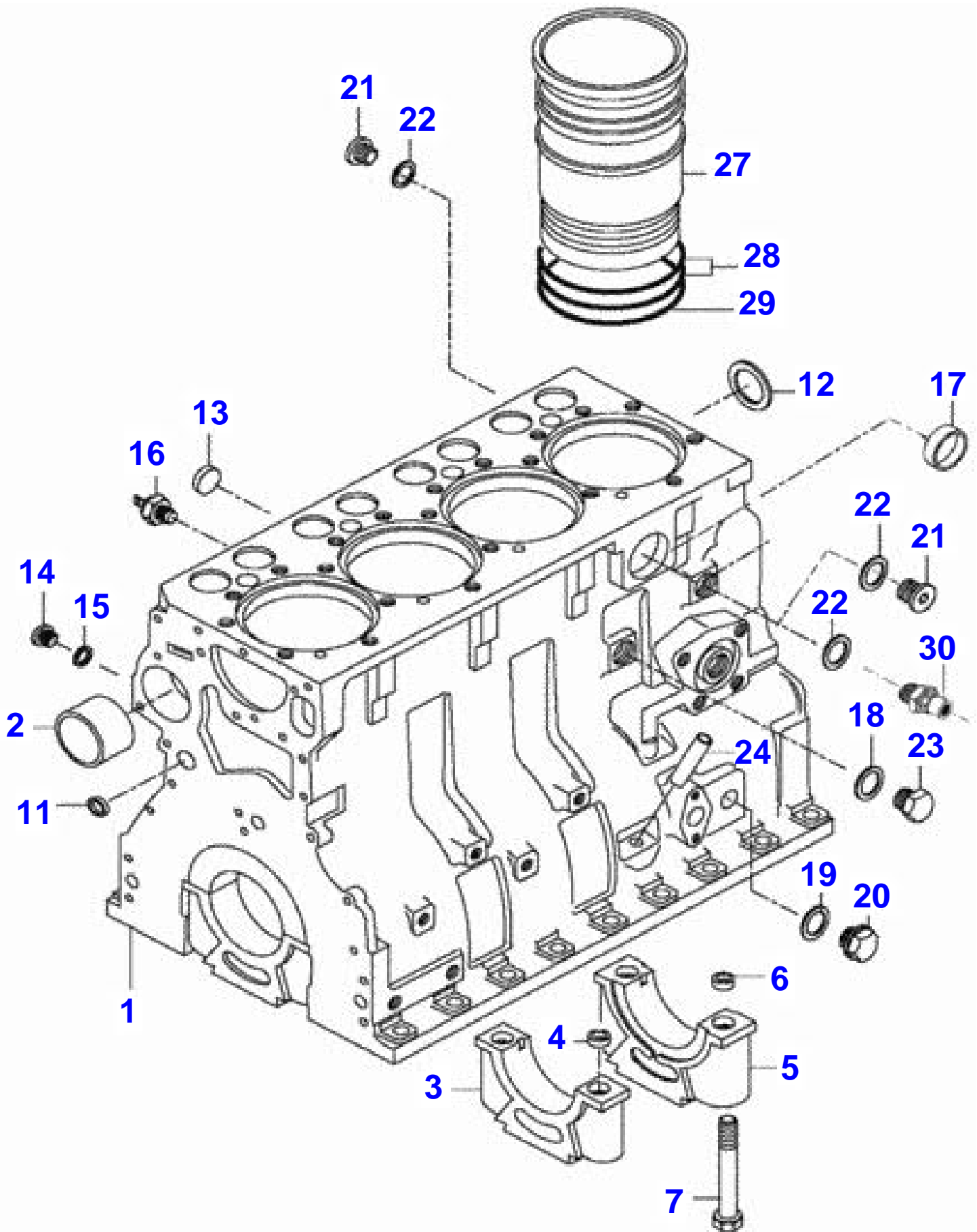

20 - CYLINDER BLOCK

Item	Part Number	Qty	Description
1	V836766377	1	Assy cylinder block
2	V836866069	1	Bushing
3		4	Bearing cover *
4	V836214478	8	Guide bushing
5		1	Bearing cover *
6	V836214478	2	Guide bushing
7	V529903180	10	Screw
11	V640016016	4	Plug ring cylinder block
12	V836529872	1	Plug
13	V640016018	1	Plug
14	VGR0261	1	Plug
15	V615571014	1	Seal ring
16	V887283760	1	Pressure switch
17	V640016040	1	Plug
18	VKH3617	1	Seal ring
20	V640305012	1	Plug
21	V640325018	1	Plug
22	VKH4946	2	O-ring
23	V836019756	1	Plug
24	V836014334	1	Pipe
27	V836647420	4	Cylinder liner Std - flange 9,03 mm
	V836647933	4	Cylinder liner flange 9,08 mm
	V836647934	4	Cylinder liner flange 9,13mm
	V836647935	4	Cylinder liner flange 9,23 mm
28	V836647502	8	O-ring, cylinder liner
29	V836647503	4	O-ring, cylinder liner
30	V836119837	1	Connection

* Delivered only complete with block

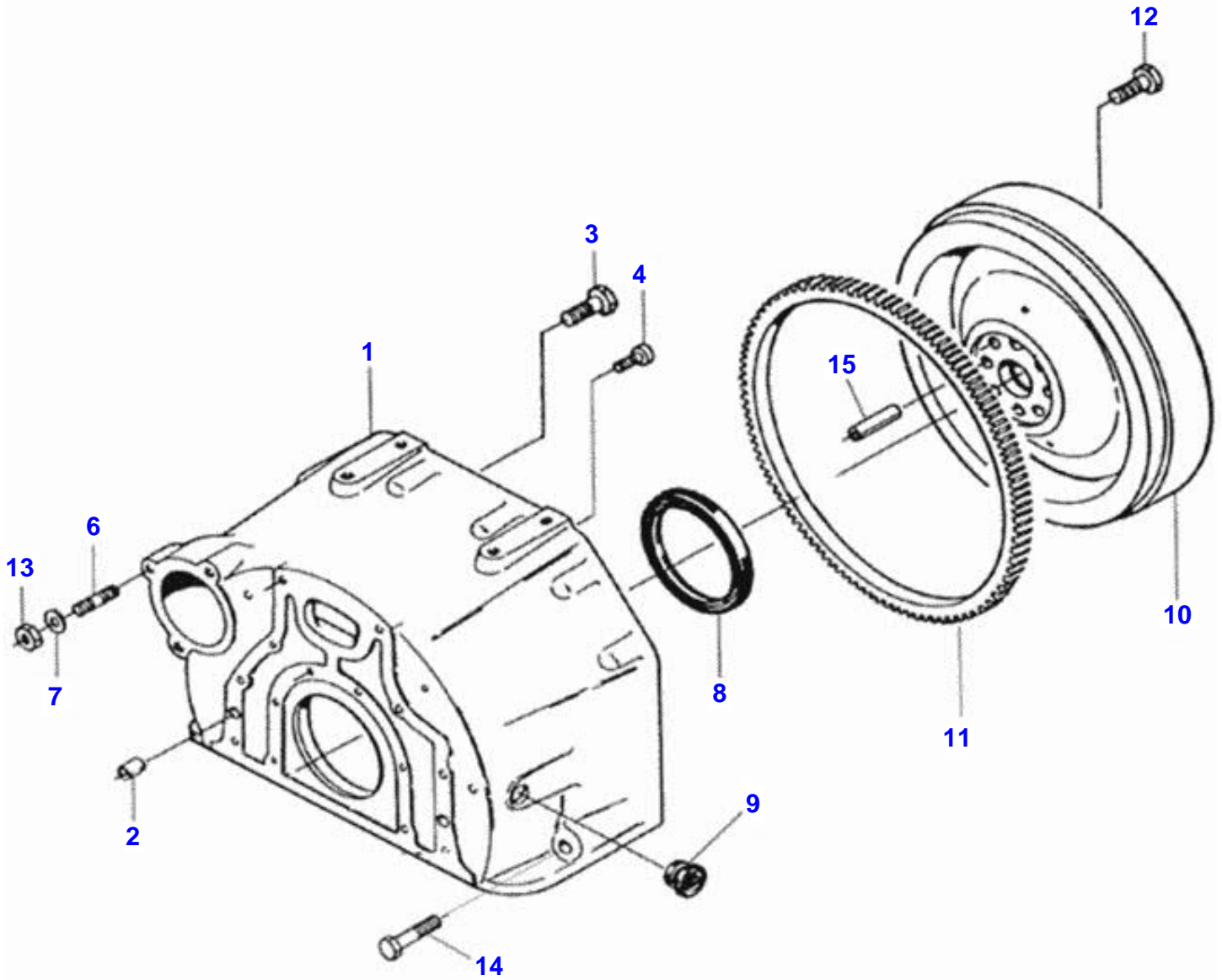

Item	Part Number	Qty	Description
1	V836647439	1	Flywheel housing
2	V598359850	2	Pin
3	V52890220	15	Screw
4	V581705030	6	Screw
6	V546801800	1	Stud bolt
7	V500951000	3	Washer
8	V614500002	1	Oil seal, crankshaft
9	V836007572	1	Plug
10	V82609500	1	Flywheel and housing
11	V835328783	1	Gear rim
12	V528902230	8	Screw
13	V504601000	3	Nut
14	VHC8519	2	Screw
15	V595955060	1	Pin

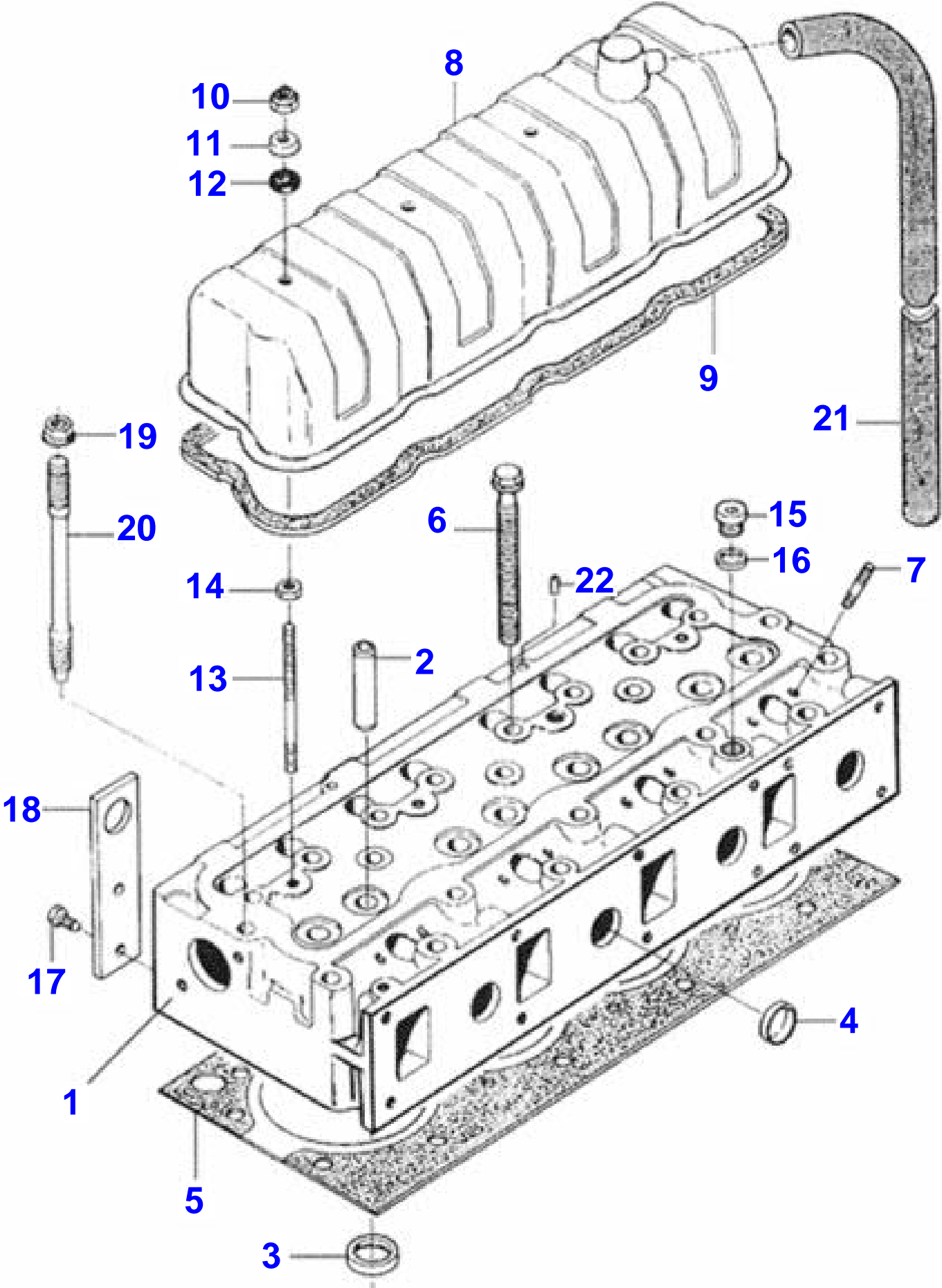

20 - CYLINDER HEAD

Item	Part Number	Qty	Description
1	V836755385	1	Cylinder head
2	V836673175	8	Valve guide
3	V836647600	4	Valve seat
	V836647936	4	Intake valve
4	V836647942	7	Cover
5	V836766301	1	Cylinder head gasket
6	V836646383	20	Screw
7	V546901435	8	Stud bolt
8	V836746361	1	Cover
9	V836746362	1	Gasket
10	VJB8905	4	Nut
11	V836119855	4	Washer
12	V836012841	4	Rubber washer
13	V546801900	4	Stud bolt
14	VJB1110	4	Nut
15	V640325018	1	Plug
16	V615881822	1	Support of the seal
17	V528801380	4	Screw
18	V836855349	2	Suspension lifteye
19	V836859110	2	Nut
20	V836859109	2	Stud bolt
21	V836755007	1	Hose
22	V595953360	2	Pin

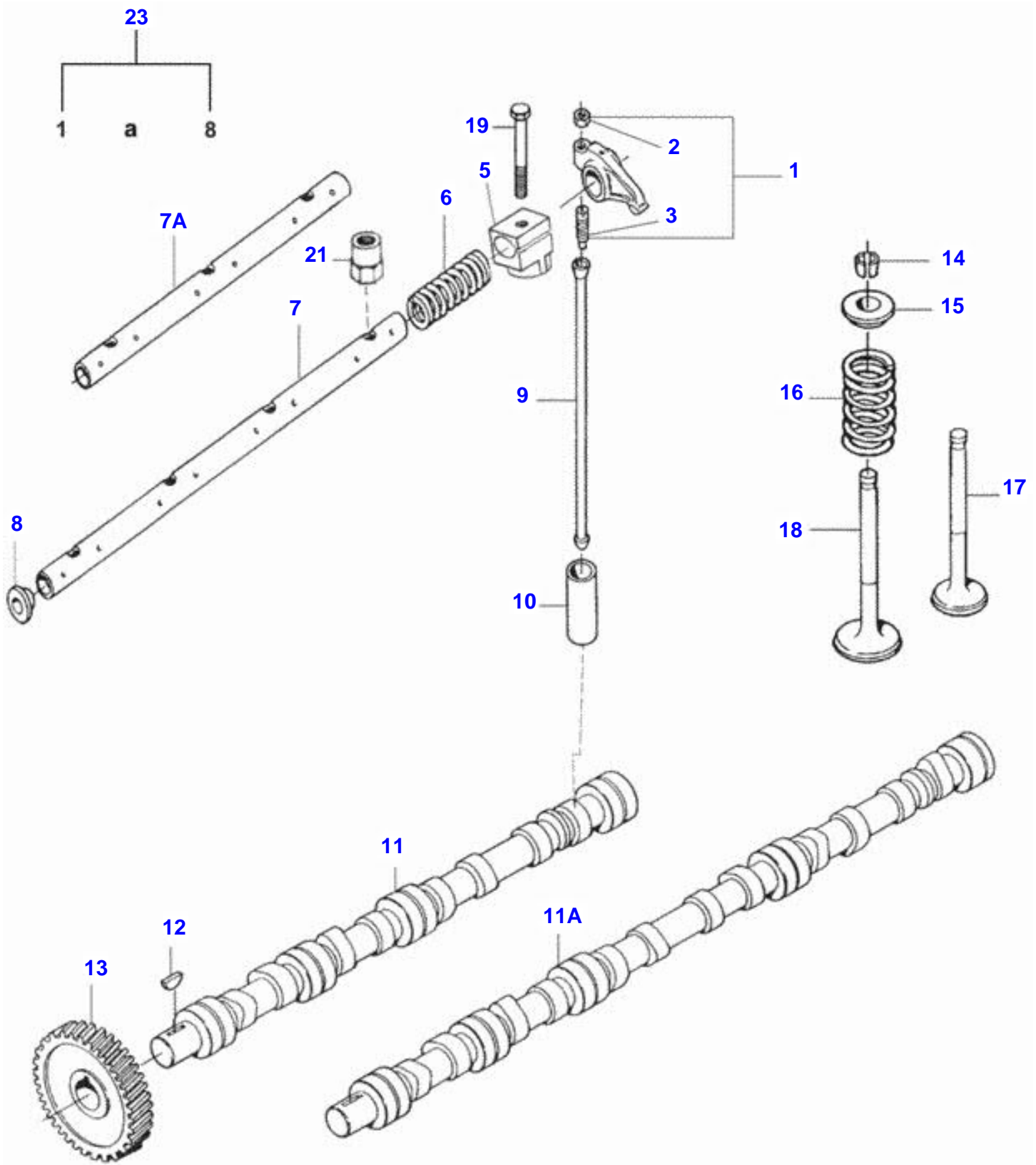

20 - VALVE MECHANISM

Item	Part Number	Qty	Description
1	V836666608	8	Assy rocker arm Ref. 2 e 3
2	V512861000	8	Nut
3	V836655866	8	Screw
5	V836666609	4	Bracket
6	V836655884	3	Spring
7	V836755871	1	Shaft
8	V836655899	2	Plug
9	V836655867	8	Push rod
10	V836014264	8	Valve tappet
11	V836746375	1	Valve control axle
12	V603305760	1	Shifting
13	V836647381	1	Gear
14	V836646382	16	Valve cotter
15	V836646381	8	Spring plate
16	V836646380	8	Spring
17	V836646357	4	Exhaust vale
18	V836646356	4	Intake valve
21	V836655406	4	Nut
23	V836766611	1	Valve mechanism - assembly Ref. 1,2,3,5,6,7,8

BM110 TRACTOR (BRAZIL)

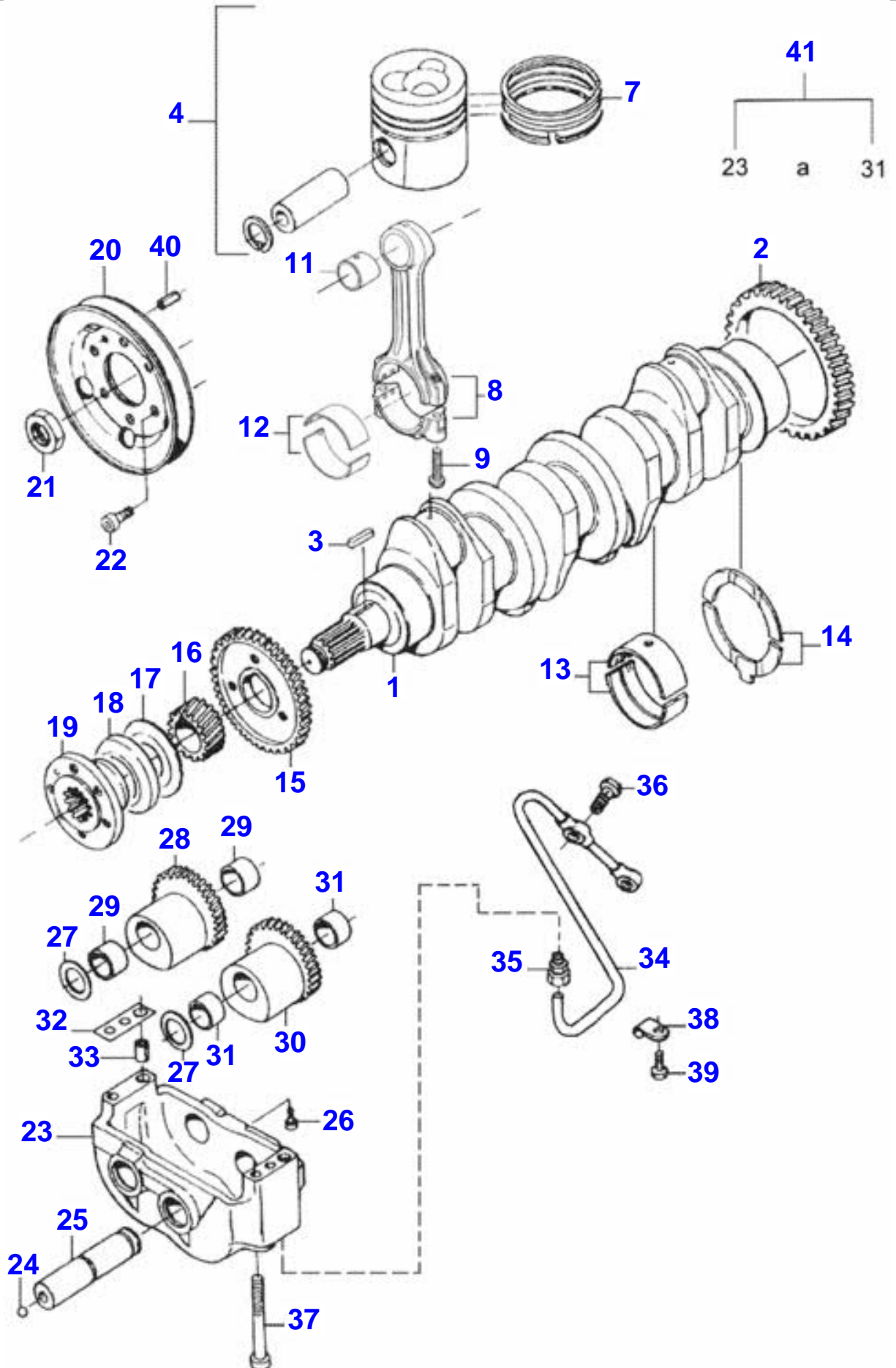

Item	Part Number	Qty	Description
1	V836747324	1	Crankshaft
2	V836124524	1	Gear
3	V603345110	1	Shifting
4	V836640073	4	Complete piston
7	V836640078	4	Piston ring set
8	V82659800	1	Connecting rod 4 cylinders Kit
9	V836864141	8	Screw
11	V836646271	4	Bushing
12	V836110552	4	Big-end bearing STD
	V836112762	4	Big-end bearing 0,25 mm
	V836112763	4	Big-end bearing 0,50 mm
	V836112767	4	Big-end bearing 1,50 mm
	V836112765	4	Big-end bearing 1,00 mm
13	V836655539	5	Main bearing 1,50mm
	V836655538	5	Main bearing 1,00mm
	V836655514	5	Big-end bearing STD
	V836655536	5	Main bearing 0,25mm
	V836655537	5	Main bearing 0,50mm
14	V836120332	2	Thrust washer
	V836120333	2	Thrust washer
	V836119459	2	Thrust washer Standard
15	V836119550	1	Gear
16	V836122840	1	Gear
17	V836129781	1	Ring
18	V836136271	1	Dust cover
19	V836846463	1	Hub
20	V836655449	1	Pulley
21	V836647310	1	Nut
22	V581804580	6	Screw
23	V836747348	1	Housing
24	V616810103	2	Ball
25	V836146879	2	Shaft
26	V581804200	2	Screw
27	V836146880	4	Washer
28	V836146877	1	Gear with counterweight Ref. 29
29	V836146876	2	Bushing
30	V836146878	1	Gear with counterweight Ref. 31
31	V836146876	2	Bushing
32	V836119920	-	Shim
33	V598359850	2	Pin
34	V836747298	1	Pipe
35	V641016008	1	Connection
36	V640435008	2	Banjo bolt
37	V581805170	4	Screw
38	V602071608	1	Clamp
39	VHA6313	1	Screw
40	V595953360	1	Pin
41	V836766123	1	Engine balancer - complete Ref. 23 a 31

BM110 TRACTOR (BRAZIL)

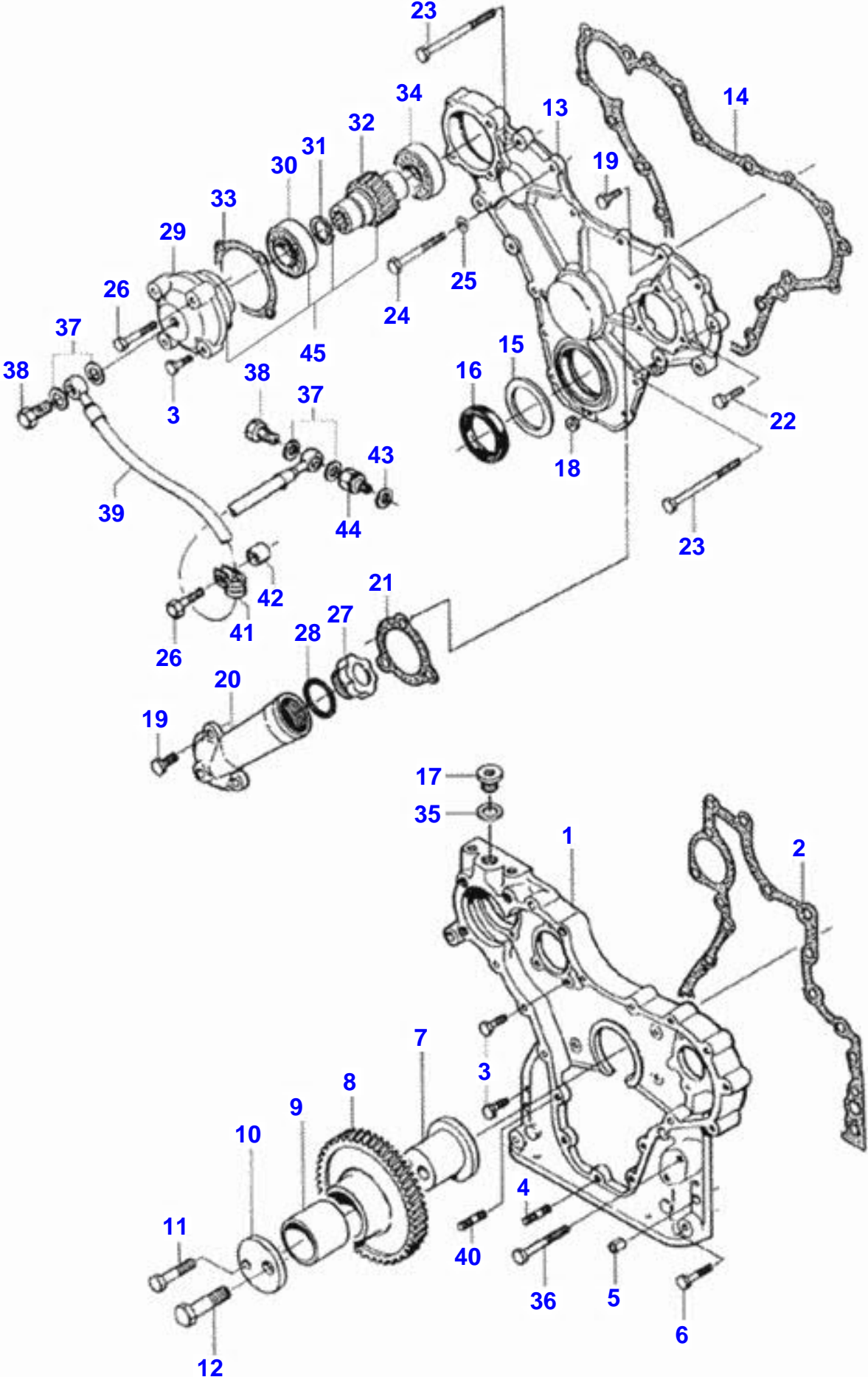

Item	Part Number	Qty	Description
1	V836652221	1	Gear housing
2	V836647419	1	Gasket gear housing
3	VHA6324	10	Screw
4	V546801380	5	Stud bolt
5	VJE8802	4	Pin
6	V529801440	2	Screw
7	V836138356	1	Shaft
8	V836138354	1	Gear assy
9	V836139039	1	Bushing
10	V836129845	1	Washer
11	V529801910	1	Screw
12	V529902720	1	Screw
13	V836647575	1	Cover
14	V835336796	1	Gasket front cover
15	V836129782	1	Shield ring
16	V614105880	1	Oil seal, crankshaft
17	V640325018	1	Plug
18	VJB1108	5	Nut
19	V528801380	5	Screw
20	V836746921	1	Pipe
21	V836129946	1	Gasket front cover
22	VHA9230	3	Screw
23	V529801500	2	Screw
24	VHA8328	3	Screw
25	V836120989	1	Washer
26	V529801460	3	Screw
27	V836338733	1	Cover
28	V614604740	1	O-ring, oil cap
29	V836655230	1	Bearing housing
30	VLA1014	1	Bearing
31	VKG3031	1	Circlip
32	V836122843	1	Shaft
33	V835336793	1	Gasket, bearing cover
34	VLA1014	1	Bearing
35	V615881822	1	Support of the seal
36	VHA8327	1	Screw
37	V615870610	4	Seal washer
38	V82619400	2	Banjo bolt
39	V82607600	1	Hose
40	V546801410	1	Stud bolt
41	V602060612	1	Clamp
42	V836119296	1	Spacer
43	V615571014	1	Seal ring
44	V836655233	1	Connection
45	V836647725	1	Bearing housing assy Ref. 29, 30, 31 e 32

Thank you so much for reading.
Please click the “Buy Now!”
button below to download the
complete manual.



After you pay.

You can download the most
perfect and complete manual in
the world immediately.

Our support email:

ebooklibonline@outlook.com