

Page Number	Page Title	Page Reference
01-000-TOC	ENGINE, FUEL AND EXHAUST SYSTEM	01-000-TOC
02-000-TOC	AXLES	02-000-TOC
03-000-TOC	STEERING SYSTEM	03-000-TOC
04-000-TOC	DRIVE TRAIN SYSTEM	04-000-TOC
05-000-TOC	BRAKE SYSTEM	05-000-TOC
06-000-TOC	HYDRAULIC SYSTEM	06-000-TOC
07-000-TOC	ELECTRICAL SYSTEM	07-000-TOC
08-000-TOC	CAB	08-000-TOC
09-000-TOC	AIR CONDITIONING AND HEATING SYSTEM	09-000-TOC
10-000-TOC	CHASSIS	10-000-TOC
11-000-TOC	DECALS	11-000-TOC
12-000-TOC	WHEELS	12-000-TOC
13-000-TOC	IMPLEMENT DRIVE SYSTEM	13-000-TOC
14-000-TOC	IMPLEMENT LIFT SYSTEM REAR	14-000-TOC
15-000-TOC	FRONT/REAR LOADERS	15-000-TOC
16-000-TOC	PRECISION FARMING SYSTEMS	16-000-TOC
17-000-TOC	ATTACHMENTS	17-000-TOC
18-000-TOC	GENERAL INFORMATION	18-000-TOC

Page Number	Page Title	Page Reference
01-0001	CYLINDERBLOCK	21-02
01-0002	FLYWHEEL AND HOUSING	21-04
01-0003	CYLINDER HEAD	21-06
01-0004	VALVE MECHANISM	21-08
01-0005	CRANK MECHANISM	21-10
01-0006	GEAR HOUSING	21-12
01-0007	OIL FILTER	21-14
01-0008	OIL SUMP	21-16
01-0009	AIR CLEANER	21-18
01-0010	INTAKE- AND EXHAUST PIPE	21-20
01-0011	MUFFLER	21-22
01-0012	TURBOCHARGER	21-24
01-0013	COLD-STARTING DEVICE	21-26
01-0014	FUEL FILTER	22-02
01-0015	FUEL PIPES	22-04
01-0016	INJECTION PUMP	22-06
01-0017	SPEED LEVERS	22-08
01-0018	RADIATOR	23-02
01-0019	COOLANT PUMP	23-04
	-K6506(M)	
01-0020	COOLANT PUMP	23-06
	K6507-(M)	
01-0021	STARTERMOTOR	31-02
01-0022	ALTERNATOR	31-04
01-0023	ALTERNATOR	31-06
01-0024	ALTERNATOR	31-08
01-0025	GASKET SETS	28-02
01-0026	GASKET SETS	28-04
01-0027	ENGINE REPAIR KIT AND BEARING	28-06
01-0028	ADJUSTING PLATE FOR INJECTOR	28-08
01-0029	SHIELD COVER AIR CLEANER (OPTIONAL EQUIPMENT)	29-02
01-0030	ENGINE HEATER (OPTIONAL EQUIPMENT)	39-04

X100 TRACTOR (X SERIES)
SPIMG-007-21-02

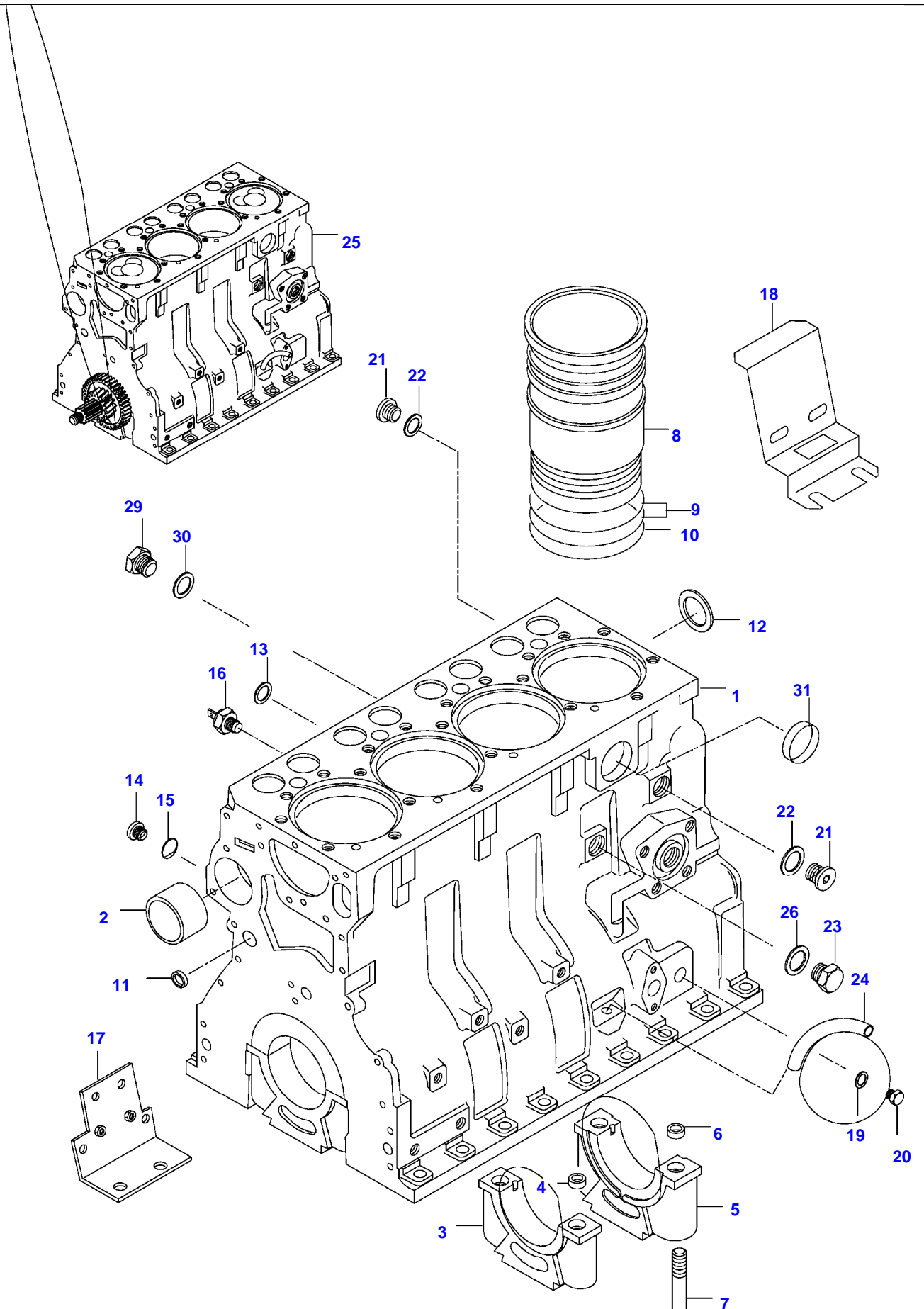

Item	Part Number	Qty	Description Comments	Technical Specification
1	V836747170	1	CYLINDER-BLOCK	
2	V836322610	1	CAMSHAFT BEARING BUSHING	
3	NS	4	NON-SERVICEABLE PART	
4	V836214478	8	BEARING COVER GUIDE SLEEVE	
5	NS	1	NON-SERVICEABLE PART	
6	V836214478	2	BEARING COVER GUIDE SLEEVE	
7	V835329030	10	HEX CAP SCREW	
8	V836647420	4	LINER	
	V836647933		LINER FLANGE S=9.08	FLANGE HEIGHT + 0.05 MM
	V836647934		LINER FLANGE S=9.13	FLANGE HEIGHT + 0.10 MM
	V836647935		LINER FLANGE S=9.23	FLANGE HEIGHT + 0.15 MM
9	V836647502	8	CYLINDER LINER O-RING S2	
10	V836647503	4	CYLINDER LINER O-RING S2	
11	V640016016	4	CUP PLUG	
12	V836529872	1	PLUG	
13	V640016018	1	CUP PLUG	
14	V640325110	2	SCREW PLUG	
15	V615571014	2	SEALING WASHER S2	
16	V887283760	1	PRESSURE SWITCH	
17	V836647927	1	RETAINING PLATE LEFT	
	V836647926	1	RETAINING PLATE RIGHT	
18	V836755844	2	SUPPORT	
19	V615881216	1	SEALING WASHER S2	
20	V640305012	1	PLUG	
21	V640325018	2	PLUG	
22	V615881822	2	SEALING WASHER	
23	V836019756	1	PLUG	
24	V836129747	1	OIL DIPSTICK GUIDE PIPE	
25	V862640001	1	REMANUFACTURED SHORT BLOCK ENGINE 420	
26	V615881824	1	SEALING WASHER S2	
29	V836119079	1	PLUG	
30	V615881620	1	SEALING WASHER	
31	V640016040	1	CUP PLUG	
	V836740280	1	ENGINE GASKET KIT S1	
	V836740974	1	ENGINE GASKET KIT S1+S2	

X100 TRACTOR (X SERIES)
SPIMG-007-21-04

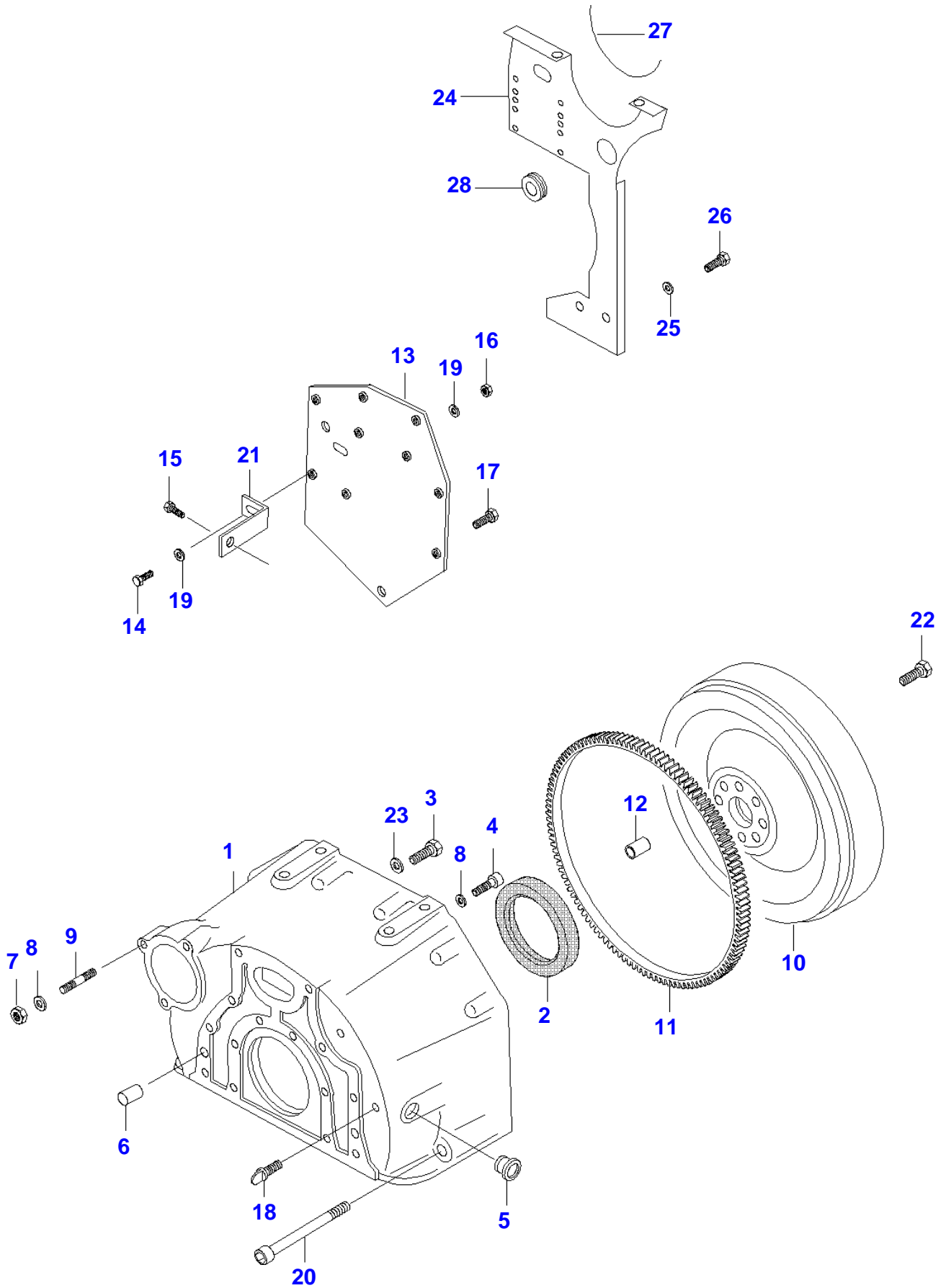

Item	Part Number	Qty	Description Comments	Technical Specification
1	V836647439	1	FLYWHEEL HOUSING	
2	V614500002	1	CRANKSHAFT SEAL S2	
3	V529702220	8	HEX CAP SCREW	
4	V581705030	6	HEX SOCKET SCREW	
5	V836007572	1	RUBBER PLUG	
6	V598359850	2	PIN	
7	V504601000	3	NUT	
8	V500951000	9	SPRING WASHER	
9	V546801800	3	STUD BOLT	
10	V836659990	1	FLYWHEEL SACHS	
	V836759820	1	FLYWHEEL HYDRAULIC CLUTCH	
11	V835328783	1	STARTER RING	
12	V836659527	1	GUIDE SLEEVE	
13	V836759798	1	BRACKET	
14	V528801362	1	HEX CAP SCREW	
15	V528801760	1	HEX CAP SCREW	
16	V504800800	1	NUT	
17	V528802180	1	HEX CAP SCREW	
18	V836859311	1	PLUG	
19	V500150842	2	WASHER	
20	VHC8519	2	HEX SOCKET SCREW	M12 X 140 DIN912 8.8
21	V836755361	1	SUPPORT	
22	V529702250	8	HEX CAP SCREW	
23	V500951200	8	SPRING WASHER	
24	V34172400	1	HOLDER	
25	VJD0408	2	WASHER	M8
26	VHA6322	2	SCREW	M8 X 16 SFS_EN_ISO_4017 8.8
27	V32604200	1	BAND	
28	ACV0799330	1	GROMMET	

X100 TRACTOR (X SERIES)
SPIMG-007-21-06

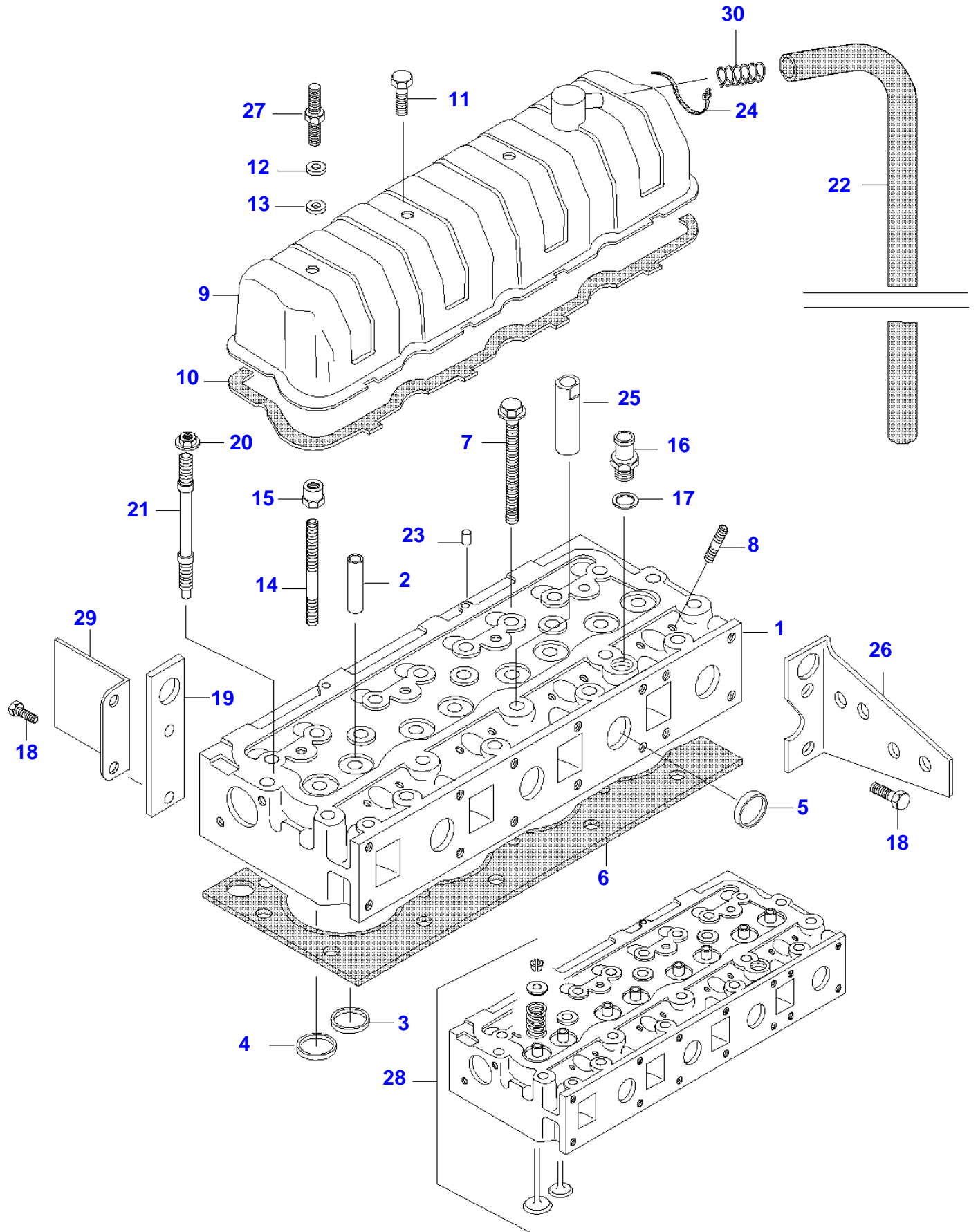

Item	Part Number	Qty	Description Comments
1	V836755383	1	CYLINDER
2	V836647601	8	GUIDE
3	V836647600	4	VALVE SEAT
5	V836647942	8	EXHAUST CUP PLUG
6	V836764156	1	CYLINDER HEAD GASKET S1
7	V836859104	21	HEXAGON FLANGE BOLT
8	V546901435	8	STUD BOLT
9	V836746361	1	VALVE ROCKER COVER
10	V836746362	1	VALVE ROCKER COVER GASKET S1
11	V528801780	3	HEX CAP SCREW
12	V836119855	4	WASHER
13	V836012841	4	RUBBER BUSHING S1
14	V546801900	4	STUD BOLT
15	V836655406	4	SLEEVE NUT
16	V836119837	1	HOSE COUPLER
17	V615881822	1	SEALING WASHER S1
18	V528801800	4	HEX CAP SCREW M10
19	V836855349	2	LIFT EYE
20	V836859110	3	NUT
21	V836859109	3	STUD BOLT
22	V836647814	1	RUBBER HOSE
23	V595959140	2	PIN
24	V835329746	1	CABLE TIE
25	V836647835	1	LIFTING EYE EXTENSION
27	V836659175	1	STUD BOLT
28	V836740854	1	CYLINDER HEAD
29	V836666199	1	HEAT SHIELD
30	V836659103	1	SPRING

X100 TRACTOR (X SERIES)
SPIMG-007-21-08

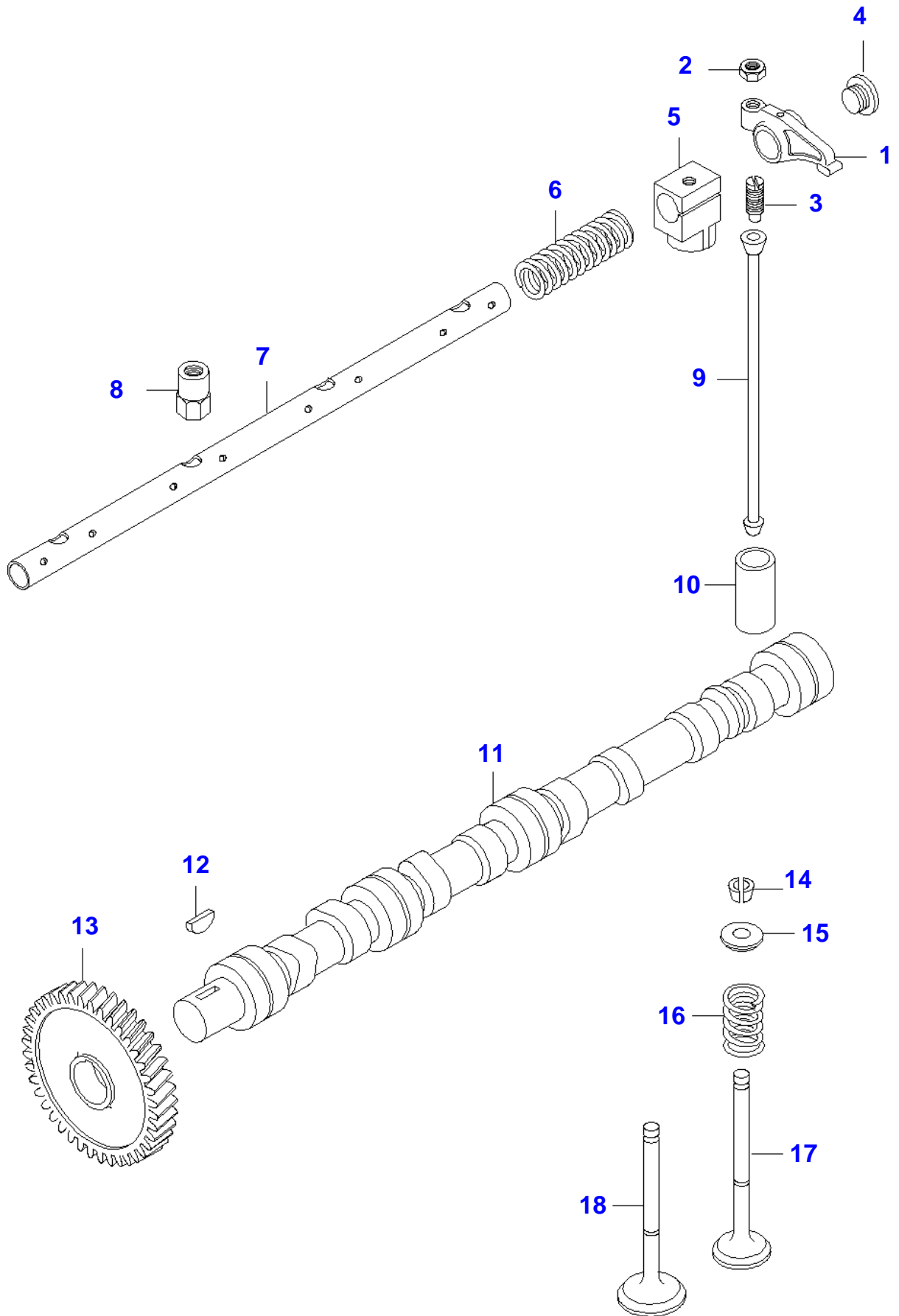

Item	Part Number	Qty	Description Comments
	V836755912	1	ROCKER SHAFT ASM
1	V836655873	8	ROCKER ARM
			.
2	V512861000	8	NUT
			..
3	V836655866	8	ADJUSTING SCREW
			..
4	V836655899	2	PLUG
			.
5	V836655869	4	BRACKET
			.
6	V836655884	3	SPRING
			.
7	V836755871	1	SHAFT
			.
8	V836655406	4	SLEEVE NUT
9	V836655867	8	PUSHROD
10	V836014264	8	TAPPET
11	V836746375	1	CAMSHAFT
12	V603305760	1	WOODRUFF KEY
13	V836646389	1	GEAR,CAMSHAFT
14	V836646382	16	COTTER
15	V836646381	8	WASHER
16	V836646380	8	SPRING
17	V836646357	4	EXHAUST VALVE
18	V836646356	4	INTAKE VALVE

X100 TRACTOR (X SERIES)
SPIMG-007-21-10

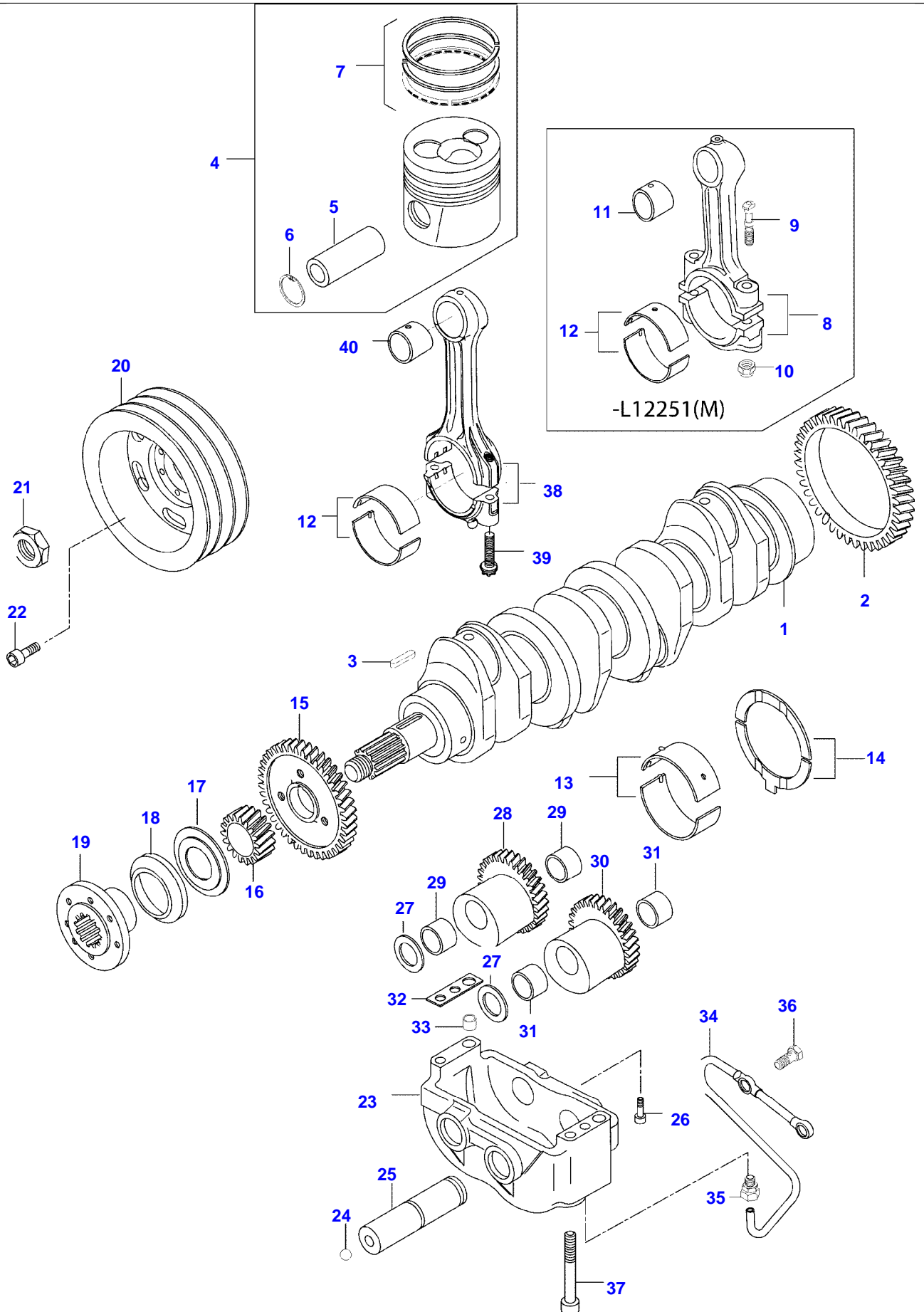

Item	Part Number	Qty	Description Comments	Technical Specification
1	V836747324	1	CRANKSHAFT	
2	V836124524	1	GEAR	
3	V603345110	1	KEY	
4	V836640073	4	PISTON	
5	NS	4	NON-SERVICEABLE PART	
6	NS	8	PISTON PIN NON-SERVICEABLE PART	
7	V836640078	4	CIRCLIP PISTON RING KIT	
8	V836647460	4	CONROD 2150-2169 G X -L12251(M)	
	V836652104		CONROD 2170-2189 G A -L12251(M)	
	V836652105		CONROD 2190-2209 G B -L12251(M)	
	V836652106		CONROD 2210-2229 G C -L12251(M)	
	V836652107		CONROD 2230-2249 G D -L12251(M)	
	V836652108		CONROD 2250-2269 G E -L12251(M)	
	V836652109		CONROD 2270-2289 G H -L12251(M)	
	V836652110		CONROD 2290-2309 G I -L12251(M)	
	V836652111		CONROD 2310-2329 G J -L12251(M)	
	V836652112		CONROD 2330-2349 G K -L12251(M)	
	V836652113		CONROD 2350-2369 G L -L12251(M)	
	V836652114		CONROD 2370-2389 G M -L12251(M)	
	V836652115		CONROD 2390-2409 G N -L12251(M)	
	V836652116		CONROD 2410-2429 G O -L12251(M)	
	V836652117		CONROD 2430-2449 G P -L12251(M)	
	V836652118		CONROD 2450-2469 G R -L12251(M)	
	V836652119		CONROD 2470-2489 G S -L12251(M)	

Item	Part Number	Qty	Description Comments	Technical Specification
	V836652120		CONROD 2490-2509 G T -L12251(M)	
	V836652121		CONROD 2510-2529 G U -L12251(M)	
38	V836666430		CONROD 1935-1954 G F L12252-(M)	
	V836666431		CONROD 1955-1974 G V L12252-(M)	
	V836666432		CONROD 1975-1994 G X L12252-(M)	
	V836666433		CONROD 1995-2014 G Y L12252-(M)	
	V836666434		CONROD 2015-2034 G W L12252-(M)	
	V836666435		CONROD 2035-2054 G Z L12252-(M)	
	V836666436		CONROD 2055-2074 G G L12252-(M)	
9	V836646204	8	CONNECTING ROD BOLT . -L12251(M)	
39	V836864141	8	CONNECTING ROD BOLT . L12252-(M)	
10	V836646205	8	NUT . -L12251(M)	
11	V836646271	4	BEARING BUSH . -L12251(M)	
40	V836110646	4	BEARING BUSH . L12252-(M)	STD
12	V836110552	4	BEARING SHELL SEE PAGE 01-0027	
13	V836655514	5	MAIN BEARING SEE PAGE 01-0027	
14	V836119459	2	THRUST WASHER SEE PAGE 01-0027	
15	V836119550	1	GEAR,CRANKSHAFT	
16	V836122840	1	GEAR,CRANKSHAFT	
17	V836129781	1	RING	
18	V836136271	1	SHIELD	
19	V836846463	1	CRANKSHAFT HUB	
20	V836655534	1	CRANKSHAFT V-BELT PULLEY	
21	V836647310	1	CRANKSHAFT NUT	
22	V581804600	6	HEX SOCKET SCREW	
23	V836747349	1	BALANCER -L10351 (M)	
	V836766123	1	COUNTERWEIGHT L10352- (M)	
24	V616810103	2	BALL . SHAFT	
25	V836146879	2	SHAFT . HEX SOCKET SCREW	
26	V581804200	2	HEX SOCKET SCREW .	

Item	Part Number	Qty	Description Comments	Technical Specification
27	V836146880	4	THRUST WASHER	
28	V836146877	1	GEAR	
	V836766121	1	COUNTERWEIGHT	
29	V836146876	2	BEARING BUSH	
30	V836146878	1	GEAR	
	V836766122	1	COUNTERWEIGHT	
31	V836146876	2	BEARING BUSH	
32	V836119920		SHIM	
33	V598359850	2	PIN	
34	V836747298	1	OIL PIPE	
35	V641016008	1	STRAIGHT FITTING	
36	V640435008	2	BANJO BOLT	
37	V581805170	4	HEX SOCKET SCREW	

X100 TRACTOR (X SERIES)
SPIMG-007-21-12

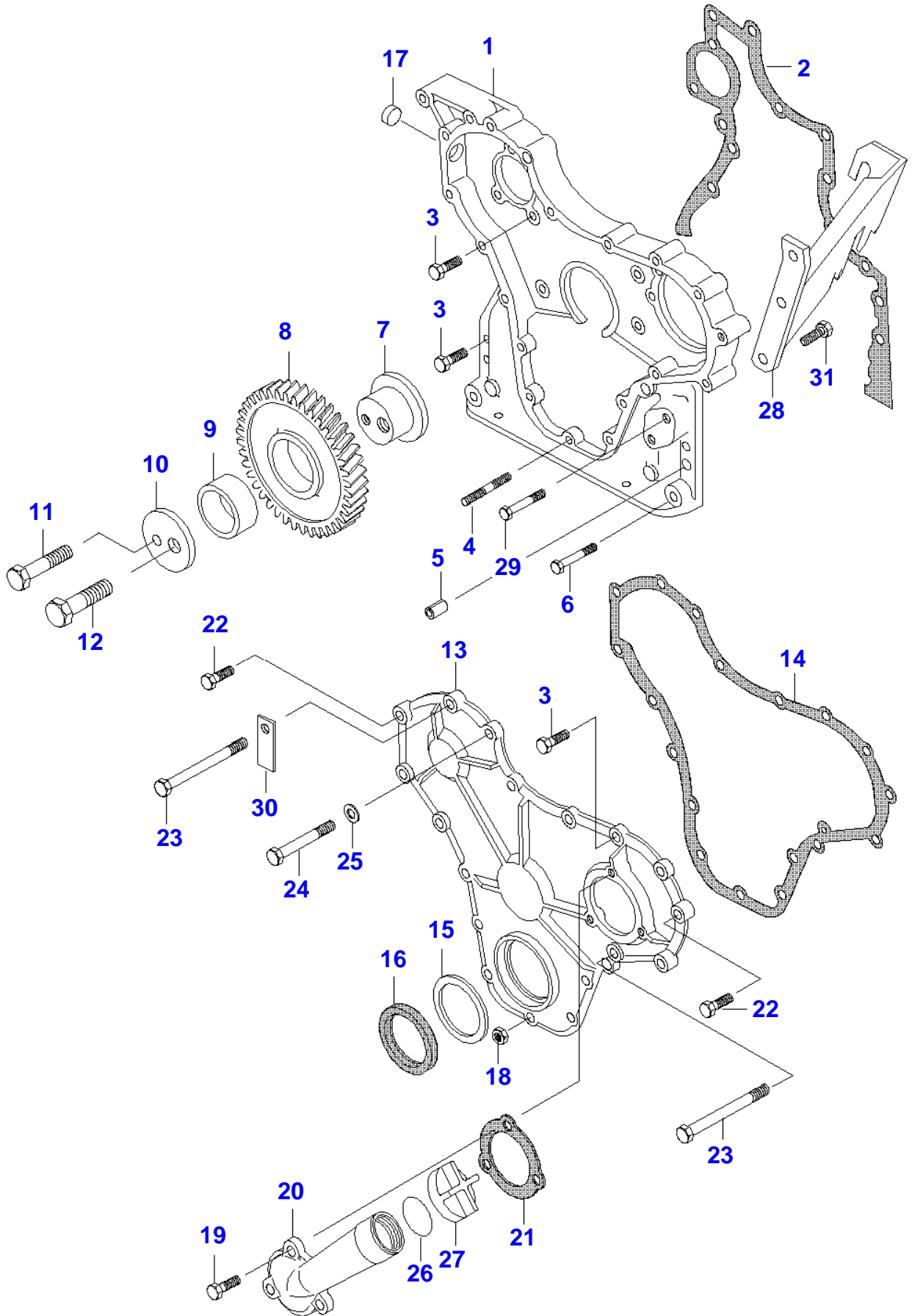

Item	Part Number	Qty	Description Comments
1	V836647865	1	TIMING GEAR CASE
2	V836647419	1	GASKET S2
3	V528801400	11	HEX CAP SCREW
4	V546801380	4	STUD BOLT
5	V598359850	4	PIN
6	V529801440	2	HEX CAP SCREW
7	V836129709	1	SHAFT
8	V836129863	1	IDLER GEAR
9	V836129844	1	BEARING BUSH
10	V836129845	1	FLANGE
11	V528801860	1	HEX CAP SCREW
12	V529902680	1	HEX CAP SCREW
13	V836647572	1	GEAR HOUSING FRONT COVER
14	V836129942	1	GASKET S2
15	V836129782	1	COVER
16	V614105880	1	OIL SEAL S2
17	V640016016	1	CUP PLUG
18	V504800800	5	NUT
19	V528801380	3	HEX CAP SCREW
20	V836746921	1	PIPE
21	V836129946	1	GASKET S2
22	V528801420	4	HEX CAP SCREW
23	V529801500	2	HEX CAP SCREW
24	V529801470	3	HEX CAP SCREW
25	V836120989	1	WASHER
26	V614604740	1	O-RING S2
27	V836338733	1	OIL FILLER CAP
28	V836659804	1	THROTTLE SENSOR BRACKET -K14472 (M)
	V836664528	1	THROTTLE SENSOR BRACKET K14473- (M)
29	V529801450	1	HEX CAP SCREW
30	V836083428	2	CABLE TIE
31	V528801362	2	HEX CAP SCREW

X100 TRACTOR (X SERIES)
SPIMG-007-21-14

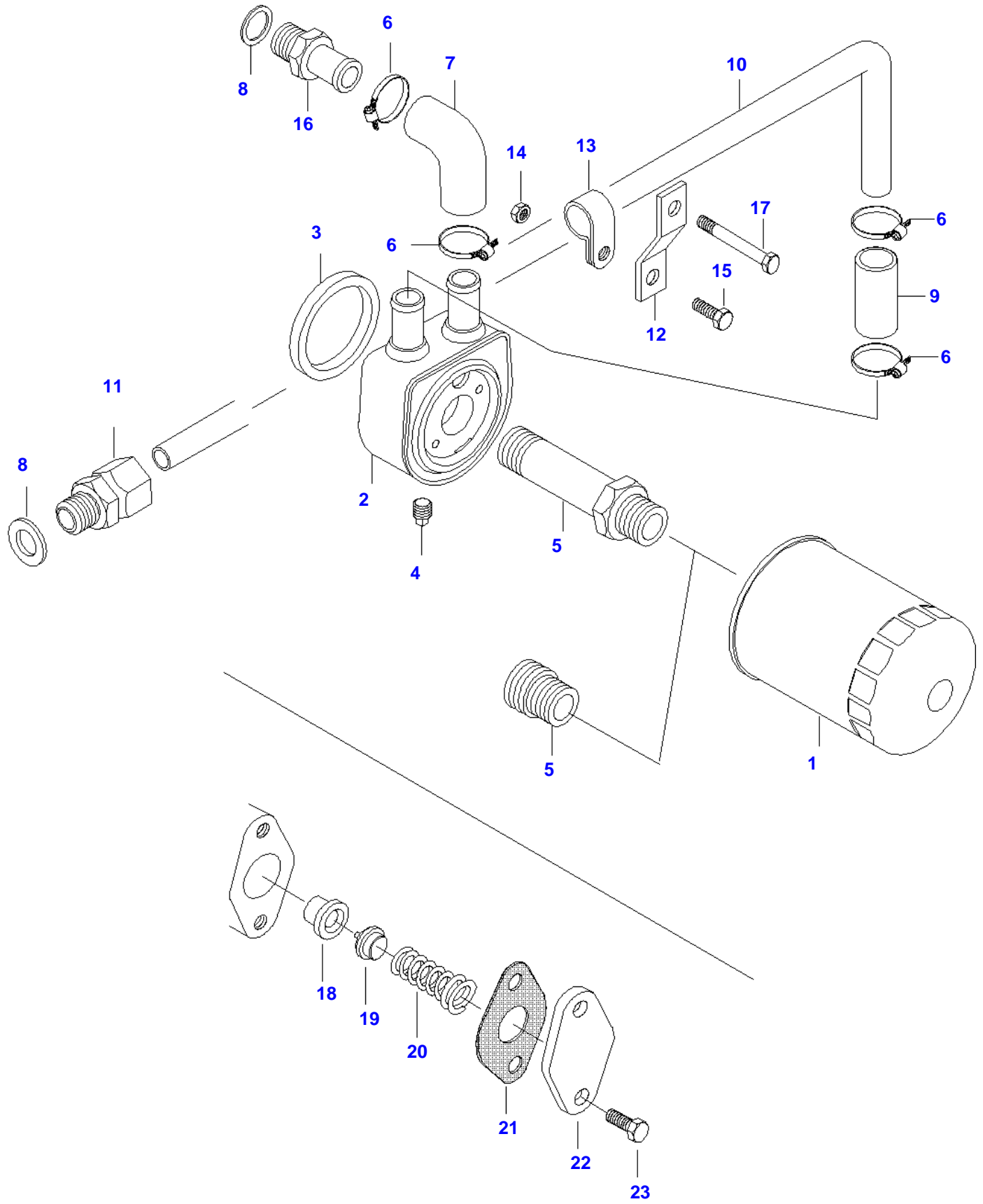

Item	Part Number	Qty	Description Comments
1	V20136342	1	OIL FILTER
3	V835331586	1	SEALING WASHER
4	V836131366	1	PLUG
5	V836647404	1	UNION
6	V602079516	4	HOSE CLIP
7	V836747124	1	RUBBER ELBOW
8	V615881822	2	SEALING WASHER S2
9	V836129978	1	RUBBER HOSE
13	V602060615	1	RETAINER CLAMP
14	V504800800	1	NUT
15	V528801380	1	HEX CAP SCREW
	V836662129	1	OIL PRESSURE CONTROL VALVE ASSEMBLY
18	V836659521	1	VALVE SEAT
19	V836659522	1	VALVE CONE
20	V836659523	1	SPRING
21	V836322190	1	GASKET
			S2
22	V836659524	1	COVER
23	V528801380	2	HEX CAP SCREW
			M8X20

X100 TRACTOR (X SERIES)
SPIMG-007-21-16

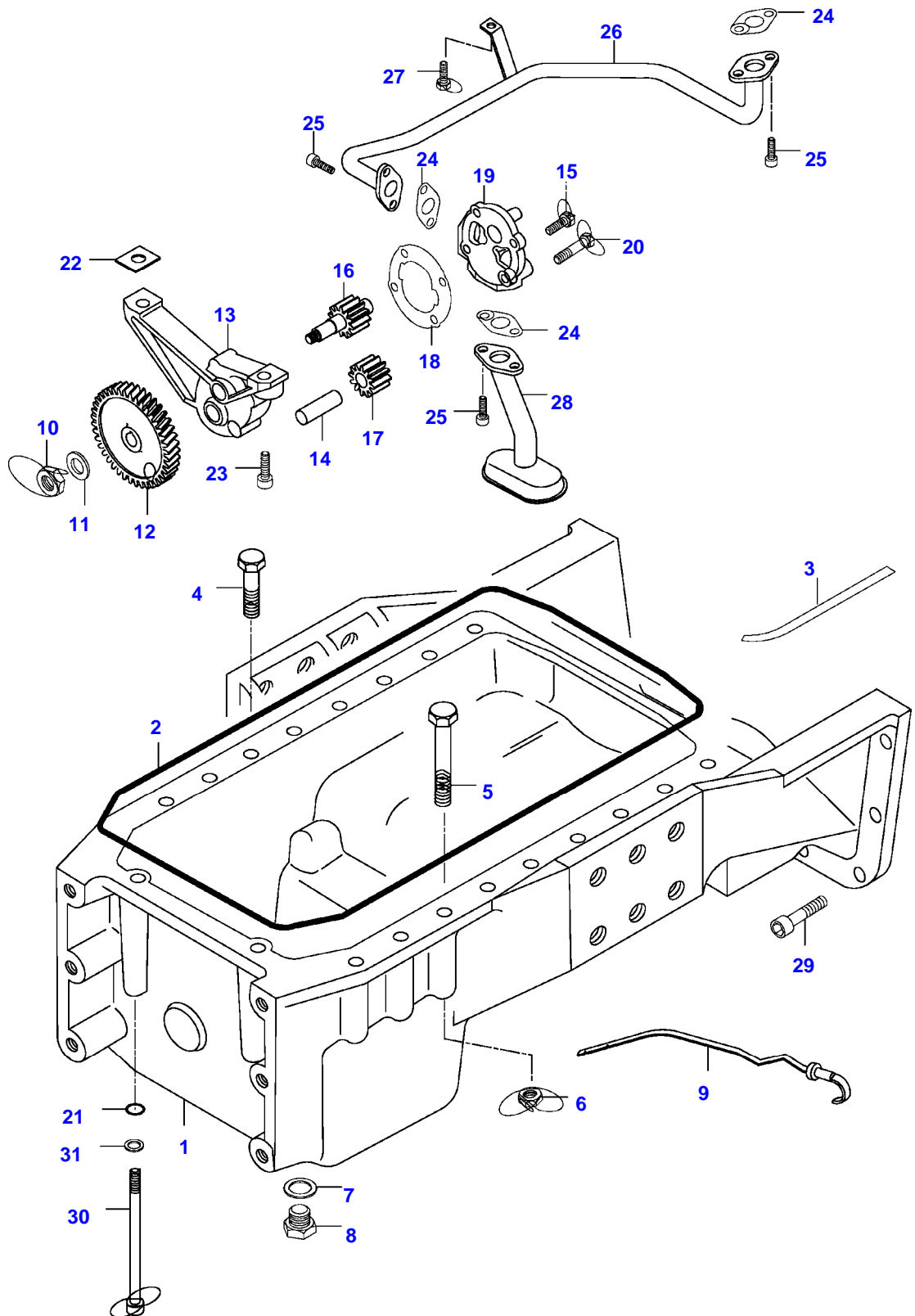

Item	Part Number	Qty	Description Comments	Technical Specification
1	V836146460	1	OIL SUMP	
2	V614756944	1	O-RING S2	
3	V836129727	2	GASKET S2	
4	V529702270	11	HEX CAP SCREW	
5	V529902390	7	HEX CAP SCREW	
6	V504801200	18	NUT	
7	V615881827	1	SEALING WASHER S2	
8	V836655493	1	PLUG	
9	V836129939	1	DIPSTICK	
	V836652605	1	LUBRICATING OIL PUMP	
10	V504861000	1	NUT	
11	V836122910	1	WASHER	
12	V836338667	1	GEAR	
13	V836120195	1	HOUSING	
14	V836120191	1	OIL PUMP SHAFT	
15	V528801380	2	HEX CAP SCREW	
16	V836652600	1	OIL PUMP SHAFT	
17	V836120193	1	GEAR	
18	V836119796	1	GASKET S2	
19	V836129412	1	COVER	
20	V529801440	2	HEX CAP SCREW	
21	V614600824	2	O-RING	
22	V836007871	1	SHIM	
23	V581805050	2	HEX SOCKET SCREW	
24	V836008449	3	GASKET S2	
25	V581804600	6	HEX SOCKET SCREW	
26	V836747561	1	KIT, PIPE	
27	V528801760	1	HEX CAP SCREW	
28	V836138033	1	AIR PIPE	
29	VHC9757	8	HEX SOCKET SCREW	M12 X 45 SFS_EN_ISO_4762 8.8
30	V581704800	2	HEX SOCKET SCREW	
31	V836120989	2	WASHER	

X100 TRACTOR (X SERIES)
SPIMG-007-21-18

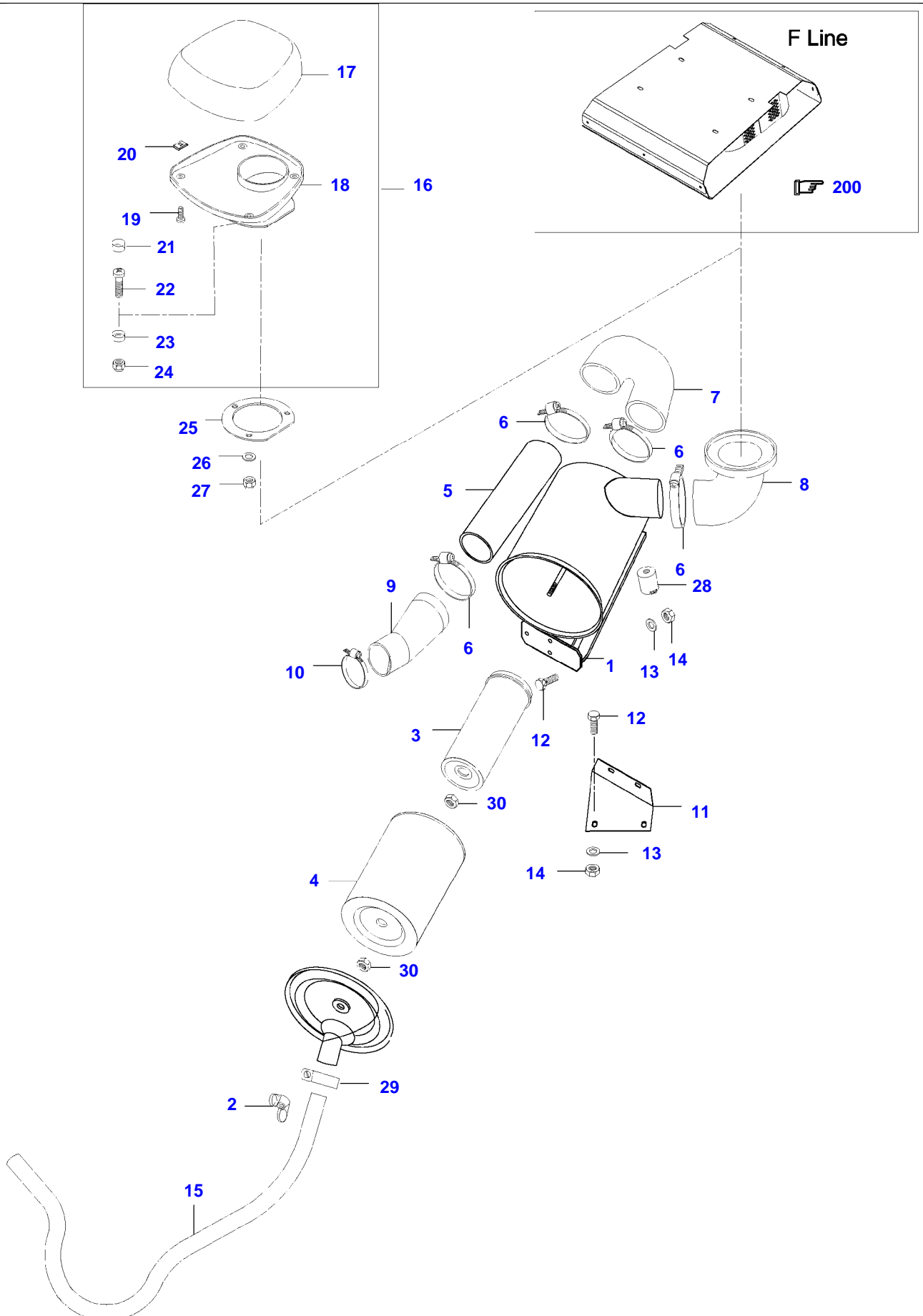

Item	Part Number	Qty	Description Comments	Technical Specification
	V33057500	1	AIR FILTER ASSEMBLY -K23221	D=225
	V33057510	1	AIR FILTER ASSEMBLY K23222-	D=225
1	NS	1	NON-SERVICEABLE PART . HOUSING	
30	VJB8905	2	LOCKNUT	M10 SFS_EN_ISO_10511
2	VJC1610	1	BLADE NUT	M10 DIN315 G5 ZNE
3	V20228410	1	FILTER ELEMENT	D=85 L=370
4	V20228310	1	AIR FILTER	D=165 L=380
5	V33031600	1	TUBE	
6	VGP3933	4	HOSE CLIP	D=95 SMS2298
7	V33031900	1	CURVED RUBBER	
8	V33032100	1	CURVED RUBBER	
9	V32999400	1	TUBE	
10	VGP3942	1	HOSE CLIP	D=75 SMS2298
11	V32952300	1	CARRIER	
12	VHA6323	7	SCREW	M8 X 20 CL8.8
13	VJD0408	7	WASHER	M8
14	VJB8904	7	NUT	M8
15	V33032800	1	HOSE	L=1250
16	V33042610	1	COVER ASSEMBLY	
17	V33051700	1	COVER	
18	V33045910	1	BOTTOM	
19	VHN6646	4	SCREW	B 4.8 X 13 SFS-ISO_7049
20	VJC9001	4	NUT	B 4.8 SFS:EN_ISO_1478
21	V32604400	3	CUP	M6
22	VHA6313	3	SCREW	M6 X 16 ISO 8.8
23	V32667000	3	RING WASHER	M6
24	VJB1106	3	NUT	M6 SFS-EN_ISO_4032
25	V33052610	1	GASKET	
26	VJD0406	3	WASHER	6.4 X 1.6 SFS-EN_ISO_7089
27	VJB8903	3	LOCKNUT	M6 SFS_EN_ISO_7042
28	V33389600	1	SENSOR	6.5 KPA
29	VGP3923	2	HOSE CLIP	D=44 SMS2298

X100 TRACTOR (X SERIES)
SPIMG-007-21-20

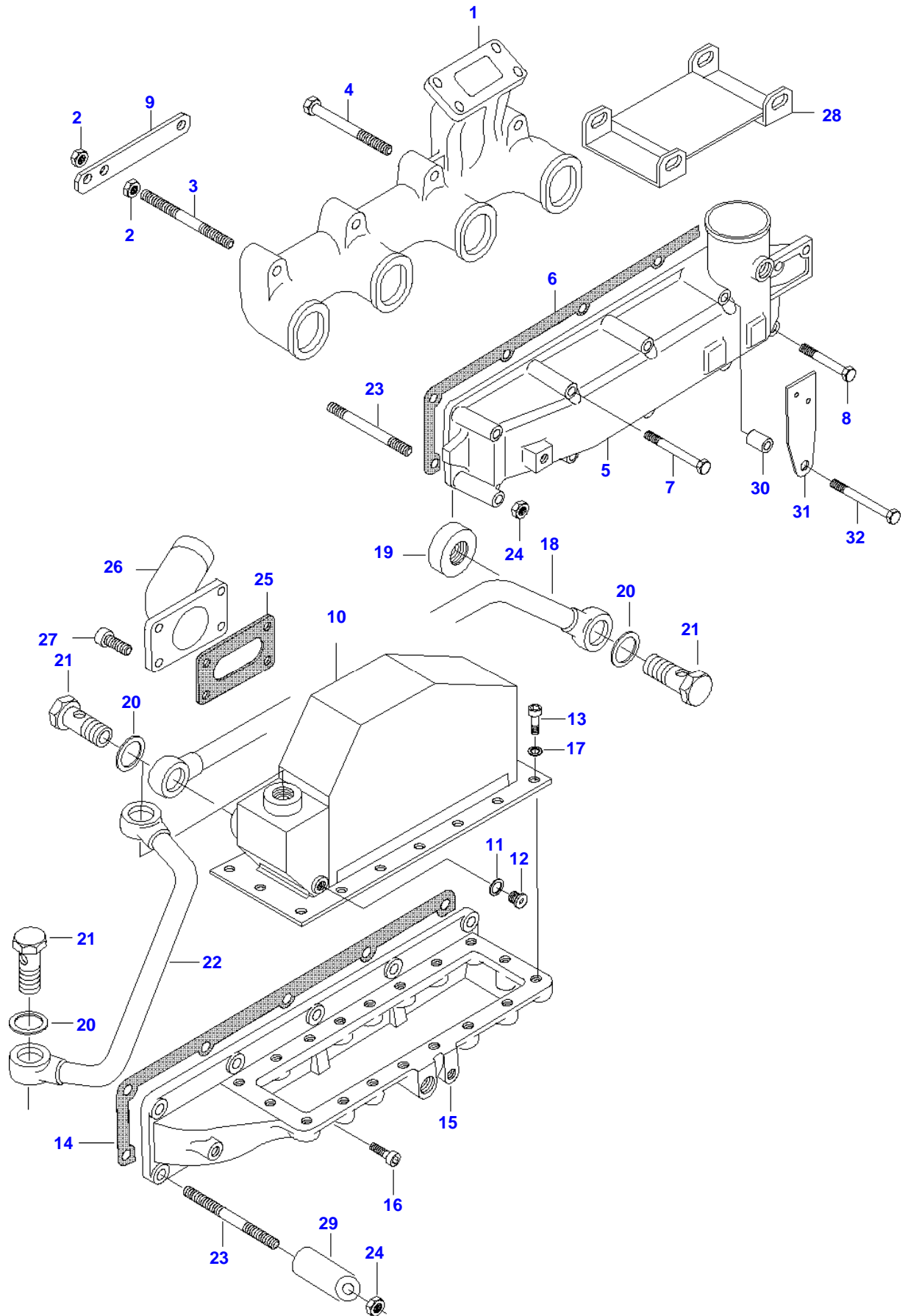

Item	Part Number	Qty	Description Comments
1	V836747524	1	EXHAUST MANIFOLD
2	V504601000	5	NUT
3	V546801960	3	STUD BOLT
4	V529801950	5	HEX CAP SCREW
5	V836747691	1	INTAKE MANIFOLD
6	V836747595	1	INTAKE MANIFOLD GASKET S1
7	V529801490	9	HEX CAP SCREW
8	V529801470	1	HEX CAP SCREW
9	V836755027	1	RETAINING PLATE
11	V615571014	1	SEALING WASHER
12	V640325110	1	SCREW PLUG
23	V546801510	1	STUD BOLT
24	V504800800	1	NUT
28	V836655735	1	HEAT SHIELD
30	V836114846	1	SPACER
31	V836664162	1	BRACKET
32	V529801550	1	HEX CAP SCREW

X100 TRACTOR (X SERIES)
SPIMG-007-21-22

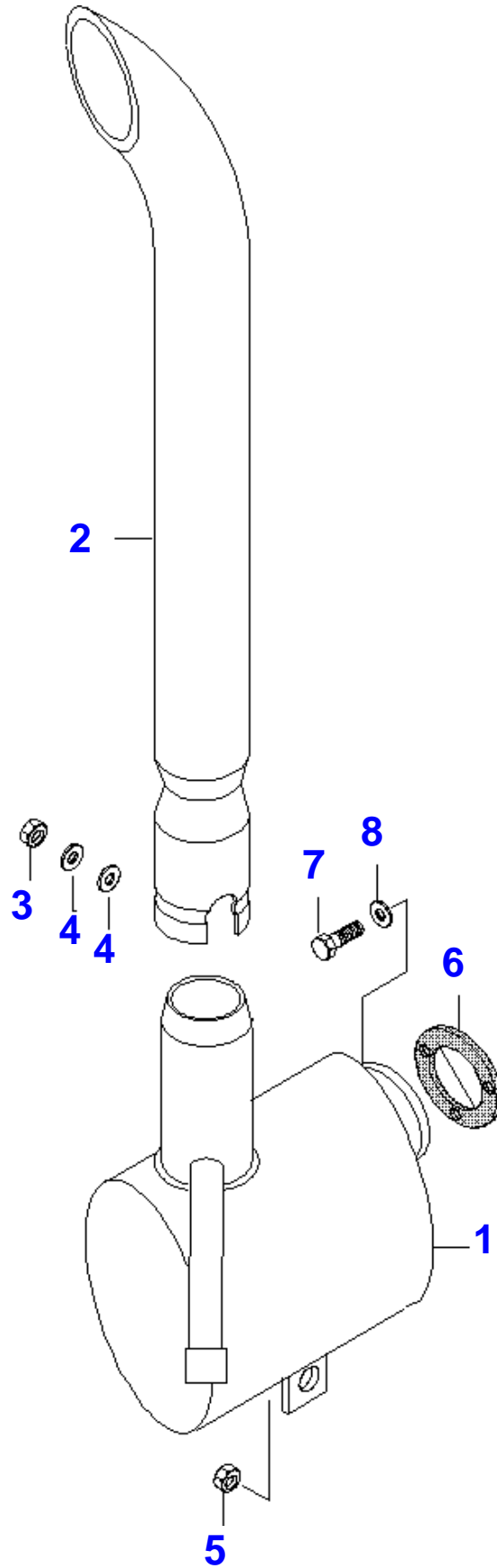

Thank you so much for reading.
Please click the “Buy Now!”
button below to download the
complete manual.



After you pay.

You can download the most
perfect and complete manual in
the world immediately.

Our support email:

ebooklibonline@outlook.com