

<b>Page Number</b>	<b>Page Title</b>	<b>Page Reference</b>
01-000-TOC	ENGINE, FUEL AND EXHAUST SYSTEM	01-000-TOC
02-000-TOC	AXLES	02-000-TOC
03-000-TOC	STEERING SYSTEM	03-000-TOC
04-000-TOC	DRIVE TRAIN SYSTEM	04-000-TOC
05-000-TOC	BRAKE SYSTEM	05-000-TOC
06-000-TOC	COMPRESSED AIR SYSTEM	06-000-TOC
07-000-TOC	HYDRAULIC SYSTEM	07-000-TOC
08-000-TOC	ELECTRICAL SYSTEM	08-000-TOC
09-000-TOC	CAB	09-000-TOC
10-000-TOC	AIR CONDITIONING AND HEATING SYSTEM	10-000-TOC
11-000-TOC	CHASSIS	11-000-TOC
12-000-TOC	DECALS	12-000-TOC
13-000-TOC	WHEELS	13-000-TOC
14-000-TOC	IMPLEMENT DRIVE SYSTEM	14-000-TOC
15-000-TOC	IMPLEMENT LIFT SYSTEM FRONT	15-000-TOC
16-000-TOC	IMPLEMENT LIFT SYSTEM REAR	16-000-TOC
17-000-TOC	FRONT/REAR LOADERS	17-000-TOC
18-000-TOC	ATTACHMENTS	18-000-TOC
19-000-TOC	GENERAL INFORMATION	19-000-TOC

Page Number	Page Title	Page Reference
01-0001	CYLINDERBLOCK	21-02
01-0002	FLYWHEEL AND HOUSING	21-04
01-0003	CYLINDER HEAD	21-06
01-0004	VALVE MECHANISM	21-08
01-0005	CRANK MECHANISM	21-10
01-0006	BALANCER WEIGHT	21-12
01-0007	GEAR HOUSING	21-14
01-0008	OIL FILTER	21-16
01-0009	OIL SUMP	21-18
01-0010	AIR CLEANER	21-20
01-0011	INTAKE- AND EXHAUST PIPE	21-22
01-0012	AIR INTAKE SYSTEM	21-24
01-0013	PILLAR EXHAUST PIPE	21-26
01-0014	TURBOCHARGER	21-28
01-0015	FUEL FILTER	22-02
01-0016	INJECTION PUMP	22-04
01-0017	SPEED LEVERS	22-08
01-0018	RADIATOR	23-02
01-0019	COOLANT PUMP	23-04
01-0020	STARTERMOTOR	24-02
01-0021	ALTERNATOR	24-04
01-0022	WIRING SET, ENGINE	24-06
01-0023	GASKET SETS	28-02
01-0024	ENGINE REPAIR KIT AND BEARING	28-04
01-0025	ADJUSTING PLATE FOR INJECTOR	28-06
01-0026	ENGINE HEATER (OPTIONAL EQUIPMENT)	29-08

C100 TRACTOR (C SERIES)  
SPIMG-012-21-02

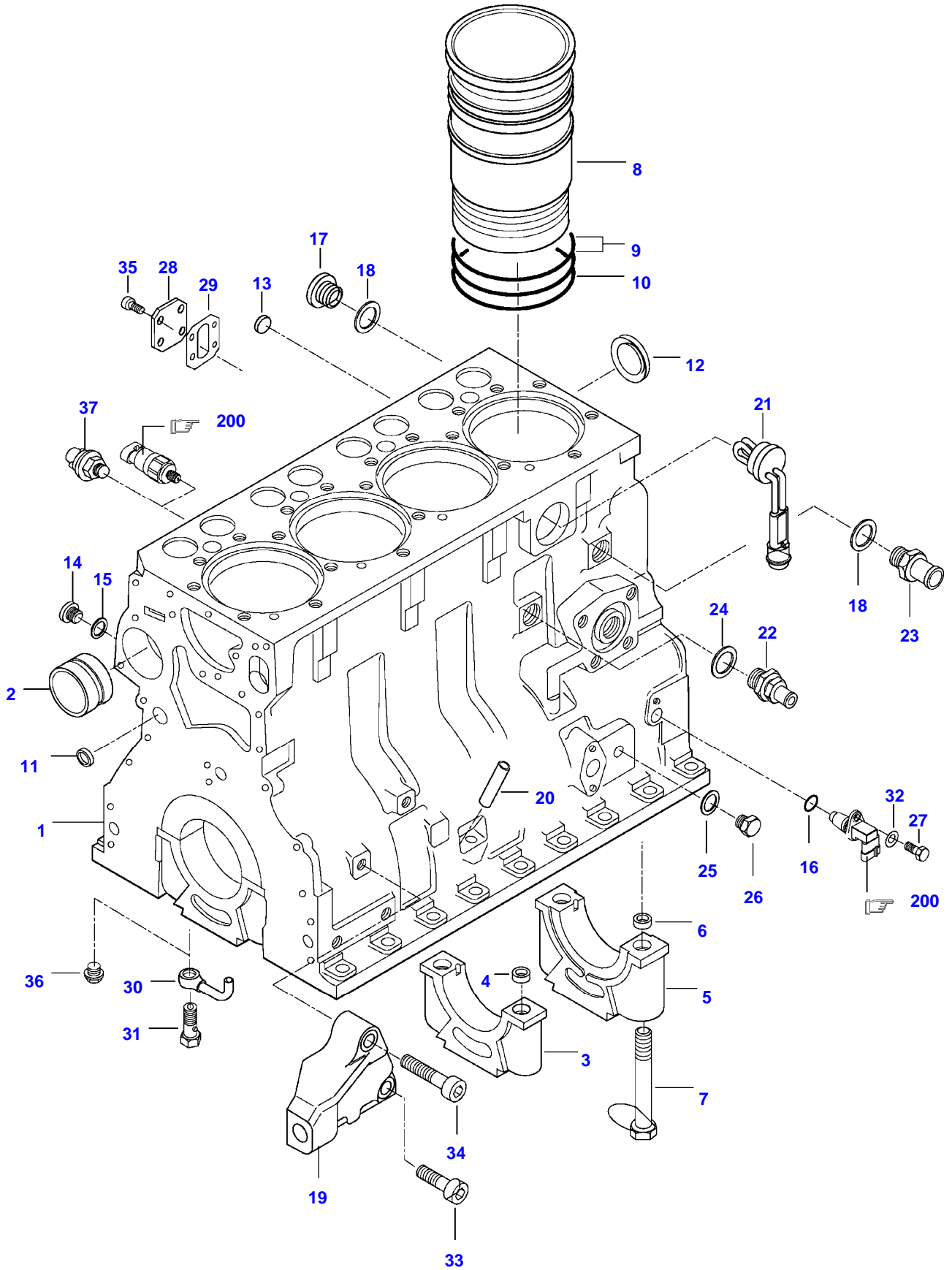

Item	Part Number	Qty	Description Comments
1	V836766377	1	CYLINDER BLOCK
2	V836866069	1	CAMSHAFT BEARING BUSHING
3	NS	4	NON-SERVICEABLE PART
4	V836214478	8	BEARING COVER GUIDE SLEEVE
5	NS	1	NON-SERVICEABLE PART
6	V836214478	2	BEARING COVER GUIDE SLEEVE
7	V835329030	10	HEX CAP SCREW
8	V836666990	4	LINER
9	V836647502	8	CYLINDER LINER O-RING S2
10	V836647503	4	CYLINDER LINER O-RING S2
11	V640016016	4	CUP PLUG S2
12	V836529872	1	PLUG
13	V640016018	1	CUP PLUG
14	V640325110	2	SCREW PLUG
15	V615571014	2	SEALING WASHER S2
16	V614601524	1	O-RING
17	V640325018	1	PLUG
18	V615881822	2	SEALING WASHER S2
19	V836766159	1	ENGINE MOUNT RIGHT
20	V836766160	1	ENGINE MOUNT LEFT
21	V836666910	1	OIL DIPSTICK GUIDE PIPE
21	V837070396	1	ENGINE BLOCK HEATER SEE PAGE 01-0026
22	V836664377	1	DRAIN VALVE
23	V836119837	1	HOSE COUPLER
24	V615881824	1	SEALING WASHER S2
25	V615881216	1	SEALING WASHER
26	V640305012	1	PLUG
27	V528801362	1	HEX CAP SCREW M8 X 16
28	V836866957	1	COVER
29	V836866958	1	GASKET S2
30	V836855093	4	OIL NOZZLE
31	V836338601	4	PRESSURE VALVE
32	V500050840	1	FLAT WASHER
33	V581705850	2	HEX SOCKET SCREW M14 X 40
34	V581705890	2	HEX SOCKET SCREW M14 X 60
35	V581804600	4	HEX SOCKET SCREW M8 X 20
36	V640045112	4	PLUG
37	V887283760	1	PRESSURE SWITCH
200			SEE PAGE 01-0022

C100 TRACTOR (C SERIES)  
SPIMG-012-21-04

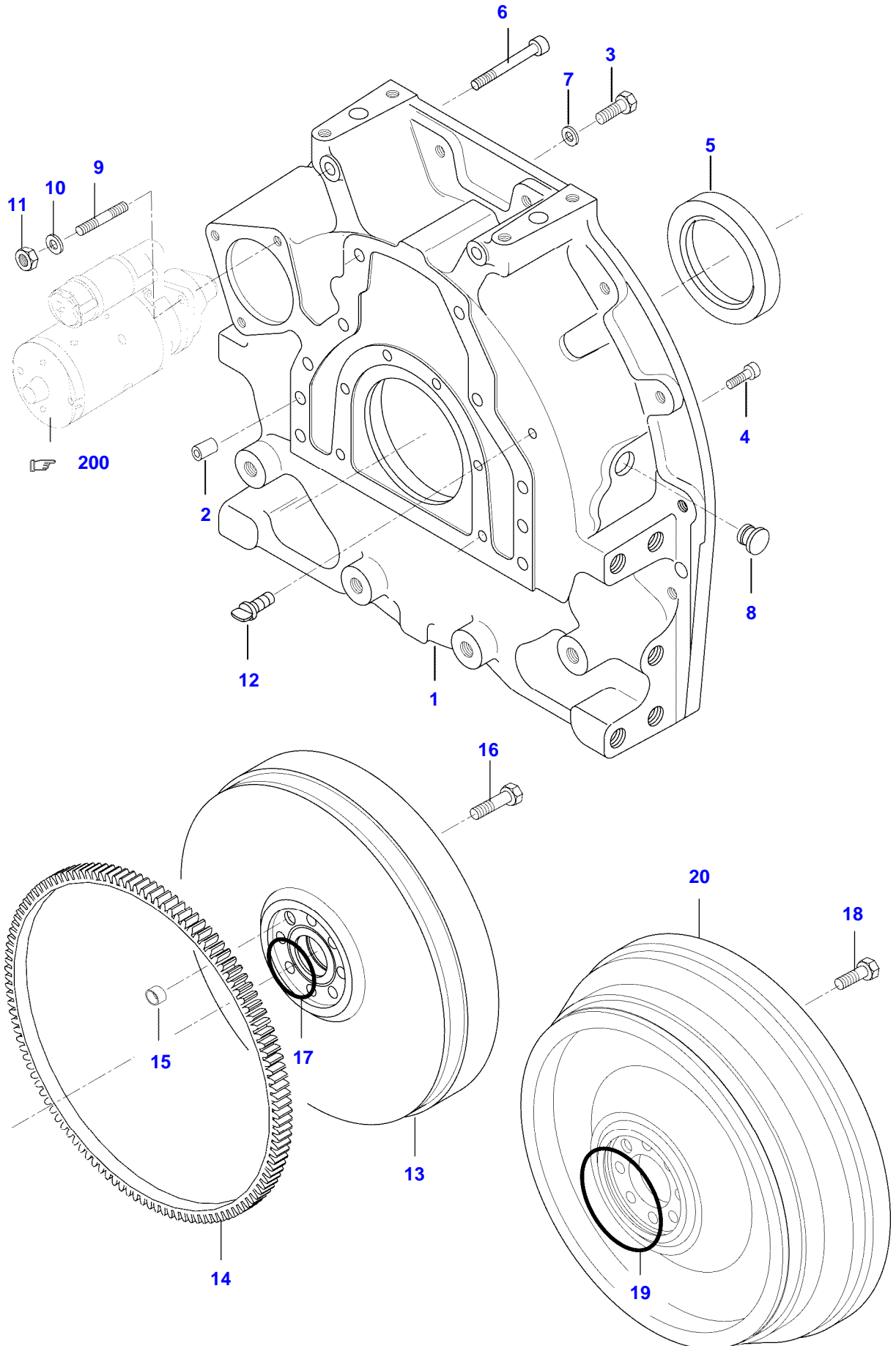

Item	Part Number	Qty	Description Comments
1	V836764330	1	FLYWHEEL HOUSING
2	V598359850	2	PIN
3	V529702220	8	HEX CAP SCREW M12 X 35
4	V581705030	6	HEX SOCKET SCREW M10 X 30
5	V614500002	1	CRANKSHAFT SEAL S2
6	V581705580	2	HEX SOCKET SCREW M12 X 110
7	V500951200	8	SPRING WASHER
8	V836007572	1	RUBBER PLUG
9	V546801800	3	STUD BOLT M10 X 25
10	V500951000	3	SPRING WASHER
11	V504601000	3	NUT M10
12	V836859311	1	PLUG
13	V836766274	1	FLYWHEEL
20	V836766185	1	FLYWHEEL HYDRAULIC CLUTCH
14	V835328783	1	STARTER RING
15	V836659527	1	GUIDE SLEEVE
16	V529702250	8	HEX CAP SCREW 150 NM
17	V614606230	1	O-RING
18	V528702230	8	HEX CAP SCREW 150 NM
19	V614610930	1	O-RING HYDRAULIC CLUTCH
200			SEE PAGE 01-0020

C100 TRACTOR (C SERIES)  
SPIMG-012-21-06

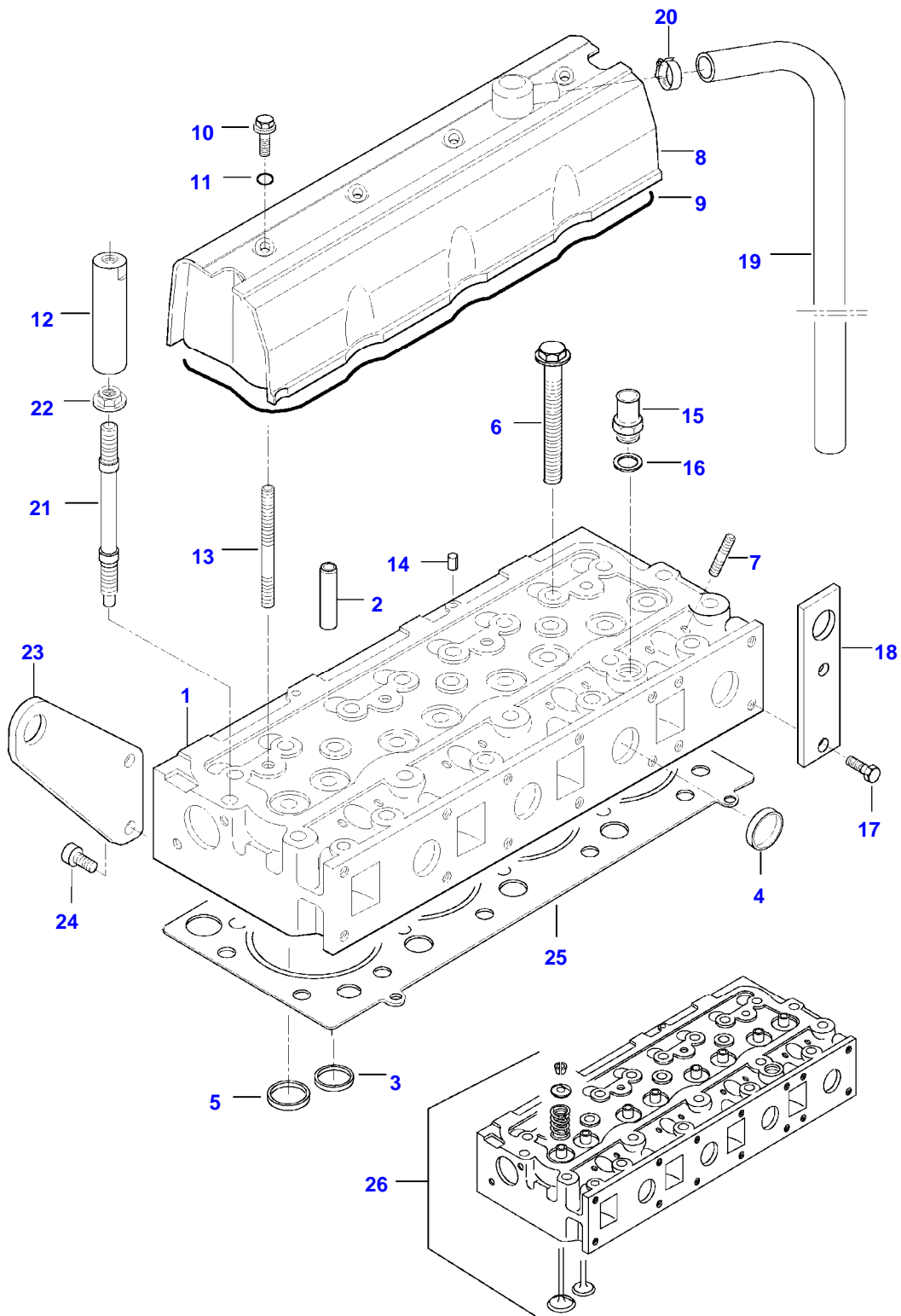

Item	Part Number	Qty	Description Comments
1	NS	1	NON-SERVICEABLE PART CYLINDER HEAD
2	V836647601	8	GUIDE
3	V836647600	4	VALVE SEAT
4	V836647942	8	EXHAUST CUP PLUG
6	V836859104	20	HEXAGON FLANGE BOLT
7	V546901435	8	STUD BOLT M8 X 40
8	V836767207	1	VALVE COVER
9	V614738740	1	COVER GASKET S1
10	V540801780	4	HEXAGON FLANGE BOLT
11	V614901030	4	O-RING S1
12	V836667062	1	LIFTING EYE EXTENSION
13	V546801900	4	STUD BOLT M10 X 75
14	V595959140	2	PIN
15	V836119837	1	HOSE COUPLER
16	V615881822	1	SEALING WASHER S1
17	V528801800	2	HEX CAP SCREW M10 X 25
18	V836855349	1	LIFT EYE
19	V836647814	1	RUBBER HOSE
20	V602088532	1	HOSE CLIP
21	V836859109	2	STUD BOLT
22	V836859110	2	NUT
23	V836667203	1	LIFT EYE
24	V581705000	2	HEX SOCKET SCREW M10 X 20
25	V837070291	1	CYLINDER HEAD GASKET S1
26	V836740869	1	CYLINDER HEAD



C100 TRACTOR (C SERIES)  
SPIMG-012-21-08

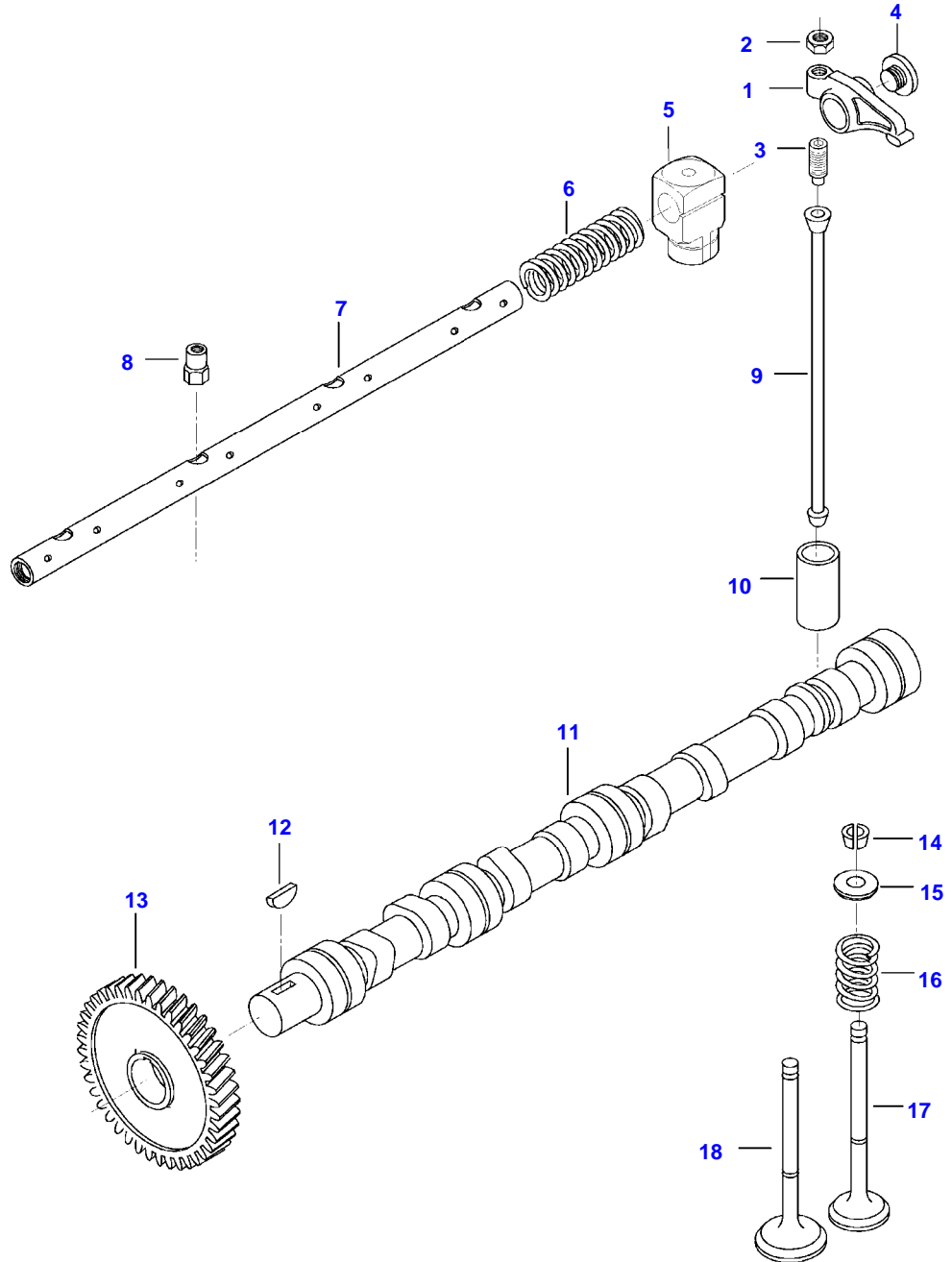

Item	Part Number	Qty	Description Comments
	V836767044	1	ROCKER SHAFT ASM ASSEMBLY
1	V836666608	8	ROCKER ARM . -S12222 (M)
	V836667042	8	ROCKER ARM . S12223- (M)
2	V512861000	8	NUT
3	V836655866	8	ADJUSTING SCREW .. -S12222 (M)
	V837069023	8	VALVE ROCKER ADJUSTMENT SCREW .. S12223- (M)
4	V836655899	2	PLUG . -S12222 (M)
	V837069020	2	PLUG . S12223- (M)
5	V836666609	4	BRACKET
6	V836655884	3	SPRING
7	V836755871	1	SHAFT . SLEEVE NUT
8	V836655406	4	SLEEVE NUT
9	V836655867	8	PUSHROD
10	V836014264	8	TAPPET
11	V836746375	1	CAMSHAFT
12	V603305760	1	WOODRUFF KEY
13	V836646389	1	GEAR,CAMSHAFT
14	V836646382	16	COTTER
15	V836646381	8	WASHER
16	V836646380	8	SPRING
17	V836646357	4	EXHAUST VALVE
18	V836646356	4	INTAKE VALVE

C100 TRACTOR (C SERIES)  
SPIMG-012-21-10

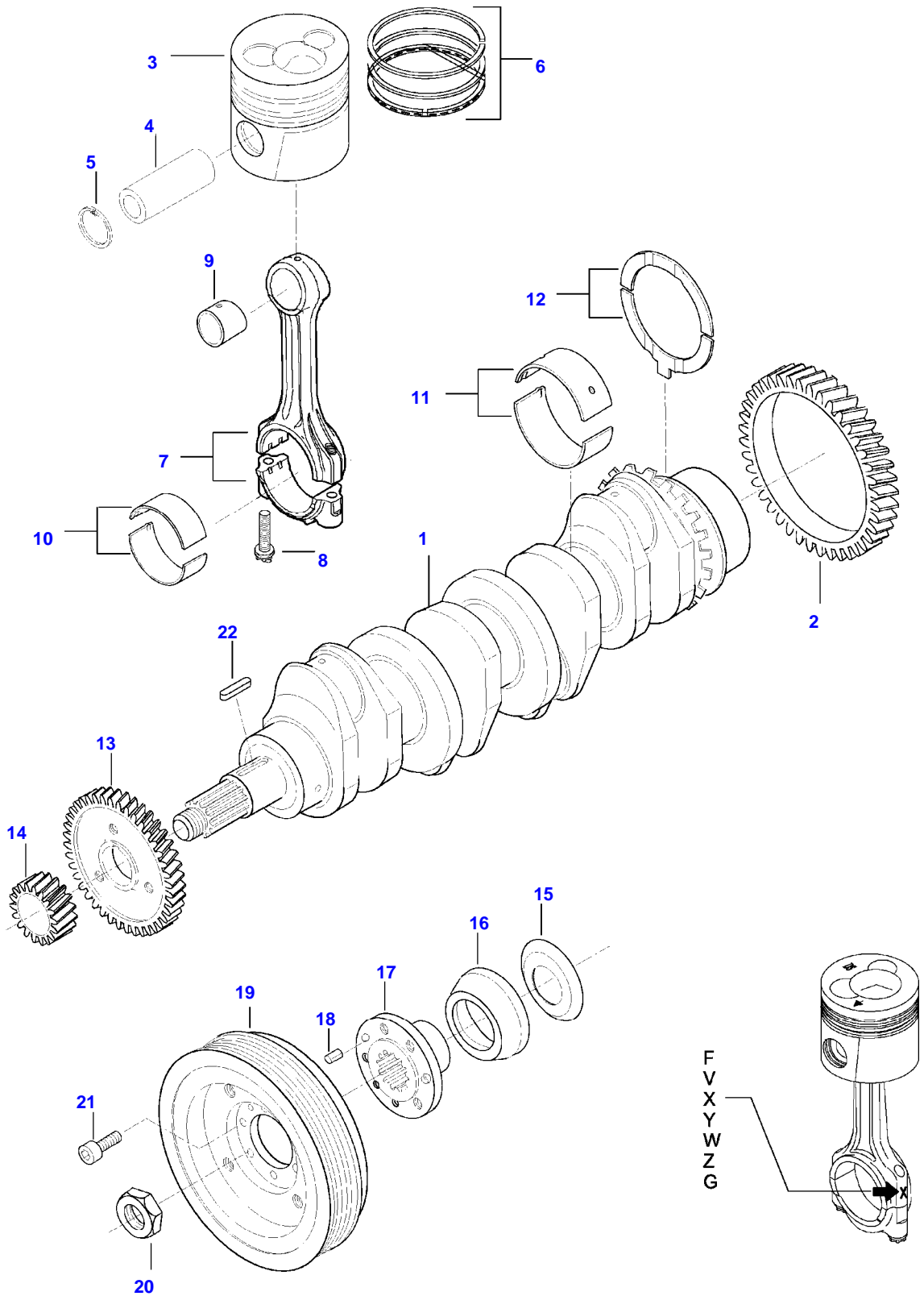

Item	Part Number	Qty	Description Comments	Technical Specification
1	V836747516	1	CRANKSHAFT	
2	V836124524	1	GEAR	
3	V836659702	4	PISTON	
4	NS	4	NON-SERVICEABLE PART	
5	NS	8	PISTON PIN NON-SERVICEABLE PART	
6	V836640126	4	CIRCLIP PISTON RING KIT	
4	NS	4	NON-SERVICEABLE PART	
5	NS	8	PISTON PIN NON-SERVICEABLE PART	
7	V836740859	6	CIRCLIP CONNECTING ROD KIT	
	NS	6	NON-SERVICEABLE PART	
	NS	6	CONNECTING ROD 11935-1954 G, F NON-SERVICEABLE PART	
	NS	6	CONNECTING ROD 11955-1974 G, V NON-SERVICEABLE PART	
	NS	6	CONNECTING ROD 11975-1994 G, X NON-SERVICEABLE PART	
	NS	6	CONNECTING ROD 11995-2014 G, Y NON-SERVICEABLE PART	
	NS	6	CONNECTING ROD 12015-2034 G, W NON-SERVICEABLE PART	
	NS	6	CONNECTING ROD 12035-2054 G, Z NON-SERVICEABLE PART	
8	V836864141	8	CONNECTING ROD 12055-2074 G, G CONNECTING ROD BOLT	
9	V836110646	4	BEARING BUSH	STD
10	V836110552	4	BEARING SHELL	
11	V836655514	5	MAIN BEARING	
12	V836119459	2	THRUST WASHER	
13	V836119550	1	GEAR,CRANKSHAFT	
14	V836122840	1	GEAR,CRANKSHAFT	
15	V836129781	1	RING	
16	V836136271	1	SHIELD	
17	V836846463	1	CRANKSHAFT HUB	
18	V595953360	1	PIN	
19	V836766988	1	CRANKSHAFT PULLEY	
20	V836647310	1	CRANKSHAFT NUT	
21	V581804600	6	HEX SOCKET SCREW M8 X 20	
22	V603345110	1	KEY	

C100 TRACTOR (C SERIES)  
SPIMG-012-21-12

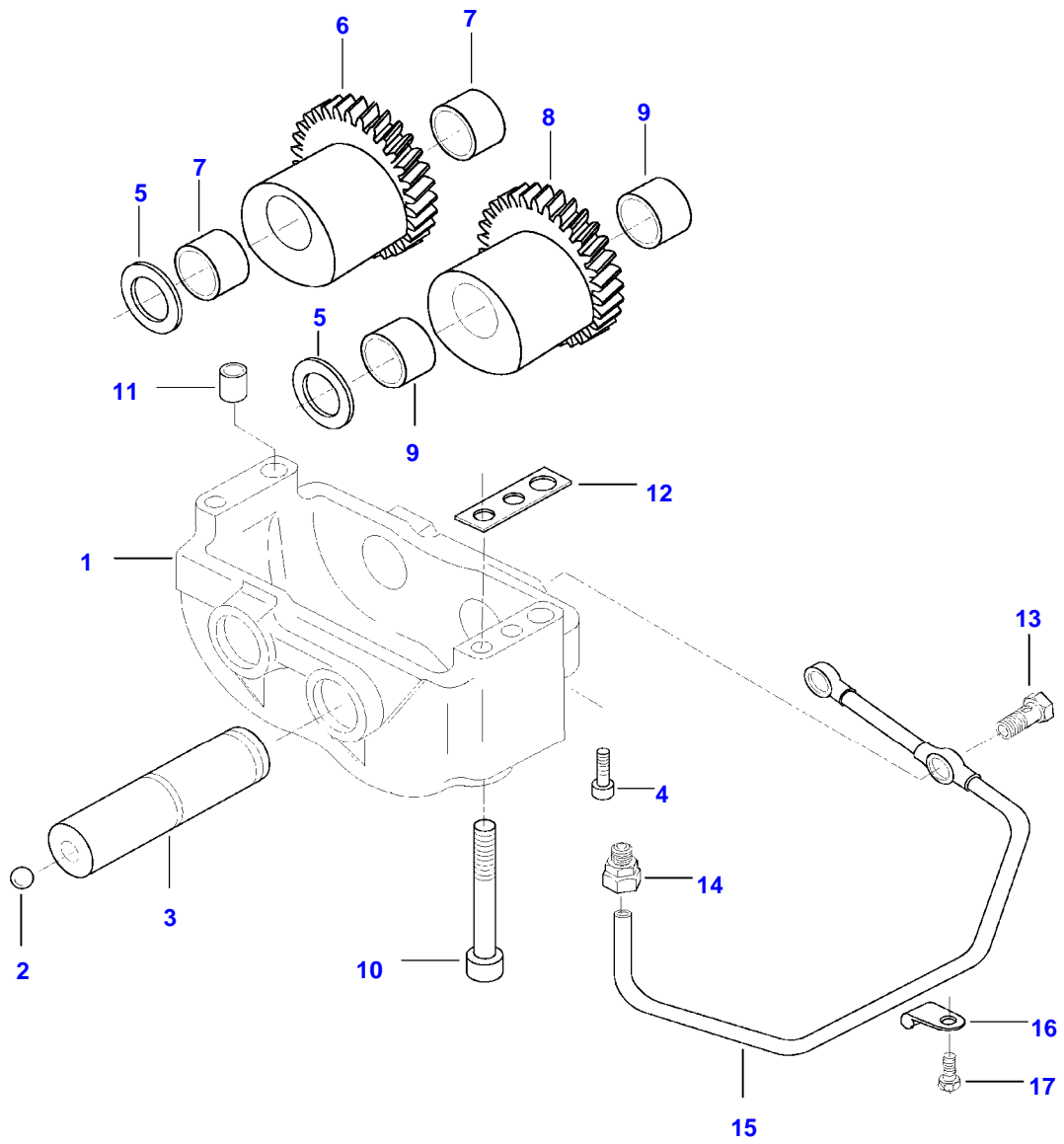

Item	Part Number	Qty	Description Comments
	V836766123	1	COUNTERWEIGHT
1	NS	1	NON-SERVICEABLE PART
			.
2	V616810103	2	FRAME BALL
			.
3	V836146879	2	SHAFT
			.
4	V581804202	2	HEX SOCKET SCREW
			.
5	V836146880	4	M6 X 20 THRUST WASHER
			.
6	V836766121	1	COUNTERWEIGHT
			.
7	V836146876	2	BEARING BUSH
			..
8	V836766122	1	COUNTERWEIGHT
			.
9	V836146876	2	BEARING BUSH
			..
10	V581805170	4	HEX SOCKET SCREW M10 X 100
11	V598359850	1	PIN
12	V836119920	X	SHIM
13	V640435008	2	BANJO BOLT
14	V641166008	1	ELBOW FITTING
15	V836747478	1	OIL PIPE
16	V602071608	1	RETAINER CLAMP
17	V528801062	1	HEX CAP SCREW M6 X 16

C100 TRACTOR (C SERIES)  
SPIMG-012-21-14

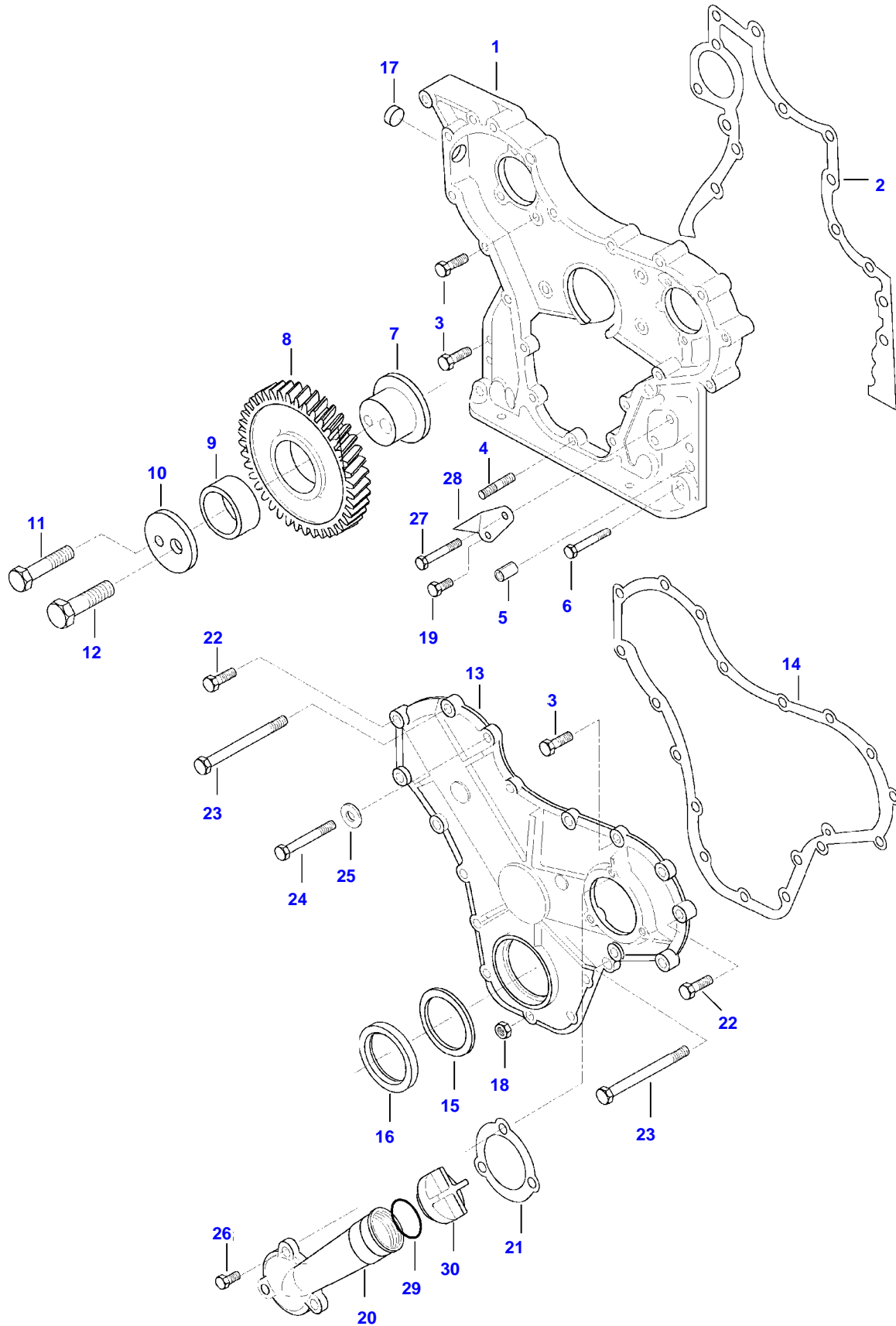

Item	Part Number	Qty	Description Comments
1	V836666400	1	TIMING GEAR CASE
2	V836647419	1	GASKET S2
3	V528801400	11	HEX CAP SCREW M8X25
4	V546801380	5	STUD BOLT M8X20
5	V598359850	4	PIN
6	V529801440	2	HEX CAP SCREW M8X45
7	V836129709	1	SHAFT
8	V836129863	1	IDLER GEAR
9	V836129844	1	BEARING BUSH
10	V836129845	1	FLANGE
11	V528801860	1	HEX CAP SCREW M10X55
12	V529902680	1	HEX CAP SCREW M14X65
13	V836647572	1	GEAR HOUSING FRONT COVER
14	V836129942	1	GASKET S2
15	V836129782	1	COVER
16	V614105880	1	OIL SEAL S2
17	V640016016	1	CUP PLUG
18	V504800800	5	NUT M8
19	V528801362	1	HEX CAP SCREW M8X16
20	V835338325	1	ENGINE OIL FILL PIPE
21	V836129946	1	GASKET S2
22	V528801420	3	HEX CAP SCREW M8X35
23	V529801500	2	HEX CAP SCREW M8X75
24	V529801470	3	HEX CAP SCREW M8X60
25	V836120989	1	WASHER
26	V528801380	3	HEX CAP SCREW M8X20
27	V529801450	1	HEX CAP SCREW M8X50
28	V836747675	1	TIMING MARK INDICATOR
29	V614603540	1	O-RING
30	V836017927	1	CAP



C100 TRACTOR (C SERIES)  
SPIMG-012-21-16

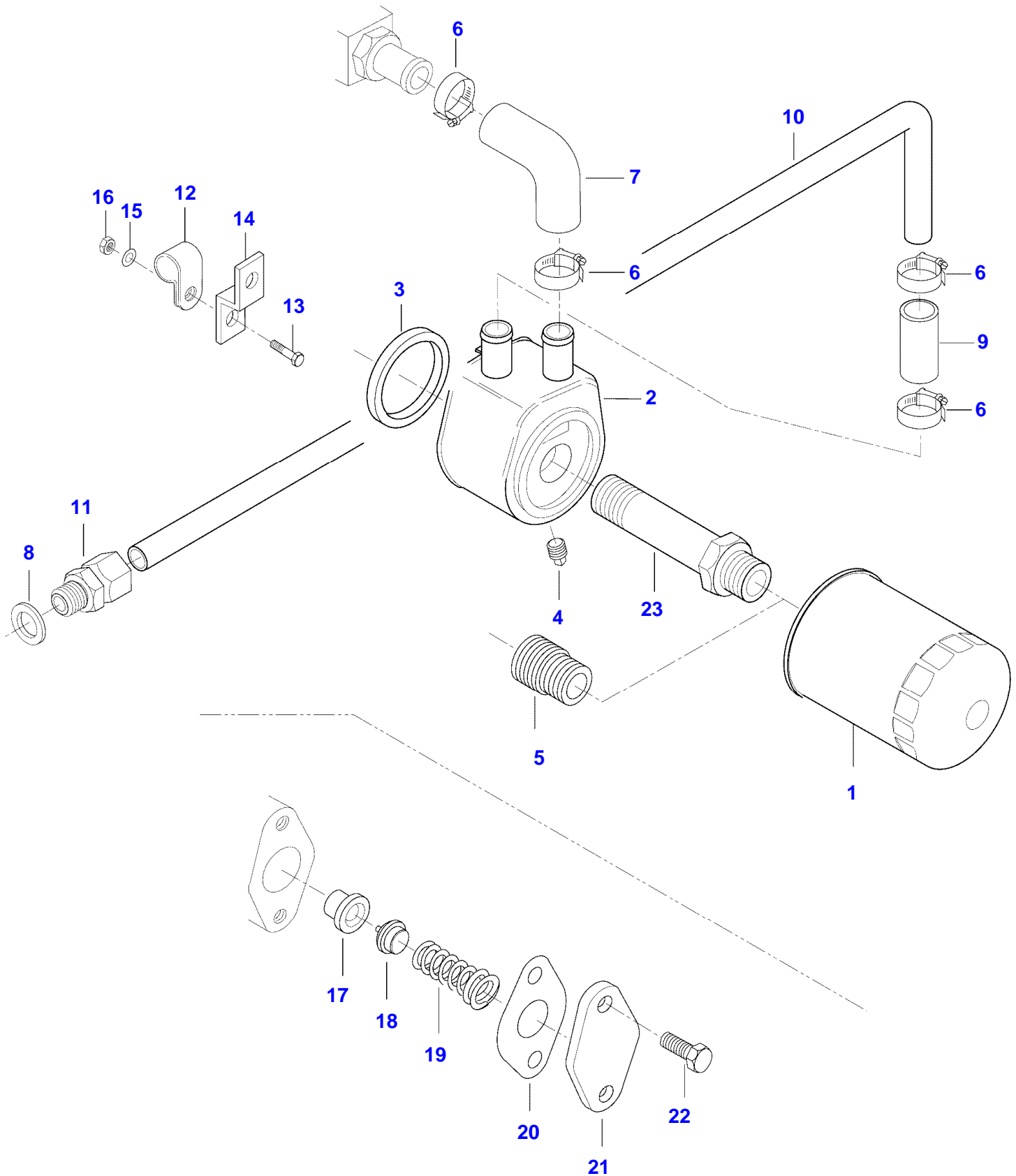

Item	Part Number	Qty	Description Comments
1	V836662580	1	ENGINE OIL FILTER
2	V836859699	1	OIL COOLER
3	V836862235	1	SEAL
4	V836131366	1	PLUG
5	V836647404	1	UNION
6	V602079516	4	HOSE CLIP
7	V836859899	1	RUBBER ELBOW
8	V615881822	1	SEALING WASHER S2
9	V836129978	1	RUBBER HOSE
10	V836747848	1	PIPE
11	V641086015	1	STRAIGHT FITTING
12	V602074615	1	RETAINER CLAMP
13	V528801102	1	HEX CAP SCREW M6 X 25
14	V836747849	1	SUPPORT
15	V500050642	2	WASHER
16	V504600602	1	NUT M6
17	V836662129	1	OIL PRESSURE CONTROL VALVE
17	V836659521	1	VALVE SEAT
18	V836659522	1	VALVE CONE
19	V836659523	1	SPRING
20	V836322190	1	GASKET S2
21	V836659524	1	COVER
22	V528801380	2	HEX CAP SCREW M8 X 20

C100 TRACTOR (C SERIES)  
SPIMG-012-21-18

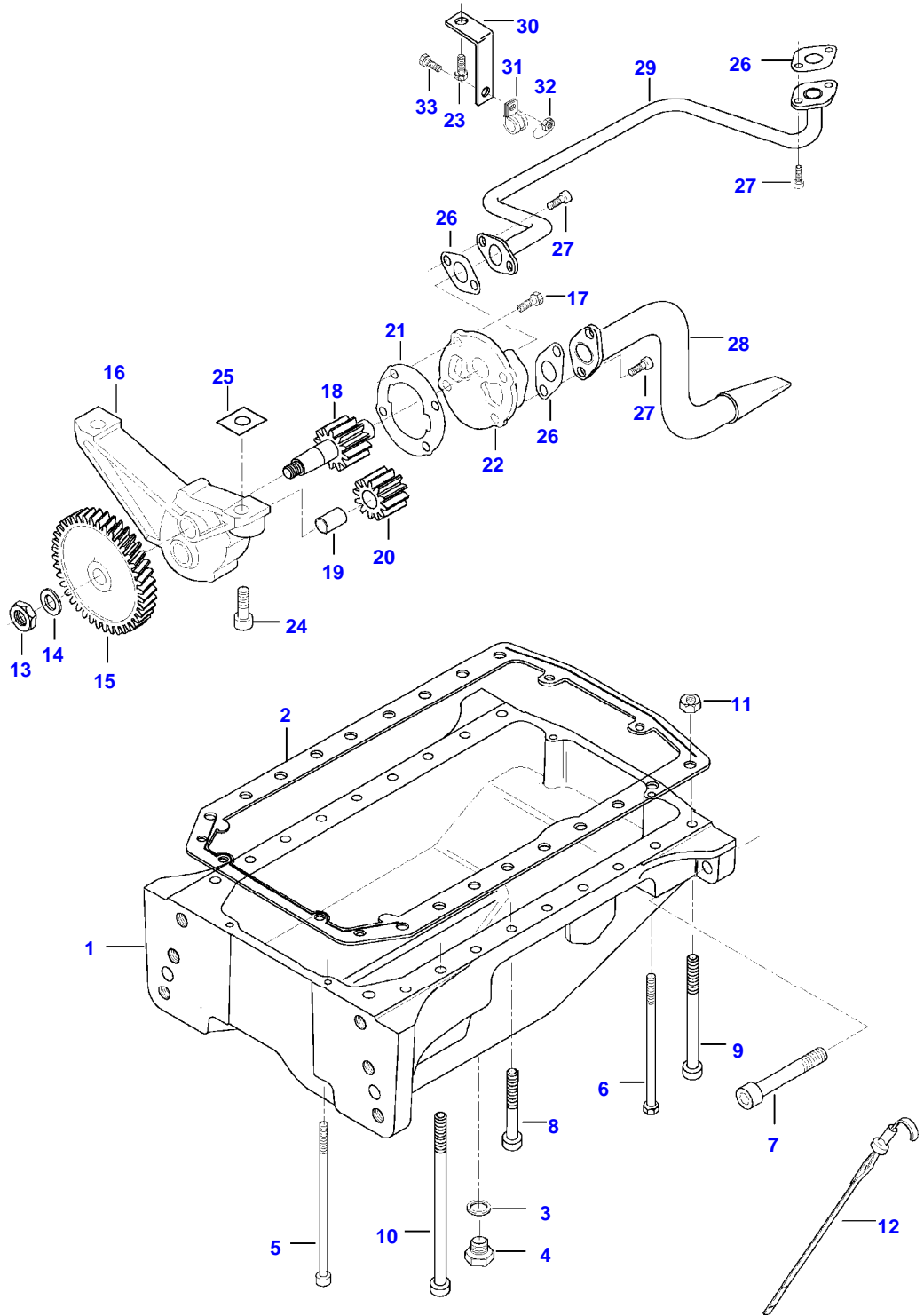

Item	Part Number	Qty	Description Comments
1	V836764262	1	OIL SUMP
2	V836129728	1	OIL SUMP GASKET S2
3	V615881827	1	SEALING WASHER S2
4	V836655493	1	PLUG
5	V581704830	2	HEX SOCKET SCREW M8 X 160
6	V529801595	2	HEX CAP SCREW M8 X 140
7	V581706290	4	HEX SOCKET SCREW M16 X 60
8	V581705510	8	HEX SOCKET SCREW M12 X 70
9	V581705580	6	HEX SOCKET SCREW M12 X 110
10	V581705640	4	HEX SOCKET SCREW M12 X 170
11	V504801202	16	NUT M12
12	V836014330	1	DIPSTICK
13	V836652603	1	LUBRICATING OIL PUMP
13	V504861000	1	NUT M10
14	V836122910	1	WASHER
15	V836338667	1	GEAR
16	V836120195	1	HOUSING
17	V528801380	4	HEX CAP SCREW M8 X 20
18	V836652600	1	OIL PUMP SHAFT
19	V836120191	1	OIL PUMP SHAFT
20	V836120193	1	GEAR
21	V836119796	1	GASKET S2
22	V836119794	1	COVER
23	V528801760	1	HEX CAP SCREW M10 X 16
24	V581805050	2	HEX SOCKET SCREW M10 X 40
25	V836007871	X	SHIM
26	V836008449	3	GASKET S2
27	V581804600	6	HEX SOCKET SCREW M8 X 20
28	V836664281	1	OIL PUMP SUCTION PIPE
29	V836746457	1	OIL PIPE
30	V836746572	1	SUPPORT
31	V602074618	1	RETAINER CLAMP
32	V504800800	1	NUT M8
33	V528801380	1	HEX CAP SCREW M8 X 20

C100 TRACTOR (C SERIES)  
SPIMG-012-21-20

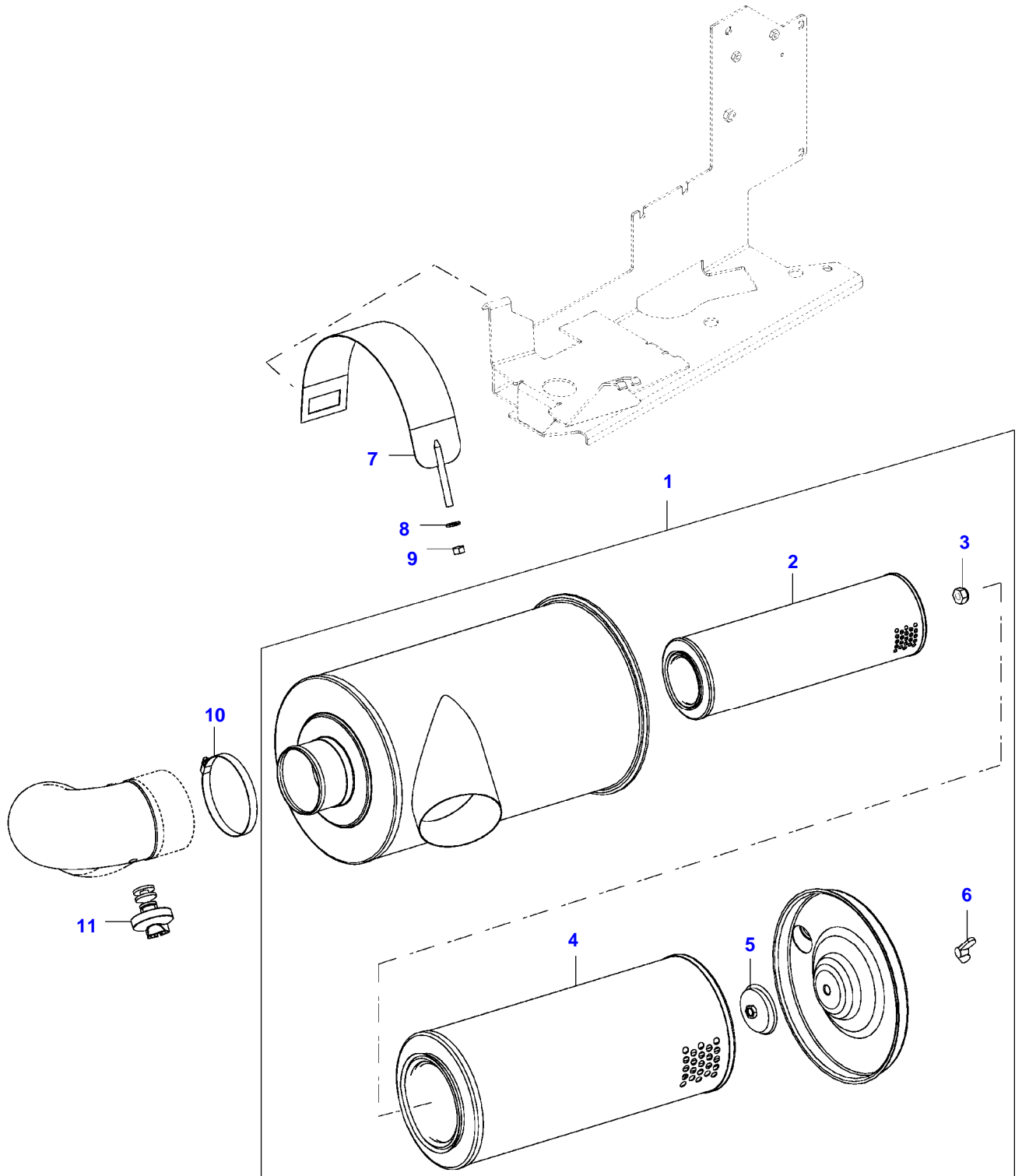

Item	Part Number	Qty	Description Comments	Technical Specification
1	V35188910	1	AIR FILTER ASSEMBLY	D=225
2	V836462569	1	SECONDARY AIR FILTER ELEMENT	
4	V836462568	1	PRIMARY AIR FILTER ELEMENT	
3	VJB8905	1	LOCKNUT	M10 SFS_EN_ISO_10511
5	V35315600	1	NUT	
6	VJC1610	1	BLADE NUT	M10 DIN315 G5 ZNE
7	V35296300	1	HOLDER	
8	V686930	1	WASHER	
9	VJB8904	1	NUT	M8
10	VGP3933	1	HOSE CLIP	D=95 SMS2298
11	V34654000	1	SENSOR	65 BAR

Thank you so much for reading.  
Please click the “Buy Now!”  
button below to download the  
complete manual.



After you pay.

You can download the most  
perfect and complete manual in  
the world immediately.

Our support email:

[ebooklibonline@outlook.com](mailto:ebooklibonline@outlook.com)