

## FENDT1000 Vario

### FENDT 1038 Vario S4

527 .. 1001-

### FENDT 1042 Vario S4

528 .. 1001-

### FENDT 1046 Vario S4

529 .. 1001-

### FENDT 1050 Vario S4

530 .. 1001-



# TABLE OF CONTENT

Entire vehicle system.....	1
Engine, fuel and exhaust system.....	2
Front axle.....	3
Steering system.....	4
Drive train.....	5
Compressed-air system.....	6
Hydraulic system.....	7
Electrical system.....	8
Cab.....	9
Air-conditioning system and heating.....	10
Chassis and body.....	11
Front power lift.....	12
Rear power lift.....	13
Service.....	14
Index.....	15

# 1 00-000 Entire vehicle system

<b>1.1</b>	<b>Safety instructions</b>	<b>1-5</b>
1.1.1	Safety briefing and measures	1-5
1.1.2	Importance of and position of the safety decals	1-7
<b>1.2</b>	<b>General information</b>	<b>1-18</b>
1.2.1	Assignment table FENDT T types to the EU Type Approval Number	1-18
1.2.2	Meaning of the vehicle identification number	1-19
1.2.3	Notes on documentation	1-19
1.2.4	Note on hydraulics	1-20
1.2.5	Support points for jack and support stands	1-21
1.2.6	Location of the identification plates	1-23
1.2.7	Standard and additional equipment	1-25
1.2.8	Identification of electrical cables	1-31
<b>1.3</b>	<b>Tightening requirements</b>	<b>1-35</b>
1.3.1	Spanner sizes for globally standard parts	1-35
1.3.2	Tightening torque for screws with a galvanized surface	1-35
1.3.3	Tightening torque for screws and bolts with VDA coating	1-37
1.3.4	Tightening requirements for threaded plugs	1-37
1.3.5	Tightening requirements of banjo bolts	1-38
1.3.6	Tightening torques for hose clamps	1-39
<b>1.4</b>	<b>Fuels and lubricants</b>	<b>1-41</b>
1.4.1	Biodiesel	1-41
1.4.2	Biodegradable hydraulic oil	1-41
<b>1.5</b>	<b>Technical specification</b>	<b>1-43</b>
1.5.1	General	1-44
1.5.2	Diesel engine	1-48
1.5.3	Front axle	1-54
1.5.4	Steering	1-56
1.5.5	Gearbox	1-57
1.5.6	Compressed air system	1-63
1.5.7	Hydraulic equipment	1-65
1.5.8	Electrical system	1-68
1.5.9	Cab	1-69
1.5.10	Air-conditioning system	1-70
1.5.11	Front power lift	1-71
1.5.12	Rear power lift	1-72
<b>1.6</b>	<b>Component position</b>	<b>1-73</b>
1.6.1	Electrical/electronic components - A	1-73
1.6.2	Electrical/electronic components - B	1-81
1.6.3	Electrical/electronic components - E	1-95
1.6.4	Electrical/electronic components - F	1-112
1.6.5	Electrical/electronic components - G	1-112
1.6.6	Electrical/electronic components - H	1-113
1.6.7	Electrical/electronic components - K	1-114
1.6.8	Electrical/electronic components - M	1-117
1.6.9	Electrical/electronic components - N	1-122
1.6.10	Electrical/electronic components - R	1-123
1.6.11	Electrical/electronic components - S	1-124
1.6.12	Electrical/electronic components - U	1-132
1.6.13	Electrical/electronic components - X	1-132
1.6.14	Electrical/electronic components - Y	1-197

1.6.15	Position of sockets . . . . .	1-208
1.6.16	Transmission components . . . . .	1-214
1.6.17	Hydraulic components . . . . .	1-226
1.6.18	Compressed air system components . . . . .	1-252
1.6.19	Components of the tire pressure monitoring system . . . . .	1-263
<b>1.7</b>	<b>Position of measuring points . . . . .</b>	<b>1-275</b>
1.7.1	Measuring points on transmission and comfort hydraulics . . . . .	1-275
1.7.2	Hydraulic measuring points . . . . .	1-279
1.7.3	Measuring points compressed air system . . . . .	1-281
<b>1.8</b>	<b>Settings and calibration . . . . .</b>	<b>1-284</b>
1.8.1	General information on calibration . . . . .	1-284
1.8.2	Calibration code 1001 - crossgate lever . . . . .	1-288
1.8.3	Calibration code 1003 ... 1006 - Linear module . . . . .	1-293
1.8.4	Calibration code 2401 - steering angle sensor . . . . .	1-296
1.8.5	Calibration code 2403 - Steering valve VarioGuide . . . . .	1-303
1.8.6	Calibration of transmission . . . . .	1-306
1.8.6.1	Calibration code 4001 - clutch pedal . . . . .	1-306
1.8.6.2	Calibration code 4002 - hand throttle . . . . .	1-308
1.8.6.3	Calibration code 4005 - accelerator / driving pedal . . . . .	1-310
1.8.6.4	Calibration code 4007 - transmission ratio characteristic . . . . .	1-312
1.8.6.5	Calibration code 4009 - turbo-clutch function . . . . .	1-318
1.8.6.6	Calibration code 4010 - Driving pedal resolution . . . . .	1-322
1.8.7	Calibration code 6034 - rear PTO clutch . . . . .	1-324
1.8.8	Calibration code 7666 - front axle suspension . . . . .	1-326
1.8.9	Calibration code 8001 / 8002 - Rear EPC . . . . .	1-328
1.8.10	Calibration code 9001 / 9002 front EPC . . . . .	1-334
1.8.11	Calibrating the heater valve (no code) . . . . .	1-339
1.8.12	Calibrating speed display . . . . .	1-340
1.8.13	Maintenance — change windscreen wiper (300°) (no code) . . . . .	1-342
1.8.14	Calibration of the gyro compass . . . . .	1-344
<b>1.9</b>	<b>Calibrations fault code . . . . .</b>	<b>1-345</b>
1.9.1	Calibration fault code 1001 . . . . .	1-345
1.9.2	Calibration fault code 1003 . . . . .	1-345
1.9.3	Calibration fault code 1004 . . . . .	1-345
1.9.4	Calibration fault code 1005 . . . . .	1-346
1.9.5	Calibration fault code 1006 . . . . .	1-346
1.9.6	Calibration fault code 2401 . . . . .	1-346
1.9.7	Calibration fault code 2403 . . . . .	1-347
1.9.8	Calibration fault code 4001 . . . . .	1-347
1.9.9	Calibration fault code 4002 . . . . .	1-348
1.9.10	Calibration fault code 4005 . . . . .	1-348
1.9.11	Calibration fault code 4007 . . . . .	1-348
1.9.12	Calibration fault code 4009 . . . . .	1-350
1.9.13	Calibration fault code 4010 . . . . .	1-351
1.9.14	Calibration fault code 7666 . . . . .	1-351
1.9.15	Calibration fault code 8001 . . . . .	1-352
1.9.16	Calibration fault code 9001 . . . . .	1-352
1.9.17	Calibration fault code tyre circumference . . . . .	1-352
1.9.18	Heater valve calibration fault code . . . . .	1-353
<b>1.10</b>	<b>Fault code tables . . . . .</b>	<b>1-354</b>
1.10.1	Note on the fault code table . . . . .	1-354
1.10.2	Confirm, call up and delete fault code . . . . .	1-354
1.10.3	Fault code 00.0.00 . . . . .	1-356
1.10.4	Fault code 01.0.00 . . . . .	1-359
1.10.5	Fault code 02.1.00 . . . . .	1-365
1.10.6	Fault code 03.1.00 . . . . .	1-367
1.10.7	Fault code 04.1.00 . . . . .	1-369

1.10.8	Fault code 05.1.00	1-384
1.10.9	Fault code 06.1.00	1-390
1.10.10	Fault code 08.1.00	1-395
1.10.11	Fault code 09.1.00	1-401
1.10.12	Fault code 0A.1.00	1-406
1.10.13	Fault code 0B.1.00	1-426
1.10.14	Fault code 0D.1.00	1-429
1.10.15	Fault code 0E.1.00	1-431
1.10.16	Fault code 0F.1.00	1-436
1.10.17	Fault code 10.1.00	1-441
1.10.18	Fault code 12.1.00	1-443
1.10.19	Fault code 15.1.00	1-451
1.10.20	Fault code 17.1.00	1-453
1.10.21	Fault code 18.1.00	1-454
1.10.22	Fault code 1A.1.00	1-458
1.10.23	Fault code 1D.1.00	1-464
1.10.24	Fault code 1F.1.00	1-476
1.10.25	Fault code 20.1.00	1-477



## 1.1 Safety instructions

### 1.1.1 Safety briefing and measures

#### Important notes on work safety

The statutory accident prevention regulations (available from professional associations or specialist shops) must be observed. These depend on the operating site, operating mode and fuels and lubricants used. Additional protective measures dependent on the respective procedures are specified in the corresponding repair guidelines and highlighted.

#### Safety instructions

This handbook uses the following safety tips:

**DANGER:**

**This symbol, together with the word DANGER, means there is an immediate risk of danger that must be avoided. Otherwise there is a risk of DEATH OR VERY SERIOUS INJURIES.**

**WARNING:**

**This symbol, together with the word WARNING, means there is a potential danger that must be avoided. Otherwise there is a risk of DEATH OR SERIOUS INJURIES.**

**CAUTION:**

**This symbol, together with the word CAUTION, means there is a potential danger that must be avoided. Otherwise there is a risk of MINOR INJURIES.**

#### Please observe the following when carrying out maintenance or service work to the tractor:

Only the documentation associated with the vehicle (workshop manual and operator's manual) must be used to complete any pending work.

#### 1. General

- Only briefed personnel may operate the tractor or carry out maintenance work.
- Only use qualified specialists to carry out repairs or service work.
- Nobody may be in the cab while work is being carried out under the jacked-up tractor.
- Relieve pressure on the pressure lines for implements.
- All people should keep clear of a lifted, unsecured load (e.g. tilted cab etc.).
- Never open or remove any safety devices while the engine is running.
- Pressurized fluids (fuel or hydraulic oil) escaping under high pressure can penetrate the skin and cause severe injuries. If this should occur, seek medical advice immediately to avoid the risk of serious infection.
- Keep at a safe distance from hot areas.
- Pressure accumulator and connected pipes are highly pressurized. Only remove and repair in accordance with instructions provided in the workshop manual.
- To avoid eye injury, do not look directly at the surface of the activated radar sensor.
- Dispose of oil, fuel and filters properly!
- Specialist knowledge and special fitting tools are required to fit tires.
- Run the tractor for a short time, then retighten all wheel nuts and bolts and check them regularly. For correct torque values refer to TECHNICAL DATA.
- Before working on the electrical system, always remove the earth strap from the battery. Observe the following when carrying out electric welding. Before carrying out welding work on tractor or mounted implements, ensure that both battery terminals are disconnected. Attach the welding appliance's earth terminal as close to the welding spot as possible.
- Caution is required when dealing with brake fluid and battery acid as these are toxic and corrosive!
- Only use genuine FENDT spare parts.

#### 2. Working on the front-axle suspension



**WARNING:** The front axle suspension pressure lines between the central control block and the suspension cylinder and the pipe of the cased pressure accumulator are under high pressure even when the engine is switched off and the suspension is lowered/locked.

**Risk of injury and death! Material damage is possible.**

**Prior to each repair and after releasing or opening hydraulic lines in this area, the pressure must be released manually!**

**NOTE:** The "Lock suspension/lower suspension" command has no effect!

**To release pressure:**

- Screw in the thumb screw on the **MVFS** [Y064] - Lower suspension solenoid valve ;  
the chassis may be lowered
- Screw in the thumb screw on the **MVFH** [Y065] - Raise suspension solenoid valve ;  
the rebound accumulator will be relieved

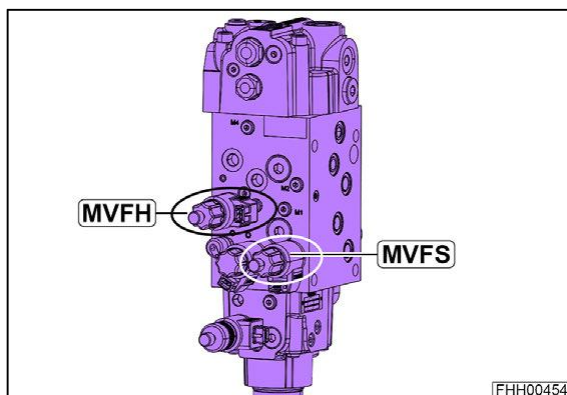

Fig. 1

**Check:**

As the oil temperature rises, the emptying accumulator will make a flowing sound. This is harder to hear at cold temperatures, however.

**3. Working on the brake system**



**DANGER:** The brake system lines remain under pressure even when the engine has been switched off!

**Compressed air escapes at high pressure!**

**Before each repair to the brake system or when removing the cab, the pressure must be relieved manually.**

**To release pressure:**

1. Engine must be off
2. Secure the tractor to prevent it from rolling away.
3. Actuate the foot brake at least 10 times

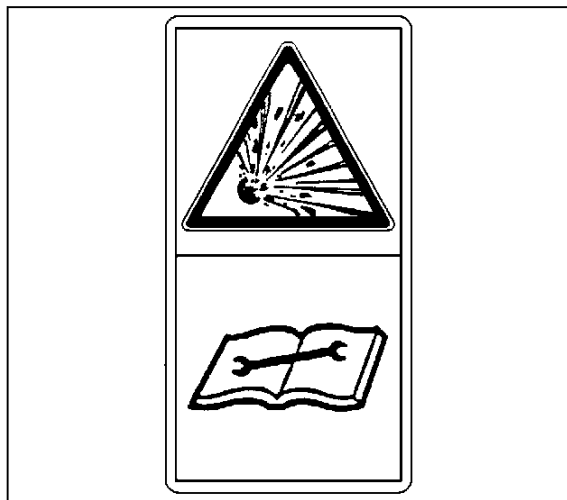

Fig. 2

**General notes:**

- Always check the brakes before driving.
- Adjustments and repairs to the brake system must be carried out in specialist workshops or by approved brake repair technicians.
- It must not be possible to brake individual wheels when driving (lock pedals)!

**4. Working on the engine**

- After switching the engine off, wait 30 seconds before carrying out any work on the fuel system.



- Only start the engine once all safety guards have been attached and nobody is standing in the danger area.
- Never let the engine run in enclosed spaces with no exhaust gas suction system.
- Cleaning, maintenance and repair work may only be carried out once the engine is switched off and secured to prevent it starting.
- Injection pipes and high-pressure lines must not be deformed.
- Any damaged injection pipe or high-pressure line must be replaced.
- Do not loosen any injection pipes for high-pressure fuel lines while the engine is running.
- Before carrying out checks to the running engine, always perform a visual check of all high-pressure components. Suitable protective clothing (e.g. protective goggles) should be worn while doing this. Leaks indicate potential sources of danger for workshop personnel.
- In the event of leaks to the high-pressure fuel system, always remain out of range of any possible fuel spray to avoid serious injury.
- Even when no leaks to the high-pressure fuel system can be detected, workshop personnel should avoid the immediate danger area and wear suitable protective clothing (such as protective goggles) when carrying out checks to the running engine and during the first test run.
- Smoking is forbidden while carrying out work to the fuel system.
- Do not work in the proximity of sparks or naked flames.
- Never disconnect an injector while the engine is running.

#### **5. Working on the PTO**

- Always switch off the engine before fitting or removing the drive shaft. PTO in "0" position!
- When working on the PTO, allow no-one in the vicinity of the rotating PTO or drive shaft.
- Make sure drive shaft and PTO are equipped with shield pipes and protective funnels.
- After deactivating the PTO, it is possible that parts on the mounted implement may continue to run. In this case, do not get too close to the implement. Work may only be carried out to the implement when nothing is moving!
- When the drive shaft is removed, cover the PTO shaft with its protective cap.
- Nobody should be in the cab when installing and removing the drive shaft.

Operation of controls for the tractor and mounted implements by people in the cab, especially children, may result in severe or fatal injury.

#### **Disposal**

The work described in the operator's manual and workshop manual includes replacing parts, fuel and lubricants. These renewed parts/fuel/lubricants must be stored, transported and disposed of in accordance with regulations. The repairing workshop bears responsibility for this. The disposal encompasses the recycling and final disposal of parts, fuel and lubricants with recycling having the higher priority. Details about disposal and monitoring are specified in regional, national and international laws and directives, the observation of which is the sole responsibility of the repairing workshops.

---

### **1.1.2 Importance of and position of the safety decals**

---

The position and importance of the safety decals on the vehicle are explained below:

**Position:** Left C-pillar, cab interior

743.810.090.050



**WARNING: Serious injury or death caused by inadequate compliance with the Operator's Manual**

**Inadequate compliance with the Operator's Manual can cause damage, injuries and in serious cases death.**

**Before operation, make sure that this Operator's Manual is available on the vehicle in legible form. The owner is responsible for providing adequate training to those personnel who are entrusted with the vehicle and for ensuring they are familiar with the instructions in the Operator's Manual and, where applicable, the service manual. The same applies to those persons who are both owner and operator.**

**Observe all safety notes and instructions, and execute all measures correctly and completely at all times.**



**Position:** Left B-pillar, cab interior

743.810.090.100



**WARNING: Serious injury or death caused by being ejected from the cab**

**When driving, an improperly closed door can open. Vehicle occupants not strapped in or not properly strapped in can be ejected from the vehicle and run over. This can cause serious injury and even death.**

**Make sure that, during travel, all vehicle passengers are properly strapped in at all times.**



**Position:** Left C-pillar, cab interior

743.810.090.060



**WARNING: Serious injury or death caused by being ejected from the cab**

**If the vehicle tips over, the door can open. Vehicle occupants not strapped in or not properly strapped in can be ejected from the vehicle. This can cause serious injury and even death.**

**Make sure that, during travel, all vehicle passengers are properly strapped in at all times.**



**Position:** Left C-pillar, cab interior

842.810.090.040



**WARNING: Unusual driving behavior in reverse drive mode can cause serious injury and even death**

**In reverse drive mode, steering the vehicle backwards can cause it to veer out at the rear and alter the driving behavior. This can cause serious injury and even death.**

**Reverse drive mode is prohibited on public roads. When not on public roads, travel in reverse drive mode with the utmost caution.**

**The Operator's Manual contains all important information.**



**Position:** Left B-pillar, cab interior

743.810.090.130



**WARNING: Serious injury or even death caused by critical driving situations due to the operator's seat lateral suspension being activated**

**When the lateral suspension is activated, critical driving situations can occur during road travel if the vehicle becomes difficult to operate. This can cause accidents involving serious injury and even death.**

**Deactivate the lateral suspension when travelling on public roads. When not on public roads, do not drive too fast when the lateral suspension is activated.**



**Position:** Left B-pillar, cab interior

743.810.090.150

**NOTE:** *Poisoning caused by inhaling substances that are hazardous to health*

*As the cab only provides protection against dust and not aerosols and vapors, additional protective equipment must be used.*

*Refer to Operator's Manual for safety instructions and the correct settings for the ventilation system.*



**Position:** Air filter housing, left side of vehicle, rear  
743.500.410.080



**DANGER: Scalding caused by hot coolant vapor**

After the vehicle has been operated, the cooling circuit contains pressurized, hot coolant. When the coolant reservoir or circuit is opened, the coolant escapes in the form of hot vapor and can cause scalding if allowed to come into direct contact with the skin.

Before opening the coolant reservoir or circuit, switch off the engine and allow sufficient time for the coolant to cool down.

The maintenance manual contains all important information.



**Position:** Lower right-hand side of engine cover, as well as on the right and left of the radiator  
743.500.410.060



**DANGER: Severe burns caused by contact with hot surfaces**

Components heated up by engine operation or external influences, e.g. engine parts, the exhaust system, hydraulic system etc. can cause severe burns on contact.

Maintain an adequate distance from hot components. If work has to be performed on these components, allow them to cool down first. Wear safety gloves if necessary.



**Position:** Battery box, right side of vehicle

743.500.410.030



**WARNING: Burns caused by explosive flames and chemical burns caused by battery electrolyte**

Direct contact with escaping battery electrolyte causes chemical burns to the eyes in particular. Escaping battery electrolyte can react with the ambient air to form an explosive mixture.

Avoid direct contact with battery electrolyte and always wear gloves and goggles when working with an open battery. During such work, do not use naked flames and avoid spark formation.

The Operator's Manual contains all important information.



**Position:** Fan left/right, front side

743.500.410.070



**WARNING: Danger of body parts being sheared or crushed**

Body parts being sheared or crushed by reaching into the running fan.

Switch the engine off and remove the ignition key before maintenance and repair work.



**Position:** Rear right-hand side at trumpet housing

743.810.090.090



**WARNING: Serious injury or death caused by running over persons when leaving the vehicle**

The vehicle can start rolling due to non-activation of the parking brake before leaving the vehicle, in which persons in the area of the vehicle can be caught and run over.

Apply the parking brake before leaving the vehicle and remove the ignition key.



**Position:** Right and left at radiator

743.500.410.050



**WARNING: Danger of body parts being crushed or pulled into the machine**

**Body parts sheared or crushed caused by reaching into the belt drive with the engine running.**

**Switch the engine off and remove the ignition key before maintenance and repair work.**



**Position:** Hydraulic pressure accumulator, right side of engine and left/right hydraulic pressure accumulator behind fuel tank and hydraulic pressure accumulator, left side of engine and hydraulic pressure accumulator between cab and lift shaft

X655.505.700.000



**WARNING: High-pressure injection-related injury caused by an escaping high-pressure jet of hydraulic oil**

**Components in the hydraulic system may be under high pressure even when the engine is switched off. If screw connections are opened improperly or hydraulic lines are removed incorrectly, a high-pressure jet of hydraulic fluid may escape. This can cause serious injuries, especially to the eyes. The high-pressure jet can also cause serious injury to the body and limbs and the hydraulic fluid can penetrate the skin and cause blood poisoning.**

**Ensure that work on the hydraulic system is only carried out by appropriately-trained maintenance personnel.**

**Never open screw connections on the hydraulic system or remove hydraulic lines when the engine is running or when the engine is starting up.**

**Release the pressure when the engine is switched off.**

**Wear personal protective equipment when working on the hydraulic system.**

**If you are hit by a high-pressure jet, immediately seek medical advice. The entry point may be hardly visible or not visible at all.**



**Position:** Left / right rear left mudguard, rear

743.810.090.030



**WARNING: Serious injuries or death during incorrect work on the PTO.**

When working on the PTO, a rotating PTO can cause crushing, shearing and impact injuries.

Before removing safety devices and performing other work on the PTO, remove the ignition key and make sure that the PTO cannot be reactivated until a safe state has been restored.

The maintenance manual contains all important information.

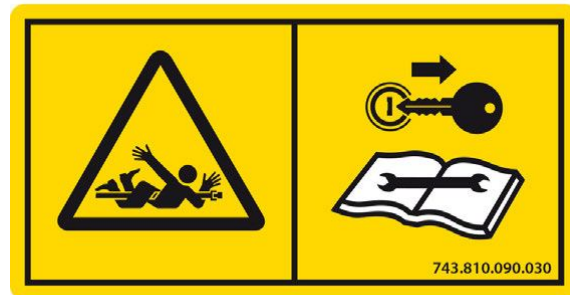

**Position:** Left/right rear mudguard, rear, as well as left side of engine, at front above front axle

737.500.410.030



**WARNING: Serious injury caused by incorrect power lift actuation**

When the rear power lift is actuated via the external pressure switch, any persons standing between the vehicle and the implement can be crushed as the implement is raised and positioned.

Make sure, when actuating the external pressure switch of the rear power lift, that nobody is standing between the vehicle and the implement.



**Position:** Left / right rear left mudguard, rear

743.810.090.040



**WARNING: Serious injury or death caused by the vehicle tipping over**

Exceeding the maximum permissible hitch load on the towing hitch can result in critical driving conditions through the front wheels being raised. In the worst case, the vehicle can tip over. This can cause serious injury and even death.

Always respect the maximum hitch load indicated on the sign plate of your vehicle.



**Position:** Cover of PTO stub

743.500.410.110



**DANGER:**  
 Danger of slipping and of serious injury. Do not use the PTO cover or rear linkage components as a step.



**Position:** Rear right mudguard, rear.

743.500.410.020



**DANGER:**  
 Danger due to parts being flung around if transmission shafts or implements are installed improperly. Observe the safety instructions in the Operator's Manual.

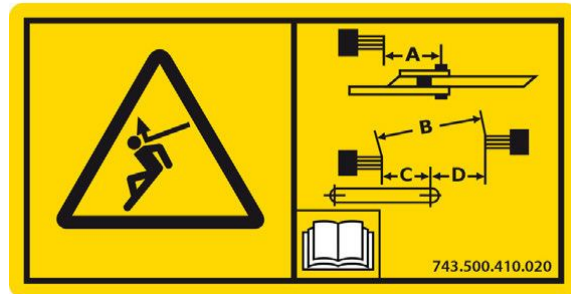

**Position:** Left/right side of front axle suspension cylinder

743.500.410.040



**DANGER:** Danger of body parts being sheared or crushed  
 When the vehicle is not moving, people in the front axle area could be injured when the vehicle body is raised or lowered

Switch the engine off and remove the ignition key before maintenance and repair work.



**Position:** Left/right bottom link lift rod, rear

835.870.030.060



**CAUTION:** Damage to the bottom link lift rod due to incorrect bottom link floatation

If the lift rod bolt is incorrectly set to floatation, the lift rod can become damaged.

Always set the lift rod bolt to the "top" position if a bottom link floatation is not required to operate the implement.

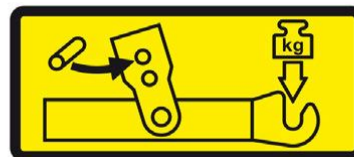

835.870.030.060



**Position:** Below the rear window and on the roof hatch, cab interior

530.811.090.040



**Position:** Right C-pillar, cab interior

743.810.090.110



**CAUTION: Damage caused by incorrect electric welding**

**Improper welding can damage electronic components and interfere with their operation.**

**Always disconnect the battery before welding. Position the welder ground clamp as close as possible to the welding point. Pay attention to temperature-sensitive parts.**

**The maintenance manual contains all important information.**



**Position:** Right C-pillar, cab interior

743.810.090.080



**CAUTION: Damage caused by incorrect towing**

**Towing in a gear position other than the towing position will damage the gearbox.**

**Before towing, ensure that the gearbox is in the towing position.**

**The Operator's Manual contains all important information.**



**Position:** Front of vehicle, on air-conditioning condenser

650,503,410,360

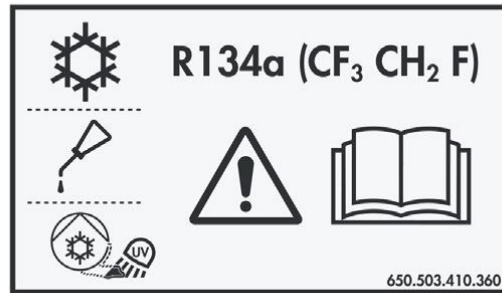

**Position:** Right mudguard, cab interior

743.810.090.070



**CAUTION: Damage caused by incorrect towing**

**To prevent transmission damage being caused by incorrect towing, always observe all important information in the towing instructions in the Operator's Manual.**

**Specifically, the vehicle should only be towed over a limited distance and at a speed of below 10 km/h.**

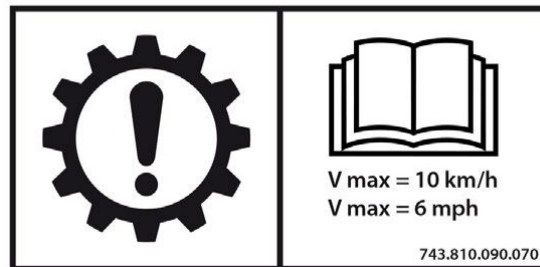

**Position:** Roof lining, centre right

743.810.090.120

**NOTE:**

*Recalibration of the tachograph after a tire change  
Always calibrate the tachograph after a rear tire change. Failure to do so can cause incorrect tachograph recordings.*

*The Operator's Manual contains all important information.*



**Position:** Battery box, right side of vehicle

530.500.410.020

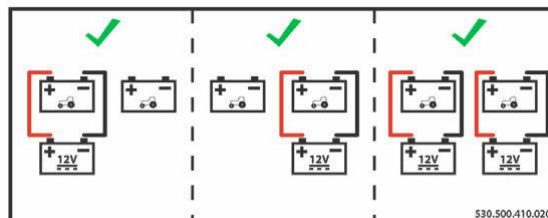

**Position:** Engine block

411.201.010.010



411.201.010.010

**Position:** Left side of engine, at the front above the front axle

954.500.410.020

Front lubrication points, see maintenance instructions

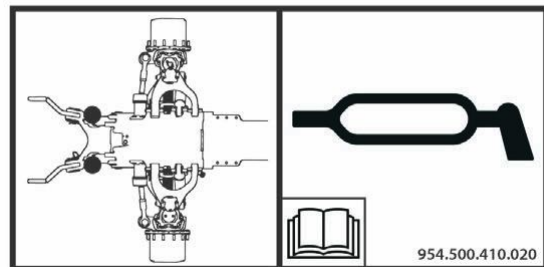

**Position:** On the right at the back on inside of mudguard

954,500,410,030

Rear lubrication points, see maintenance instructions

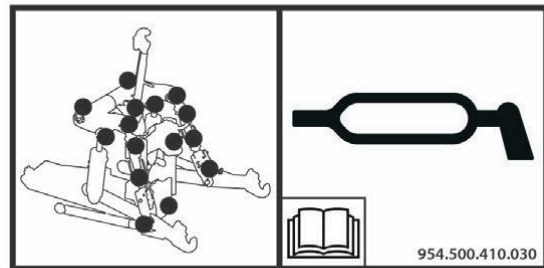

## 1.2 General information

### 1.2.1 Assignment table FENDT T types to the EU Type Approval Number

The EU type approval number consists of the lower case letter "e" followed by the code letter or number of the member state granting the EU type approval. The FENDT T-type designation classifies the relevant series and forms part of the 17-digit vehicle identification number.

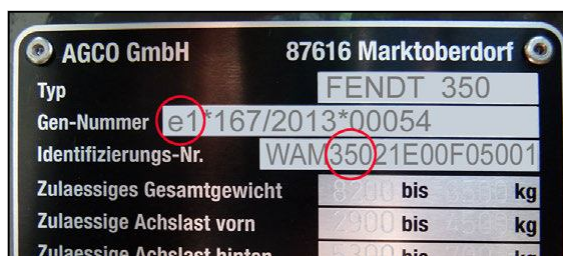

Fig. 3 Exemplary illustration

Series	FENDT 200 Vario V/F/P	FENDT 200 Vario	FENDT 300 Vario
<b>Type approval number</b>	<b>e1*167/2013*00053</b>		<b>e1*167/2013*00054</b>
<b>Chassis numbers</b>	T232	T300	T347
	T233	T301	T348
	T234	T302	T349
	T235	T303	T350
	T236	T304	
	T239		
	T240		
	T241		
	T242		
	T243		
	T251		
	T252		
	T253		

Series	FENDT 500 Vario	FENDT 700 Vario	FENDT 800 Vario
<b>Type approval number</b>	<b>e1*167/2013*00042</b>	<b>e1*167/2013*00049</b>	<b>e1*167/2013*00047</b>
<b>Chassis numbers</b>	T435	T738	T839
	T436	T739	T840
	T437	T740	T841
	T438	T741	T842
		T742	
		T743	

Series	FENDT 900 Vario	FENDT 1000 Vario
<b>Type approval number</b>	<b>e1*167/2013*00056</b>	<b>e1*167/2013*00055</b>
<b>Chassis numbers</b>	T950	T527
	T951	T528
	T952	T529
	T953	T530
	T954	

## 1.2.2 Meaning of the vehicle identification number

VIN	W	A	M	3	5	0	2	1	E	0	0	F	0	5	0	0	1
Pos.	1	2	3	4	5	6	7	8	9	10	11	12	13	14	15	16	17

Fig. 4

Digits		Meaning
1-3	WAM	Global manufacturer code, represents AGCO GmbH, Marktoberdorf
4-6	350	Series type identifier, in this case FENDT 313 Vario S4
7-8	21	Version ID, in this case a 4WD Profi/Profi Plus tractor
9	E	Checksum resulting from the programming and information from digits 1 to 8 and 10 to 17
10	0	Model or year of production: not currently in use
11	0	Manufacturer's works: not currently in use
12	F	Tractor brand (F = FENDT, C = Challenger)
13-17	05001	Serial number

## 1.2.3 Notes on documentation

To ensure that the information is structured in a user-friendly manner, the service documentation is divided into the operator's manual and the workshop manual.

The operator's manual includes a general description as well as instructions for all necessary maintenance work.

Knowledge of the owner's manual is essential to understand the workshop manual. This is particularly important for safety instructions. The workshop manual describes repairs to assemblies and components that will require more effort and suitably qualified specialists to carry out.

### Note

This workshop manual provides notes for trained technicians to maintain our tractors. Read and observe the information in this documentation. This will help you prevent accidents and safeguard the manufacturer's warranty.

The respective accident prevention rules as well as other generally recognized safety and occupational health rules must be observed.

The tractor is built solely for the purpose defined by the implement manufacturer. Any other type of use is considered unauthorized. The manufacturer bears no liability for any damage resulting from improper use. The user bears this risk alone. Intended use includes maintaining operating, service and maintenance conditions as specified by the manufacturer.

## 1. 00-000 Entire vehicle system

---

Operation, maintenance and repair of the tractor may only be carried out by people who are familiar with this equipment and aware of the associated dangers. Ensure that this documentation is available to and understood by everyone involved in operation, maintenance and repair. Not observing this documentation can lead to faults, damage and personal injury, for which the manufacturer assumes no liability. The prerequisite for the tractor being correctly serviced and maintained is the perfect condition and availability of all necessary equipment, standard tools and general workshop equipment as well as special tools. Special tools must only be used where absolutely necessary. The tools are displayed where they need to be used in each case.

The machine must be maintained according to its proper use. Always replace parts with genuine FENDT spare parts! When ordering parts, please provide the chassis number as per the most up-to-date spare parts documentation.

Only parts approved by the manufacturer for that specific purpose may be used for any alterations. The manufacturer will not accept liability for any damage resulting from unauthorized modifications to the tractor. Non-compliance invalidates the warranty!

Workshops should also refer to documentation on maintenance work and technical data. Once maintenance is complete, take a test drive to ensure the vehicle's correct operation and road safety.

We reserve the right to make design changes in light of technical developments.

### **Notes on repairs**

The assembly/disassembly instructions shown correspond to the design status at the time the workshop manual was drawn up.

Further technical development of the product and additions related to different versions may require alternative working processes that do not pose too many difficulties to trained and qualified specialists.

These assembly/disassembly instructions shall be invalidated upon issue of the next version of this document.

---

### **1.2.4 Note on hydraulics**

If work has been carried out on the hydraulic system on the vehicle, in particular the steering, the hydraulic system must be checked in line with the test report.

**1.2.5 Support points for jack and support stands**

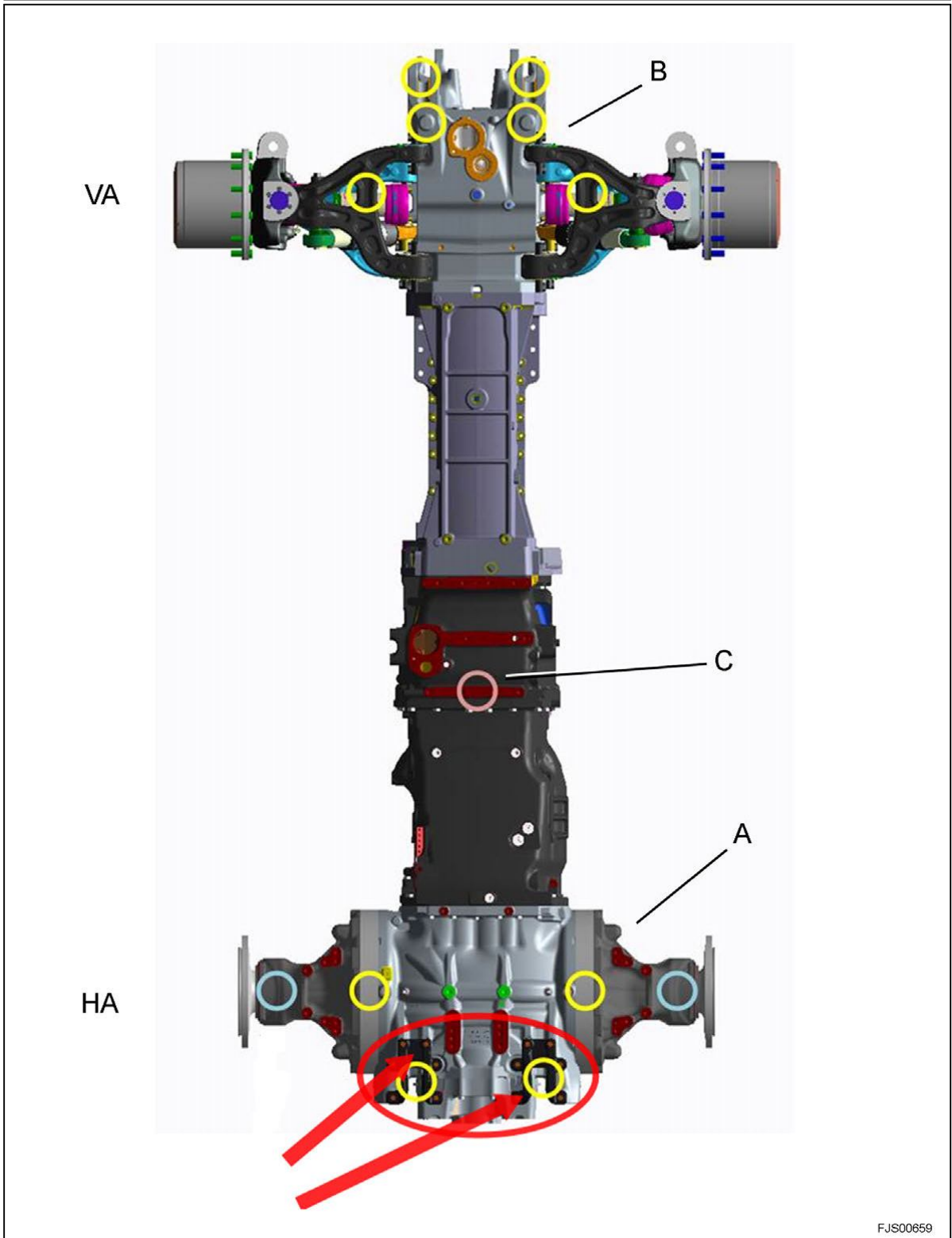

Fig. 5

(A) Supporting points on rear axle

(B) Supporting points on front axle

(C) Supporting point on coupler housing  
 (RA) Rear axle

(FA) Front axle

### Supporting points A on rear axle

Designation	Note
Ring gears	
Lower link stands	There are no lower link stands in the "tractor without rear power lift" version.  The open mounting surfaces (arrows) are <b>not</b> suitable for positioning the jack! (see also image below)
Trumpet housing	Used as a supporting point when rear wheels removed

### Supporting points B on front axle

Designation	Note
Front-axle (VA) lower link support	
Front axle housing	For round contact surfaces
Front-axle jib	

### Supporting point C on coupler housing

Designation	Note
Contact surface (C) on coupler housing	Used as a supporting point when rear axle is removed



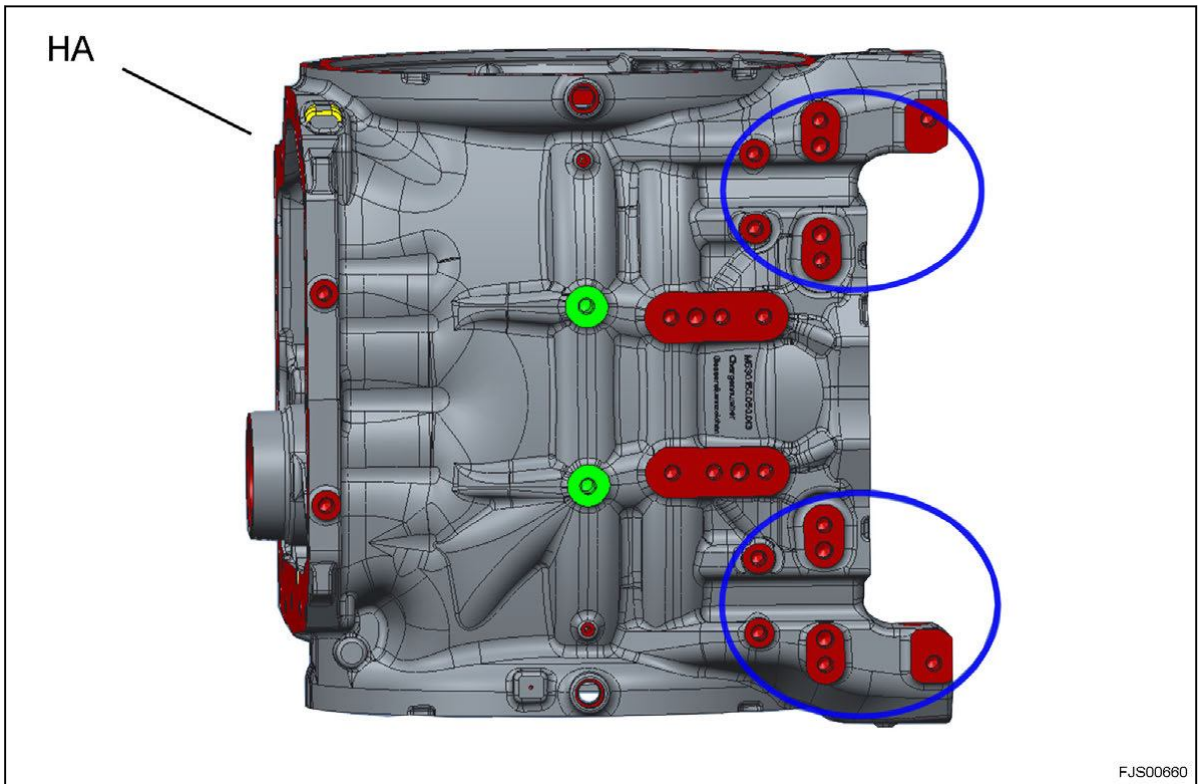

Fig. 6  
(RA) Rear axle

**NOTE:** There are no lower link stands in the “tractor without rear power lift” version.  
The open mounting surfaces (highlighted in the image) are **not** suitable for positioning the jack!

## 1.2.6 Location of the identification plates

### Stamped chassis number



On the right-hand side of the frame, at the front

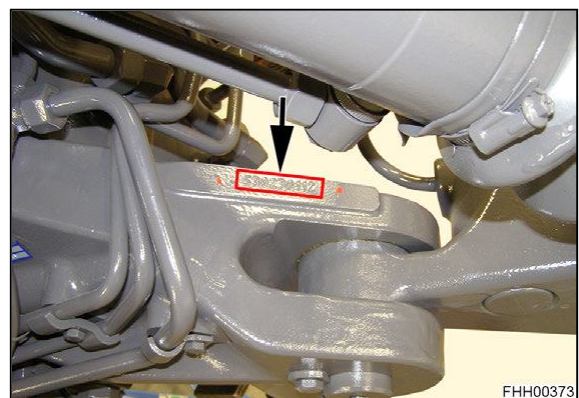

Fig. 7

**Front axle rating plate**



Right-hand side, on front axle

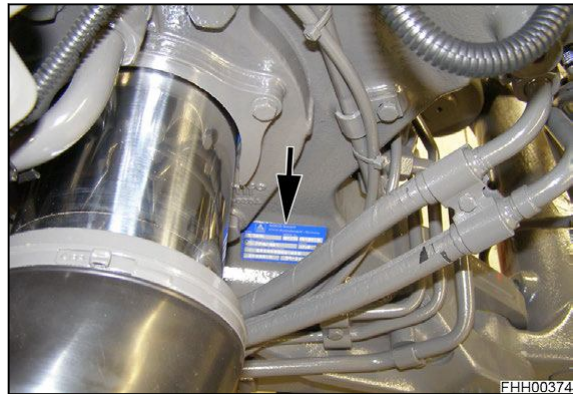

Fig. 8

**Diesel engine rating plate**



Right side of engine

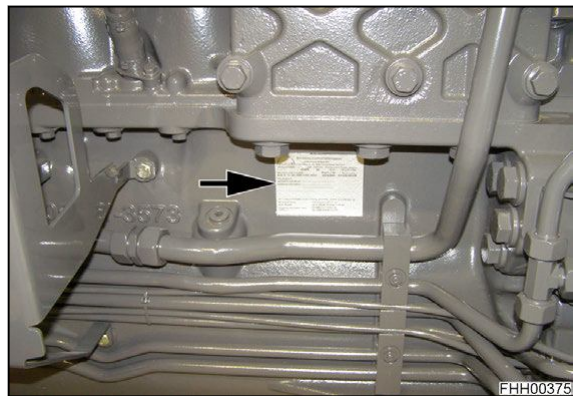

Fig. 9

**Diesel engine rating plate**



Left side of engine, behind alternator

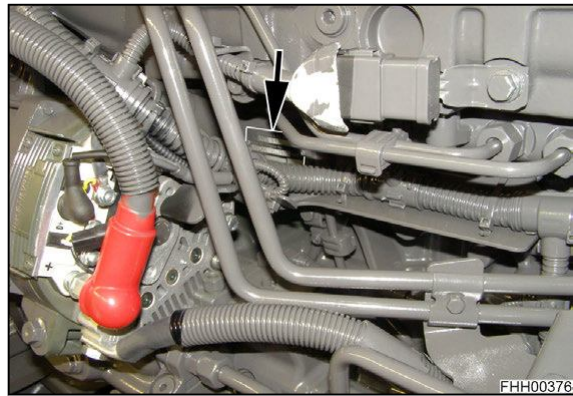

Fig. 10

**Transmission rating plate**



Right side, on transmission housing

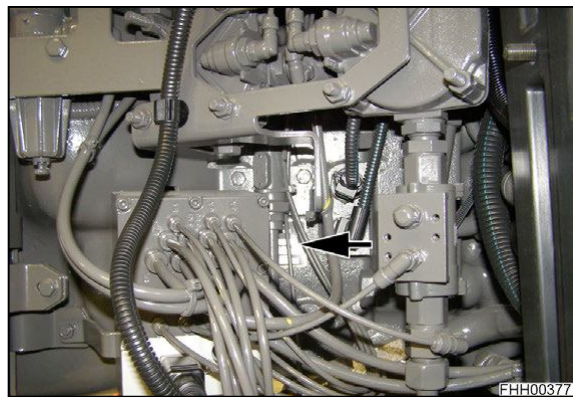

Fig. 11

### Infinitely variable gearbox - sign plate



On top of infinitely variable gearbox



Remove infinitely variable gearbox

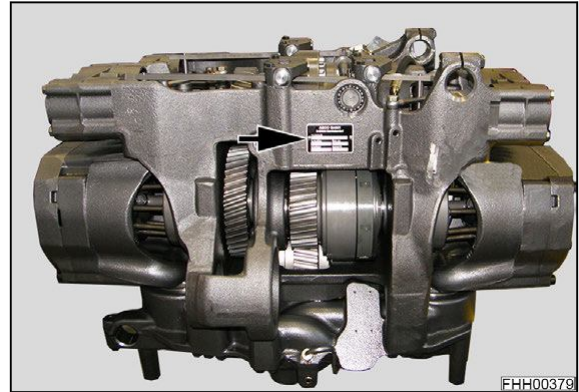

Fig. 12

### Cab rating plate



In the cab, on the left-hand B-pillar between the panel and the side plate

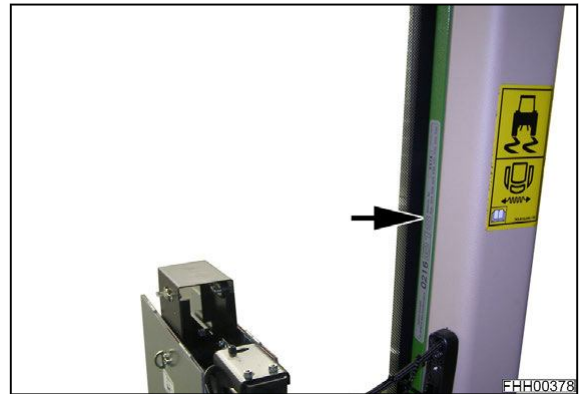

Fig. 13

### Trailer frame rating plate



On the right-hand side of the trailer frame

**NOTE:**

See also: *Operating Manual*

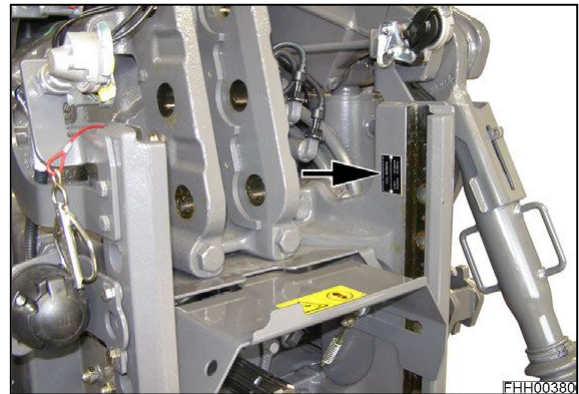

Fig. 14

## 1.2.7 Standard and additional equipment

Equipment	PowerPlus	PROFI	ProfiPlus
<b>Vario operation</b>			
Joystick with cruise control and speed memory, automatic functions	■	-	-
Multifunction joystick with cruise control, speed memory, automatic functions, hydraulics control	-	■	■
7" Varioterminal	■	■	-

Thank you so much for reading.  
Please click the “Buy Now!”  
button below to download the  
complete manual.



After you pay.

You can download the most  
perfect and complete manual in  
the world immediately.

Our support email:

[ebooklibonline@outlook.com](mailto:ebooklibonline@outlook.com)