

ERC/ERP16-20AAF (A814)

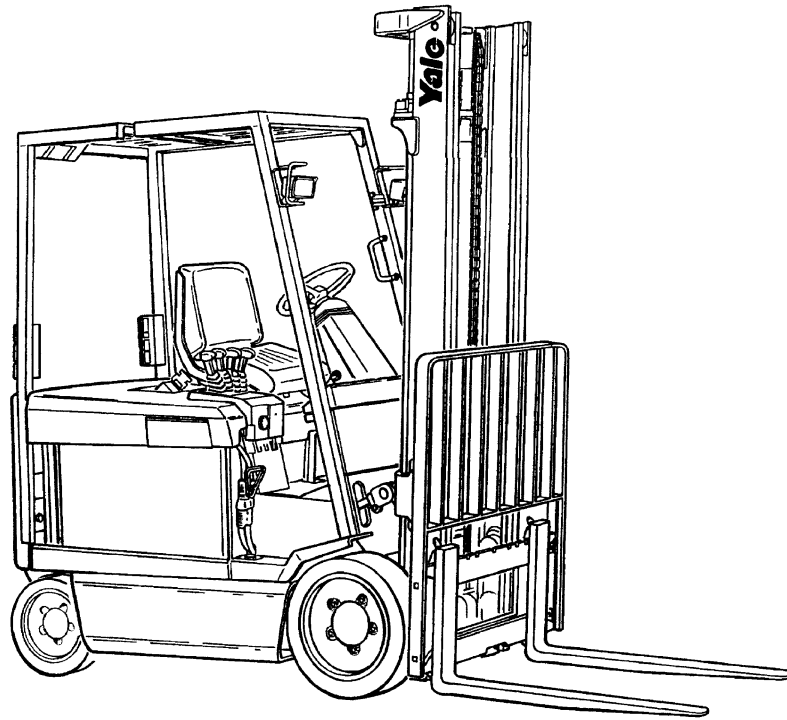

YP990107

1	GENERAL TRUCK	
2	ELECTRICAL SYSTEM	
3	DRIVE UNIT	
4	STEERING SYSTEM	
5	BRAKE SYSTEM	
6	HYDRAULIC SYSTEM	
7	MAST-TWO STAGE LIMITED FREE-LIFT	
8	MAST-THREE STAGE FULL FREE-LIFT	
9	MAST-TWO STAGE FULL FREE-LIFT	
10	FORKS, LOAD BACKREST, AND MAST INSTALLATION	
11	OPTIONS	
12	NUMERICAL INDEX	

ALPHABETICAL INDEX

DESCRIPTION	PAGE NO.
A	
ABBREVIATIONS QUICK REFERENCE SHEET	viii
ACCELERATOR	1.18
ALPHABETICAL INDEX.....	i
AUXILIARY TUBES	
TWO AND THREE STAGE FULL FREE-LIFT	
FOUR FUNCTION GROUP	11.14
B	
BACK-UP ALARM	11.26
BATTERY CONNECTOR	2.92
BRAKE AND BACK-UP LIGHTS	
12 VOLT	
⇒S/N A814A02166W.....	11.16
S/N A814A02167W⇒.....	11.18
BRAKE ASSEMBLY	
D/B 07/1997⇒	5.4
⇒D/B 07/1997	5.2
BRAKE PEDAL LINKAGE	5.6
C	
CARRIAGE	
THREE STAGE FULL FREE-LIFT	8.18
TWO STAGE FULL FREE-LIFT	9.20
TWO STAGE LIMITED FREE-LIFT.....	7.12
CONTACTOR	
1A/P	2.48
300 AMP	2.52
300 AMP 60V-DC	
S/N A814A-02167w⇒	2.60
FIELD WEAKENING	
⇒S/N A814A-02166W	2.54
PUMP.....	2.50
STEERING	
⇒S/N A814A-02166W	2.56
S/N A814A-02167W⇒	2.58
CONTACTOR PANEL	
REGENERATIVE BRAKING WITH OR WITHOUT BDI AND LIFT INTERRUPT	
⇒S/N A814A-02166W	2.32
SHEET 1 OF 2	
S/N A814A-02167W⇒	2.36
SHEET 2 OF 2	
S/N A814A-02167W⇒	2.38
WITH BDI AND LIFT INTERRUPT	
⇒S/N A814A-02166W	2.34
WITH BDI, LIFT INTERRUPT, AND FIELD WEAKENING	
SHEET 1 OF 2	

DESCRIPTION	PAGE NO.
C (continued)	
⇒S/N A814A-02166W	2.28
SHEET 2 OF 2	
⇒S/N A814A-02166W	2.30
CONTROL PANEL	
CONTACTOR HYDRAULIC	
S/N A814A-02167W⇒	2.22
TRANSISTOR HYDRAULIC	
S/N A814A-02167W⇒	2.26
CONTROL VALVE	
FOUR FUNCTION	6.22
THREE FUNCTION	6.18
CONTROL VALVE ATTACHING PARTS	
FOUR FUNCTION	6.14
THREE FUNCTION	6.10
TWO FUNCTION	6.6
COUNTERWEIGHT	1.24
COVERS	1.34
D	
DIFFERENTIAL	3.8
DIRECTION CONTACTOR	
⇒S/N A814A-02166W	2.46
DRIVE AXLE	3.2
DRIVE MOTOR MOUNT	
⇒S/N A814A-02831A	6.28
S/N A814A-02832A⇒	6.50
DRIVE TIRE AND WHEEL	
INTERMEDIATE PNEUMATIC-SHAPED SOLID TIRES	3.20
PNEUMATIC AND PNEUMATIC SHAPED SOLID TIRES.....	3.18
E	
ELECTRICAL SYSTEM	
CONTACTOR HYDRAULIC	
⇒S/N A814A-02166.....	2.4
S/N A814A-02167W⇒	2.8
TRANSISTOR HYDRAULIC	
⇒S/N A814A-02166W	2.12
S/N A814A-02167W⇒	2.16
F	
FOOT DIRECTIONAL CONTROL PEDAL	
S/N A814A02167W⇒	1.20
FORK	
2000 KG.....	10.8
STANDARD TAPER	
1600 KG	10.6
FRAME	1.36
FREE-LIFT	

DESCRIPTION	PAGE NO.
F (continued)	
THREE STAGE FULL FREE-LIFT	8.10
TWO STAGE FULL FREE-LIFT	9.8
FREE-LIFT CYLINDER	
THREE STAGE FULL FREE-LIFT	8.16
TWO STAGE FULL FREE-LIFT	9.18
FULL SUSPENSION SEAT	
D/B 12/2000⇒	1.9
G	
GEAR PUMP	
D/B 11/1997⇒	4.16
⇒D/B 11/1997	4.14
OPTIONAL.....	4.18
H	
HAND LEVER.....	6.2
HEADER HOSE	
FOUR FUNCTION	
THREE STAGE FULL FREE-LIFT	8.22
TWO STAGE FULL FREE-LIFT	9.24
TWO STAGE LIMITED FREE-LIFT	7.16
THREE FUNCTION	
THREE STAGE FULL FREE-LIFT	8.20
TWO STAGE FULL FREE-LIFT	9.22
TWO STAGE LIMITED FREE-LIFT	7.14
HOOD.....	1.30
HOW TO FIND THE DESIRED PART NUMBER.....	x
HOW TO USE THE ILLUSTRATED PARTS MANUAL	x
HYDRAULIC	
⇒S/N A814A-02831A.....	6.44
S/N A814A-02832A⇒.....	6.48
HYDRAULIC MOTOR	
PREMIUM TRUCK	
⇒D/B 04/2000.....	2.82
S/N A814A-02832A⇒.....	6.42
WITH BWI	
D/B 12/1999⇒.....	2.90
ECONOMY TRUCK	
⇒D/B 12/1999	2.88
WITHOUT BWI	
ECONOMY TRUCK	
⇒D/B 12/1999	2.84
D/B 12/1999⇔D/B 04/2000	2.86
HYDRAULIC PUMP	
12 CC	
HALDEX	
S/N A814A-01970V⇒.....	6.34
12 CC AND 19 CC	

DESCRIPTION	PAGE NO.
H (continued)	
⇒S/N A814A-01969V	6.30
12 CC STANDARD	
KAYABA	
S/N A814A-01970V⇒	6.32
19 CC	
PREMIUM	
S/N A814E-01970V⇒	6.38
19 CC WITH BWI AND THERMOSTAT	
S/N A814A-02832A⇒	6.40
BOSCH	
12 AND 19 CC.....	6.41
HYDRAULIC PUMP ASSEMBLY	
12 CC PREMIUM WITH BWI AND THERMOSTAT	
SPLINED SHAFT	
S/N A814A-02832A⇒	6.36
HYDRAULIC TANK.....	6.52
I	
IDENTIFICATION OF TRUCK SERIAL NUMBER.....	xi
INNER MAST	
THREE STAGE FULL FREE-LIFT	8.6
TWO STAGE FULL FREE-LIFT	9.4
TWO STAGE LIMITED FREE-LIFT.....	7.4
INSTRUMENT PANEL	
ECONOMY DASH DISPLAY	
⇒S/N A814A-02166W	2.64
PREMIUM DASH DISPLAY	
⇒S/N A814A-02166W	2.62
SCR	
⇒S/N A814A-02166W.....	2.66
S/N A814A-02167W⇒	2.68
INTEGRAL SIDE-SHIFT CARRIAGE	
TWO AND THREE STAGE FULL FREE-LIFT	11.8
TWO STAGE LIMITED FREE-LIFT.....	11.6
INTEGRAL SIDE-SHIFT CYLINDER	11.10
INTEGRAL SIDE-SHIFT HYDRAULIC HOSES	
TWO AND THREE STAGE FULL FREE-LIFT	11.13
TWO STAGE LIMITED FREE-LIFT.....	11.12
INTERMEDIATE MAST	
THREE STAGE FULL FREE-LIFT	8.4
L	
LABELS.....	1.23
LIFT	
TWO STAGE LIMITED FREE-LIFT.....	7.6
LIFT TRUCK.....	1.2
LOAD BACKREST EXTENSION.....	10.2

DESCRIPTION	PAGE NO.
M	
MAIN CYLINDER	
LEFT HAND	
THREE STAGE FULL FREE-LIFT	8.12
TWO STAGE FULL FREE-LIFT	
⇒S/N A559B-1677	9.10
S/N A559B-1678⇒	9.12
TWO STAGE LIMITED FREE-LIFT	7.8
RIGHT HAND	
THREE STAGE FULL FREE-LIFT	8.14
TWO STAGE FULL FREE-LIFT	
⇒S/N A559B-1677	9.14
S/N A559B-1678⇒	9.16
TWO STAGE LIMITED FREE-LIFT	7.10
MAIN LIFT	
THREE STAGE FULL FREE-LIFT	8.8
TWO STAGE FULL FREE-LIFT	9.6
MAST INSTALLATION	10.4
MASTER CYLINDER	5.12
N	
NON-SUSPENSION SEAT	
D/B 08/1998⇒	1.4
SEARS	
D/B 08/1998⇒	1.14
⇒D/B 08/1998	1.12
O	
OUTER MAST	
THREE STAGE FULL FREE-LIFT	8.2
TWO STAGE FULL FREE-LIFT	9.2
TWO STAGE LIMITED FREE-LIFT	7.2
OVERHEAD GUARD	
D/B 06/1996⇒	1.28
⇒D/B 06/1996	1.26
P	
PARK BRAKE	5.8
S	
SEAT ASSEMBLY	
SCHNEIDER	1.16
SEMI-SUSPENSION SEAT	1.6
SHIFT LEVER	2.70
SIDE-SHIFT CARRIAGE	11.2
SIDE-SHIFT CYLINDER	11.4
STEER TIRE AND WHEEL	4.38
STEERING CONTROL UNIT	
⇒S/N A814A-01757V	4.10
S/N A814A-01758V⇒	4.12

DESCRIPTION **PAGE NO.**

S (continued)

STEERING CYLINDER
 D/B 02/1999⇒ 4.22
 ⇒D/B 02/1999 4.20
 STEERING HYDRAULIC..... 4.24
 STEERING MOTOR
 WITH BWI
 ⇒D/B 09/1997 4.26
 D/B 09/1997⇒ S/N A814A02871A..... 4.28
 S/N A814A02872A⇒..... 4.30
 WITHOUT BWI
 ⇒D/B 09/1997 4.32
 D/B 09/1997⇒ S/N A814A02871A..... 4.34
 S/N A814A02872A⇒..... 4.36
 STEERING POD
 ⇒S/N A814A-01757V 4.4
 S/N A814A-01758V⇒ 4.6
 STEERING SYSTEM
 TRAIL AXLE..... 4.2
 STEERING TIRE AND WHEEL
 15 X 4.5 X 8 4.40
 16 X 6 X 8 4.42
 STROBE LIGHT 11.24

T

TILT CYLINDER 6.26
 TRACTION MOTOR
 ECONOMY TRUCK
 ⇒S/N A814A-02166W 2.72
 HIGH SPEED WITH BWI
 S/N A814A-02167W⇒ 2.76
 HIGH SPEED WITHOUT BWI
 S/N A814A-02167W⇒ 2.78
 IDLE SPEED WITH BWI
 S/N A814A-02167W⇒ 2.80
 PERFORMANCE TRUCK
 ⇒S/N A814A-02166W 2.74
 TRANSISTOR ASSEMBLY
 WITH BDI AND LIFT INTERRUPT
 ⇒S/N A814A-02166W 2.40
 WITHOUT BDI AND LIFT INTERRUPT
 ⇒S/N A814A-02166W 2.42
 TRANSISTOR CONTROL PANEL
 CONTACTOR HYDRAULIC
 ⇒S/N A814A-02166W 2.20
 TRANSISTOR HYDRAULIC
 ⇒S/N A814A-02166W 2.24
 TRANSISTOR CONTROLLER
 PUMP..... 2.44

DESCRIPTION	PAGE NO.
T (continued)	
TRANSMISSION	3.4
W	
WHEEL AND TIRE	
LUG TREAD ELECTRIC COMPOUND	3.16
NON-MARKING COMPOUND.....	3.12
SMOOTH TREAD	3.10
SMOOTH TREAD POLYURETHANE	3.14
WIRE HARNESS	
CONTROL VALVE	
S/N A814A-02167W⇒	2.122
DASH DISPLAY	2.102
FRAME	
⇒S/N A814A-01762V	2.106
S/N A814A-01763V⇔S/N A814A-02166W	2.108
HAND LEVER	
CONTACTOR HYDRAULIC	
⇒S/N A814A-02166W	2.112
TRANSISTOR HYDRAULIC	
⇒S/N A814A-02166W	2.114
INSTRUMENT CLUSTER	
CONTACTOR HYDRAULIC	
⇒S/N A814A-02166W	2.100
SHEET 1 OF 2	
⇒S/N A814A-02166W	2.96
SHEET 2 OF 2	
⇒S/N A814A-02166W	2.98
LIGHT	
OPTIONAL	
S/N A814A02167W⇒	11.30
S/N A814A-02167W⇒	2.104
⇒S/N A814A02166W.....	11.28
MAIN	
⇒S/N A814A-02166W	2.120
SCR CONTROL	
⇒S/N A814A-02166W	2.116
TRANSISTOR CONTROL PANEL	
S/N A814A-01763V⇔S/N A814A-02166W	2.118
ON-DEMAND STEERING	
⇒S/N A814A-02166W	2.94
STEERING MOTOR	
⇒S/N A814A-02166W	2.110
WORK AND REAR DRIVE LIGHTS.....	11.22

1	GENERAL TRUCK
---	---------------

**SECTION 1
GENERAL TRUCK**

DESCRIPTION	PAGE
ACCELERATOR	1.18
COUNTERWEIGHT	1.24
COVERS	1.34
FOOT DIRECTIONAL CONTROL PEDAL	
S/N A814A02167W⇒	1.20
FRAME	1.36
FULL SUSPENSION SEAT	
D/B 12/2000⇒	1.9
HOOD	1.30
LABELS	1.23
LIFT TRUCK	1.2
NON-SUSPENSION SEAT	
D/B 08/1998⇒	1.4
SEARS	
D/B 08/1998⇒	1.14
⇒D/B 08/1998	1.12
OVERHEAD GUARD	
D/B 06/1996⇒	1.28
⇒D/B 06/1996	1.26
SEAT ASSEMBLY	
SCHNEIDER	1.16
SEMI-SUSPENSION SEAT	1.6

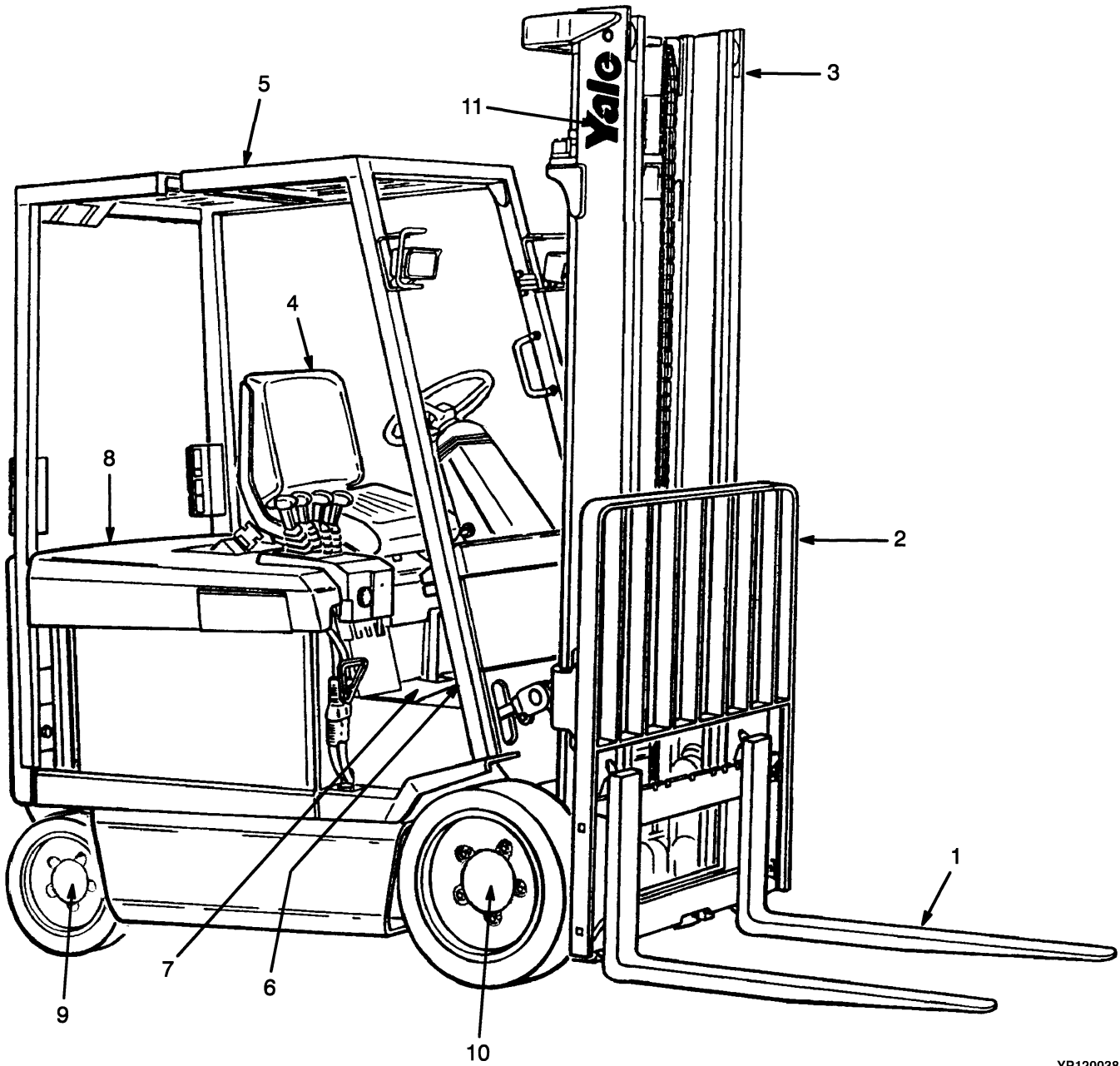

YP120038

ITEM	PART NO.	DESCRIPTION	QTY
1	Fork (☞ Page 10.6, ☞ Page 10.8)	2
2	Load Backrest Extension (☞ Page 10.2)	1
3	Mast-Two Stage Limited Free-Lift (☞ Page 7.2)	1
3	Mast-Two Stage Full Free-Lift (☞ Page 9.2)	1
3	Three Stage Full Free-Lift (☞ Page 8.2)	1
4	Seat (☞ Page 1.4, ☞ Page 1.6)	1
5	Overhead Guard (☞ Page 1.26, ☞ Page 1.28)	1
6	Accelerator Pedal (☞ Page 1.18)	1
7	Cowl and Floor Plates (☞ Page 1.34, ☞ Page 1.36)	1
8	Counterweight (☞ Page 1.24)	1
9	Trail Axle (☞ Page 4.2)	1
10	Drive Axle (☞ Page 3.2)	1
11	Label (☞ Page 1.22)	AR

NON-SUSPENSION SEAT (D/B 08/1998⇒)

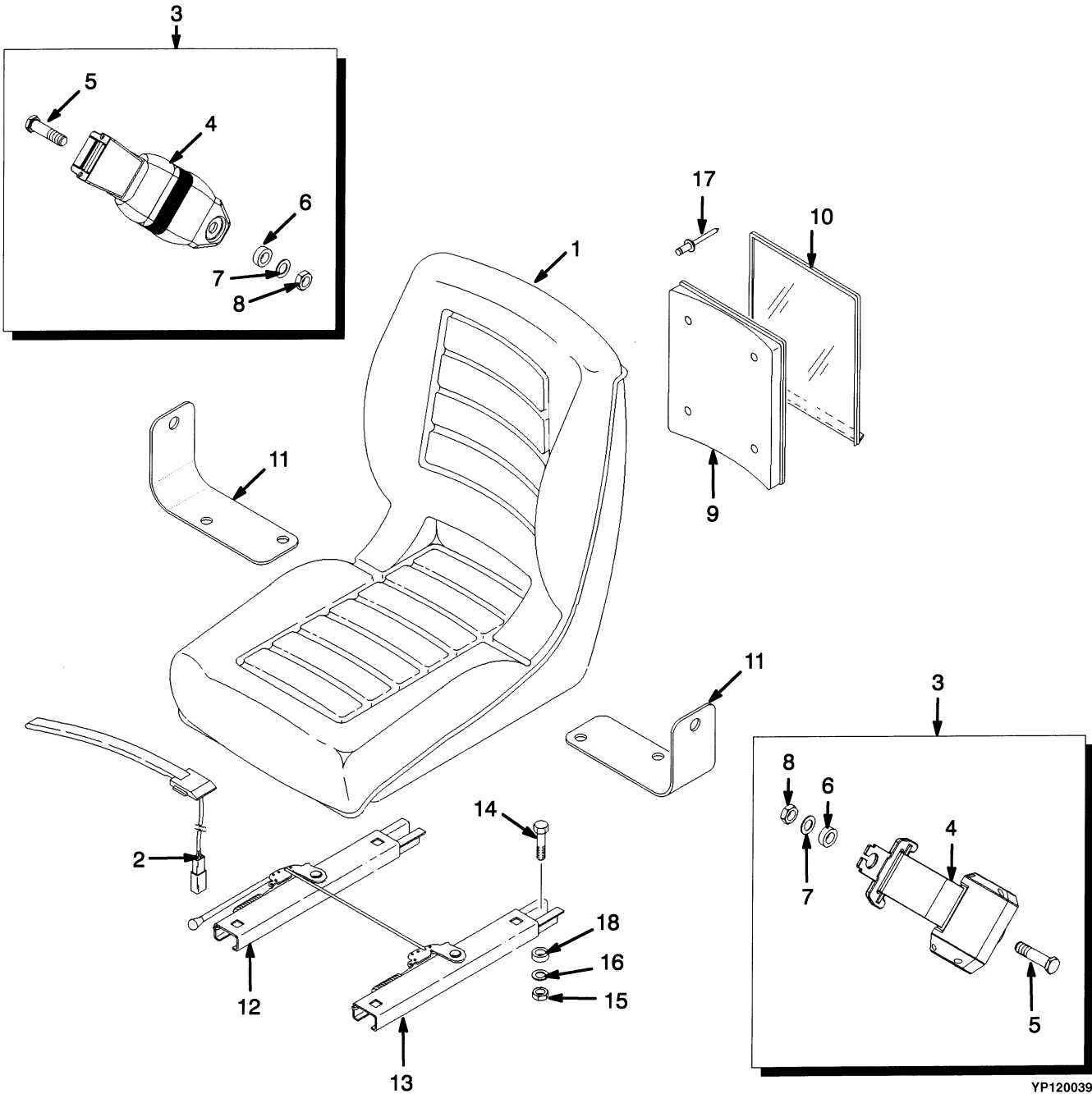

YP120039



NON-SUSPENSION SEAT
(D/B 08/1998⇒)

ITEM	PART NO.	DESCRIPTION	QTY
	580008424	Non-Suspension Seat.....	1
1	504232248	Seat.....	1
2	504305734	Switch Assembly.....	1
3	580010327	Seat Belt Kit.....	1
4	Seat Belt.....	1
5	Screw.....	2
6	Washer.....	2
7	Washer.....	2
8	Nut.....	2
9	519996801	Base (Information Case).....	1
10	519996803	Cover (Information Case).....	1
11	580014487	Bracket.....	2
12	580014485	Seat Rail.....	1
13	580014486	Seat Rail.....	1
14	a 449001014	Capscrew.....	4
14	b 062143700	Capscrew.....	4
15	504238298	Nut.....	4
16	023604600	Washer.....	4
17	Rivet.....	4
18	a 520052862	Spacer.....	4
18	b 580022641	Spacer.....	4
18	520044851	Spacer (Optional).....	4

FOOTNOTES:

a ⇒ D/B 10/2000

b D/B 10/2000 ⇒

SEMI-SUSPENSION SEAT

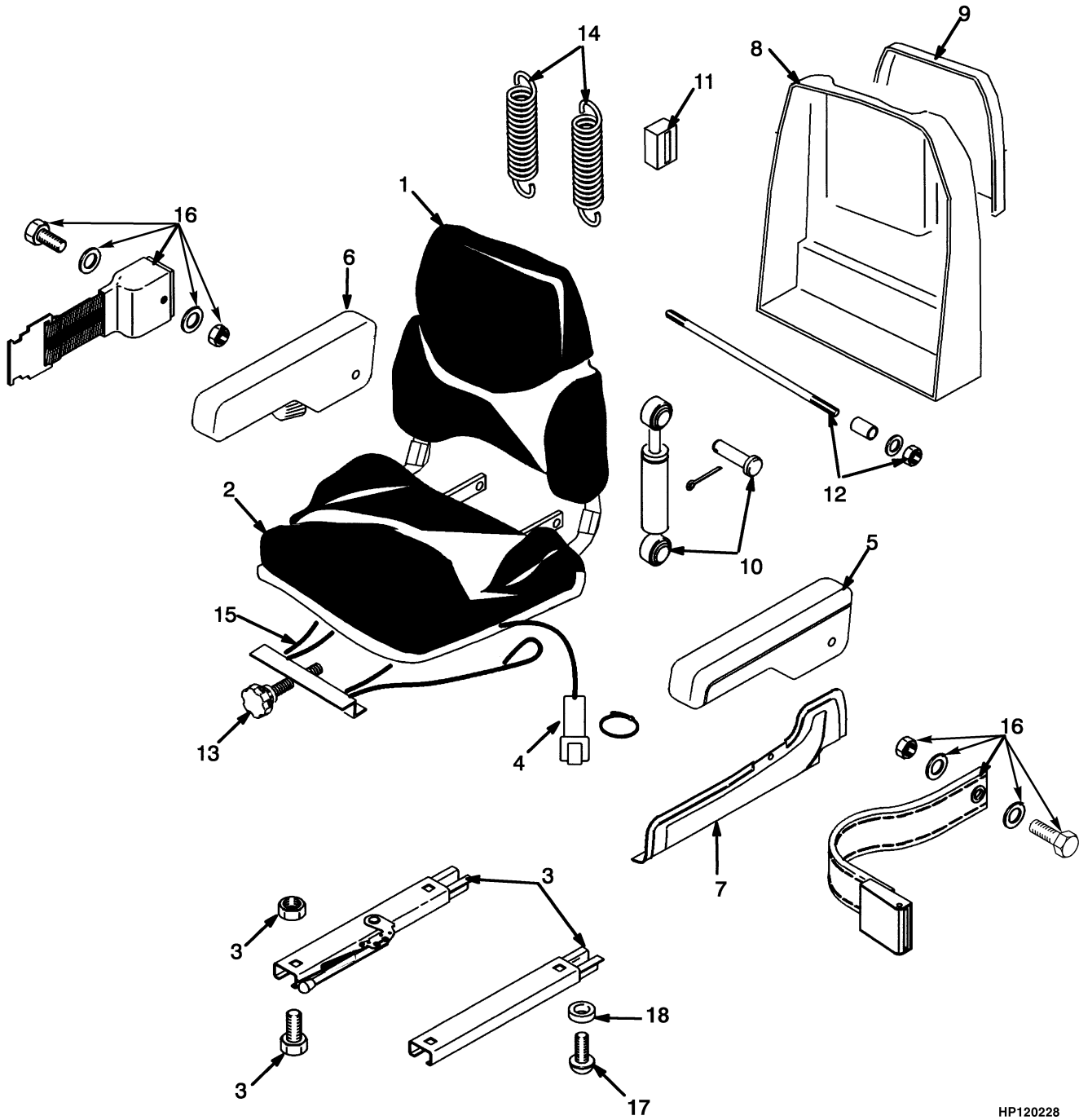

HP120228



SEMI-SUSPENSION SEAT

KEY:

A: Vinyl

B: Fabric

ITEM	PART NO.	DESCRIPTION	QTY	
			A	B
	258982303	Semi-Suspension Seat	1	..
	258982304	Semi-Suspension Seat	1
1	580002283	Back Cushion	1	..
1	524139404	Back Cushion	1
1	504289704	Back Cushion (Optional)	1	..
1	504289706	Back Cushion (Optional)	1
2	580002282	Seat Cushion.....	1	..
2	524139405	Seat Cushion.....	..	1
2	504289705	Seat Cushion (Optional).....	1	..
2	504289707	Seat Cushion (Optional).....	..	1
3	580010586	Seat Rail Kit	1	1
4	518793606	Switch Assembly	1	1
5	580010467	Armrest (LH) (LH).....	1	1
6	580010468	Armrest (RH) (RH)	1	1
7	580008948	Cover (LH).....	1	1
7	580008947	Cover (RH)	1	1
8	580010679	Cover (Back)	1	1
9	580010469	Holder (Operating Manual).....	1	1
10	520041836	Shock Absorber Kit	1	1
11	520041870	Block	1	1
12	520041896	Shaft and Bearing Kit	1	1
13	520041829	Knob Kit.....	1	1
14	520041644	Suspension Spring Kit.....	1	1
15	520041883	Suspension Cable Kit.....	1	1
16	580010327	Seat Belt Kit	1	1
17	530018801	Capscrew.....	4	4
18	520052862	Spacer	4	4
18	520044851	Spacer (Optional)	4	4

FULL SUSPENSION SEAT (D/B 12/2000⇒)

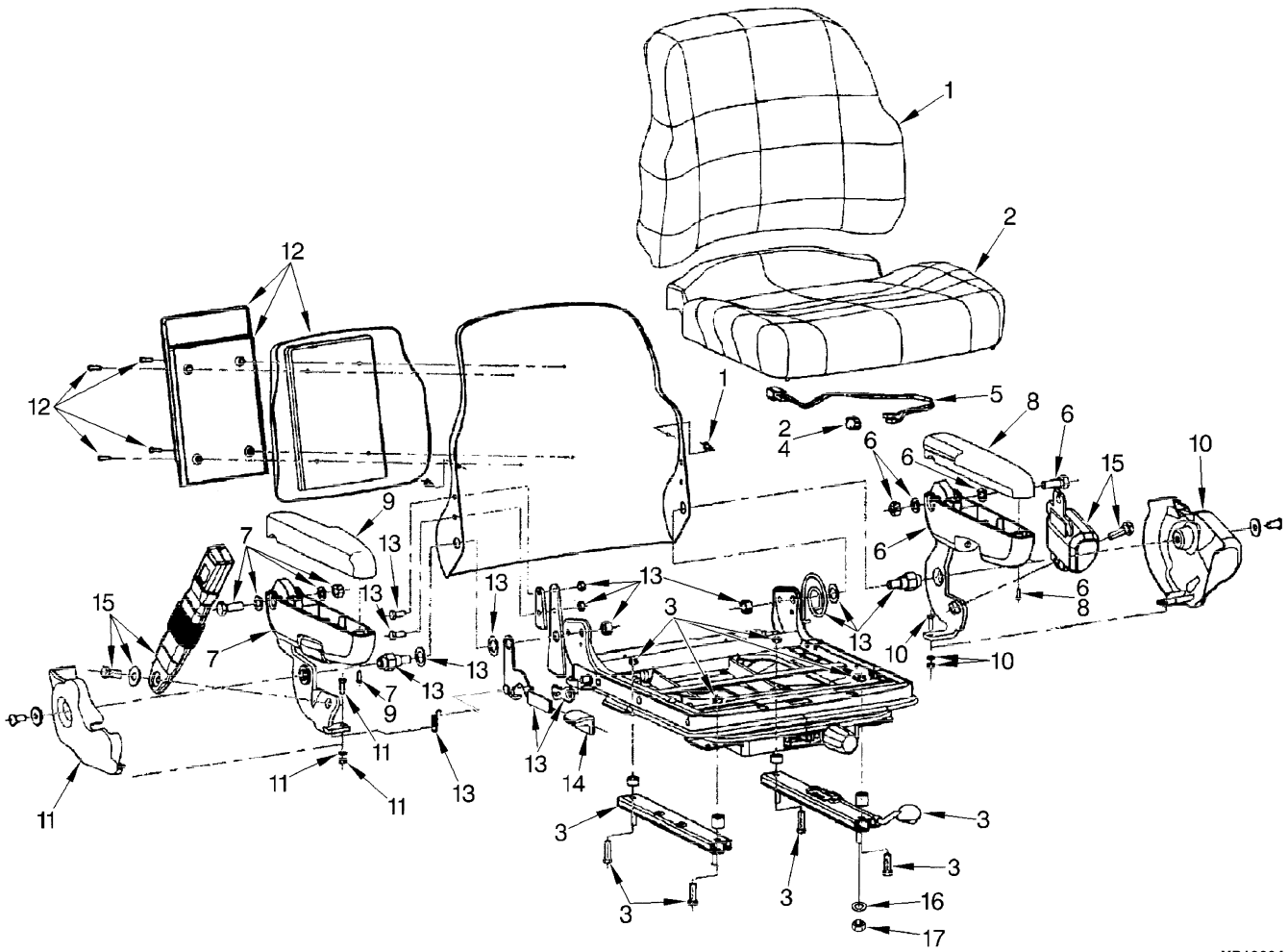

YP120041

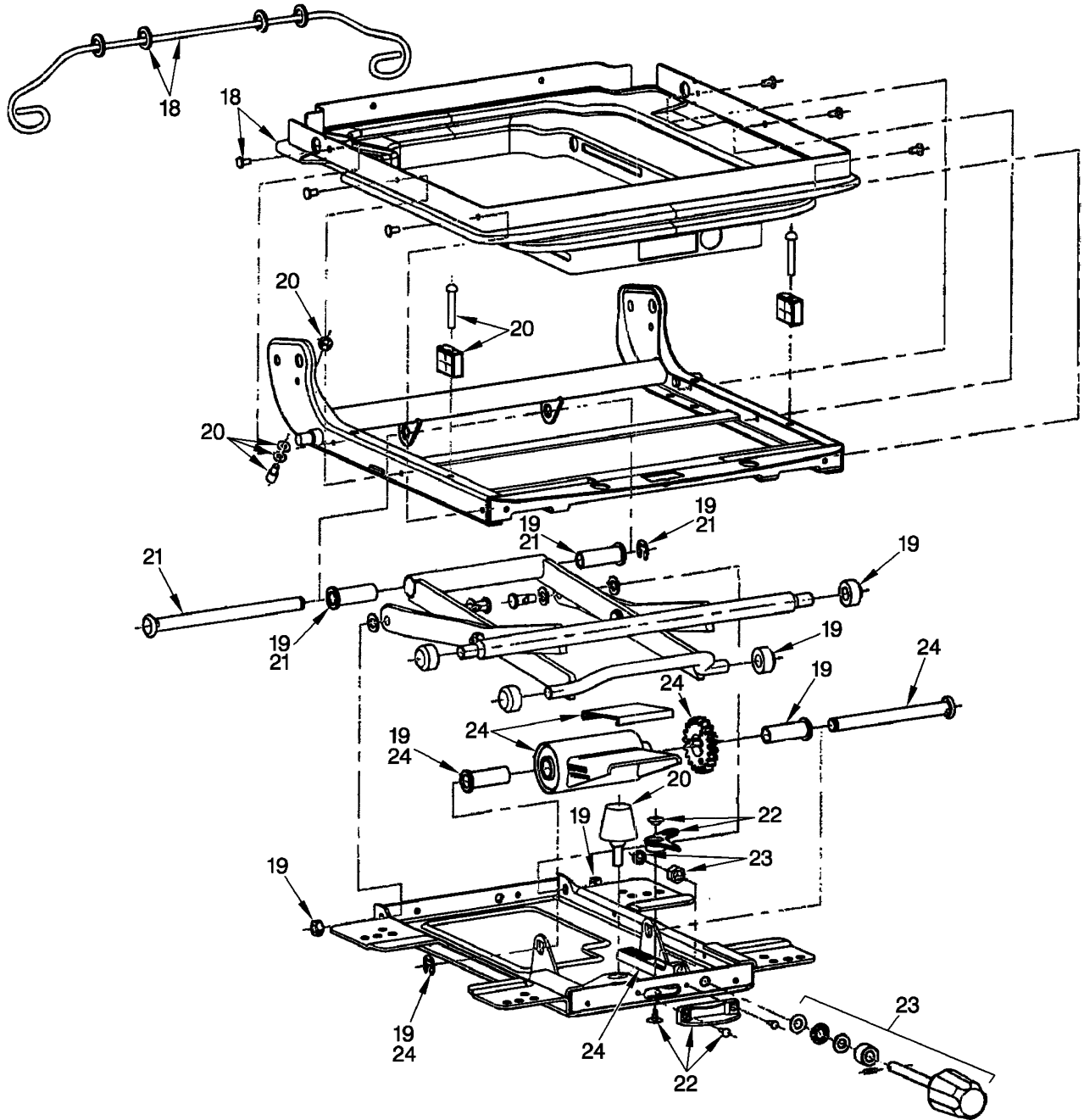

YP120042

FULL SUSPENSION SEAT
(D/B 12/2000⇒)

ITEM	PART NO.	DESCRIPTION	QTY
	524139223	Full Suspension Seat (Vinyl)	1
	524139224	Full Suspension Seat (Fabric)	1
1	524139579	Back Cushion (Vinyl)	1
1	524139580	Back Cushion (Fabric)	1
2	524139581	Seat Cushion (Fabric)	1
2	580013429	Seat Cushion (Vinyl)	1
3	580013409	Slider Kit	1
4	580013410	Switch	1
5	580013411	Wire Harness	1
6	580013412	Armrest (LH) (LH)	1
7	580013413	Armrest (RH) (RH)	1
8	580013414	Cap (LH)	1
9	580013415	Cap (RH)	1
10	580013416	Cover (LH)	1
11	580013417	Cover (RH)	1
12	580013418	Holder Kit	1
13	580013426	Recliner Kit	1
14	580013427	Recliner Knob	1
15	580013428	Seat Belt Kit	1
16	023604600	Washer	4
17	504238289	Grommet	4
18	580013419	Boot Kit	1
19	580013420	Roller and Bearing Kit	1
20	580013421	Bumper and Stop Kit	1
21	580013422	Bearing Shaft Kit	1
22	580013423	Weight Adjuster Indicator Kit	1
23	580013424	Knob Kit	1
24	580013425	Suspension Spring Kit	1

NON-SUSPENSION SEAT
(SEARS)
(⇒D/B 08/1998)

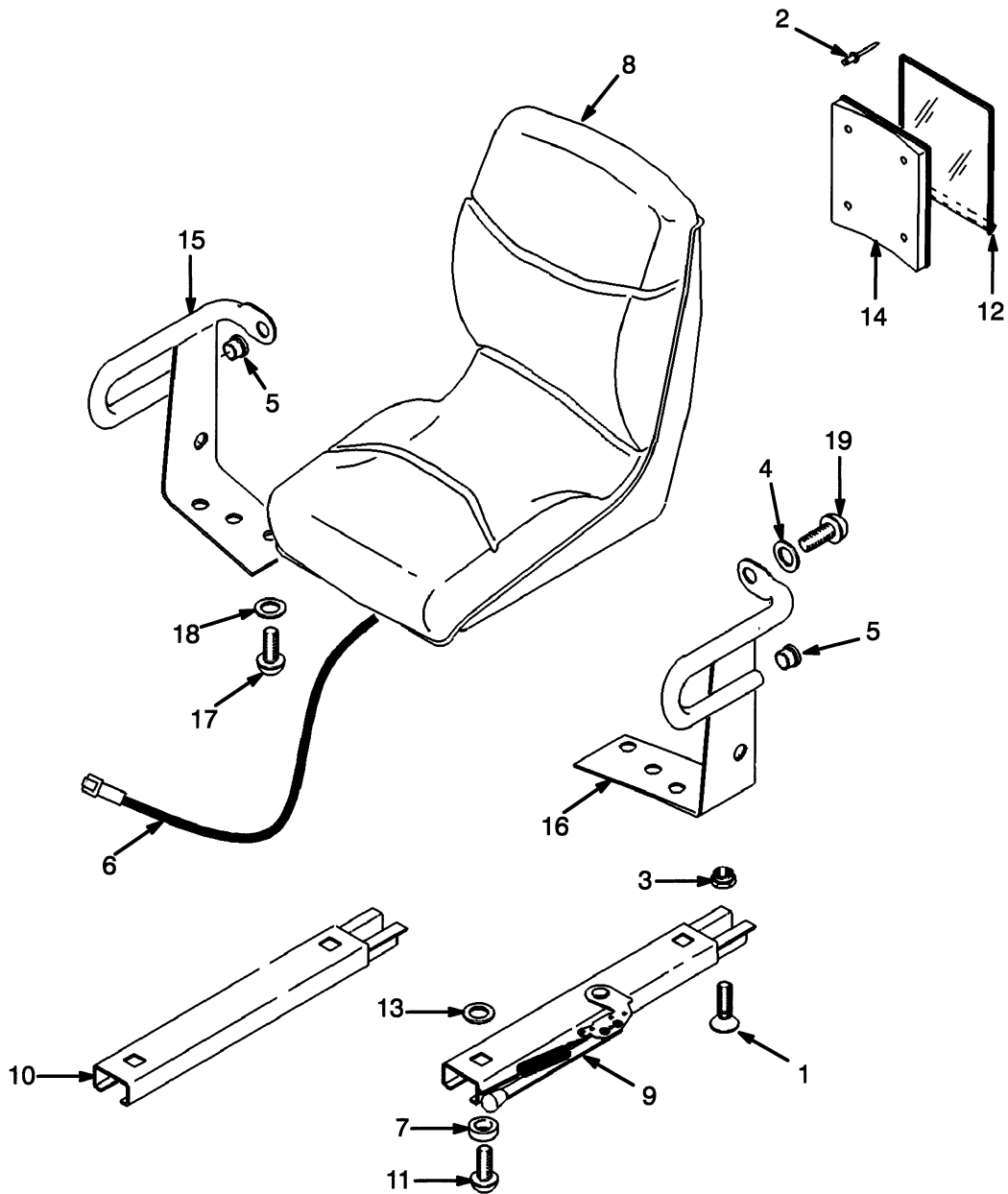

YP120043

ITEM	PART NO.	DESCRIPTION	QTY
1	520042809	Capscrew.....	4
2	501904909	Rivet	4
3	504227297	Nut.....	4
4	504239228	Washer	2
5	504226209	Plug	2
6	518793606	Switch Assembly	1
7	520052862	Spacer	4
8	504268740	Seat (Vinyl)	1
8	504268741	Seat (Fabric).....	1
9	505974541	Seat Rail (LH) (LH)	1
10	505974582	Seat Rail (RH) (RH).....	1
11	530018801	Capscrew.....	4
12	519996803	Cover (Information Case)	1
13	504233267	Washer	8
14	519996801	Base (Information Case).....	1
15	518793655	Hip Restraint (RH)	1
16	518793623	Hip Restraint (LH).....	1
17	501753902	Capscrew.....	4
18	016103700	Washer	4
19	504239208	Capscrew.....	2

**NON-SUSPENSION SEAT
(SEARS)
(D/B 08/1998⇒)**

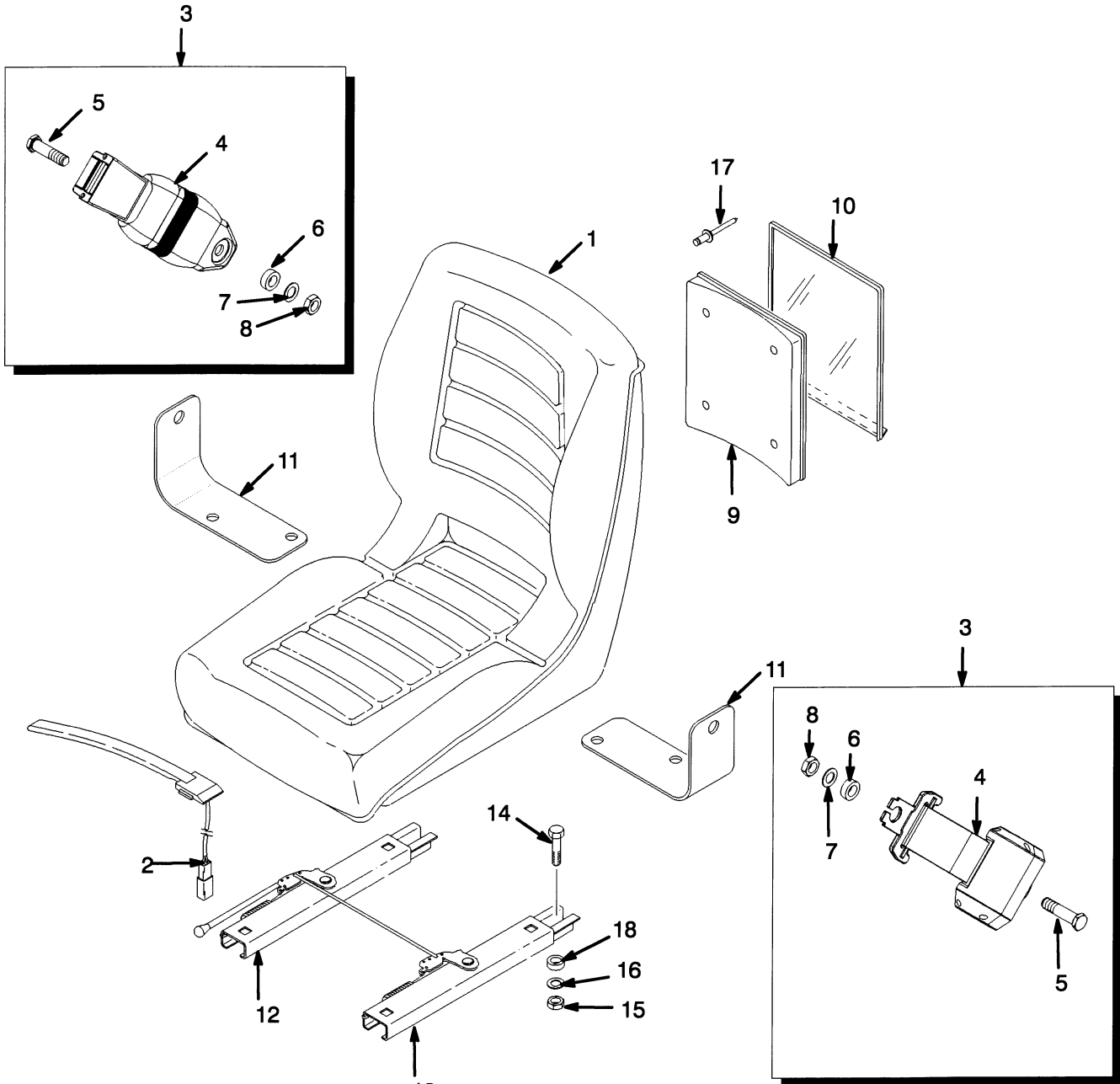

YP120044



NON-SUSPENSION SEAT
(SEARS)
(D/B 08/1998⇒)

ITEM	PART NO.	DESCRIPTION	QTY
	580008424	Non-Suspension Seat.....	1
1	504232248	Seat.....	1
2	504305734	Switch Assembly.....	1
3	580010327	Seat Belt Kit.....	1
4	Seat Belt.....	1
5	Screw.....	2
6	Washer.....	2
7	Washer.....	2
8	Nut.....	2
9	519996801	Base (Information Case).....	1
10	519996803	Cover (Information Case).....	1
11	580014487	Bracket.....	1
12	580014485	Seat Rail (RH).....	1
13	580014486	Seat Rail (LH).....	1
14	062306700	Capscrew.....	4
15	504238298	Nut.....	4
16	023604600	Washer.....	4
17	Rivet.....	4
18	520052862	Spacer.....	4
18	520044851	Spacer (Optional).....	4

Thank you so much for reading.
Please click the “Buy Now!”
button below to download the
complete manual.



After you pay.

You can download the most
perfect and complete manual in
the world immediately.

Our support email:

ebooklibonline@outlook.com