

Parts Manual
Catalogo Parti Ricambi
Manuel des Pièces de Rechange
Ersatzteilkatalog
Manual de Repuestos

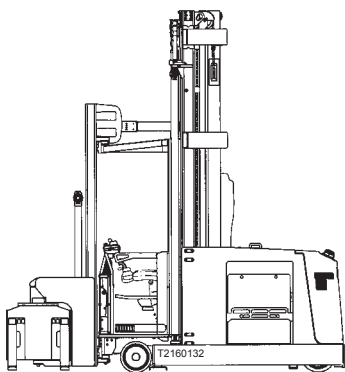

MTC13-13_{LWB}
NTA030SB



Specify the following information when ordering spare parts:
Per ordinare parti di ricambio specificare:
 Pour les commander les pièces détachées veuillez préciser:
 Zum Bestellen von Ersatzteilen bitte folgende Angaben machen:
 Para solicitar los repuestos especificar:

- truck model
- *tipo della macchina*
- type machine
- *Staplertyp*
- tipo de la máquina.

- table N°
- *N° della tavola*
- N° plan
- *Tafel-Nr.*
- N° de la máquina.

- quantity
- *quantità dei particolari richiesti*
- nombre de pièces
- *Erforderliche Stückzahl*
- cantidad de piezas solicitadas.

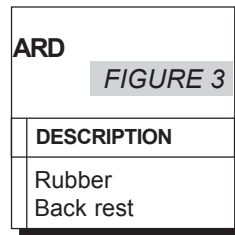
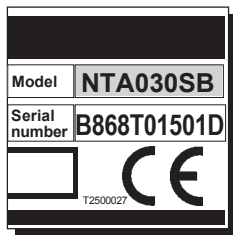

	Q.TY	DESCRI
00	1	Rubber
00	1	Back
55	4	Screw
31	4	Screw
51	8	Elastic
92	4	Washes

NTA030SB B868T01501D FIGURE 3 272315400 4 Screw

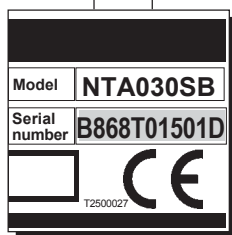

EF.	PART NO.
1	277102000
2	272315400
3	580033000
4	277213400
5	277121300

Q.TY	DESCRIPTION
1	Rubber
1	Back rest
4	Screw
4	Screw
8	Elastic wash

- truck serial number
- *matricola della macchina*
- N° matricule
- *Seriennummer der Maschine*
- matricula de la máquina.

- part number of required component
- *N° di codice del particolare richiesto*
- N° code de la pièce
- *Best. Nr. des erforderlichen Teils*
- N° de código de la pieza solicitada.

- part description
- *demoninazione del particolare richiesto*
- désignation de la pièce
- *Bezeichnung des erforderlichen Teils*
- denominación de la pieza solicitada.

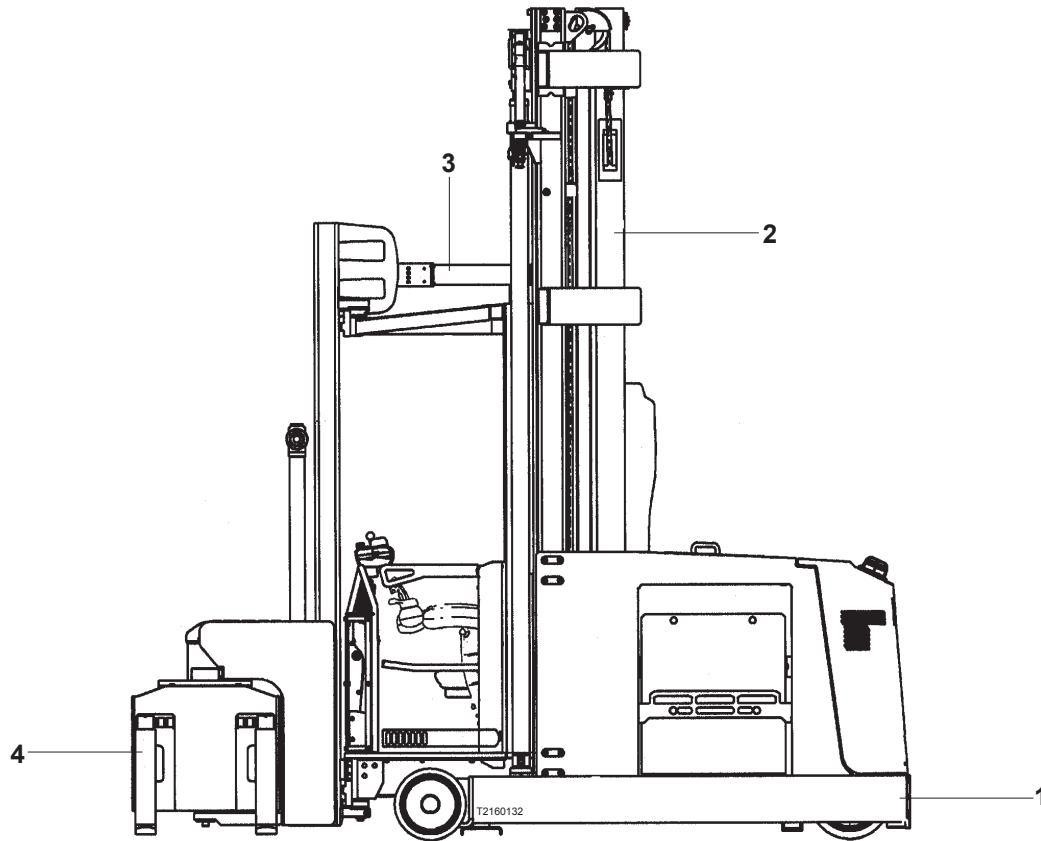

REF.	DIVISION / SEZIONE / SECTION / SEKTION / DIVISIÓN	PAGE NO.
1	FRAME / CARRO / CHÂSSIS / RAHMEN / BASTIDOR	6
2	MAST / MONTANTE / MONTANT / PFOSTEN / MONTANTE	62
3	OPERATOR'S COMPARTMENT / CABINA / CABINE / KABINE / CABINA	94
4	TRILATERAL ATTACHMENT / ATTREZZATURA TRILATERALE / ACCESSOIRE TRILATERAL / ZUBEHÖRTEILE / ACCESSORIO TRILATERAL	146
5	ACCESSORIES / ACCESSORI / ACCESSOIRES / ZUBEHÖR / ACCESSORIOS	174

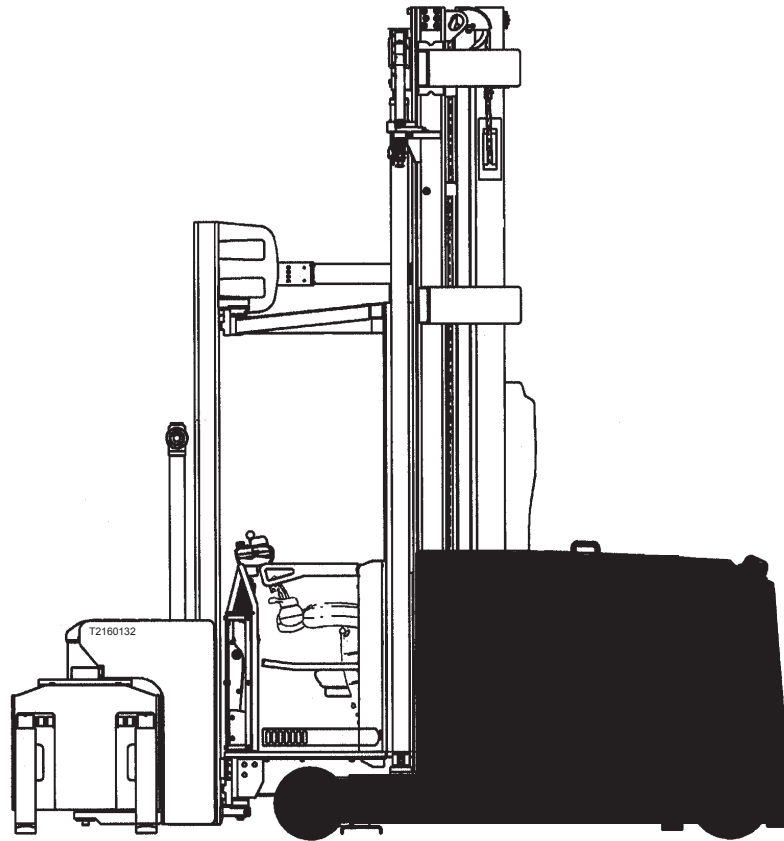

DIVISION 1

DESCRIPTION / DESCRIZIONE / DESIGNATION / BENENNING / DENOMINACIONES	PAGE NO.
FRAME / TELAIO / CHÂSSIS / RAHMEN / BASTIDOR FIGURE 1A	8-9
REAR COVERS-BATTERY COVER/ COPERCHI POSTERIORI -COPERCHIO BATTERIA/ COUVERCLE POSTÉRIEUR-COUVERCLE BATTERIE / ABDECKUNG (RÜCKWÄRTS)-BATTERIEABDECKUNG / TAPA POSTERIOR-TAPA DE LA BATERÍA FIGURE 2A	10-11
BATTERY COMPARTMENT / SCOMPARTIMENTO BATTERIA / LOGEMENT DE LA BATTERIE / BATTERIEKASTEN / COMPARTIMENTO DE LA BATERÍ - MODELS MTC13-NTA030SB (Frame 2) - FIGURE 3.1A	12-13
BATTERY COMPARTMENT / SCOMPARTIMENTO BATTERIA / LOGEMENT DE LA BATTERIE / BATTERIEKASTEN / COMPARTIMENTO DE LA BATERÍ - MODELS MTC13LWB-NTA030SB (Frame 3) - FIGURE 3.2A	14-15
SIDE ROLLERS GUIDE / RULLI LATERALI DI GUIDA / ROULEAUX LATÉRAUX GUIDE / SEITLICHE FÜHRUNGSROLLE / RODILLOS LATERAL DE GUIA - OPTION - FIGURE 4A	16-17
FRONT ROLLERS GUIDE / RULLI FRONTALI DI GUIDA / ROULEAUX ANTÉRIEUR GUIDE / FRONTAL FÜHRUNGSROLLE / RODILLOS FRONTALDE GUIA - OPTION - FIGURE 5A	18-19
LOAD WHEELS / RUOTE DI CARICO / ROUES DE CHARGEMENT / BESCHICKUNGSRÄDER / RUEDAS DE CARGA FIGURE 6A	20-21
COVER WHEELS / PROTEZIONE RUOTE / PROTECTION ROUES / SCHUTZABDECKUNG RÄDER / PROTECCIÓN RUEDAS - OPTION - FIGURE 7A	22-23
DRIVE UNIT / GRUPPO TRAZIONE - STERZO / GROUPE DE TRACTION - DIRECTION / ZUGAGGREGAT-EINHEIT MOTOR LENKUNG / GRUPO DE TRACCION - DIRECCIÓN FIGURE 8A	24-25
REDUCTION UNIT / RIDUTTORE / RÉDUCTEUR / GETRIEBEMOTOR / REDUCTOR - GK30 - FIGURE 9A	26-27
REDUCTION UNIT / RIDUTTORE / RÉDUCTEUR / GETRIEBEMOTOR / REDUCTOR - GK40 - FIGURE 9.1A	28-29
DRIVE MOTOR / MOTORE DI TRAZIONE / MOTEUR DE TRACTION / ZUGMOTOR / MOTOR DE TRACCION FIGURE 10A	30-31
ELECTROMAGNETIC BRAKE / FRENO ELETTROMAGNETICO / FREIN ÉLECTROMAGNETIQUE / ELEKTROMATISCHE BREMSE / FRENO ELECTROMAGNÉTICO FIGURE 11A	32-33
STEERING MOTOR / MOTORIDUTTORE STERZO / MOTOREDUCTEUR DIRECTION / MOTORVERMINDERER FÜR ELEKTRISCHE LENKUNG / MOTOREDUCTOR DIRECCION - MODELS WITH GK30 - FIGURE 12A	34-35
STEERING MOTOR / MOTORIDUTTORE STERZO / MOTOREDUCTEUR DIRECTION / MOTORVERMINDERER FÜR ELEKTRISCHE LENKUNG / MOTOREDUCTOR DIRECCION - MODELS WITH GK40 - FIGURE 12.1A	36-37
HYDRAULIC GROUP / GRUPPO IDRAULICO / INSTALLATION HYDRAULICA / HYDRAULIKANLAGE / INSTALACION HIDRAULICA FIGURE 13A	38-41
LIFT MOTOR AND PUMP / MOTORE SOLLEVAMENTO E POMPA / MOTO POMPE SOULEVEMENT / MOTORPUMPE ZUR ANAEBUNG / MOTOBOMBA ELEVACIÓN FIGURE 14A	42-43
MANIFOLD MAIN / BLOCCO PRINCIPALE COMANDO CABINA / SOUPE PRINCIPAL / HAUPTVENTIL / VÁLVULA PRINCIPAL FIGURE 15A	44-45
HIGH PERFORMANCE LOWERING VALVE / VALVOLA DISCESA VELOCE CABINA / SOUPE DESCENTE RAPIDE CABINE / VENTIL SENKEN SCHNELL KABINE / VÁLVULA BAJADA RÁPIDA CABINA - OPTION - FIGURE 15.1A	46-47
MANIFOLD STABILISERS / BLOCCO COMANDO STABILIZZATORI / SOUPE STABILISATEURS / STABILISATORENVENTIL / VÁLVULA ESTABILIZADORES - OPTION - FIGURE 16A	48-49
ELECTRIC PANEL / QUADRO ELETTRICO / PANNEAU ÉLECTRIQUE / ELEKTRISCHE SCHALTAFEL / PANEL ELECTRICO FIGURE 17A	50-51
ELECTRICAL ARRANGEMENT (POWER CABLES) / IMPIANTO ELETTRICO (CAVI DI POTENZA) / INSTALLATION ÉLECTRIQUE (CABLES DE PUISSANCE) / ELEKTRISCHE (LEISTUNGKABEL) / INSTALACION ELECTRICA (CABLE DE POTENCIA) FIGURE 18A	52-53
ELECTRICAL ARRANGEMENT / IMPIANTO ELETTRICO / INSTALLATION ÉLECTRIQUE / ELEKTRISCHE / INSTALACION ELECTRICA FIGURE 19A	54-59
LABELS / TARGHETTE E ADESIVI / AUTOCOLLANTS DE SIGNALISATION / SELBSTKLEBESCHILDER / TARJETAS ADHESIVAS FIGURE 20A	60-61

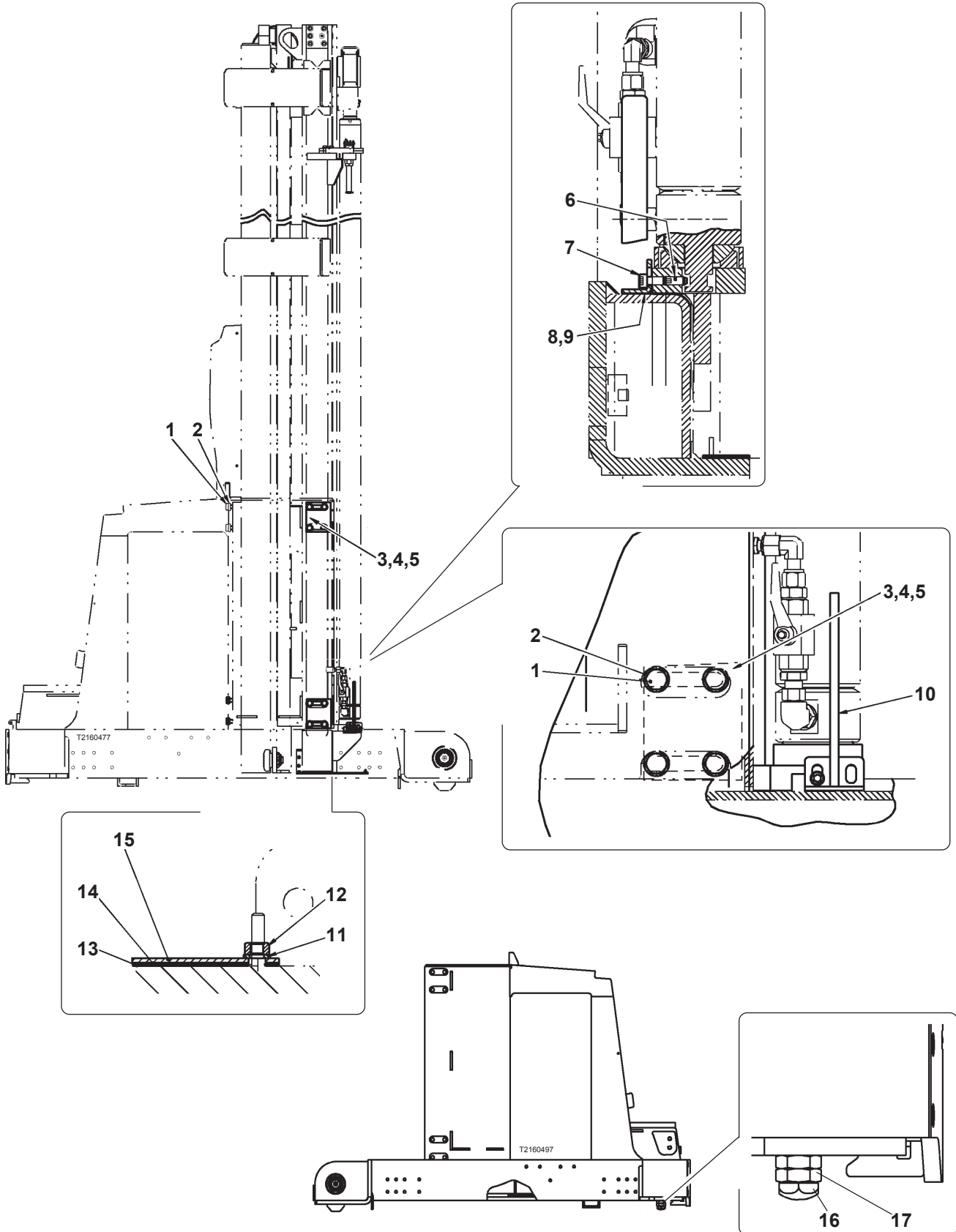

REF.	PART NO.	Q.TY	DESCRIPTION	DESCRIZIONE	DESIGNATION	BENENNUNG	DENOMINACIONES	PART DETAILS
1	311323021	24	Screw	Vite	Vis	Schraube	Tomillo	
2	449021019	24	Washer	Rondella	Rondelle	Unterlegscheibe	Arandela	
3	580071527	AR	Shim	Spessore	Entretoise	Distanzstück	Espaciador	0,5 mm
4	580071526	AR	Shim	Spessore	Entretoise	Distanzstück	Espaciador	1 mm
5	580071525	AR	Shim	Spessore	Entretoise	Distanzstück	Espaciador	2 mm
6	580010264	2	Screw	Vite	Vis	Schraube	Tomillo	
7	580026611	2	Screw	Vite	Vis	Schraube	Tomillo	
8	580058630	2	Plate	Piatto	Plaque	Teller	Plato	0,5 mm
9	580058631	2	Plate	Piatto	Plaque	Teller	Plato	1 mm
10	580069468	2	Cylinder rotation lock	Piatto	Plaque	Teller	Plato	
11	449021003	4	Washer	Rondella	Rondelle	Unterlegscheibe	Arandela	
12	504574259	4	Nut	Dado	Écrou	Mutter	Tuerca	
13	580071528	AR	Shim	Spessore	Entretoise	Distanzstück	Espaciador	0,5 mm
14	580071529	AR	Shim	Spessore	Entretoise	Distanzstück	Espaciador	1 mm
15	580071530	AR	Shim	Spessore	Entretoise	Distanzstück	Espaciador	2 mm
16	272506700	2	Screw	Vite	Vis	Schraube	Tomillo	
17	937701930	4	Nut	Dado	Écrou	Mutter	Tuerca	

From serial N° / *Da matr. /*
Du matr. / *Ab. seriennummer /*
Desde la matr. :

Until serial N° / *Fino a matr. /*
Jusq' matr. / *Bis zur serien-Nr. /*
Hasta la matr. :

With the exception of /
Ad esclusione di / À l'exclusion de /
Mit ausnahme von / Excepto :

Including / *Compreso / Avec /*
Einschließlich / Con :

B868T01501D

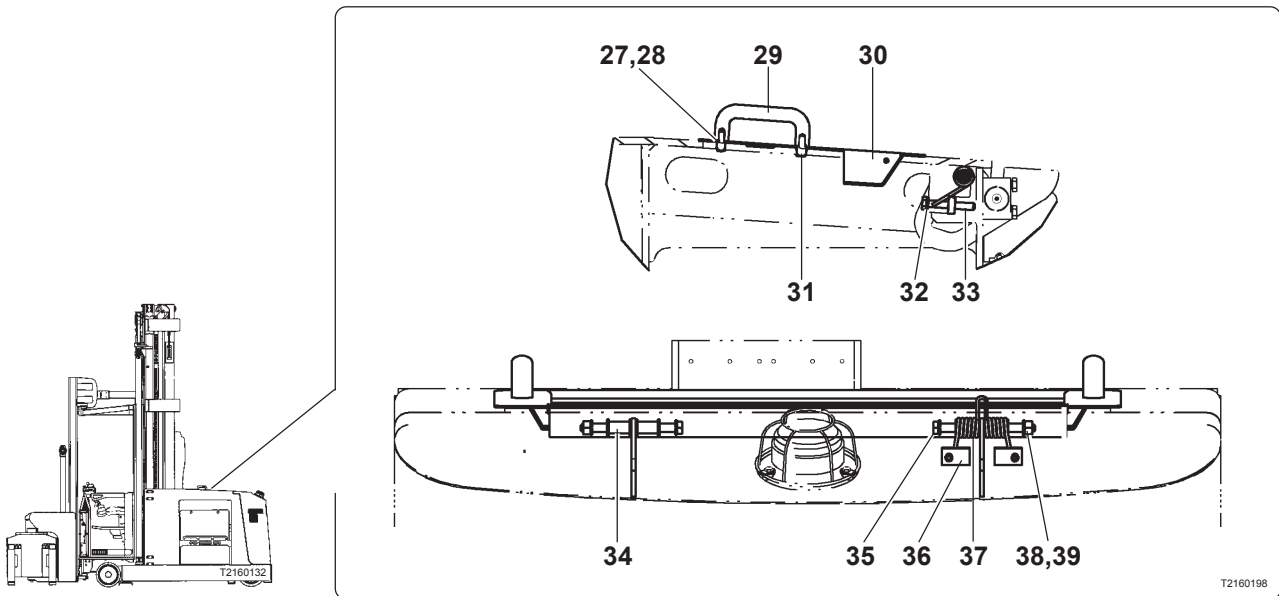
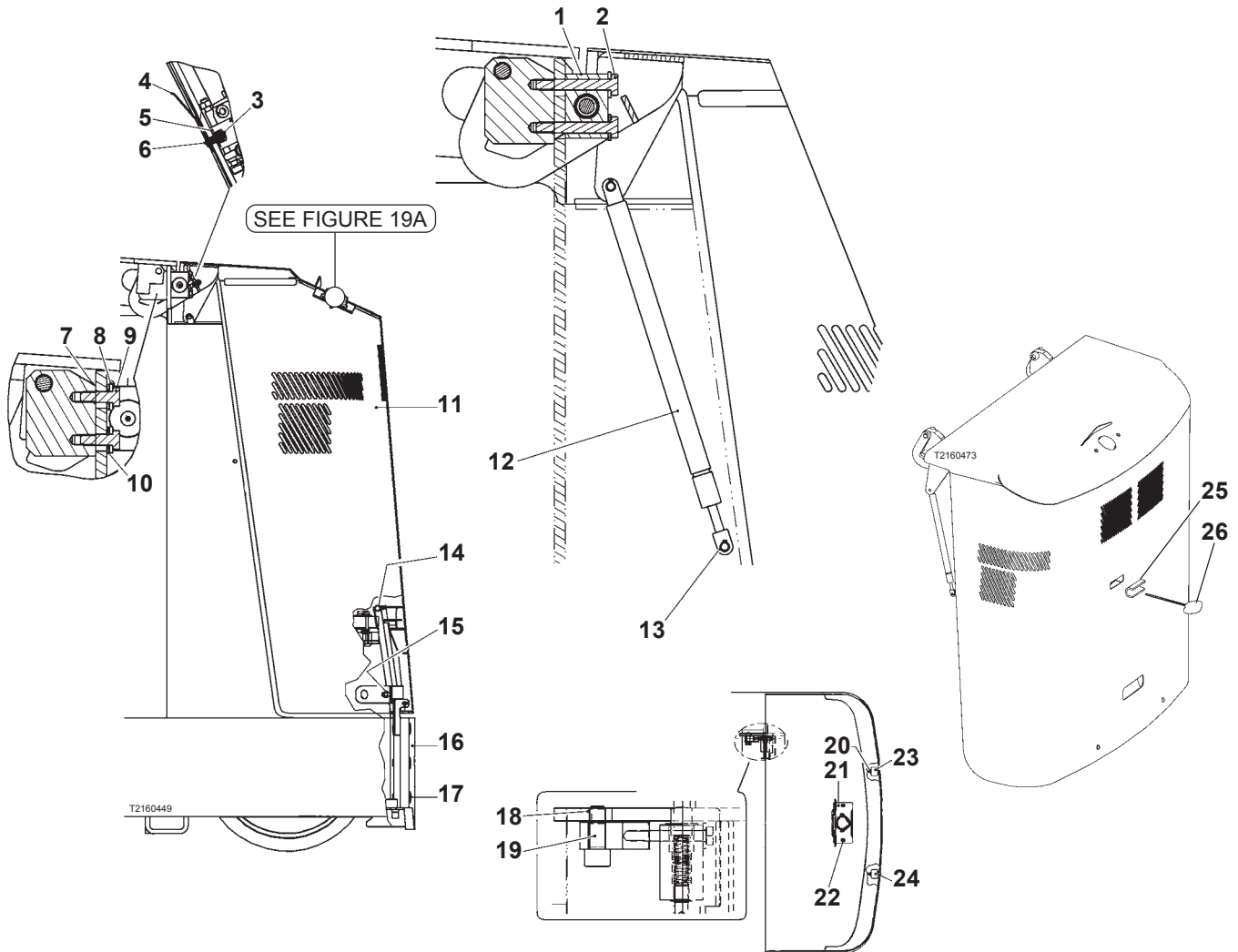

REAR COVERS - BATTERY COVER
 COPERCHI POSTERIORI - COPERCHIO BATTERIA
 COUVERCLE POSTÉRIEUR - COUVERCLE BATTERIE
 ABDECKUNG (RÜCKWÄRTS) - BATTERIEABDECKUNG
 TAPA POSTERIOR - TAPA DE LA BATERÍA

FIGURE 2A

REF.	PART NO.	Q.TY	DESCRIPTION	DESCRIZIONE	DESIGNATION	BENENNUNG	DENOMINACIONES	PART DETAILS
1	580055364	1	Safety block	Blocco di sicurezza	Bloc de sécurité	Block	Bloque de seguridad	
2	449001233	2	Screw	Vite	Vis	Schraube	Tornillo	
3	449015135	1	Nut	Dado	Écrou	Mutter	Tuerca	
4	272347600	1	Plate	Piatto	Plaque	Teller	Plato	
5	580017101	1	Washer	Rondella	Rondelle	Unterlegscheibe	Arandela	
6	518791613	1	Screw	Vite	Vis	Schraube	Tornillo	
7	580051530	2	Cover support	Supporto coperchio	Support couvercle	Lager	Soporte tapa	
8	504071785	4	Washer	Rondella	Rondelle	Unterlegscheibe	Arandela	
9	449001302	2	Screw	Vite	Vis	Schraube	Tornillo	
10	449021010	2	Washer	Rondella	Rondelle	Unterlegscheibe	Arandela	
11	524230452	1	Cover	Coperchio	Couvercle	Batterieabdeckung	Tapa de la batería	
12	580058256	2	Gas spring	Asta gas	Tige gaz	Gasschiene	Varilla del gas	
13	15914400	4	Snap ring	Seeger	Arretoi	Seeger	Anillo Seeger	
14	580058376	1	Gasket	Guarnizione	Joint	Dichtung	Junta	
15	449015098	2	Nut	Dado	Écrou	Mutter	Tuerca	
16	524229865	1	Plate	Piastra	Plaque	Platte	Plancha	
17	272022800	6	Screw	Vite	Vis	Schraube	Tornillo	
18	580051582	2	Bushing	Boccola	Douille	Buchse	Casquillo	
19	580051531	2	Cover screw	Vite	Vis	Schraube	Tornillo	
20	449021001	4	Washer	Rondella	Rondelle	Unterlegscheibe	Arandela	
21	580068231	1	Bent plate	Piastra	Plaque	Platte	Plancha	
22	272342200	2	Nut	Dado	Écrou	Mutter	Tuerca	
23	277533300	2	Vibration damping	Antivibrante	Antivibrant	Schwingungsdamp	Antivibrador	
24	580032377	2	Screw	Vite	Vis	Schraube	Tornillo	
25	580070744	1	Rubber	Gomma	Caoutchouc	Gummi	Goma	
26	580070743	1	Wrench	Chiave	Clef	Schlüssel	llave	
27	449022016	4	Washer	Rondella	Rondelle	Unterlegscheibe	Arandela	
28	449021001	4	Washer	Rondella	Rondelle	Unterlegscheibe	Arandela	
29	273034900	2	Handle	Manopola	Pomme	Griff	Perilla	
30	580058258	1	Cover	Coperchio	Couvercle	Batterieabdeckung	Tapa de la batería	MTC 13-MTC 13LWB-NTA030SB
31	580022964	4	Screw	Vite	Vis	Schraube	Tornillo	
32	449022013	2	Washer	Rondella	Rondelle	Unterlegscheibe	Arandela	
33	931014913	2	Screw	Vite	Vis	Schraube	Tornillo	
34	504064739	4	Spacer	Distanziale	Entretoise	Abstandhalter	Separador	
35	931015920	2	Screw	Vite	Vis	Schraube	Tornillo	
36	580057321	1	Plate	Piastra	Plaque	Platte	Plancha	
37	580057322	1	Spring torsion	Molla	Ressort	Feder	Resorte	
38	449022017	4	Washer	Rondella	Rondelle	Unterlegscheibe	Arandela	
39	580033885	2	Nut	Dado	Écrou	Mutter	Tuerca	

From serial N° / Da matr. /
 Du matr. / Ab. seriennummer /
 Desde la matr. :

Until serial N° / Fino a matr. /
 Jusq' matr. / Bis zur serien-Nr. /
 Hasta la matr. :

With the exception of /
 Ad esclusione di / À l'exclusion de /
 Mit ausnahme von / Excepto :

Including / Compreso / Avec /
 Einschließlich / Con :

B868T01501D

Thank you so much for reading.
Please click the “Buy Now!”
button below to download the
complete manual.



After you pay.

You can download the most
perfect and complete manual in
the world immediately.

Our support email:

ebooklibonline@outlook.com