

Truck model / Carrello tipo / Chariot modele / Staplertyp / Tipo de carretilla
MP16 / MP18 / MP20

Part No: 5241171926 (09-2006)

From Serial No: C841X01501A

Parts Manual
Catalogo Parti Ricambi
Manuel des Pièces de Rechange
Ersatzteilkatalog
Manual de Repuestos

MP16-MP18
MP20



Specify the following information when ordering spare parts:

- truck model;
- truck serial number;
- table N°;
- part number of required component;
- quantity;
- part description

Per ordinare parti di ricambio specificare:

- tipo della macchina;
- matricola della macchina;
- n° della tavola;
- numero di codice del particolare richiesto;
- quantità di particolari richiesti;
- denominazione del particolare richiesto.

Pour les commander les pièces détachées veuillez préciser:

- type machine;
- n° matricule;
- n° plan;
- n° code de la pièce;
- nombre de pièces;
- désignation de la pièce.

Zum Bestellen von Ersatzteilen bitte folgende Angaben machen:

- Staplertyp;
- Seriennummer der Maschine;
- Tafel-Nr.;
- Best. Nr. des erforderlichen Teils;
- Erforderliche Stückzahl;
- Bezeichnung des erforderlichen Teils.

Para solicitar los repuestos especificar:

- tipo de la máquina;
- matrícula de la máquina;
- n° de la máquina;
- número de código de la pieza solicitada;
- cantidad de piezas solicitadas;
- denominación de la pieza solicitada.

PART SHEET INDEX - INDICE DELLE TAVOLE - INDEX DES TABLES - TAFELVERZEICHNIS - INDICE DE TABLAS	PAGE NO.
COVERS / CARTER / COUVERCLE / DECKEL / TAPAS (SHEET 1.A)	4
ADHESIVE LABELS / TARGHETTE ADESIVE / AUTOCOLLANTS DE SIGNALISATION / ABZ.-BILD / ADESIVOS DE AVISO (SHEET 2.A)	6-7
FRAME BATTERY VERTICAL REMOVAL / TELAIO BATTERIA ESTRAZIONE VERTICALE / CHASSIS BATTERIE VERTICAL EXTRACTION / BATTERIEWECHSEL KONVENTIONELLE BATTERIE ENDHAME / BASTIDOR BATERIA EXTRACCION VERTICAL (SHEET 3.A)	8-11
SUPPORTS AND CASTER WHEELS / SUPPORTI E RUOTE PIROETTANTI / SUPPORTS ET ATTELAGE / LAGERN UND RÄDER / SOPORTE Y RUEDAS (SHEET 4.A)	12-13
LOAD WHEELS / RUOTE DI CARICO / ATTELAGES / RÄDER / RUEDAS (SHEET 5.A)	14-15
TRACTION UNIT / GRUPPO TRAZIONE / GROUPE DE TRACTION / ZUGAGGREGAT / GRUPO DE TRACCION (SHEET 6.A).....	16-17
TRACTION MOTOR (MP16/MP18) / MOTORE TRAZIONE (MP16/MP18) / MOTEUR TRACTION (MP16/MP18) / ZUGMOTOR (MP16/MP18) / MOTORE DE TRACCION (MP16/MP18)(SHEET 7.A)	18
TRACTION MOTOR (MP20) / MOTORE TRAZIONE (MP20) / MOTEUR TRACTION (MP20) / ZUGMOTOR (MP20) / MOTORE DE TRACCION (MP20)(SHEET 8.A)	19
MAGNETIC BRAKE / FRENO ELETTROMAGNETICO / FREIN ELETTROMAGN. / ELEKT ROMAGN. BREMSE / FRENO ELECTROM. (SHEET 9.A)	20
HYDRAULIC SYSTEM / IMPIANTO IDRAULICO / INSTALLATION HYDRAULIQUE / HYDRAULIKANLAGE / INSTALLACION HIDRAULICA (SHEET 10.A)	21
DRAWBAR CONTROL BOX / TIMONE SCATOLA COMANDI / BARRE BOITE DE COMMANDE / DEICHSEL STEUERUNGSBUCHSE (SHEET 11.A-11.B-11.C)	22-27

PART SHEET INDEX - INDICE DELLE TAVOLE - INDEX DES TABLES - TAFELVERZEICHNIS - INDICE DE TABLAS	PAGE NO.
DISTRIBUTOR / CENTRALINA IDRAULICA / DISTRIBUTEUR / STEUERUNG / DISTRIBUIDOR (SHEET 12.A)	28-29
BATTERY CHARGER (MP16) / CARICA BATTERIA (MP16) / CHARGUER (MP16) / AULFLADERÄT (MP16) / CARGADOR DE BATERIAS (MP16) (SHEET 13.A).....	30
BATTERY CHARGER (MP18/MP20) / CARICA BATTERIA (MP18/MP20) / CHARGUER (MP18/MP20) / AULFLADERÄT (MP18/MP20) / CARGADOR DE BATERIAS (MP18/MP20) (SHEET 14.A).....	31
ELECTRICAL DIAGRAM (MP16 STD & COLD STORE) / SCHEMA ELETTRICO (MP16 STD & COLD STORE) / SCHEMA ELECTRIQUE (MP16 STD & COLD STORE) / SCHALTPLAN (MP16 STD & COLD STORE) / ESQUEMA ELECTRICO (MP16 STD & COLD STORE) (SHEET 15.A).....	32
ELECTRICAL DIAGRAM (MP18 STD & COLD STORE /MP20 STD) / SCHEMA ELETTRICO (MP18 STD & COLD STORE /MP20 STD) / SCHEMA ELECTRIQUE (MP18 STD & COLD STORE/MP20 STD) / SCHALTPLAN (MP18 STD & COLD STORE/MP20 STD) / ESQUEMA ELECTRICO (MP18 STD & COLD STORE/MP20 STD) (SHEET 16.A).....	33
ELECTRICAL DIAGRAM (MP20 COLD STORE) / SCHEMA ELETTRICO (MP20 COLD STORE) / SCHEMA ELECTRIQUE (MP20 COLD STORE) / SCHALTPLAN (MP20 COLD STORE) / ESQUEMA ELECTRICO (MP20 COLD STORE) (SHEET 16/1.A).....	34
WIRING DIAGRAMS (MP16/MP18/MP20) / SCHEMI COLLEGAMENTI CAVI POTENZA (MP16/MP18/MP20) / DIAGRAMMA LIAISON CABLE ELECTRIQUE (MP16/MP18/MP20) / ELEKTRTSCHUANLAGEPLAN (MP16/MP18/MP20) / ESQUEMAS CONEXION CABLE POTENCIA (MP16/MP18/MP20) (SHEET 17.A-18.A-18/1.A-18/2.A)	35-38
SHEATH DIAGRAMS / SCHEMI COLLEGAMENTI GUAINA / DIAGRAMME LIAISON GAINES / MONTELANLAGEPLAN / ESQUEMAS CONEXION VAINA (SHEET 19.A - 20.A - 21.A - 21/1.A - 21/2.A).....	39-43
CONSOLE ADAPTER / ADATTATORE PER CONSOLE / ADAPTATEUR POUR CONSOLE / ADAPTER FÜR KONSOLLE / ADAPTADOR POR CONSOLA (SHEET 22.A)	44
CONNECTORS, CONTACTS, TOOLS / CONTATTI, CONNETTORI, UTENSILI / CONNECTEURS, CONTACTS, OUTILS / KONNEKTORS, KONTAKTS, WERKZEUG / CONTACTO, CONECTOR, UTENSILIO (SHEET 23.A)	46-47
HYDRAULIC DIAGRAM / SCHEMA IDRAULICO / SCHEMA HYDRAULIQUE / HYDRAULIKPLAN / ESQUEMA HIDRAULICO (SHEET24.A).....	48
ELECTRIC HORN / CLACKSON MAGGIORATO / KLAXON MAJORE / VERSTAERKTE HUPE/ AVISADOR ACUSTICO AUMENTADO (SHEET 25.A).....	49
LED INDICATOR HARNESS / INDICATORE LED CARICA BATTERIA / INDICATEUR LED DE CHARGE BATTERIE / LED-ANZEIGER FUER BATTERIELADUNG / INDICADOR LED CARGA BATERIA (SHEET 26.A).....	50
NUMERICAL INDEX / INDICE NUMERICO / INDEX GENERAL / ALGEMEINER INDEX / INDICE GENERAL.....	52-53

COVERS
CARTER
COUVERCLE
DECKEL
TAPAS

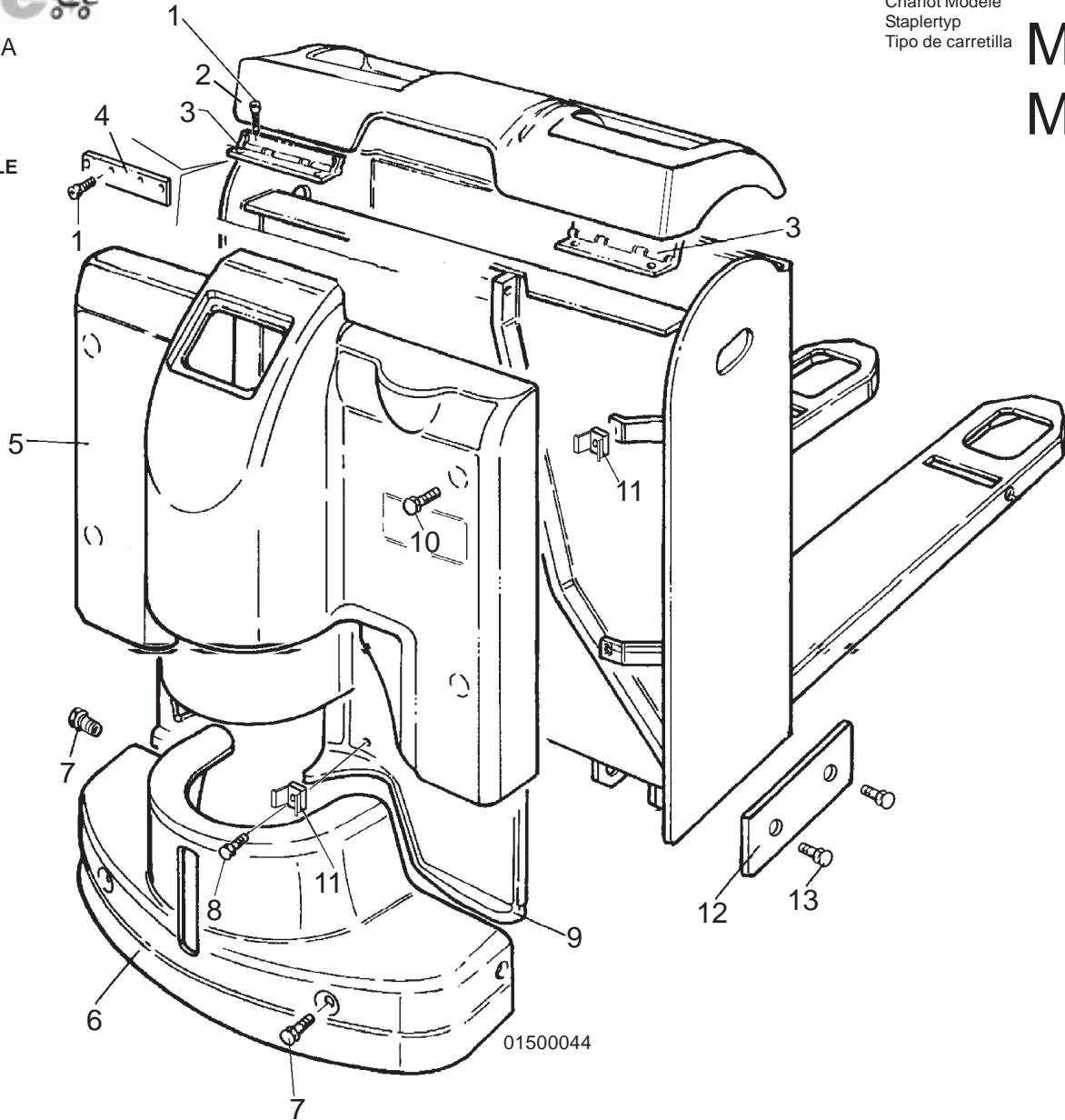

REF	PART N°	Qt.	DESCRIPTION	DESCRIZIONE	DESIGNATION	BENENNUNG	DENOMINACIONES
1	580013990	20	Screw	Vite	Vis	Schraube	Tornillo
2	580021944	1	Battery cover	Coperchio batteria	Couv ercle	Deckel	Tapa
2	580041285	1	Battery cover (Steel)	Coperchio batteria (acciaio)	Couv ercle	Deckel	Tapa
3	272337900	2	Hinge	Cerniera	Charniere	Scharnier	Charnela
4	272338200	2	Plate	Piastrino	Plaque	Platte	Placa
5	524160078	1	Cover (MP16)	Carter	Couv ercle	Deckel	Tapa
5	524160020	1	Cover (MP18-MP20)	Carter	Couv ercle	Deckel	Tapa
6	524160021	1	Cover (MP16)	Carter inferiore	Couv ercle	Deckel	Tapa
6	524167780	1	Cover (MP16) Opt.	Carter inferiore Opt.	Couv ercle	Deckel	Tapa Opc.
6	524167780	1	Cover (MP18-MP20)	Carter inferiore	Couv ercle	Deckel	Tapa
7	900014291	4	Screw	Vite	Vis	Schraube	Tornillo
8	580023068	2	Screw	Vite	Vis	Schraube	Tornillo
9	580033475	1	Cover	Carter interno	Couv ercle	Deckel	Tapa
10	900014292	4	Screw	Vite	Vis	Schraube	Tornillo
11	580015667	6	Locking nut	Dado in gabbia	Ecrou	Mutter	Tuerca
12	580041287	2	Guard	Protezione	Protection	Shutz	Defensa
13	580006788	4	Screw	Vite	Vis	Schraube	Tornillo

Da matr. / Du matr. / Ab. seriennummer
From serial N° / Desde la matr.:

Fino a matr. / Jusqu' matr. / Bis zur serien-Nr.
Until serial N° / Hasta la matr.:

Ad esclusione di / À l'exclusion de
Mit ausnahme von / With the exception of / Excepto:

Compreso / Avec / Einschließlich
Including / Con:

C841X01501A

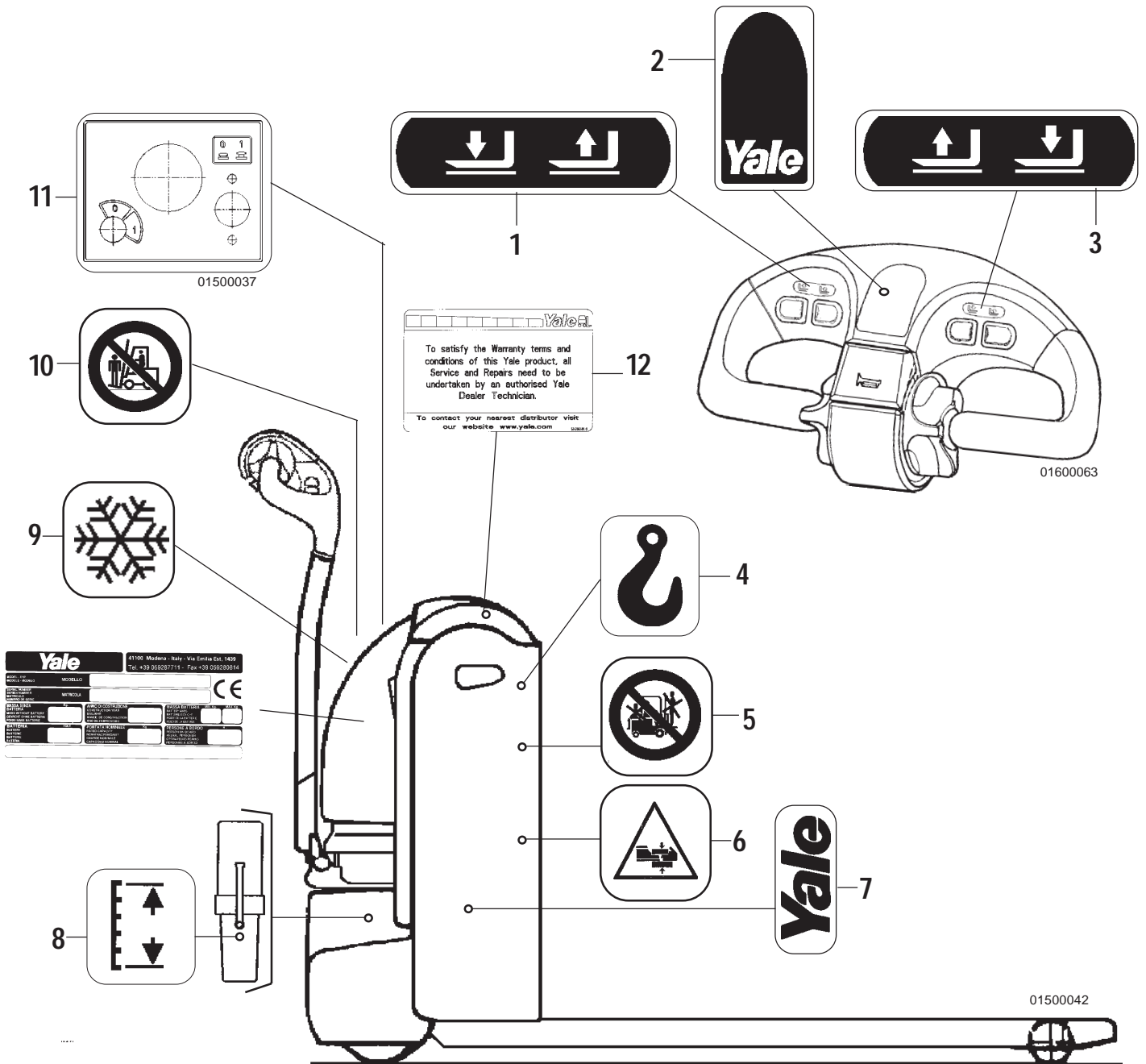

Da matr. / Du matr. / Ab. seriennummer From serial N° / Desde la matr.:	Fino a matr. / Jusqu' matr. / Bis zur serien-Nr. Until serial N° / Hasta la matr.:	Ad esclusione di / À l'exclusion de Mit ausnahme von / With the exception of / Excepto:	Compreso / Avec / Einschließlich Including / Con:

Thank you so much for reading.
Please click the “Buy Now!”
button below to download the
complete manual.



After you pay.

You can download the most
perfect and complete manual in
the world immediately.

Our support email:

ebooklibonline@outlook.com