

ERC20-30AGF

(E108)

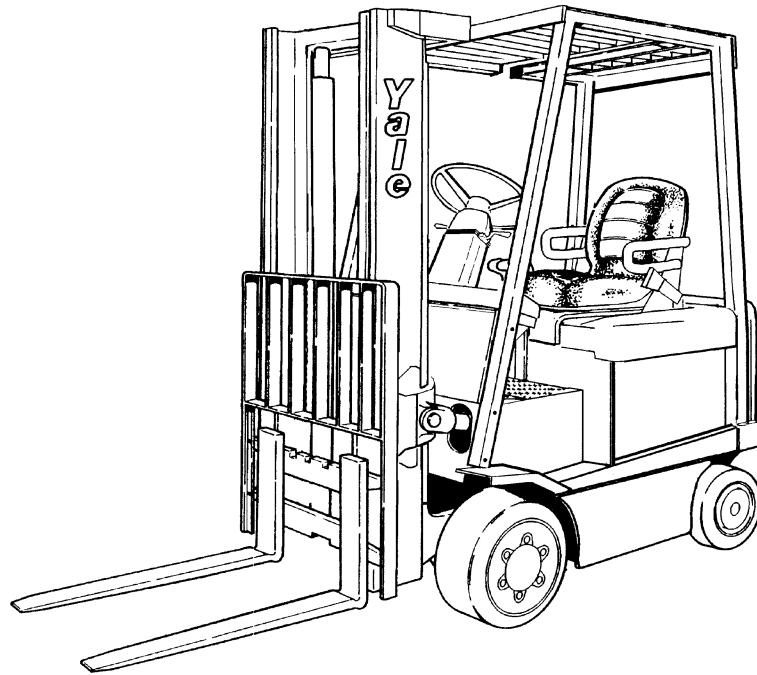

YP990017

1	GENERAL TRUCK	
2	ELECTRICAL SYSTEM	
3	DRIVE UNIT	
4	STEERING SYSTEM	
5	BRAKE SYSTEM	
6	HYDRAULIC SYSTEM	
7	MAST-TWO STAGE LIMITED FREE-LIFT	
8	MAST-THREE STAGE FULL FREE-LIFT	
9	MAST-TWO STAGE FULL FREE-LIFT	
10	FORKS, LOAD BACKREST, AND MAST INSTALLATION	
11	OPTIONS	
12	NUMERICAL INDEX	

**SECTION 1
GENERAL TRUCK**

DESCRIPTION	PAGE
ACCELERATOR PEDAL.....	1.12
COUNTERWEIGHT	1.20
COVERS	
D/B 10/1999⇒	1.36
⇒D/B 10/1999	1.34
FOOT DIRECTIONAL CONTROL PEDAL	
S/N E108A-02264W⇒	1.14
FRAME	
D/B 10/1999⇒	1.42
⇒D/B 11/1997	1.38
D/B 11/1997⇔D/B 10/1999	1.40
FULL SUSPENSION SEAT	
SHEET 1 OF 2	
D/B 12/2000⇒	1.8
SHEET 2 OF 2	
D/B 12/2000⇒	1.10
HOOD.....	1.28
LABELS.....	1.17
LATCH KIT	
OPTIONAL.....	1.32
LIFT TRUCK.....	1.2
NON-SUSPENSION SEAT	1.4
OVERHEAD GUARD	
⇒D/B 08/1996	1.22
D/B 08/1996⇔S/N E108A-02008U	1.24
S/N E108A-02009U⇒	1.26
SEMI-SUSPENSION SEAT	1.6

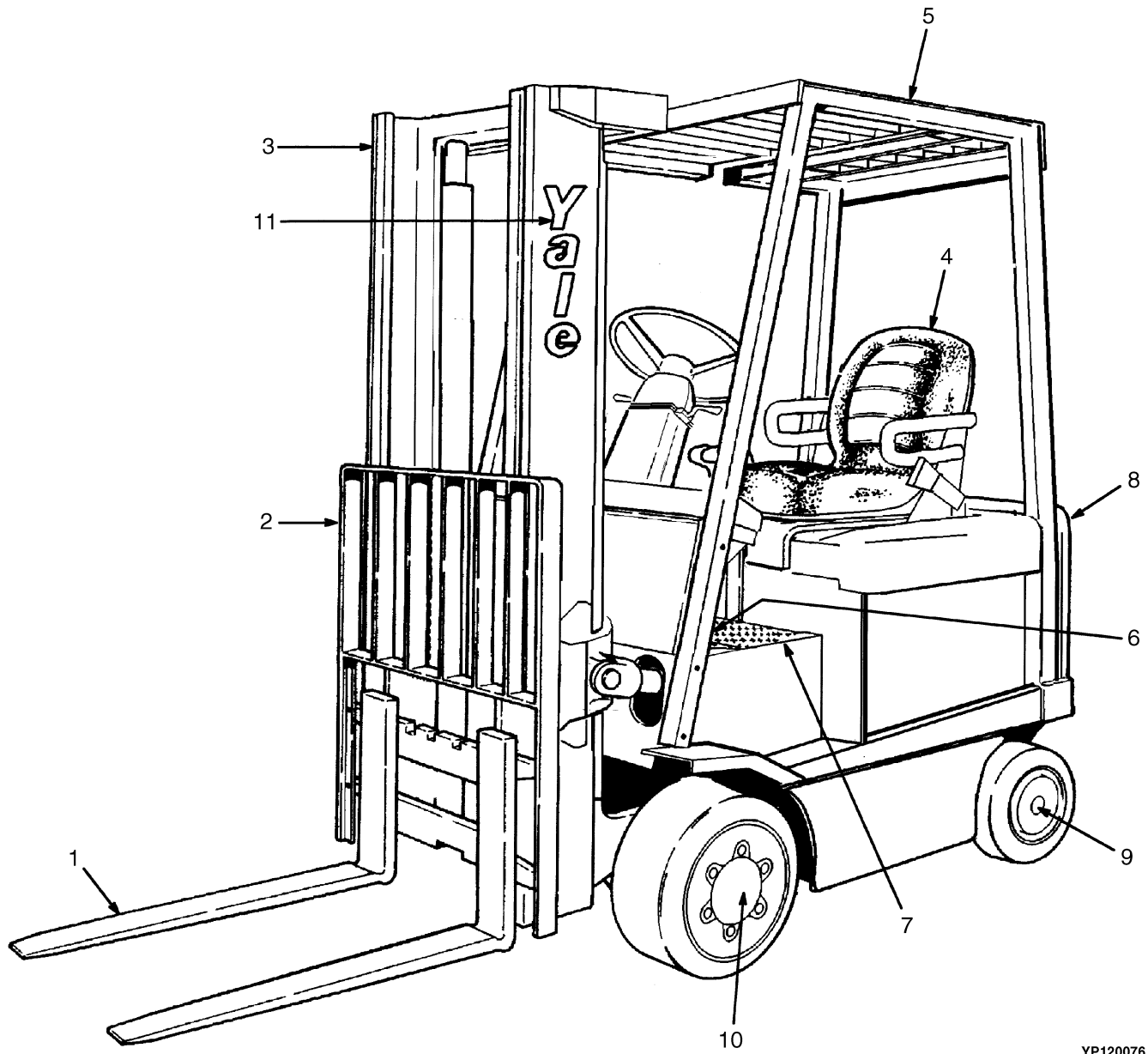

YP120076

ITEM	PART NO.	DESCRIPTION	QTY
1	Fork (☞ Page 10.8, ☞ Page 10.10)	2
2	Load Backrest Extension (☞ Page 10.2)	1
3	Mast-Two Stage Limited Free-Lift (☞ Page 7.2)	1
3	Mast-Two Stage Full Free-Lift (☞ Page 9.2)	1
3	Three Stage Full Free-Lift (☞ Page 8.2)	1
4	Seat (☞ Page 1.4)	1
5	Overhead Guard (☞ Page 1.22, ☞ Page 1.24, ☞ Page 1.26)	1
6	Accelerator Pedal (☞ Page 1.8)	1
7	Cowl and Floor Plates (☞ Page 1.32, ☞ Page 1.36)	1
8	Counterweight (☞ Page 1.20)	1
9	Trail Axle (☞ Page 4.2)	1
10	Drive Axle (☞ Page 3.2)	1
11	Label (☞ Page 1.12)	AR

NON-SUSPENSION SEAT

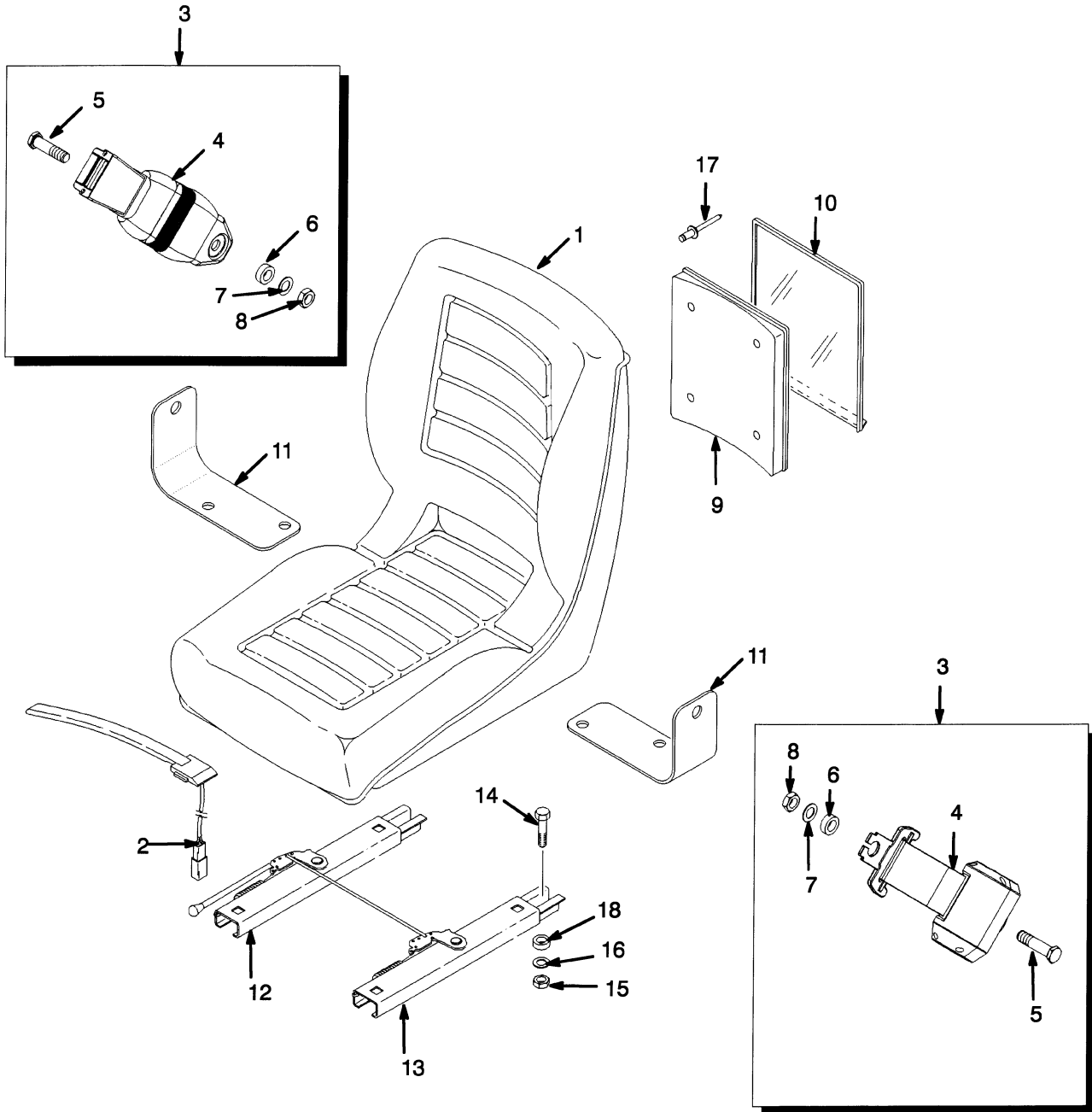

YP120077

ITEM	PART NO.	DESCRIPTION	QTY
	580008424	Non-Suspension Seat.....	1
1	504232248	Seat.....	1
2	504305734	Switch Assembly	1
3	580010327	Seat Belt Kit	1
4	Seat Belt	1
5	Screw	2
6	Washer.....	2
7	Washer.....	2
8	Nut	2
9	519996801	Base	1
10	519996803	Cover.....	1
11	580014487	Bracket	2
12	580014485	Seat Rail.....	1
13	580014486	Seat Rail.....	1
14	a 449001014	Capscrew.....	4
14	b 062143700	Capscrew.....	4
15	504238298	Nut.....	4
16	023604600	Washer	4
17	Rivet	4
18	a 520052862	Spacer	4
18	b 580022641	Spacer	4
18	520044851	Spacer (Optional)	4

FOOTNOTES:

a ⇒ S/N PENDING PER ECN 92036-09

b S/N PENDING PER ECN 92036-09 ⇒

SEMI-SUSPENSION SEAT

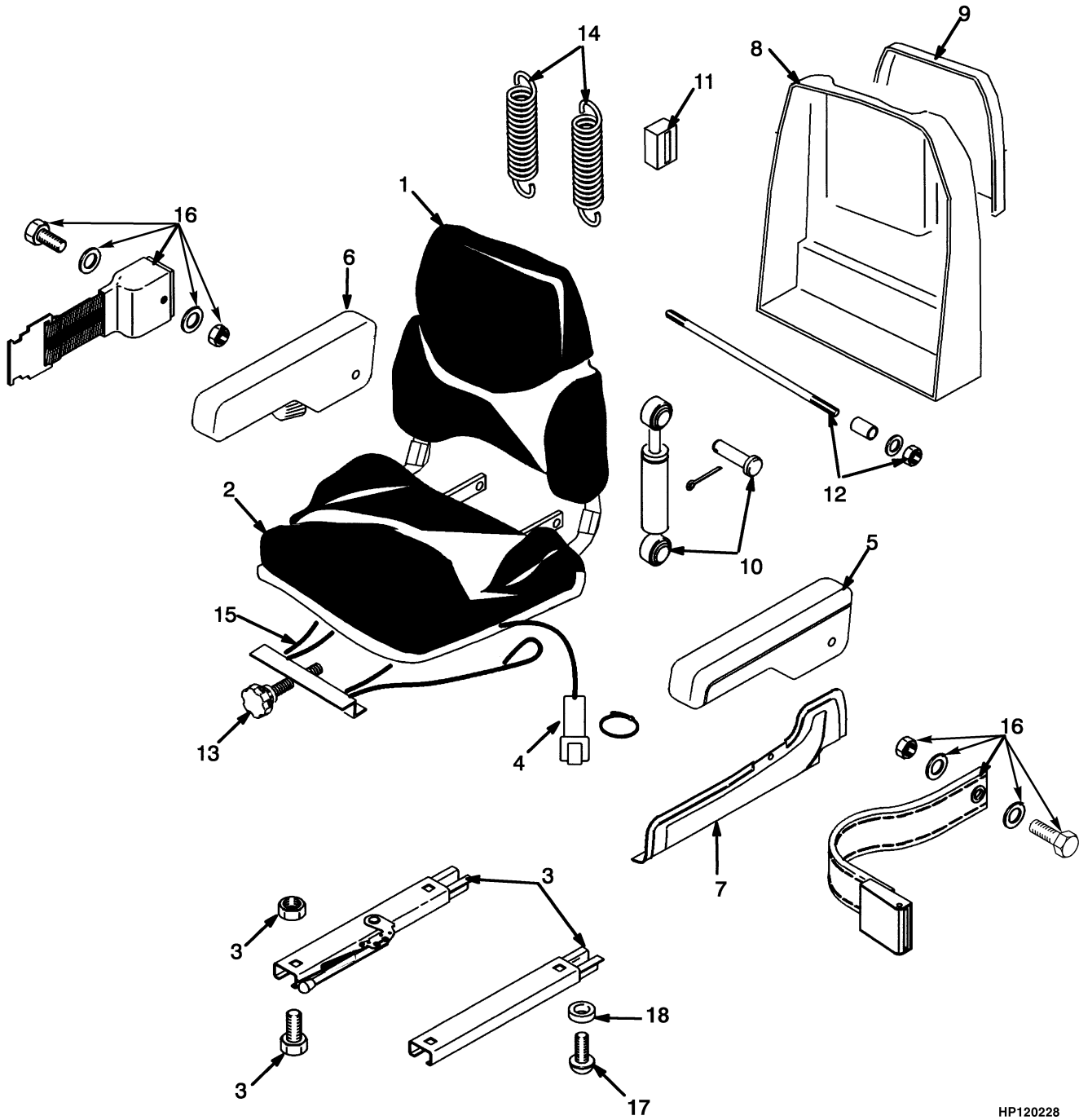

HP120228



SEMI-SUSPENSION SEAT

KEY:

A: Vinyl

B: Fabric

ITEM	PART NO.	DESCRIPTION	QTY	
			A	B
	258982303	Semi-Suspension Seat	1	..
	258982304	Semi-Suspension Seat	1
1	580002283	Back Cushion	1	..
1	524139404	Back Cushion	1
1	504289704	Back Cushion (Optional)	1	..
1	504289706	Back Cushion (Optional)	1
2	580002282	Seat Cushion.....	1	..
2	524139405	Seat Cushion.....	..	1
2	504289705	Seat Cushion (Optional).....	1	..
2	504289707	Seat Cushion (Optional).....	..	1
3	580010586	Seat Rail Kit	1	1
4	518793606	Switch Assembly	1	1
5	580010467	Armrest (LH).....	1	1
6	580010468	Armrest (RH).....	1	1
7	580008948	Cover (LH).....	1	1
7	580008947	Cover (RH)	1	1
8	580010679	Cover (Back)	1	1
9	580010469	Holder (Operator Manual)	1	1
10	520041836	Shock Absorber Kit	1	1
11	520041870	Block	1	1
12	520041896	Shaft and Bearing Kit	1	1
13	520041829	Knob Kit.....	1	1
14	520041644	Suspension Spring Kit.....	1	1
15	520041883	Suspension Cable Kit.....	1	1
16	580010327	Seat Belt Kit	1	1
17	530018801	Capscrew.....	4	4
18	520052862	Spacer	4	4
18	520044851	Spacer (Optional)	4	4

FULL SUSPENSION SEAT
(SHEET 1 OF 2)
(D/B 12/2000⇒)

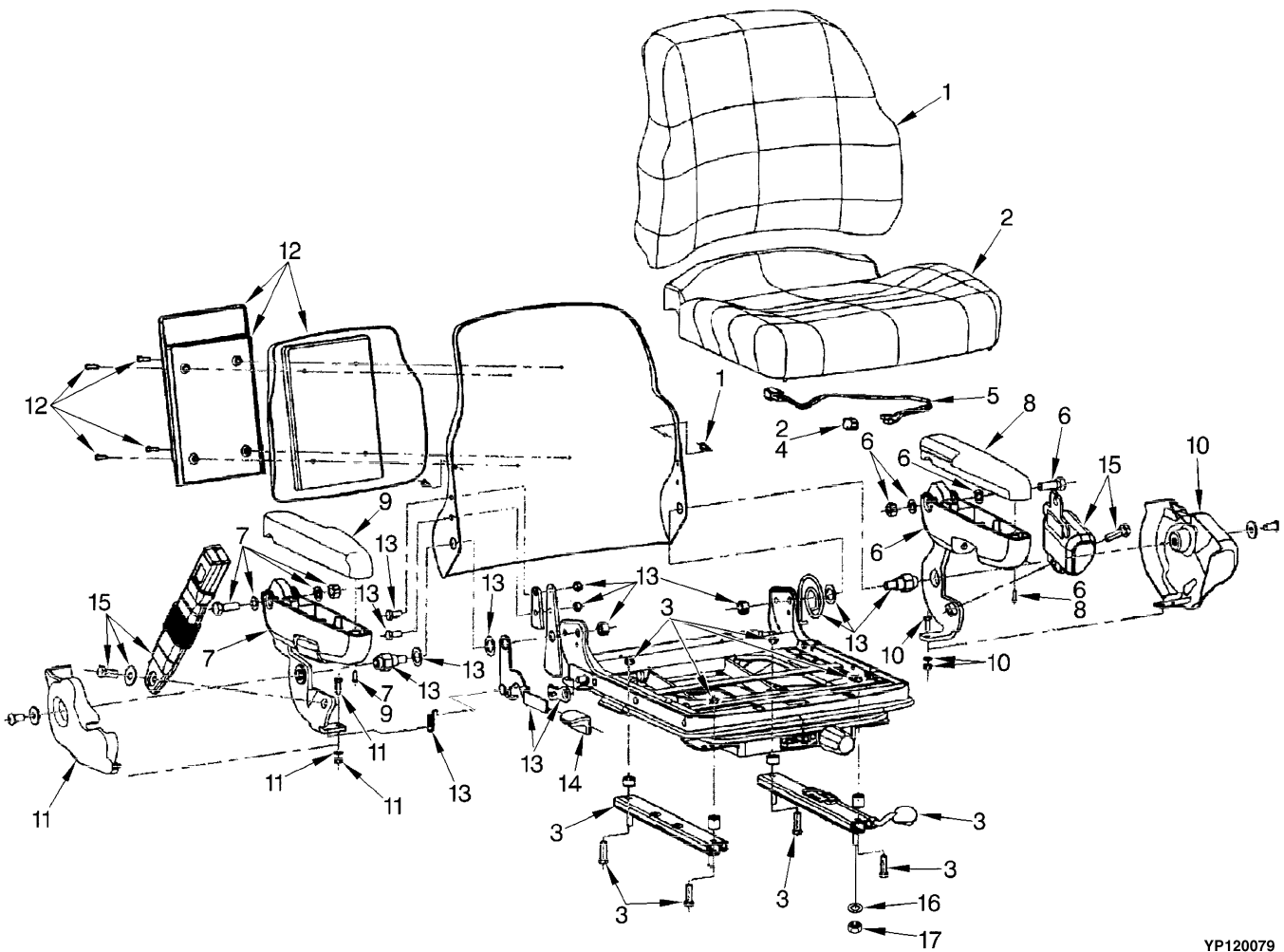

YP120079



**FULL SUSPENSION SEAT
(SHEET 1 OF 2)
(D/B 12/2000⇒)**

ITEM	PART NO.	DESCRIPTION	QTY
	524139223	Full Suspension Seat.....	1
	524139224	Full Suspension Seat (Fabric)	1
1	524139579	Back Cushion	1
1	524139580	Back Cushion (Fabric).....	1
2	524139581	Seat Cushion (Fabric)	1
2	580013429	Seat Cushion (Vinyl)	1
3	580013409	Slider Kit.....	1
4	580013410	Switch (Seat).....	1
5	580013411	Wire Harness	1
6	580013412	Armrest (LH) (LH).....	1
7	580013413	Armrest (RH) (RH)	1
8	580013414	Cap (LH).....	1
9	580013415	Cap (RH)	1
10	580013416	Cover (LH).....	1
11	580013417	Cover (RH)	1
12	580013418	Holder Kit	1
13	580013426	Recliner Kit.....	1
14	580013427	Recliner Knob.....	1
15	580013428	Seat Belt Kit	1
16	023604600	Washer	4
17	504238298	Nut.....	4

FULL SUSPENSION SEAT
(SHEET 2 OF 2)
(D/B 12/2000⇒)

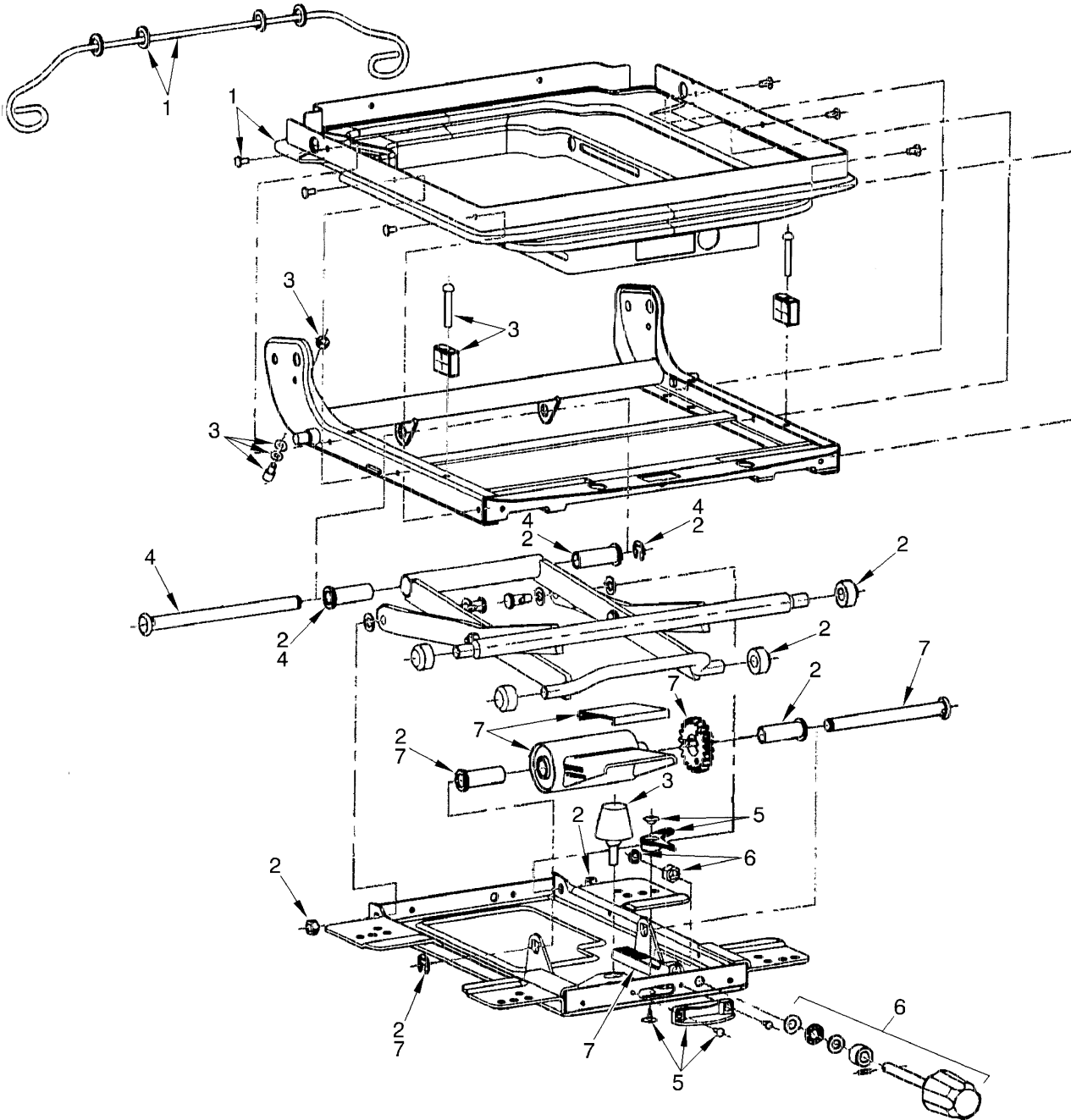

YP120080



**FULL SUSPENSION SEAT
(SHEET 2 OF 2)
(D/B 12/2000⇒)**

ITEM	PART NO.	DESCRIPTION	QTY
	524139223	Full Suspension Seat.....	1
	524139224	Full Suspension Seat (Fabric)	1
1	580013419	Boot Kit.....	1
2	580013420	Roller and Bearing Kit	1
3	580013421	Bumper and Stop Kit.....	1
4	580013422	Bearing Shaft Kit	1
5	580013423	Weight Adjuster Indicator Kit.....	1
6	580013424	Knob Kit.....	1
7	580013425	Suspension Spring Kit.....	1

ACCELERATOR PEDAL

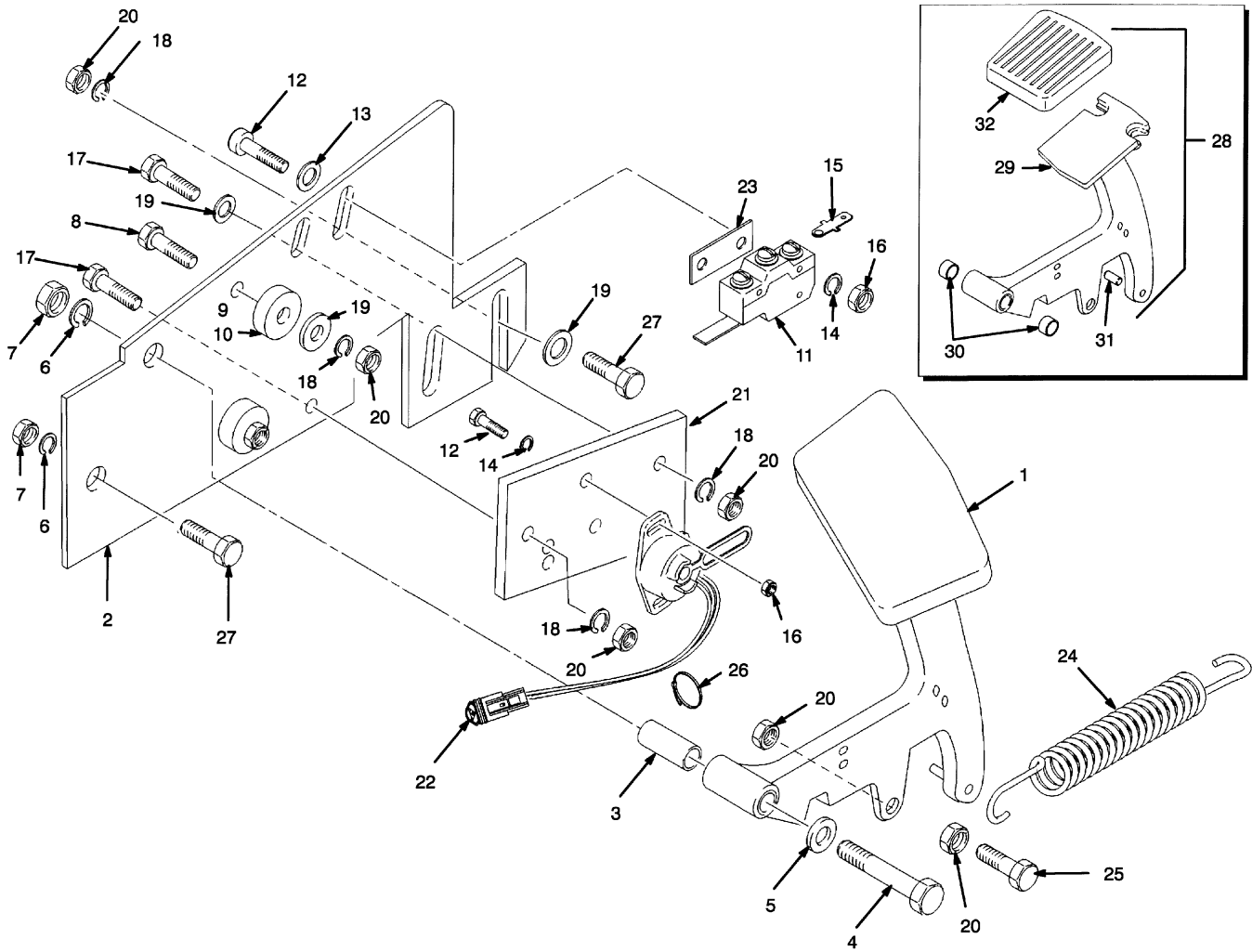

YP120081

ITEM	PART NO.	DESCRIPTION	QTY
1	Accelerator Pedal (Foot Directional Control Pedal) (☞ Page 1.14)	1
2	505966534	Bracket	1
3	505977519	Tube.....	1
4	449001233	Capscrew.....	1
5	449021006	Washer	1
6	449022013	Lockwasher	1
7	449015044	Nut.....	1
8	449001134	Capscrew.....	2
9	505977537	Pedal Stop	2
10	501702904	Adhesive.....	AR
11	504228295	Switch.....	1
12	014862000	Screw.....	4
13	016103200	Washer	4
14	502137903	Lockwasher	4
15	504057758	Electrical Connector	1
16	014936000	Nut.....	4
17	900014292	Capscrew.....	2
18	449022016	Lockwasher	7
19	449021001	Washer	5
20	449015014	Nut.....	8
21	505966556	Plate	1
22	505966574	Throttle Position Sensor	1
23	580010427	Insulator.....	1
24	505974576	Spring.....	1
25	449001052	Capscrew.....	1
26	312850042	Strap Clamp.....	1
27	449001014	Capscrew.....	2
28	505974543	Accelerator Pedal (Forward/Reverse).....	1
29	505974506	Pedal (Forward/Reverse).....	1
30	504228276	Bushing (Forward/Reverse).....	2
31	505974595	Pin (Forward/Reverse)	1
32	504228259	Pad (Forward/Reverse)	1

FOOT DIRECTIONAL CONTROL PEDAL (S/N E108A-02264W⇒)

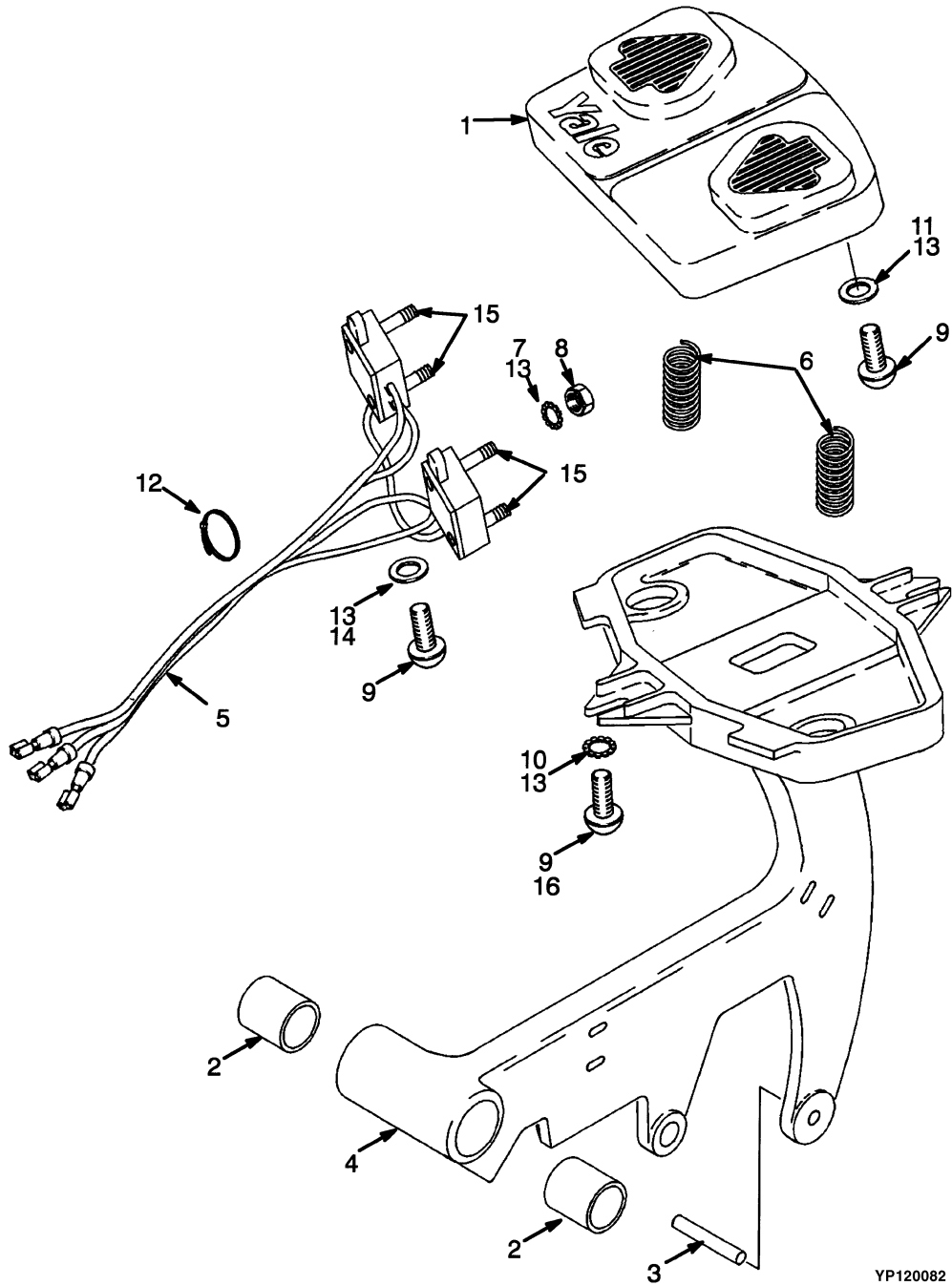

YP120082



FOOT DIRECTIONAL CONTROL PEDAL
(S/N E108A-02264W⇒)

ITEM	PART NO.	DESCRIPTION	QTY
	524137528	Foot Directional Control Pedal	1
1	524137230	Pad	1
2	504228276	Bushing	2
3	505974595	Pin	1
4	580010728	Bracket	1
5	a 580010428	Pedal	1
5	b 580014196	Switch Assembly	1
6	580010432	Spring	2
7	500552902	Lockwasher	4
8	032643500	Nut	4
9	a 502634904	Screw	6
10	065619300	Lockwasher	2
11	580010433	Washer	2
12	312850042	Strap Clamp	3
13	501702901	Sealant	AR
14	a 580010434	Washer	2
15	504225201	Capscrew	4
16	b 502634904	Screw	4

FOOTNOTES:

a ⇒ S/N E108A-2388X

b S/N E108A-2389X ⇒

LABELS

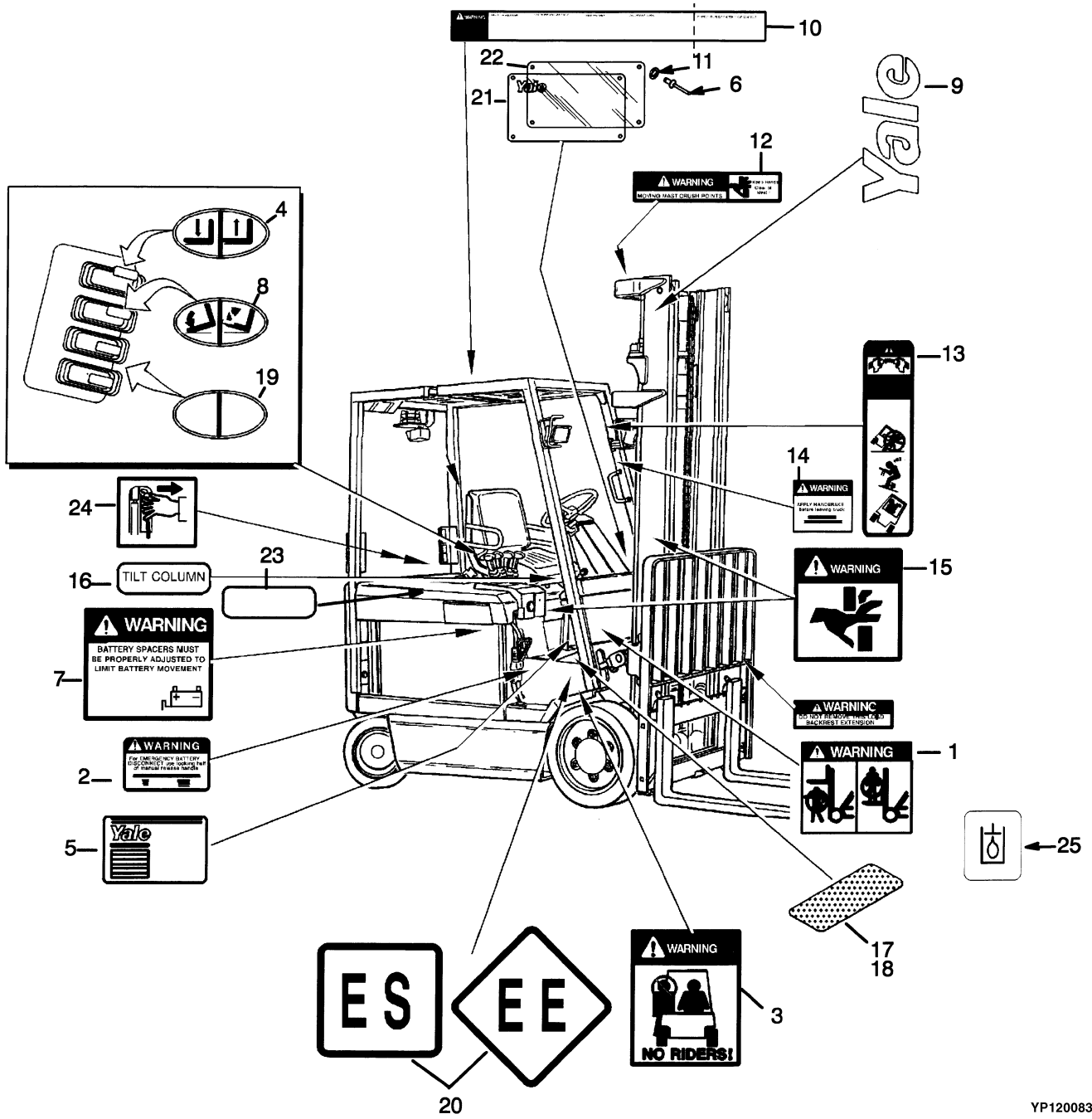

YP120083

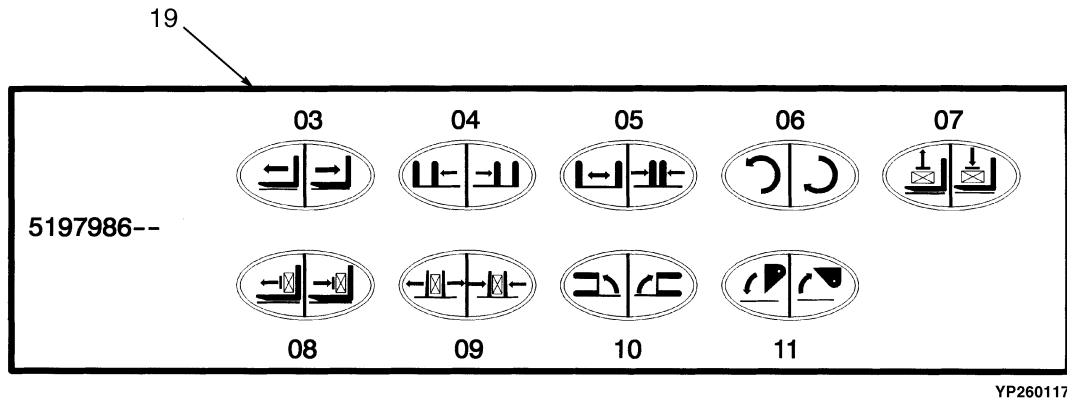

ITEM	PART NO.	DESCRIPTION	QTY
1	505972545	Label (Mast Warning)	2
2	504238227	Label (Battery Disconnect)	1
3	505972566	Label (No Riders)	2
4	519798601	Label (Hoist Handle).....	1
5	505890500	Label (Patents and Trademarks)	1
6	520045143	Rivet	4
7	518797644	Label (Battery Spacer)	1
8	519798602	Label (Tilt Handle)	1
9	912331302	Label (Yale).....	2
9	258984900	Decal (Yale) (Counterweight).....	1
10	504229237	Label (Operator Warning).....	1
11	518803661	Washer	4
12	504238219	Label (Mast Warning)	1
13	505973524	Label (Operator Restraint).....	2
14	c 518806691	Label (Park Brake Warning)	1
14	ab 518807633	Label (Park Brake Warning)	1
14	ad 519432675	Label (Parking Brake Warning).....	1
15	d 505974557	Label (Pinch Point)	3
15	b 505974557	Label (Pinch Point)	4
16	504955200	Label (Tilt Column)	1
17	f 504241582	Floormat (Rear)	1
17	504244764	Slip Resistant Tread (Rear)	1
17	g 504275794	Floormat (Forward).....	1
17	504275796	Slip Resistant Tread (Forward)	1
17	f 524136163	Floormat (Rear)	1
17	g 524136166	Floormat (Forward).....	1
18	504265776	Slip Resistant Tread (LH).....	1
18	504265777	Slip Resistant Tread (RH).....	1
18	504265778	Floormat (LH)	1
18	504265779	Floormat (RH).....	1
19	519798603	Label (Auxiliary Function - Reach)	1
19	519798610	Label (Auxiliary Function - Swing).....	1

LABELS

ITEM	PART NO.	DESCRIPTION	QTY
19	519798605	Label (Auxiliary Function - Fork Spreader).....	1
19	519798607	Label (Auxiliary Function - Stabilizer).....	1
19	519798611	Label (Auxiliary Function - Scoop).....	1
19	519798608	Label (Auxiliary Function - Push/Pull).....	1
19	519798609	Label (Auxiliary Function - Clamp).....	1
19	519798606	Label (Auxiliary Function - Rotate).....	1
19	519798604	Label (Auxiliary Function - Side-Shift).....	1
20	507558300	Label ("EE" Construction).....	1
20	751435300	Label (Type ES).....	1
21	504266709	Capacity Plate.....	1
22	504266716	Cover.....	1
23	520041811	Label (Hood Latch).....	1
24	518808611	Label (Prop Rod).....	1
25	e 520045119	Label (Hydraulic Oil Fill).....	1

FOOTNOTES:

- a With Park Brake Alarm
- b With Seat Switch
- c Without Parking Brake Alarm
- d Without Seat Switch
- e S/N E108A-1672 ⇒
- f ⇒ D/B 02/1998
- g D/B 02/1998 ⇒



NOTES

COUNTERWEIGHT

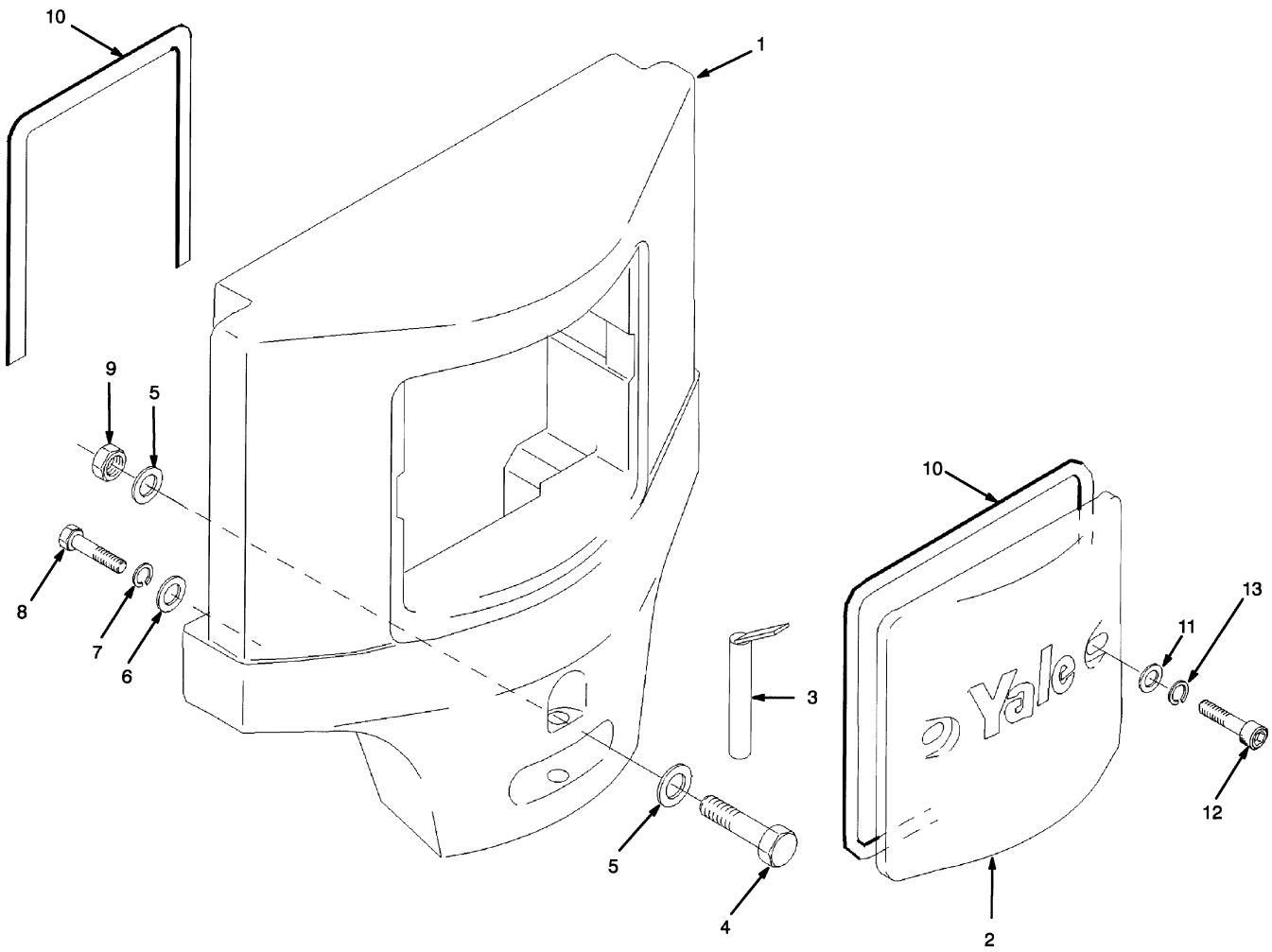

YP120084

ITEM	PART NO.	DESCRIPTION	QTY
1	ab 504241208	Counterweight (ERC 20-25 AGF)	1
1	b 504241223	Counterweight (ERC 30 AGF)	1
2	504241221	Cover	1
3	504224291	Tow Pin	1
4	449001351	Capscrew.....	2
5	504233271	Washer	4
6	061278400	Washer	2
7	015027000	Lockwasher	2
8	014717600	Capscrew.....	2
9	909882405	Locknut	2
10	504224270	Tape.....	AR
11	449021006	Washer	2
12	449002142	Capscrew.....	2
13	449022013	Lockwasher	2

FOOTNOTES:

- a** 1015 mm Battery Compartment
- b** 847 mm Battery Compartment

OVERHEAD GUARD
(⇒D/B 08/1996)

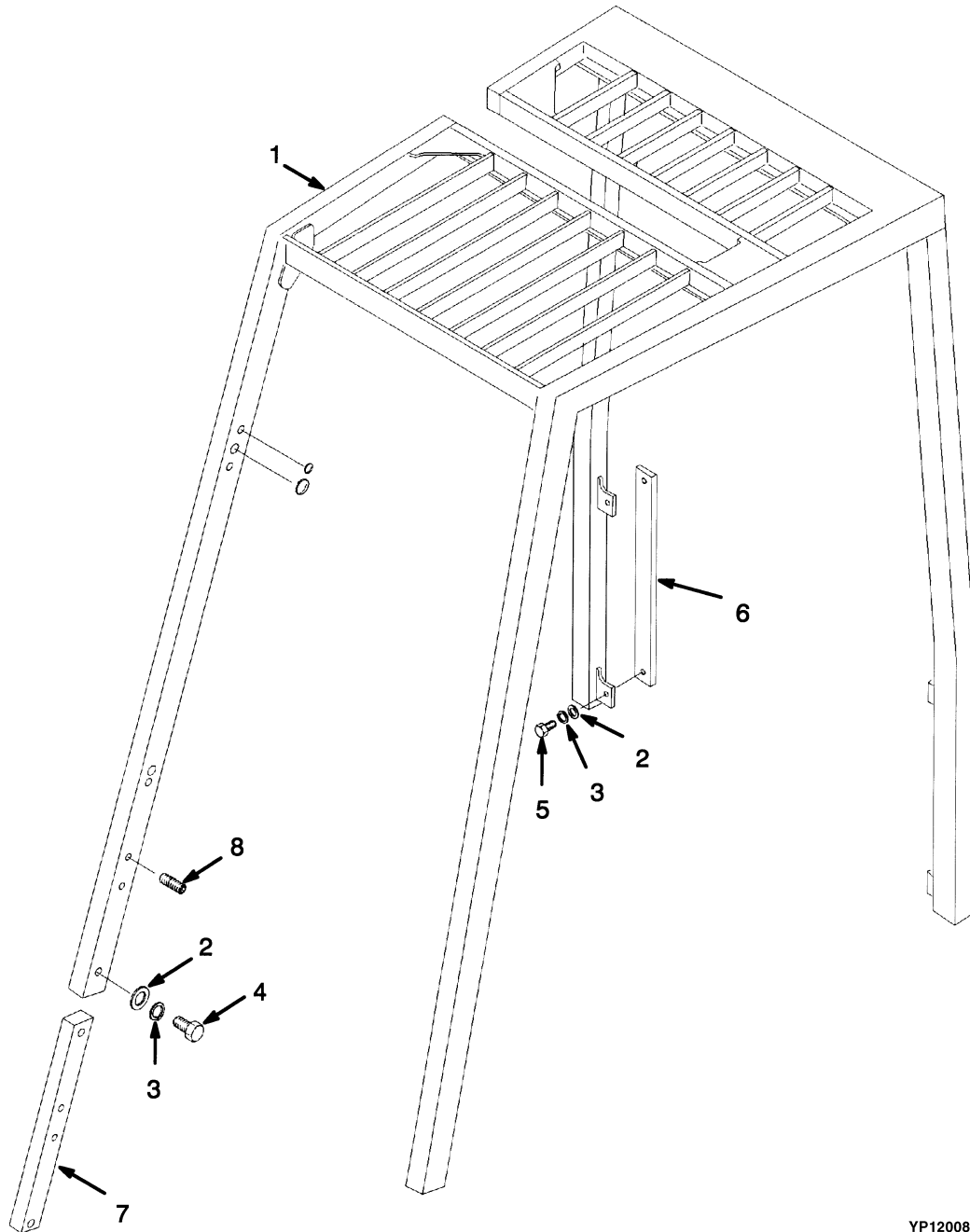

YP120085

Thank you so much for reading.
Please click the “Buy Now!”
button below to download the
complete manual.



After you pay.

You can download the most
perfect and complete manual in
the world immediately.

Our support email:

ebooklibonline@outlook.com