

Parts Manual
Elenco Ricambi
Manuel des Pièces de Rechange
Ersatzteilkatalog
Manual de Repuestos

CE

MS 10E

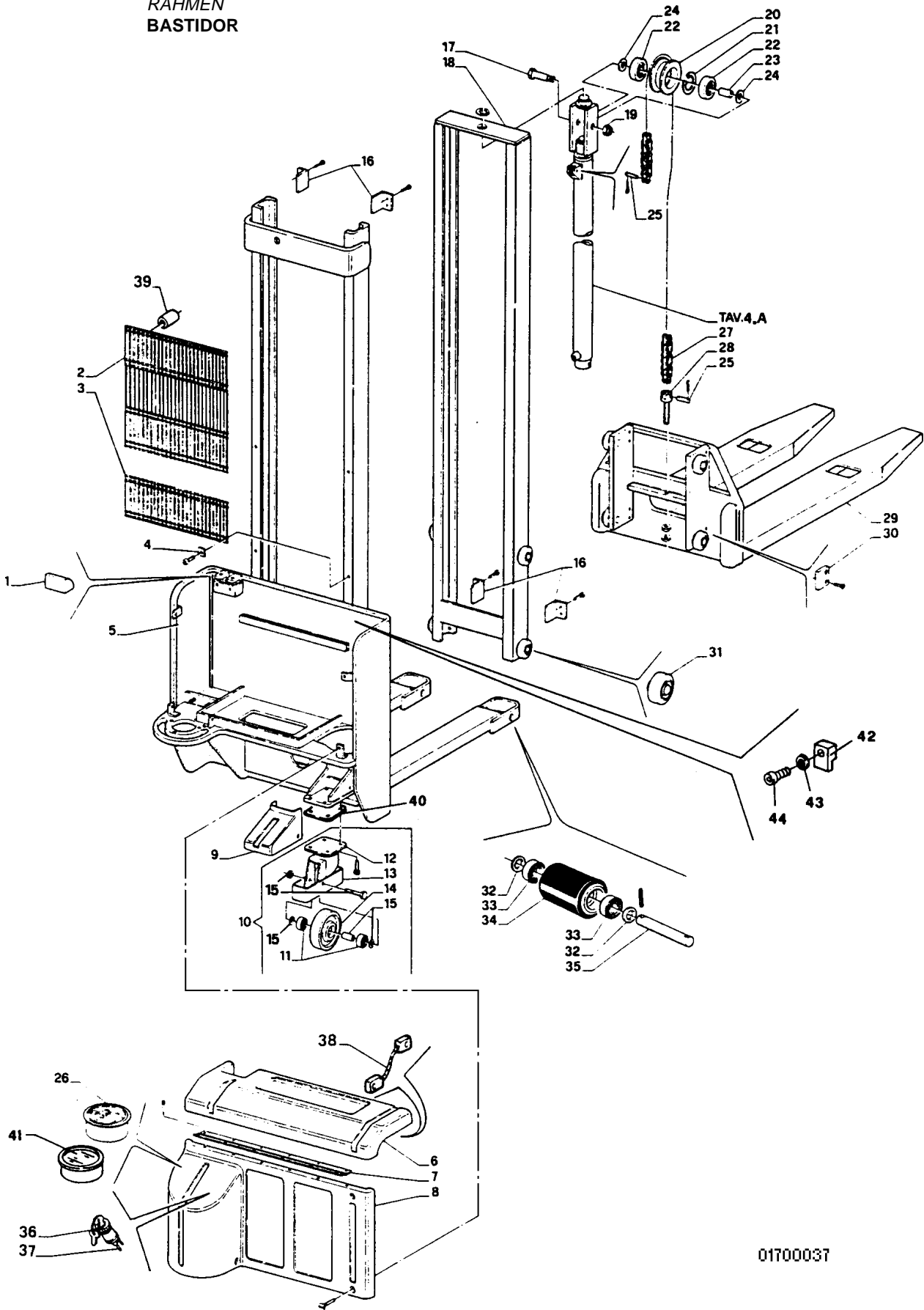



01700037

Da matr. / Du matr. / Ab. seriennummer
From serial N° / Desde la matr.:

Fino a matr. / Jusqu' matr. / Bis zur serien-Nr.
Until serial N° / Hasta la matr.:

Ad esclusione di / À l'exclusion de
Mit ausnahme von / With the exception of / Excepto:

Compreso / Avec / Einschließlich
Including / Con:

A845X01624V



SHEET 1.B

FRAME
TELAIO
CHASSIS
RAHMEN
BASTIDOR

Truck Model
 Carrello Tipo
 Chariot Modele
 Staplertyp
 Tipo de carretilla

MS 10 E

REF	PART N°	Qt.	DESCRIPTION	DESCRIZIONE	DESIGNATION	BENENNUNG	DENOMINACIONES
1	272052200	1	Cover	Coperchio	Couvercle	Deckel	Tapa
2	272116400	1	Guard (1 Stage/17-2 Stage/27)	Rete	Grillage	Drahnetz	Red
2	272116300	1	Guard (2 Stage/32)	Rete	Grillage	Drahnetz	Red
2	272115000	1	Guard (2 Stage/37)	Rete	Grillage	Drahnetz	Red
3	272115600	1	Guard (1 Stage/17)	Rete	Grillage	Drahnetz	Red
3	272115700	1	Guard (2 Stage/37)	Rete	Grillage	Drahnetz	Red
4	272018600	VM	Plate	Piastrina	Plaque	Plattchen	Placa
5	272192200	1	Frame (h 1700)	Telaio	Chassis	Rahmen	Bastidor
5	272192500	1	Frame (h 2700)	Telaio	Chassis	Rahmen	Bastidor
5	272193900	1	Frame (h 3200)	Telaio	Chassis	Rahmen	Bastidor
5	272192300	1	Frame (h 3700)	Telaio	Chassis	Rahmen	Bastidor
6	272116900	1	Top cover	Coperchio	Couvercle	Deckel	Tapa
7	272188400	1	Hinge	Cerniera	Charnière	Scharnier	Charnela
8	272151600	1	Cover	Carter	Carter	Gehäuse	Carter
9	272153000	1	Cover	Coperchio	Couvercle	Deckel	Tapa
10	272172600	1	Caster asm	Supporto girevole	Support	Traeger	Soporte
11	272002700	2	Bearing	Cuscinetto	Roulement	Lager	Rodamiento
12	272128900	1	Support	Supporto	Support	Traeger	Soporte
13	272088900	1	Guard	Protezione	Protection	Schutz	Defensa
14	272073200	1	Wheel	Ruota	Roue	Rad	Rueda
15	272098300	1	Axle group	Gruppo assale	Groupe essieu	Achsennguppe	Grupo eje
16	272024900	4	Bearing block (4mm)	Pattino	Patin	Schlitten	Patin
16	272024700	4	Bearing block (5 mm)	Pattino	Patin	Schlitten	Patin
16	272024500	4	Bearing block (6 mm)	Pattino	Patin	Schlitten	Patin
17	272094800	1	Shaft	Viteria	Vis	Schrauben	Tornillos
18	272183400	1	Inner upr. (2 Stage - 27)	Montant scorr.	Montant couliss	Schiebenhubger.	Montante corred.
18	272183100	1	Inner upr. (2 Stage - 32)	Mont. scorr.	Montant couliss	Schiebenhubger.	Montante corred.
18	272183200	1	Inner upr. (2 Stage - 37)	Mont. scorr.	Montant couliss	Schiebenhubger.	Montante corred.
19	272095900	1	Nut	Viteria	Vis	Schrauben	Tornillos
20	272089300	1	Sheave	Carrucola	Poulie	Scheibe	Polea
21	272022500	1	Retaining ring	Anello Seeger	Bague d'arret	Drahtsprengring	Anillo seguridad
22	272023400	2	Bearing	Cuscinetto	Roulement	Lager	Rodamiento
23	272063200	1	Tube	Tubo	Tuyau	Gummischlauch	Tubo
24	272006400	VM	Washer	Rondella	Rondelle	Scheibe	Arandela
25	272017600	2	Pin	Perno	Goujon	Bolzen	Pivote
26	272371600	1	Battery discharge meter	Voltmetro	Voltametre	Voltmeter	Voltmetro
27	272386000	1	Chain (h 1700)	Catena	Chaine	Kette	Cadena
27	272386100	1	Chain (h 2700)	Catena	Chaine	Kette	Cadena
27	272386200	1	Chain (h 3200)	Catena	Chaine	Kette	Cadena
27	272386300	1	Chain (h 3700)	Catena	Chaine	Kette	Cadena
28	272050100	1	Anchor	Perno	Goujon	Bolzen	Pivote
29	272149600	1	Fork carriage (1 Stage)	Forca (F1)	Fourche (F1)	Forke (F1)	Horca (F1)
29	272152000	1	Fork carriage (2 Stage)	Forca (F2)	Fourche (F2)	Forke (F2)	Horca (F2)

Da matr. / Du matr. / Ab. seriennummer
 From serial N° / Desde la matr.:

Fino a matr. / Jusqu' matr. / Bis zur serien-Nr.
 Until serial N° / Hasta la matr.:

Ad esclusione di / À l'exclusion de
 Mit ausnahme / With the exception of / Excepto:

Compreso / Avec / Einschließlich
 Including / Con:

A845X01624V

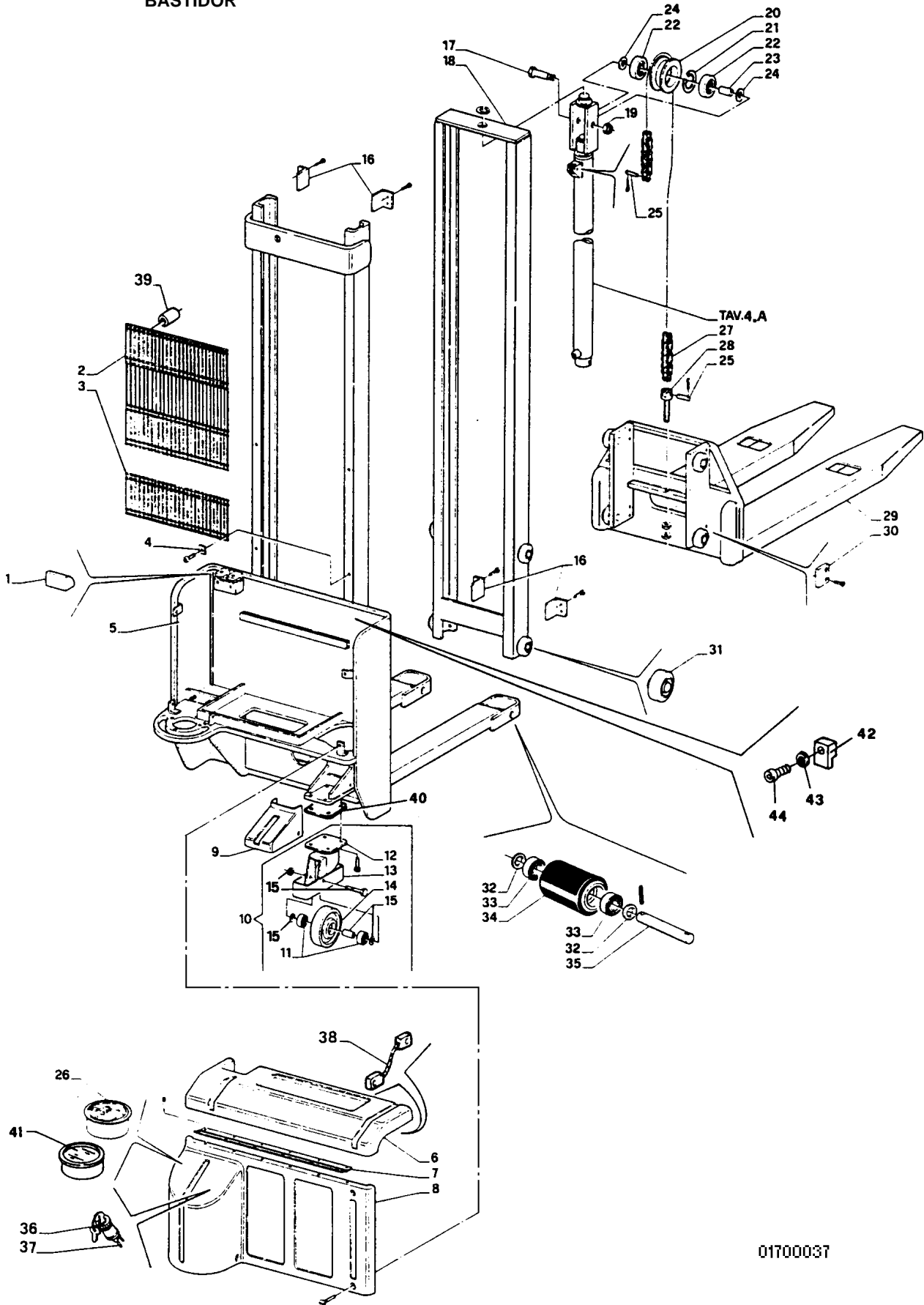

01700037

Da matr. / Du matr. / Ab. seriennummer
 From serial N° / Desde la matr.:

Fino a matr. / Jusqu' matr. / Bis zur serien-Nr.
 Until serial N° / Hasta la matr.:

Ad esclusione di / À l'exclusion de
 Mit ausnahme von / With the exception of / Excepto:

Compreso / Avec / Einschließlich
 Including / Con:

A845X01624V

REF	PART N°	Qt.	DESCRIPTION	DESCRIZIONE	DESIGNATION	BENENNUNG	DENOMINACIONES
30	272014200	4	Bearing block (4mm)	Pattino Sp. 4	Patin Sp. 4	Schlitten Sp. 4	Patin Sp. 4
30	272014400	4	Bearing block (5 mm)	Pattino Sp. 5	Patin Sp. 5	Schlitten Sp. 5	Patin Sp. 5
30	272014500	4	Bearing block (6 mm)	Pattino Sp. 6	Patin Sp. 6	Schlitten Sp. 6	Patin Sp. 6
31	272011000	8	Bearing (complete)	Cuscinetto compl.	Roulement	Lager Rodamiento	Rodamiento
32	272024600	4	Washer	Rondella piana	Rondelle	Scheibe	Arandela
33	272002700	4	Bearing	Cuscinetto	Roulement	Lager	Rodamiento
34	272030100	2	Roller	Rullo	Roller	Rolle	Rodillo
35	272023800	2	Pin	Perno	Gojon	Bolzen	Pivote
36	272029100	1	Key switch	Interruttore a chiave	Interrupteur	Schalter	Interruptor
37	272121600	VM	Cable	Cavo elettrico	Cable	Leitung	Cable
38	272099700	1	Cable	Cavo metallico	Cable	Leitung	Cable
39	272198000	8	Spacer(1 Stage/17)	Distanziale	Entretoise	Entfern	Separador
39	272197900	6	Spacer(2 Stage/37)	Distanziale	Entretoise	Entfern	Separador
40	272125400	VM	Flange	Flangia	Bride	Flansch	Brida
41	272013500	1	Hourmeter	Contaore	Compteur horaire	Betriebsstundenzaeh.	Cuentaoras
42	272212800	2	Battery stop	Fermo batteria	Fixation batterie	Batteriestillstand	Sujetador batteria
43	272211100	2	Washer	Rondella	Rondelle	Scheibe	Arandela
44	272211200	2	Screw	Vite	Vis	Schrauben	Tornillos

Da matr. / Du matr. / Ab. seriennummer
From serial N° / Desde la matr.:

Fino a matr. / Jusqu' matr. / Bis zur serien-Nr.
Until serial N° / Hasta la matr.:

Ad esclusione di / À l'exclusion de
Mit ausnahme von / With the exception of / Excepto:

Compreso / Avec / Einschließlich
Including / Con:

A845X01624V

DRAWBAR CONTROL BOX
TIMONE SCATOLA COMANDI
BARRE BOITE DE COMMANDE
DEICHSEL STEUERUNGSBUCHSE
DIRECCION DE MANDOS

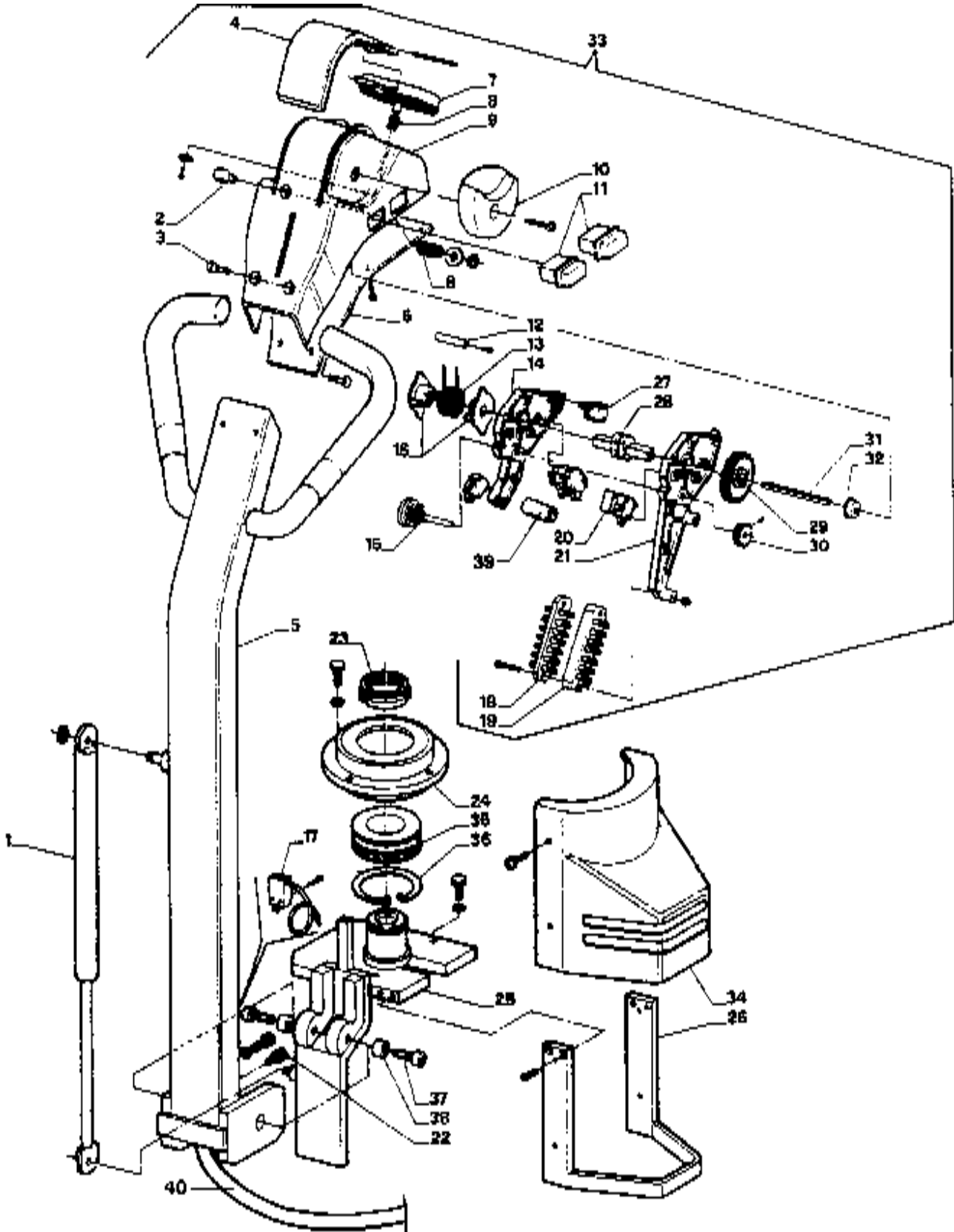

Da matr. / Du matr. / Ab. seriennummer
From serial N° / Desde la matr.:

Fino a matr. / Jusqu' matr. / Bis zur serien-Nr.
Until serial N° / Hasta la matr.:

Ad esclusione di / À l'exclusion de
Mit ausnahme von / With the exception of / Excepto:

Compreso / Avec / Einschließlich
Including / Con:

A845X1501T

Thank you so much for reading.
Please click the “Buy Now!”
button below to download the
complete manual.



After you pay.

You can download the most
perfect and complete manual in
the world immediately.

Our support email:

ebooklibonline@outlook.com