

**1350, 1360
and 1460
Mower-Conditioners**
(From Serial No. 341601)

**John Deere Arc-lès-Gray
OMCC41621 Issue L6**

European Edition
Printed in Germany
ANGLAIS

Contents

	Page		Page
Identification Views	00-1	Breaking-In Mower-Conditioner	30-2
Safety	05-1	Starting And Driving	30-3
Safety Decals	10-1	Operating The Linkage Drawbar Tongue	30-4
Preparing the Tractor		Operating The Swivel Hitch	30-5
Adjusting Tractor Drawbar	15-1	Front Safety Curtain	30-6
Installing Equal Hitch To Tractor Drawbar	15-1	Side Safety Curtains	30-7
Attaching and Detaching		Adjusting Cutting Height	30-8
Tractor Hydraulic Connections	20-1	Adjusting Platform Float	30-9
PTO Speed	20-2	Adjusting Conditioning Intensity (1350-1360)	30-10
Tractor Electrical Connection	20-2	Changing Rotor Speed (1350-1360)	30-11
Attaching Pin Drawbar Tongue To The Tractor	20-3	Adjusting Conditioning Intensity (1460 only)	30-12
Attaching Linkage Drawbar Tongue To The Tractor	20-4	Checking Conditioning Effect	30-12
Attaching Swivel Hitch To The Tractor	20-9	Adjusting Windrow Width	30-13
Adjusting Telescoping Hook-up	20-10	Adjusting Windrow Deflector	30-13
Connecting Telescoping Hook-up	20-11	Operating The Grouper	30-14
Tongue Positioner Rope	20-12	Adjusting Canvas Speed	30-16
Securing Jackstand	20-13	Raising/Lowering The Grouper	30-18
Detaching Telescoping Hook-Up	20-14	Grouper Lock Device	30-19
Securing Telescoping Hook-Up	20-14	Adjusting Canvas Frame Position	30-20
Securing Jackstand	20-15	Tire Inflation	30-20
Detaching Pin Drawbar Tongue	20-16	Attachments	
Detaching Linkage Drawbar Tongue And Swivel Hitch	20-16	Hydraulic Tongue Positioning	35-1
Transporting the Mower-Conditioner		Extended Hitch for Linkage Drawbar Tongue	35-1
Rope Control Positioner	25-1	Tongue Height Resume Chain	35-1
Hydraulic Tongue Positioning	25-3	Wide Rear Windrow Deflector	35-1
Tongue Positioning Lock Pin	25-5	Powered Windrow Deflectors	35-2
Securing Jackstand	25-6	Road Lighting	35-2
Transporting On The Road	25-6	Canvas Speed Remote Control	35-3
Transporting With Grouper	25-7	1000 rpm Rotor Speed	35-3
Operating the Mower-Conditioner		Equal Hitch	35-4
Pre-Operation Checklist	30-1	Safety Chain	35-4
		Lubrication and Maintenance	
		Observe Service Intervals	40-1
		As Required	40-5

Continued on next page

All information, illustrations and specifications in this manual are based on the latest information available at the time of publication. The right is reserved to make changes at any time without notice.

OMCC41621 L6-19-15FEB97

COPYRIGHT© 1996
DEERE & COMPANY
European Office Mannheim
All rights reserved
A John Deere ILLUSTRATION™ Manual
Previous Editions
Copyright 1994 Deere & Company

Contents

	Page		Page
Every 10 Hours	40-7	Removing And Servicing Knives	50-23
Every 100 Hours	40-12	Installing Knives	50-24
Draining/Refilling Main Drive Gear Case	40-13	Checking Knife Wear	50-25
Draining/Refilling Roller Drive Gear Case	40-14	Checking Knife Fitting Hole	50-26
Draining/Refilling Cutterbar	40-14	Checking Knife Hardware	50-26
Every 250 Hours	40-16	Checking Knife Bolt Wear	50-27
Draining/Refilling Swivel Hitch Gear Cases	40-16	Checking Knife Lock Nut Wear	50-28
Every 400 Hours	40-17	Replacing Rotor Tines	50-28
Every 6 Years	40-17	Adjusting Wheel Bearings	50-29
 Troubleshooting		 Storage	
Mower-Conditioner Operation	45-1	After The Season	55-1
Grouper Electrical System	45-4	Before The Season	55-2
Grouper Canvas Operation	45-5	 Specifications	
Grouper Canvas Alignment	45-6	1350 Mower-Conditioner	60-1
Grouper Canvas Drive	45-6	1360 Mower-Conditioner	60-2
Locking System For PTO Drive Shafts	45-7	1460 Mower-Conditioner	60-3
End Yokes	45-8	Grouper	60-4
Inboard Yokes	45-9	 Serial Numbers	
Profile Tubes	45-10	Serial Number Plates	65-1
PTO Drive Shaft Guards	45-11	Product Identification Number	65-1
 Service		Grouper Serial Number	65-1
Platform Cylinder Stops	50-2	 Index	
Bearing Locking Collars	50-2		
Adjusting Slip Clutch	50-3		
Adjusting Belt Tension	50-4		
Removing Drive Belt (1350-1360)	50-5		
Installing Drive Belt (1350-1360)	50-5		
Removing Drive Belt (1460 Only)	50-5		
Installing Drive Belt (1460 Only)	50-6		
Adjusting Roll Spacing (1460 Only)	50-7		
Adjusting Roll Synchronization (1460 Only)	50-8		
Adjusting Grouper Canvas Tension	50-9		
Adjusting Grouper Canvas Tracking	50-10		
Replacing Grouper Rubber Band And Canvas	50-11		
Removing Grouper Canvas Drive Roll	50-12		
Installing Grouper Canvas Drive Roll	50-13		
Adjusting Hydraulic Pump Drive Belt	50-14		
Replacing Hydraulic Pump Drive Belt	50-16		
Grouper Raising And Lowering Time	50-19		
Leveling Grouper Canvas Frame	50-20		
Removing Disks	50-21		
Synchronizing Disks	50-21		
Understanding Direction Of Knife Rotation	50-22		
Direction Of Disk Rotation	50-22		
Checking The Knives	50-23		

Identification Views



CC001311

CC001311 -UN-08FEB95

Version with linkage drawbar tongue

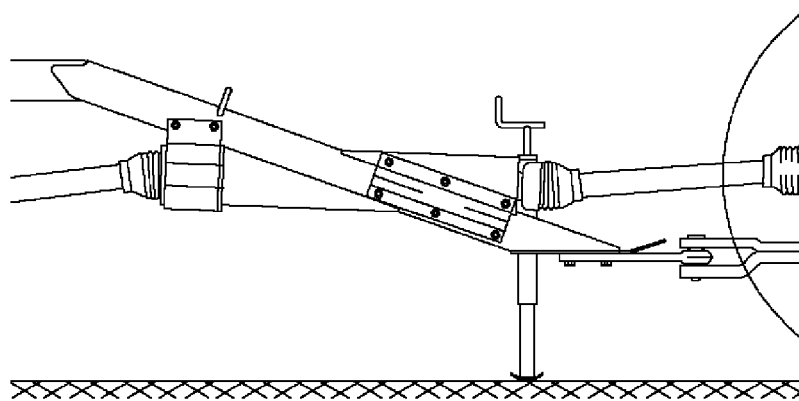

CC009794

CC009794 -UN-15JAN97

Version with pin drawbar tongue

CC,1350MC003619-19-21NOV96

Identification Views

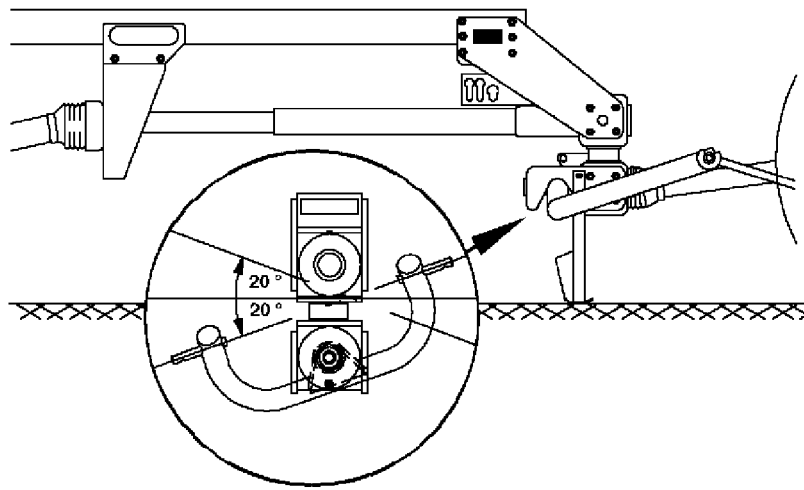

CC009796

Version with swivel hitch

CC009796 -UN-15.JAN97

CC,1350MC003709-19-16DEC96

Safety

RECOGNIZE SAFETY INFORMATION

This is the safety-alert symbol. When you see this symbol on your machine or in this manual, be alert to the potential for personal injury.

Follow recommended precautions and safe operating practices.

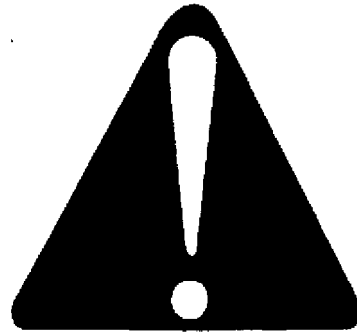

DX,ALERT -19-03MAR93

T81389 -UN-07DEC68

FOLLOW SAFETY INSTRUCTIONS

Carefully read all safety messages in this manual and on your machine safety signs. Keep safety signs in good condition. Replace missing or damaged safety signs. Be sure new equipment components and repair parts include the current safety signs. Replacement safety signs are available from your John Deere dealer.

Learn how to operate the machine and how to use controls properly. Do not let anyone operate without instruction.

Keep your machine in proper working condition. Unauthorized modifications to the machine may impair the function and/or safety and affect machine life.

If you do not understand any part of this manual and need assistance, contact your John Deere dealer.

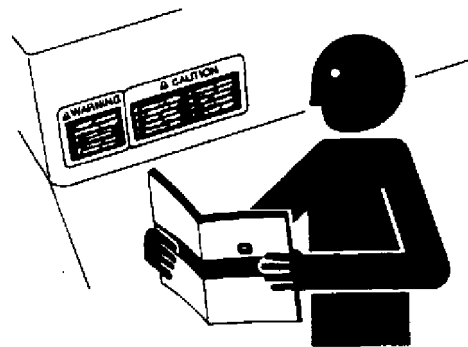

DX,READ -19-03MAR93

T5201 -UN-23AUG88

UNDERSTAND SIGNAL WORDS

A signal word—DANGER, WARNING, or CAUTION—is used with the safety-alert symbol. DANGER identifies the most serious hazards.

DANGER or WARNING safety signs are located near specific hazards. General precautions are listed on CAUTION safety signs. CAUTION also calls attention to safety messages in this manual.



DX,SIGNAL -19-03MAR93

T5187 -19-30SEP88



OBSERVE ROAD TRAFFIC REGULATIONS

Always observe local road traffic regulations when using public roads.



H28930 -UN-30JUN89

FX,ROAD -19-01MAY91

TRANSPORT SAFELY

Never tow the mower-conditioner faster than 25 km/h (15.5 mph).

Be sure reflectors and warning lights are clean and visible.

Before transporting mower-conditioner, fully raise and secure platform. Move the mower-conditioner tongue to transport position.

CC,1350MC001787-19-23AUG94

STORE ATTACHMENTS SAFELY

Stored attachments such as dual wheels, cage wheels, and loaders can fall and cause serious injury or death.

Securely store attachments and implements to prevent falling. Keep playing children and bystanders away from storage area.

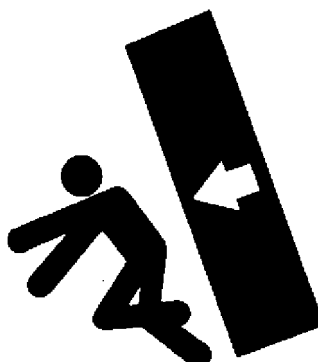

TS219 -UN-23AUG88

DX,STORE -19-03MAR93



PREPARE FOR EMERGENCIES

Be prepared if a fire starts.

Keep a first aid kit and fire extinguisher handy.

Keep emergency numbers for doctors, ambulance service, hospital, and fire department near your telephone.

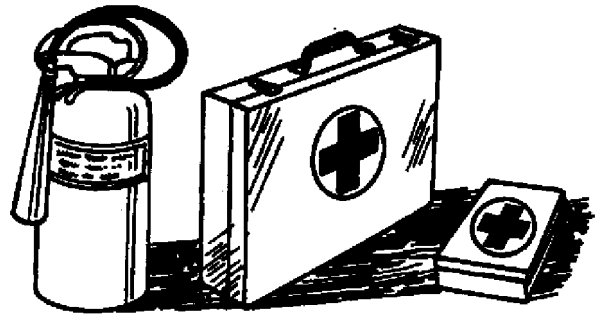

DX.FIRE2 -19-03MAR93

TS291 -UN-23AUG88

WEAR PROTECTIVE CLOTHING

Wear close fitting clothing and safety equipment appropriate to the job.

Prolonged exposure to loud noise can cause impairment or loss of hearing.

Wear a suitable hearing protective device such as earmuffs or earplugs to protect against objectionable or uncomfortable loud noises.

Operating equipment safely requires the full attention of the operator. Do not wear radio or music headphones while operating machine.

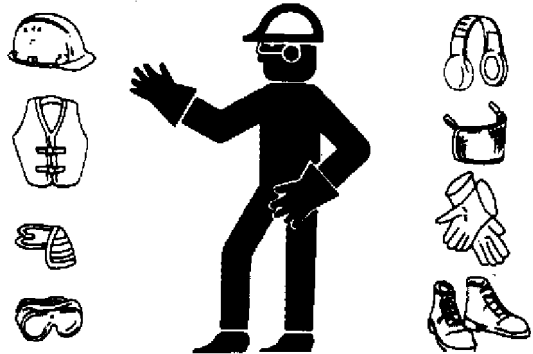

DX.WEAR -19-10SEP90

TS206 -UN-23AUG88

CHECK MACHINE SAFETY

Always check the road and general operating safety of the machine before using.

FX.READY -19-28FEB91



STAY CLEAR OF ROTATING DRIVELINES

Entanglement in rotating driveline can cause serious injury or death.

Keep tractor master shield and driveline shields in place at all times. Make sure rotating shields turn freely.

Wear close fitting clothing. Stop the engine and be sure PTO driveline is stopped before making adjustments, connections, or cleaning out PTO driven equipment.



DX,PTO -19-12SEP95

TS1644 -UN-22AUG95

OPERATE SAFELY

- Keep all curtains and shields in place.
- Never hand feed material into the machine.
- Do not lean against or sit or stand on the cutterbar curtains or their supporting framework.
- Do not operate mower-conditioner with cutterbar in raised position.
- Regularly check that disk and knife bolts are tight; also verify that tines are securely mounted on rotor.
- Always operate the machine at rated speed.
- Drive slowly over rough ground.
- Provide sufficient weight to stabilize the tractor when operating on hilly land or other adverse conditions. See your tractor operator's manual.

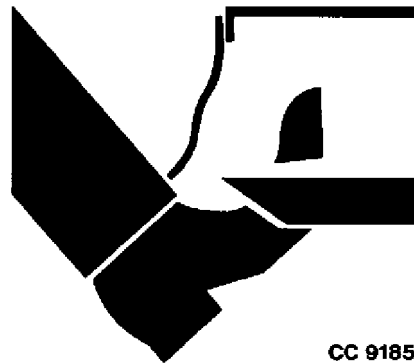

CC 9185

CC,1350MC001788-19-23AUG94

TS288 -UN-23AUG88

TS288

CC9185 -UN-07FEB95

CC9185



AVOID INJURY FROM THROWN OBJECTS

Extreme care must be exercised to avoid injury from thrown objects. Do not, under any circumstances, operate the mower-conditioner when other people are in the vicinity. Stones and other objects can be thrown great distances by the rotating cutting blades.

The cutterbar curtains are very important to reduce the potential for thrown objects. Always keep these curtains down when operating the mower-conditioner. Replace the curtains if they should become worn or damaged.

For additional operator protection from thrown objects, it is requested that the mower-conditioner be used only with tractors having an operator enclosure.

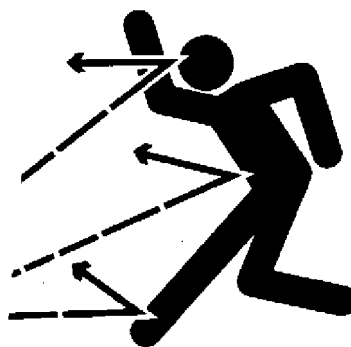

TS265 -UN-23AUG68

CC.MOCOUS000605-19-05OCT92

USE SAFETY LIGHTS AND DEVICES

Prevent collisions between other road users, slow moving tractors with attachments or towed equipment, and self-propelled machines on public roads. Frequently check for traffic from the rear, especially in turns, and use hand signals or turn signal lights.

Use headlights, flashing warning lights, and turn signals day and night. Follow local regulations for equipment lighting and marking. Keep lighting and marking visible and in good working order. Replace or repair lighting and marking that has been damaged or lost. An implement safety lighting kit is available from your John Deere dealer.

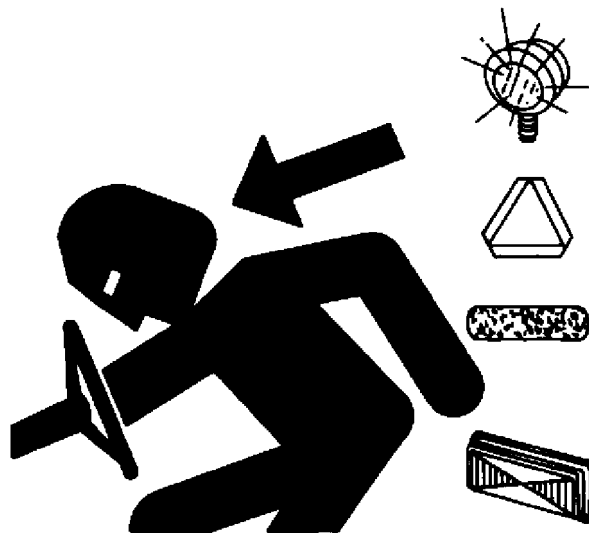

TS951 -UN-12APR90

DX,FLASH -19-12SEP95

Thank you so much for reading.
Please click the “Buy Now!”
button below to download the
complete manual.



After you pay.

You can download the most
perfect and complete manual in
the world immediately.

Our support email:

ebooklibonline@outlook.com