

# **787 Broadcast Attachments**

**John Deere Des Moines Works  
OMN200426 Issue J3  
(This manual replaces OMN200367 L2)**

LITHO IN U.S.A.  
ENGLISH

# Introduction

READ THIS MANUAL carefully to learn how to operate and service your machine correctly. Failure to do so could result in personal injury or equipment damage.

THIS MANUAL SHOULD BE CONSIDERED a permanent part of your machine and should remain with the machine when you sell it.

MEASUREMENTS in this manual are metric with the customary U.S. measurement following.

RIGHT-HAND AND LEFT-HAND sides are determined by facing in the direction of forward travel.

WRITE PRODUCT IDENTIFICATION NUMBERS in the Specifications section. Accurately record all the numbers to help in tracing the machine should it be stolen. Your dealer also needs these numbers when you order parts. If this manual is kept on the machine, also file the identification numbers in a secure place off the machine.

WARRANTY is provided as part of John Deere's support program for customers who operate and maintain their equipment as described in this manual. The warranty is explained on the warranty certificate which you should have received from your dealer.

This warranty provides you the assurance that John Deere will back its products where defects appear within the warranty period. In some circumstances, John Deere also provides field improvements, often without charge to the customer, even if the product is out of warranty. Should the equipment be abused, or modified to change its performance beyond the original factory specifications, the warranty will become void and field improvements may be denied. Setting fuel delivery above specifications or otherwise overpowering machines will result in such action.

THE TIRE MANUFACTURER'S warranty supplied with your machine may not apply outside the U.S.



*Seed Cart with Third Tank*

N44130  
-UN-03FEB92

# Safety

## RECOGNIZE SAFETY INFORMATION

This is the safety-alert symbol. When you see this symbol on your machine or in this manual, be alert to the potential for personal injury.

Follow recommended precautions and safe operating practices.

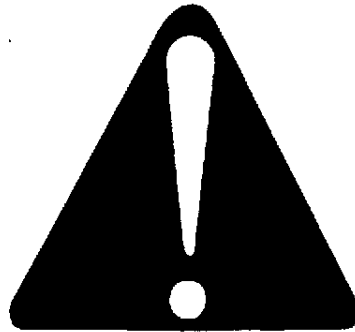

DX,ALERT -19-03MAR93

T81389 -UN-07DEC68

## UNDERSTAND SIGNAL WORDS

A signal word—DANGER, WARNING, or CAUTION—is used with the safety-alert symbol. DANGER identifies the most serious hazards.

DANGER or WARNING safety signs are located near specific hazards. General precautions are listed on CAUTION safety signs. CAUTION also calls attention to safety messages in this manual.



DX,SIGNAL -19-03MAR93

TS187 -19-30SEP88

## FOLLOW SAFETY INSTRUCTIONS

Carefully read all safety messages in this manual and on your machine safety signs. Keep safety signs in good condition. Replace missing or damaged safety signs. Be sure new equipment components and repair parts include the current safety signs. Replacement safety signs are available from your John Deere dealer.

Learn how to operate the machine and how to use controls properly. Do not let anyone operate without instruction.

Keep your machine in proper working condition. Unauthorized modifications to the machine may impair the function and/or safety and affect machine life.

If you do not understand any part of this manual and need assistance, contact your John Deere dealer.

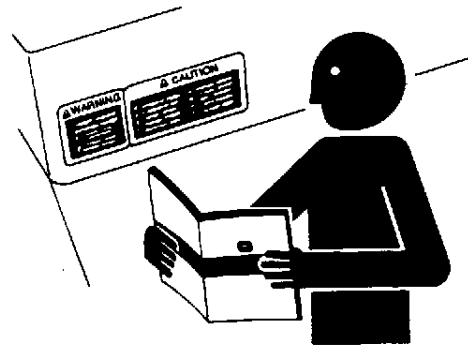

DX,READ -19-03MAR93

TS201 -UN-23AUG88



## OPERATE SAFELY

Clear area around machine before raising or lowering machine or wings.

Stop tractor on level ground when raising or lowering wings.

DO NOT enter tank unless another person is present and hydraulic hoses are disconnected from tractor.

Operate machine from the tractor seat only.

Lock auger in transport position before operating in the field.

Do not operate with wings raised.

Do not operate close to a ditch or creek.

Slow down when turning or traveling over rough ground.

Shut off tractor and shift to "Park" or set brakes when leaving tractor. Remove key when leaving tractor unattended.

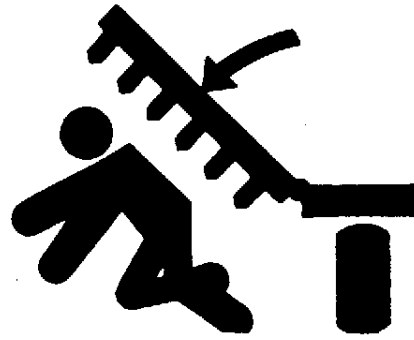

N39547 -UN-06OCT88

1N4,777C,A28 -19-18DEC91

## STAY CLEAR OF AIR HOSES

Stay clear of hoses when air seeder fan is running. Seed or fertilizer blowing out at high speed can cause blindness and other personal injuries.

Never attempt to clear blockage from air hoses or seeding tool boots while fan is running.



TS265 -UN-23AUG88

1N4,610STC,A18 -19-14OCT88



## USE A SIGNAL PERSON

Use a signal person to direct movement of the tractor/seed cart/seeding tool combination, whenever the tractor operator's view is obstructed.

Designate one individual as THE signal person. Always have signal person stand in clear view. Be sure signal person stays a safe distance away from the machine when it is moving.

Prior to starting the tractor, discuss hand signals and what each signal means to avoid misunderstandings and confusion which could result in a serious injury or fatal accident for someone.

Keep all bystanders away whenever the machine is moved.

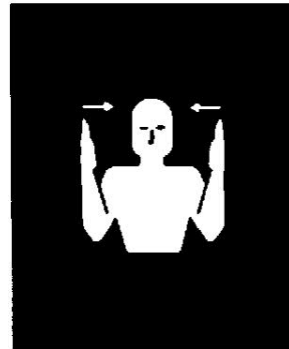

N43984 -UN-11DEC91

NX,787C,A2 -19-18DEC91

## KEEP SHIELDS IN PLACE

Do not operate air seeder without safety shields in place.

Rotating parts can crush or dismember causing death or personal injury.

Shut off tractor and disconnect hydraulic hose before remove shields for adjustment or service.



TS268 -UN-23AUG88

1N4,777C,A32 -19-01FEB89



## PARK SAFELY

Park machine on a level surface and block wheels.

Secure hitch jack(s) with pin(s).



*Tow Between*



*Tow Behind*

NX,787C,A1 -19-25OCT91

N43909 -UN-28OCT91

N40768 -UN-26NOV90

## WEAR PROTECTIVE CLOTHING

Wear close fitting clothing and safety equipment appropriate to the job.

Operating equipment safely requires the full attention of the operator. Do not wear radio or music headphones while operating machine.

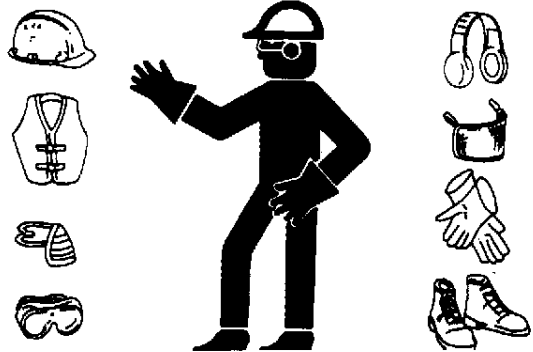

DX,WEAR2 -19-03MAR93

TS206 -UN-23AUG88



## HANDLE PESTICIDES AND FERTILIZERS CAREFULLY

Keep dust away from skin and hair.

Keep containers low when pouring.

Let the wind blow fumes away from you when mixing with seed or when filling tank.

Wear a filtered respirator if you cannot avoid dust.

Wear goggles to protect your eyes.

Wash exposed skin areas frequently—do not leave pesticide on your skin.

Do not smoke while handling pesticides.

Properly dispose of pesticide container, unused pesticide and left-over treated seed and fertilizer.

Read and observe manufacturers recommendations.

Store pesticides in a separate, plainly marked LOCKED building.

Store pesticides in original containers with labels intact.

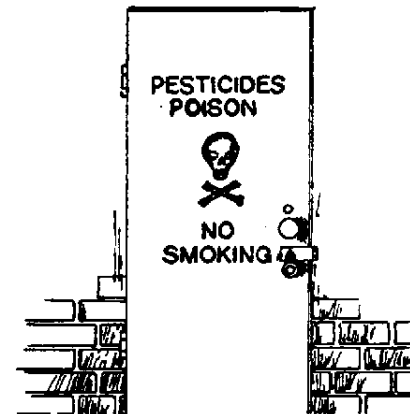

N35988 -UN-04OCT88

N35988

N35989 -UN-04OCT88

N35989

N33983 -19-31JAN89

N33983

N04.655C.A -19-05APR84



## KEEP RIDERS OFF MACHINE

Keep riders off.

Riders are subject to injury such as being struck by foreign objects and being thrown off the machine. Riders also obstruct the operator's view resulting in the machine being operated in an unsafe manner.



N40002  
-UN-28SEP88

1N4,610C,A2 -19-21JUN88

## USE SAFETY LIGHTS AND DEVICES

Slow moving tractors, self-propelled equipment and towed implements or attachments can create a hazard when driven on public roads. They are difficult to see, especially at night. Avoid personal injury or death resulting from collision with a vehicle.

Whenever driving on public roads, use flashing warning lights and turn signal according to local regulation. To increase visibility, use the lights and devices provided with your machine. For some equipment, install extra flashing warning lights.

Keep safety items in good condition. Replace missing or damaged items. An implement safety lighting kit is available from your John Deere dealer.

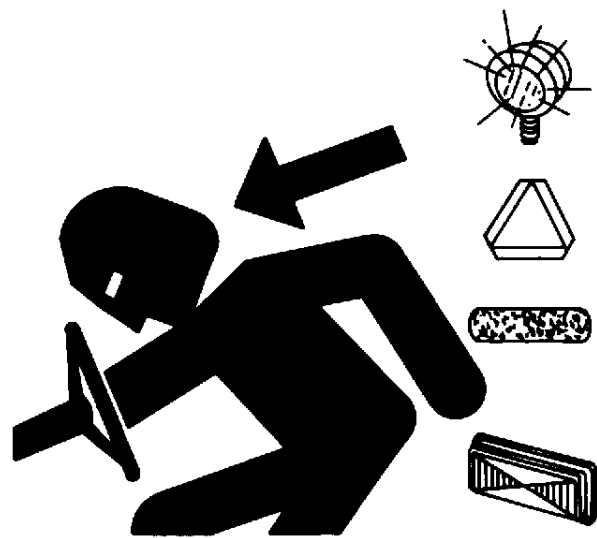

TS951  
-UN-12APR90

DX,FLASH -19-15MAR93

## USE A SAFETY CHAIN

A safety chain will help control drawn equipment should it accidentally separate from the drawbar.

Using the appropriate adapter parts, attach the chain to the tractor drawbar support or other specified anchor location. Provide only enough slack in the chain to permit turning.

See your John Deere dealer for a chain with a strength rating equal to or greater than the gross weight of the towed machine. Do not use safety chain for towing.

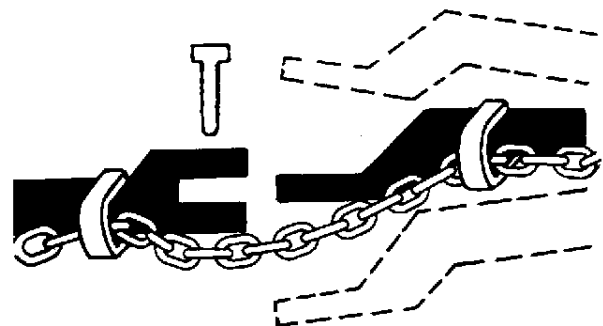

TS217  
-UN-23AUG88

DX,CHAIN -19-03MAR93





## TRANSPORT SAFELY

Keep away from overhead power lines. Serious injury or death may result. Know the transport height of your machine.

Always fold wings fully. If wing fold cylinders are removed, chain wings together to prevent accidental lowering.

Install transport lockups on depth control cylinders.

ALWAYS travel at a reasonable and safe speed.

Use transport hitch when traveling without seeding tool (tow behind models).

DO NOT use transport hitch with material in tank.

NEVER transport with air seeder fan running.

ALWAYS lock auger in transport position.

NEVER transport with meter shafts engaged.

Shift the tractor into a lower gear when transporting down steep slopes or hills.

Latch the tractor brakes together.

Stop slowly.

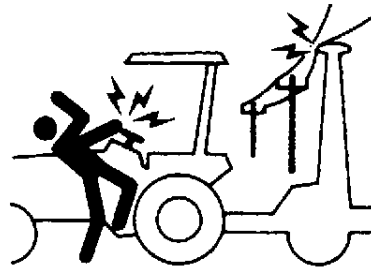

N39394 -UN-06OCT88

1N4,777C,A30A -19-09SEP91

## SERVICE MACHINE SAFELY

To help prevent personal injury caused by unexpected movement, be sure to service machine on level surface.

If machine is connected to tractor, engage parking brake and/or place transmission in "PARK", shut off engine and remove key.

If machine is detached from tractor, block wheels and use safety stands to prevent movement.

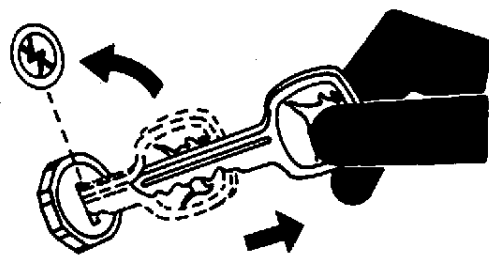

TS230 -UN-24MAY89

1N4,777C,A31 -19-11FEB88



## PRACTICE SAFE MAINTENANCE

Understand service procedure before doing work. Keep area clean and dry.

Never lubricate, service, or adjust machine while it is moving. Keep hands, feet, and clothing from power-driven parts. Disengage all power and operate controls to relieve pressure. Lower equipment to the ground. Stop the engine. Remove the key. Allow machine to cool.

Securely support any machine elements that must be raised for service work.

Keep all parts in good condition and properly installed. Fix damage immediately. Replace worn or broken parts. Remove any buildup of grease, oil, or debris.

Disconnect battery ground cable (-) before making adjustments on electrical systems or welding on machine.



DX,SERV -19-03MAR93

-UN-23AUG88  
TS218

## AVOID HIGH-PRESSURE FLUIDS

Escaping fluid under pressure can penetrate the skin causing serious injury.

Avoid the hazard by relieving pressure before disconnecting hydraulic or other lines. Tighten all connections before applying pressure.

Search for leaks with a piece of cardboard. Protect hands and body from high pressure fluids.

If an accident occurs, see a doctor immediately. Any fluid injected into the skin must be surgically removed within a few hours or gangrene may result. Doctors unfamiliar with this type of injury should reference a knowledgeable medical source. Such information is available from Deere & Company Medical Department in Moline, Illinois, U.S.A.

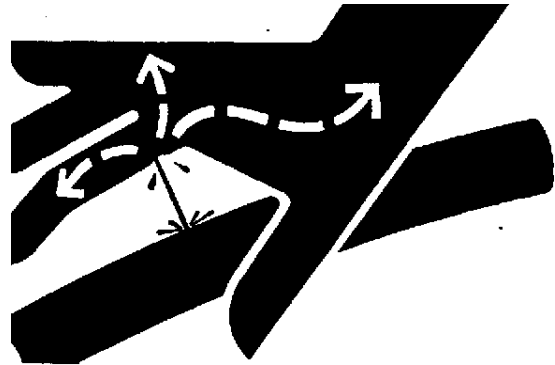

DX,FLUID -19-03MAR93

-UN-23AUG88  
X9811



## SERVICE TIRES SAFELY

**!** CAUTION: Explosive separation of a tire and rim parts can cause serious injury or death.

Only attempt to mount a tire if you have the proper equipment and experience to perform the job. Have it done by your John Deere dealer or a qualified tire repair service.

Always maintain the correct tire pressure. Do not inflate the tires above the recommended pressure.

When inflating tires, use a clip-on chuck and extension hose long enough to allow you to stand on one side and NOT in front of or over the tire assembly. Use a safety cage if available.

Inspect tires and wheels daily. Do not operate with low pressure, cuts, bubbles, damaged rims or missing lug bolts and nuts.

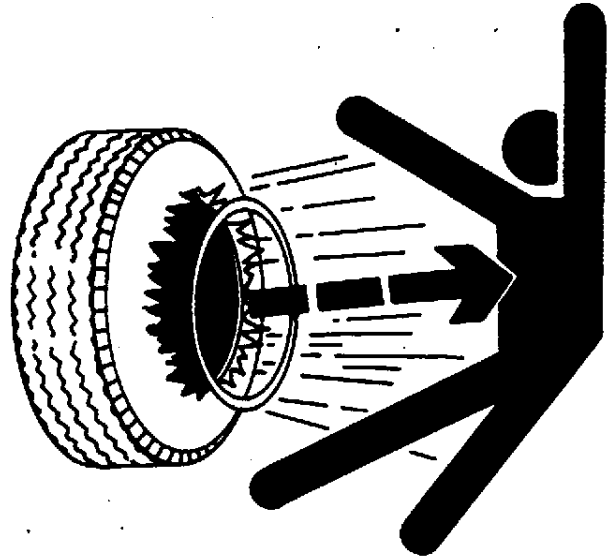

1N4,610C,A5 -19-27SEP91

-UN-23AUG88

TS211



## SAFETY SIGNS

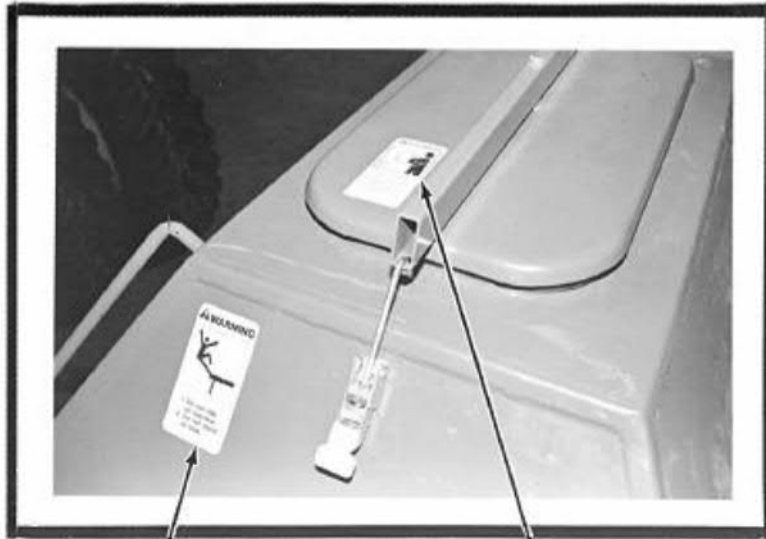

**! WARNING**



1. Do not ride on machine.
2. Do not stand on tank.

**! WARNING**



Chemicals may cause eye, skin, or breathing problems. Wear face mask, gloves, and goggles. Read and follow safety instructions on the chemical supplier's label.

-19-08APR02

N44091

NX,787GC,A1 -19-21JUL92

# Preparing the Tractor

## DETERMINING TRACTOR REQUIREMENTS

1. Tractor requirements for Broadcast Attachments are the same as 787 seed cart. Refer to Operator's manual for 787 Air Seeding System for tractor and hydraulic system specifications.
2. Install adapters, if tractor does not have ISO hydraulic couplers. See your John Deere dealer.

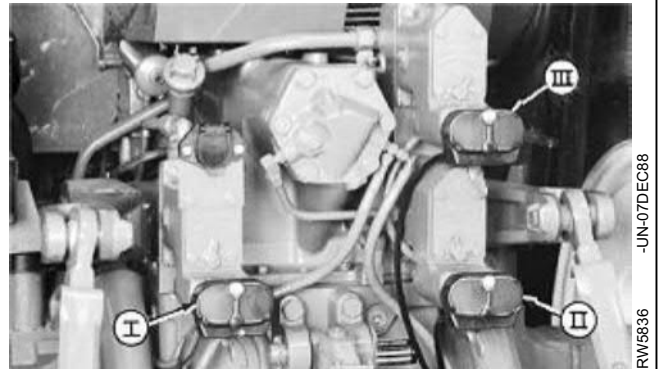

NX,787GV,A1 -19-21JUL92

RW5836  
-UN-07DEC88

**CAUTION:** Make sure tractor master shield (A) and driveline guard (B) are in place at all times, to prevent entanglement with rotating PTO shaft. Coming in contact with a rotating PTO shaft can severely injure or kill you.

3. Consult tractor operator's manual for specific adjustment procedures, tire inflation, wheel spacing, and ballast requirements.

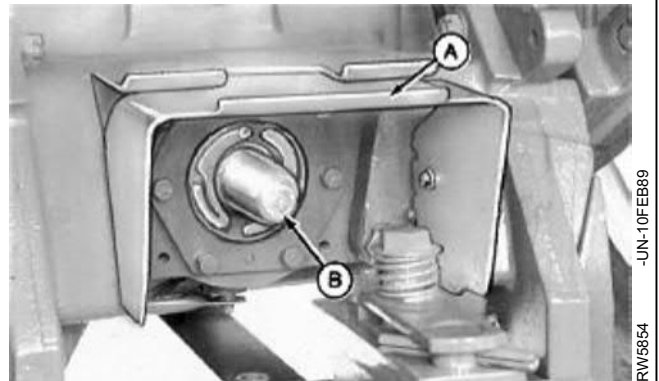

NX,1060SO,V2,A1-19-23SEP93

RW5854  
-UN-10FEB89

## SECURING 3-POINT HITCH

If equipped with quick-coupler, raise 3-point hitch fully.

If not equipped with quick-coupler, secure lift links (A) and center link (B) so they do not swing into tractor tires or onto hoses.

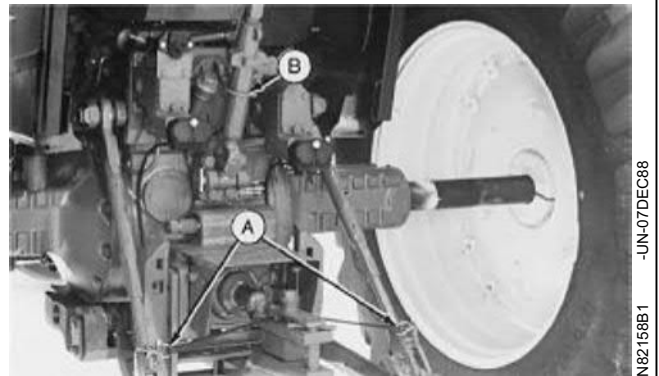

N03,940V,D -19-30OCT92

N82158B1  
-UN-07DEC88

## ADJUSTING METERING VALVES

Metering valve (A) is used to determine speed of hydraulic fan.

Refer to Setting Fan Speed in Operating the Machine section.



1N4,777V,A23 -19-01FEB89

RW5885  
-UN-07DEC88

## INSTALL LEVER LOCK CLIP

Install forward lever lock clip on No. 3 tractor control lever.

*NOTE: Installation instructions are in lever lock bundle.  
See Setting Fan Speed in Operating the Machine section for field operation.*

1N4,777V,A24 -19-27AUG91

## POSITIONING DRAWBAR

**⚠ CAUTION:** Avoid personal injury or death due to losing steering control of machine. Always pin drawbar in center position for ALL tractors, when transporting machine.

1. Place drawbar in fixed centered position, as close as possible to 457 mm (18 in.) from ground to top of drawbar. For tow-between cart use shortest drawbar possible or pin drawbar in innermost position.
2. Be sure clevis assembly (if equipped) is installed on top of drawbar.
3. Torque clevis assembly bolts to 407 N·m (300 lb-ft).

*NOTE: For four-wheel drive tractors, leave one hole clearance on each side of drawbar for field operation only.*

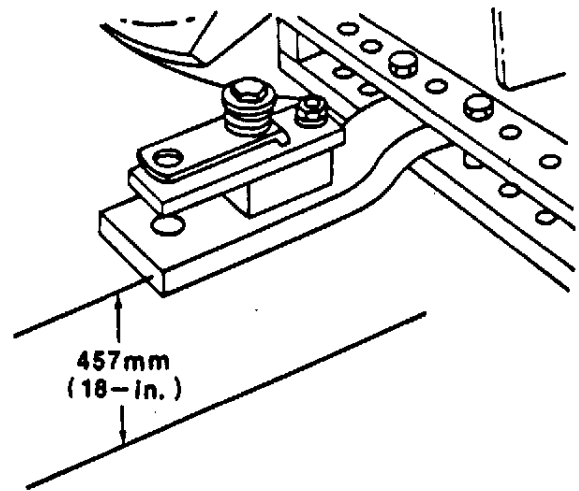

N42074N -UN-25SEP90

NX,787V,A3 -19-18DEC91

Thank you so much for reading.  
Please click the “Buy Now!”  
button below to download the  
complete manual.



After you pay.

You can download the most  
perfect and complete manual in  
the world immediately.

Our support email:

[ebooklibonline@outlook.com](mailto:ebooklibonline@outlook.com)