

**6610, 6710,  
6810 and 6910  
Self-Propelled  
Forage Harvesters**  
(From serial no. 501236)

**John Deere Werke Zweibrücken  
OMZ92304 Issue G4**

**European Edition**  
Printed in Germany  
**ENGLISCH**

# Contents

	Page		Page
<b>Identification View</b> . . . . .	00-1	Automatic kernel processor roll clearance . . .	20-21
		Manual kernel processor roll clearance . . . .	20-21
<b>Safety</b>		<b>Lighting System and Signals</b>	
General . . . . .	05-1	Parking lights/low-beam headlights . . . . .	25-1
Operation . . . . .	05-5	Full-beam headlights . . . . .	25-1
Service . . . . .	05-11	Turn signals . . . . .	25-2
<b>Safety Decals</b> . . . . .	10-1	Work lights . . . . .	25-4
		Revolving hazard warning lights . . . . .	25-5
<b>Controls and Instruments</b>		Hazard warning lights . . . . .	25-5
General view . . . . .	15-1	Indicator light test . . . . .	25-6
Switch console . . . . .	15-2	<b>Operator's Cab</b>	
Multi-function lever . . . . .	15-5	Operator's seat . . . . .	30-1
Corner post . . . . .	15-6	Lumbar support . . . . .	30-2
Roof switch console . . . . .	15-7	Left-hand armrest . . . . .	30-2
Roof console . . . . .	15-8	Right-hand armrest . . . . .	30-2
Automatic function control . . . . .	15-9	Ashtray . . . . .	30-4
Steering column . . . . .	15-10	Air comfort seat . . . . .	30-4
Switch console — functions . . . . .	15-11	Passenger seat . . . . .	30-4
Multi-function lever — functions . . . . .	15-18	Storage compartment for Operator's	
Roof switch console — functions . . . . .	15-20	Manuals . . . . .	30-5
Steering column — functions . . . . .	15-22	Cooling compartment . . . . .	30-5
<b>Warning Devices and Monitors</b>		Steering column . . . . .	30-6
Indicator lights I . . . . .	20-1	Foot brakes . . . . .	30-7
Indicator lights II . . . . .	20-4	Parking brake . . . . .	30-7
Fuel gauge . . . . .	20-7	Releasing parking brake . . . . .	30-7
Coolant temperature gauge . . . . .	20-7	Sun visor . . . . .	30-8
Automatic function control lights . . . . .	20-7	Inside mirror . . . . .	30-8
Infotrak monitor . . . . .	20-8	Outside mirror . . . . .	30-8
Cutterhead alarm speed . . . . .	20-10	Heater shut-off valve . . . . .	30-9
SERVICE information . . . . .	20-10	Adjustable air louvers . . . . .	30-9
Automatic function control . . . . .	20-11	Interior lighting . . . . .	30-10
Burnishing electromagnetic clutch . . . . .	20-12	Digital clock . . . . .	30-10
Sharpening cycles . . . . .	20-14	Radio and citizen band . . . . .	30-11
Automatic knife sharpening . . . . .	20-15	<b>Pre-Starting Checks</b>	
Sharpening stone home position (manual) . . .	20-17	Daily checks . . . . .	35-1
Automatic stationary knife adjustment . . . .	20-17	Engine oil level . . . . .	35-1
Manual stationary knife adjustment . . . . .	20-19	Hydraulic oil level . . . . .	35-1
Kernel processor roll clearance . . . . .	20-20	Fuel level . . . . .	35-2

Continued on next page

*All information, illustrations and specifications in this manual are based on the latest information available at the time of publication. The right is reserved to make changes at any time without notice.*

OMZ92304 G4-19-01JUL94

COPYRIGHT© 1994  
DEERE & COMPANY  
European Office Mannheim  
All rights reserved  
A John Deere ILLUSTRATION™ Manual

Page	Page		
Tires . . . . .	35-2	<b>Feeding System</b>	
Hydrostatic oil level . . . . .	35-2	Safety information . . . . .	70-1
Fuel system . . . . .	35-3	Electromagnetic clutch . . . . .	70-1
Lubricating forage harvester . . . . .	35-3	Cutterhead speed sending unit . . . . .	70-3
Checks in operator's cab . . . . .	35-3	Length-of-cut transmission . . . . .	70-3
<b>Operating the Engine</b>		Adjusting length-of-cut . . . . .	70-4
Starting the engine . . . . .	40-1	Harvesting unit speed . . . . .	70-5
Engine oil pressure indicator light . . . . .	40-4	Feed roll slip clutch . . . . .	70-6
Warming up the engine . . . . .	40-4	Length-of-cut transmission service . . . . .	70-6
Engine idle . . . . .	40-4	Feed roll drive . . . . .	70-8
Ether starting aid . . . . .	40-5	Replacing wear plates . . . . .	70-8
Coolant heater . . . . .	40-8	Adjusting feed roll springs . . . . .	70-10
Slave battery . . . . .	40-9	Opening feed roll housing . . . . .	70-10
Stopping the engine . . . . .	40-10	Smooth roll scraper . . . . .	70-12
Cold weather operation . . . . .	40-10	Closing feed roll housing . . . . .	70-13
<b>Driving and Transporting Forage Harvester</b>		Feed roll housing safety switch . . . . .	70-13
Driving the forage harvester . . . . .	45-1	Hydraulic reverser motor . . . . .	70-14
Releasing parking brake . . . . .	45-1	Troubleshooting — feeding system . . . . .	70-15
Operating the foot brakes . . . . .	45-2	<b>Metal Detector</b>	
Engaging a gear . . . . .	45-2	Metal detector operation . . . . .	75-1
Road safety switch . . . . .	45-3	Activating metal detector . . . . .	75-2
Adjusting engine speed . . . . .	45-3	Operation without metal detector . . . . .	75-3
Forward and reverse travel . . . . .	45-4	When ferrous metal is detected . . . . .	75-4
Travel speed . . . . .	45-4	Adjusting locking pawl . . . . .	75-5
Hydrostatic system . . . . .	45-5	Metal detector test . . . . .	75-7
Four-wheel drive . . . . .	45-6	Safety information . . . . .	75-9
Transport information . . . . .	45-7	Electronic box . . . . .	75-10
<b>Wheels and Ballast</b>		Relay box . . . . .	75-11
Tire maintenance . . . . .	50-1	Indicator light test chart . . . . .	75-16
Tire pressures . . . . .	50-6	Test charts . . . . .	75-17
Rear weights . . . . .	50-7	Troubleshooting . . . . .	75-19
<b>Harvesting Units and Attachments</b> . . . . .	55-1	<b>Cutterhead and Drive</b>	
<b>Attaching and Detaching Harvesting Units</b>		Drive . . . . .	80-1
Attaching 6-row row crop unit . . . . .	60-1	Main clutch . . . . .	80-2
Attaching 4.5 meter pickup . . . . .	60-4	Replacing main drive belt . . . . .	80-4
<b>Preparations and Field Operation</b>		Checking belt alignment . . . . .	80-7
Preparations for harvesting grass . . . . .	65-1	Cutterhead knives . . . . .	80-8
Preparations for harvesting corn . . . . .	65-1	Replacing partial set of knives . . . . .	80-10
Preparations for whole plant silage . . . . .	65-1	Replacing complete set of knives . . . . .	80-11
Preparations for ear corn silage . . . . .	65-1	Replacing clamp bar . . . . .	80-13
Field operation of forage harvester . . . . .	65-2	Replacing threaded bar . . . . .	80-13
Reverser operation . . . . .	65-7	Knife torque . . . . .	80-14
Harvesting unit float system . . . . .	65-8	Preparations for knife sharpening . . . . .	80-14
		Manual knife sharpening . . . . .	80-15
		Automatic knife sharpening device . . . . .	80-19
		Replacing sharpening stone . . . . .	80-21
		Aligning knife sharpening device . . . . .	80-23
		Sharpening stone end switch . . . . .	80-24

Continued on next page

## Contents

	Page		Page
Stationary knife . . . . .	80-26	Installing wear plate . . . . .	90-4
Checking stationary knife . . . . .	80-31	Installing blower paddles . . . . .	90-5
Removing stationary knife . . . . .	80-32	Adjusting blower paddles . . . . .	90-6
Installing stationary knife . . . . .	80-33	Adjusting deflecting edges . . . . .	90-6
Eliminating end play of adjusting spindle . . . . .	80-35	Spout base service covers . . . . .	90-7
Bottom and outlet bands . . . . .	80-37	Spout worm gear and ring gear . . . . .	90-9
Adjusting bottom band . . . . .	80-37		
Adjusting outlet band . . . . .	80-38	<b>Fuel, Lubricants, Coolant and Capacities</b>	
Recirculating screens . . . . .	80-40	Fuel . . . . .	95-1
Installing/changing recirculating screens . . . . .	80-40	Engine oil . . . . .	95-2
Adjusting recirculating screen . . . . .	80-43	Engine coolant . . . . .	95-4
Installing spiral floor . . . . .	80-45	Gear oil . . . . .	95-5
Cutterhead service cover . . . . .	80-47	Brake fluid . . . . .	95-8
Transition chute . . . . .	80-48	Grease . . . . .	95-9
Removing cutterhead with harvesting unit . . . . .	80-49		
Installing cutterhead with harvesting unit . . . . .	80-53	<b>Lubrication, Periodic Services</b>	
Troubleshooting — main drive . . . . .	80-54	Lubrication charts . . . . .	100-1
Troubleshooting — cutterhead . . . . .	80-55	Break-in service . . . . .	100-9
Troubleshooting — knife sharpener . . . . .	80-56	Service intervals . . . . .	100-9
Troubleshooting — stationary knife . . . . .	80-58	After the first 100 operating hours . . . . .	100-11
		Every 250 operating hours . . . . .	100-11
		Every 500 operating hours . . . . .	100-12
		Every 1000 operating hours . . . . .	100-12
		Every 1500 operating hours . . . . .	100-12
		Every 2000 operating hours . . . . .	100-13
		As required . . . . .	100-13
		Every year . . . . .	100-13
		Every 2 years . . . . .	100-13
		V-belts . . . . .	100-14
		Chains . . . . .	100-14
<b>Kernel Processor</b>		<b>Service — Engine</b>	
Installing kernel processor . . . . .	85-1	Engine access . . . . .	105-1
Preparing kernel processor . . . . .	85-4	Engine compartment . . . . .	105-1
Attaching kernel processor . . . . .	85-6	Adjusting engine valve tappets . . . . .	105-2
Drive belts . . . . .	85-7	Rocker arm cover ventilation . . . . .	105-2
Breaking-in kernel processor . . . . .	85-9	Checking engine crankcase oil level . . . . .	105-4
Field operation . . . . .	85-10	Changing engine oil and filter . . . . .	105-5
Kernel processor service . . . . .	85-10	Service — fuel system . . . . .	105-9
Adjusting roll spacing . . . . .	85-11	Fuel tank filler neck . . . . .	105-10
Adjusting clearance indicator . . . . .	85-12	Fuel tank water trap . . . . .	105-11
Pretension lower roll drive belt . . . . .	85-12	Fuel system, John Deere engine . . . . .	105-12
Adjusting scrapers . . . . .	85-13	Fuel system, Cummins engine . . . . .	105-13
Roll wear and replacement . . . . .	85-13	Fuel shut-off valve . . . . .	105-13
Potentiometer, automatic adjustment . . . . .	85-14	Water trap, John Deere engine . . . . .	105-14
Replacing lower roll drive belts . . . . .	85-14	Fuel filter, John Deere engine . . . . .	105-15
Troubleshooting . . . . .	85-15	Checking fuel injection nozzles . . . . .	105-15
		Bleeding fuel system . . . . .	105-16
		Fuel filter, Cummins engine . . . . .	105-18
		Bleed line and valve . . . . .	105-19
<b>Power Chute</b>			
Installing power chute . . . . .	86-1		
Preparing power chute . . . . .	86-2		
Attaching power chute . . . . .	86-3		
Drive belts . . . . .	86-4		
Tensioning drive belt . . . . .	86-5		
<b>Discharge</b>			
Blower and discharge spout . . . . .	90-1		
Blower bottom . . . . .	90-1		
Replacing wear plate . . . . .	90-1		
Checking parts for wear . . . . .	90-4		

Continued on next page

## Contents

	<b>Page</b>		<b>Page</b>
Fuel shut-off valve . . . . .	105-19	Brake fluid reservoir . . . . .	120-2
Trailer hitch . . . . .	105-19	Adjusting foot brakes . . . . .	120-2
Rotary radiator screen . . . . .	105-20	Parking brake . . . . .	120-2
Flushing cooling system . . . . .	105-23	Hydrostatic drive components . . . . .	120-3
Replacing coolant conditioner . . . . .	105-28	Oil cooler . . . . .	120-4
Drive belts . . . . .	105-30	Oil and filter change . . . . .	120-4
Air intake system . . . . .	105-33	Transmission . . . . .	120-5
Air intake prefilter screen . . . . .	105-35	Final drives . . . . .	120-5
Air cleaner . . . . .	105-35	Front axle . . . . .	120-6
Turbocharger . . . . .	105-40	Rear axle toe-in . . . . .	120-6
Vibration damper . . . . .	105-41	Steering system components . . . . .	120-9
 <b>Service — Electrical System</b>		 <b>Service — Air Conditioning System, Heater</b>	
Specifications . . . . .	110-1	Air conditioning system components . . . . .	125-1
Batteries . . . . .	110-1	Heater components . . . . .	125-2
Alternators . . . . .	110-4	Operating air conditioning system . . . . .	125-4
Starting motor . . . . .	110-5	Compressor . . . . .	125-5
Access to fuse board . . . . .	110-6	Refrigerant level . . . . .	125-5
Fuse tester . . . . .	110-6	Low pressure switch . . . . .	125-6
Access to circuit boards . . . . .	110-7	High pressure switch . . . . .	125-6
Access to electronic control unit . . . . .	110-8	Cleaning condenser . . . . .	125-7
Access to relay and diode board . . . . .	110-9	Cab filter . . . . .	125-7
Sockets . . . . .	110-9	Air intake opening . . . . .	125-9
Electronic system boards . . . . .	110-10	Condensed water drain hose . . . . .	125-9
Fuse board — fuses . . . . .	110-11	 <b>Storage</b>	
Fuse board — relays . . . . .	110-13	After the season . . . . .	130-1
Relay and diode board . . . . .	110-14	Removing harvester from storage . . . . .	130-3
Solenoids . . . . .	110-15	 <b>Specifications</b>	
Electrical system operation . . . . .	110-19	 <b>Serial Numbers</b>	
Error codes . . . . .	110-29	Serial number plates . . . . .	140-1
Work lights . . . . .	110-37	Serial numbers . . . . .	140-2
Headlights . . . . .	110-39	 <b>Index</b>	
Clearance and turn signal lights, front . . . . .	110-39		
Tail, stop and turn signal lights, rear . . . . .	110-40		
Dome light . . . . .	110-40		
Switch lighting . . . . .	110-40		
Indicator light bulbs . . . . .	110-41		
 <b>Service — Hydraulic System</b>			
Pressure relief valve . . . . .	115-1		
System operation . . . . .	115-2		
Accumulators . . . . .	115-3		
Hydraulic components — neutral oil flow . . . . .	115-4		
Draining hydraulic oil . . . . .	115-7		
Replacing hydraulic oil filter . . . . .	115-7		
Refilling hydraulic oil . . . . .	115-8		
Temperature and pressure sending units . . . . .	115-8		
 <b>Service — Ground Speed Drive</b>			
Brake system . . . . .	120-1		

# Identification View

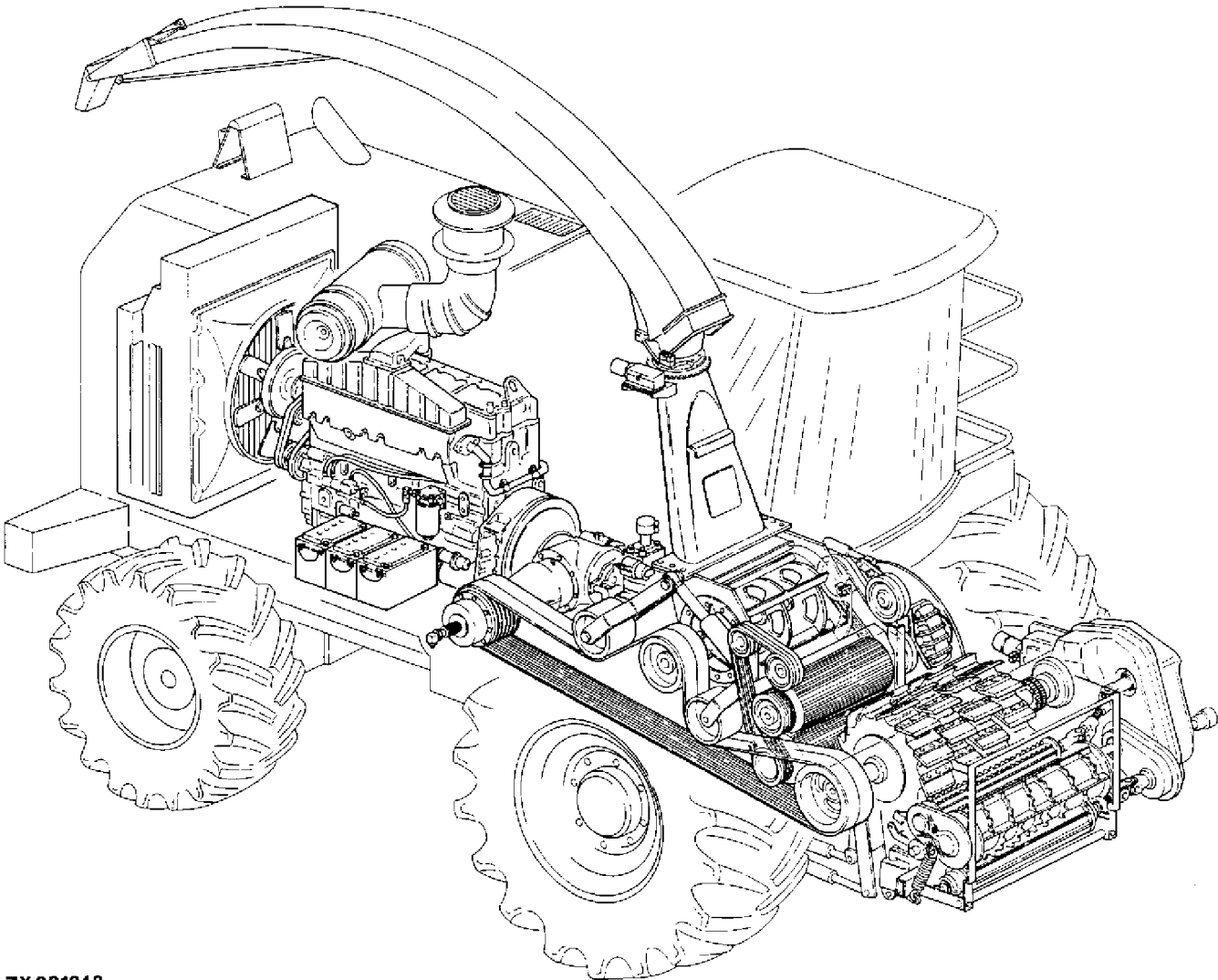

ZX001242

ZX001242 -JUN-08FEB96

ZX,OMSPFH,TYP -19-01NOV91

# Safety

## RECOGNIZE SAFETY INFORMATION

This is the safety-alert symbol. When you see this symbol on your machine or in this manual, be alert to the potential for personal injury.

Follow recommended precautions and safe operating practices.

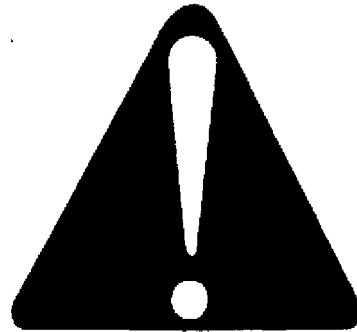

DX,ALERT -19-03MAR93

T81389 -UN-07DEC68

## FOLLOW SAFETY INSTRUCTIONS

Carefully read all safety messages in this manual and on your machine safety signs. Keep safety signs in good condition. Replace missing or damaged safety signs. Be sure new equipment components and repair parts include the current safety signs. Replacement safety signs are available from your John Deere dealer.

Learn how to operate the machine and how to use controls properly. Do not let anyone operate without instruction.

Keep your machine in proper working condition. Unauthorized modifications to the machine may impair the function and/or safety and affect machine life.

If you do not understand any part of this manual and need assistance, contact your John Deere dealer.

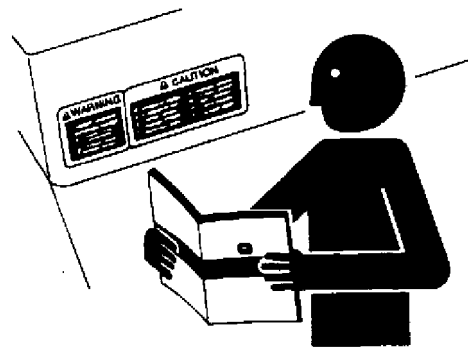

DX,READ -19-03MAR93

T5201 -UN-23AUG88

## UNDERSTAND SIGNAL WORDS

A signal word—DANGER, WARNING, or CAUTION—is used with the safety-alert symbol. DANGER identifies the most serious hazards.

DANGER or WARNING safety signs are located near specific hazards. General precautions are listed on CAUTION safety signs. CAUTION also calls attention to safety messages in this manual.



DX,SIGNAL -19-03MAR93

TS187 -19-30SEP88



## OBSERVE ROAD TRAFFIC REGULATIONS

Always observe local road traffic regulations when using public roads.



H28930 -UN-30JUN89

FX,ROAD -19-01MAY91



**CAUTION: Avoid possible injury or death from machinery runaway.**

**Do not start engine by shorting across starter terminals. Machine will start in gear if normal circuitry is bypassed.**

**NEVER start engine while standing on ground. Start engine only from operator's seat, with transmission in neutral or park.**

DX,BYPAS -19-26JAN90





## USE SAFETY LIGHTS AND DEVICES

Slow moving tractors, self-propelled equipment and towed implements or attachments can create a hazard when driving on public roads. They are difficult to see, especially at night. Avoid personal injury or death resulting from collision with a vehicle.

If legally permitted, use flashing warning lights or rotary beacons whenever driving on public roads. To increase visibility, use the lights and devices provided with your machine. For some equipment, install additional flashing warning lights.

Keep safety items in good condition. Replace missing or damaged items. An implement safety lighting kit is available from your John Deere dealer.

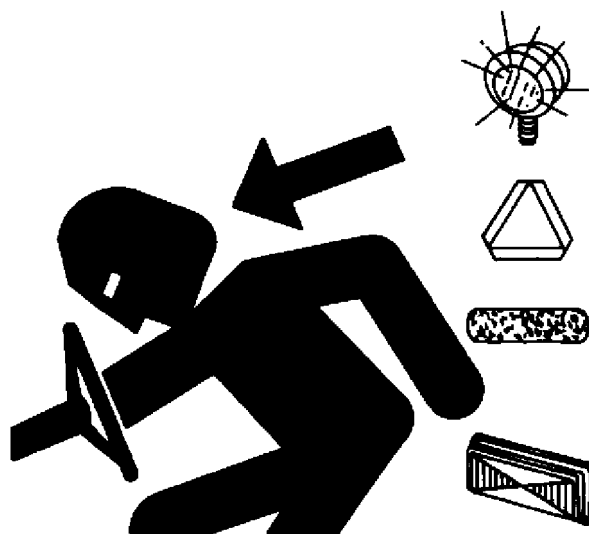

TS951  
-UN-12APR90

ZX,FLASH -19-01OCT91

## PREPARE FOR EMERGENCIES

Be prepared if a fire starts.

Keep a first aid kit and fire extinguisher handy.

Keep emergency numbers for doctors, ambulance service, hospital, and fire department near your telephone.

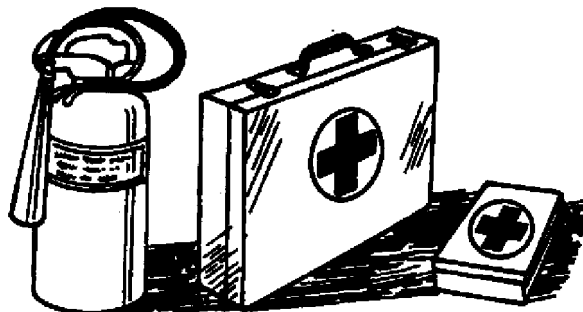

TS291  
-UN-23AUG88

DX,FIRE2 -19-03MAR93



## WEAR PROTECTIVE CLOTHING

Wear close fitting clothing and safety equipment appropriate to the job.

Prolonged exposure to loud noise can cause impairment or loss of hearing.

Wear a suitable hearing protective device such as earmuffs or earplugs to protect against objectionable or uncomfortable loud noises.

Operating equipment safely requires the full attention of the operator. Do not wear radio or music headphones while operating machine.

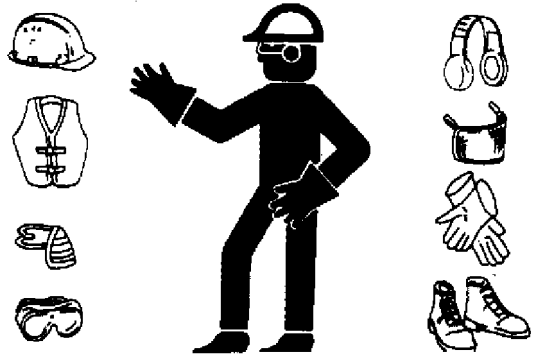

DX,WEAR -19-10SEP90

TS206 -UN-23AUG88

## HANDLE FUEL SAFELY—AVOID FIRES

Handle fuel with care: it is highly flammable. Do not refuel the machine while smoking or when near open flame or sparks.

Always stop engine before refueling machine. Fill fuel tank outdoors.

Prevent fires by keeping machine clean of accumulated trash, grease, and debris. Always clean up spilled fuel.



DX,FIRE1 -19-03MAR93

TS202 -UN-23AUG88

## STORE ATTACHMENTS SAFELY

Stored attachments such as dual wheels, cage wheels, and loaders can fall and cause serious injury or death.

Securely store attachments and implements to prevent falling. Keep playing children and bystanders away from storage area.

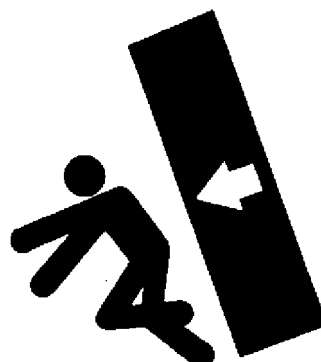

DX,STORE -19-03MAR93

TS219 -UN-23AUG88



## HANDLE STARTING FLUID SAFELY

Starting fluid is highly flammable.

Keep all sparks and flame away when using it. Keep starting fluid away from batteries and cables.

To prevent accidental discharge when storing the pressurized can, keep the cap on the container, and store in a cool, protected location.

Do not incinerate or puncture a starting fluid container.



DX,FIRE3 -19-16APR92

TS1356 -UN-18MAR92

## FIRE EXTINGUISHER

A 6 kg (13 lb) general purpose fire extinguisher complying with legal regulations must be installed on the left-hand side of the operator's platform.

Make sure that the fire extinguisher is always ready for operation.

Keep the engine clean and free of dust, chaff and straw to prevent the possibility of a fire.

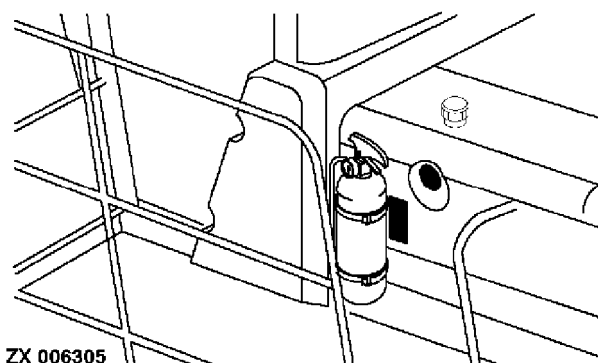

ZX 006305

ZX,FIRESPFH -19-01JUN94

-UN-03APR95  
ZX006305

## CHECK MACHINE SAFETY

Always check the road and general operating safety of the machine before using.

FX,READY -19-28FEB91



## MOUNT AND DISMOUNT SAFELY

Use handrail when mounting or dismounting the harvester.

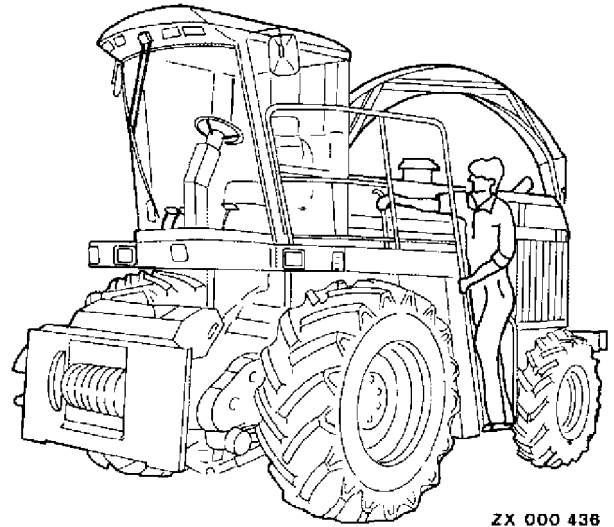

ZX 000 436

ZX000436  
-UN-03APR95

ZX,HANDLE -19-01OCT91

## OPERATE SAFELY

All machinery should only be operated by responsible adults who have been properly instructed and delegated to do so.

Never stand in the discharge spout path while cutterhead and fan are turning.

Never open cutterhead or fan housing doors while cutterhead is turning.

Always operate machine at rated speed.

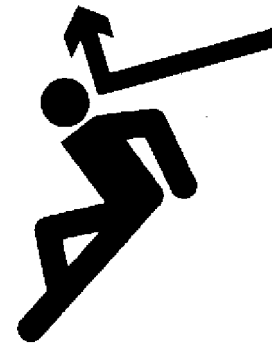

-UN-23AUG88

T5263

ZX,CAUTION -19-01OCT91

## RIDERS

Only allow the operator and one rider on the machine.

Other riders are subject to injury such as being thrown off the machine and obstruct the operator's view resulting in the machine being operated in an unsafe manner.

One rider is permitted, since the machine is equipped with a factory-approved passenger seat.



-UN-23AUG88

T5253

ZX,PASSENGER -19-02OCT91



## ROAD SAFETY SWITCH

**IMPORTANT:** Before driving forage harvester on public roads, make sure that the road safety switch is in the road position.

This ensures that all the hydraulic functions with the exception of the steering are switched off.

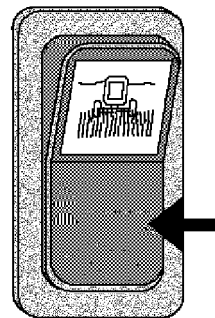

ZX 002418

ZX, SWITCH -19-01MAY94

ZX002418 -UN-16JUN95

## DRIVING THE FORAGE HARVESTER

Operate machine only when all guards are correctly installed.

Before moving away, always check immediate vicinity of machine (e.g. for children). Ensure adequate visibility. Use the horn as a warning immediately before moving away.

Always adapt ground speed to road or field conditions. Avoid making sharp turns when driving up or down slopes or when driving across a slope.

Attach harvesting units and other implements to forage harvester with extreme care.

When making turns, always take into consideration the width of the attachment and the fact that the rear end of the forage harvester swings out. Attachments and ground conditions affect the driving characteristics of the harvester.

Reduce ground speed when driving on slopes or over uneven ground and before making sharp turns. Before descending a steep hill, shift to a lower gear.

Avoid holes, ditches and obstructions which may cause the forage harvester to tip, particularly on hillsides.

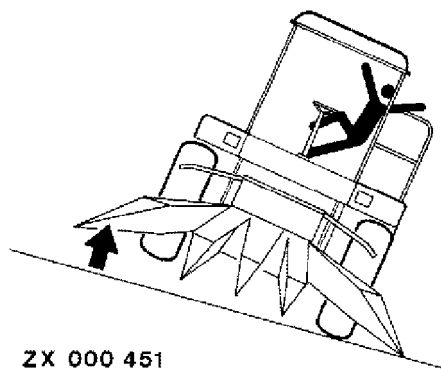

ZX 000 451

ZX000451 -UN-05APR95

ZX, DRIVE -19-02OCT91



## GUARDS AND SHIELDS

Keep guards and shields in place at all times. Ensure that they are serviceable and installed correctly.

Always disengage main clutch, shut off engine and remove key before removing any guards or shields.

Keep hands, feet and clothing away from moving parts.

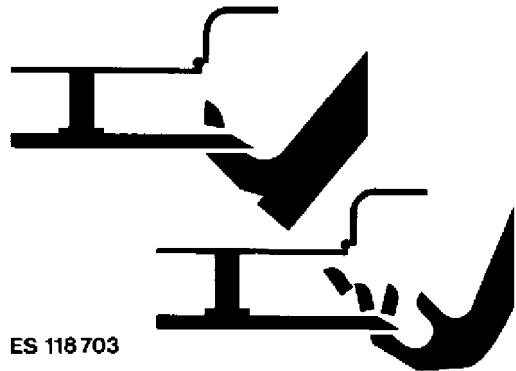

ES 118 703

FX,DEVICE -19-04DEC90

ES118703 -UN-21MAR95

## STAY CLEAR OF HARVESTING UNITS

Cutterbar, auger, reel and feed rolls cannot be completely shielded due to their function. Stay clear of these moving elements during operation. Always disengage main clutch, shut off engine and remove key before servicing or unclogging machine.



ES 118 704

FX,CUT -19-21DEC90

ES118704 -UN-21MAR95

## KEEP HANDS AWAY FROM KNIVES

Never attempt to clear obstructions in front of or on harvesting unit unless main clutch is disengaged, engine shut off and key removed.

Everyone must be clear of the forage harvester before starting the engine.



FX,KNIFE -19-21DEC90

TS254 -UN-23AUG88

## STAY CLEAR OF ROTATING DRIVELINES

Entanglement in rotating driveline can cause serious injury or death.

Keep tractor master shield and driveline shields in place at all times. Make sure rotating shields turn freely.

Wear close fitting clothing. Stop the engine and be sure PTO driveline is stopped before making adjustments, connections, or cleaning out PTO driven equipment.



DX,PTO -19-03MAR93

TS198 -UN-23AUG88



## AVOID ENTANGLEMENT

To avoid entanglement, do not feed crop into machine by hand or attempt to manually unplug machine while it is running. The feed rolls can feed crop material in faster than you can release your grip on the material.

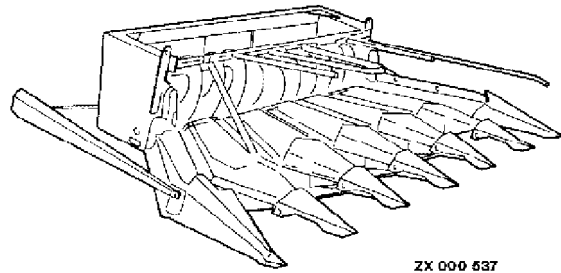

ZX 000 537

-UN-03APR95

ZX000537

ZX.FEEDROLL -19-04DEC90

## TRANSPORT WITH HARVESTING UNIT INSTALLED

Before driving forage harvester on public roads, harvesting unit must be raised and secured in this position. It must not, however, obstruct operator's view of the road. Remove crop dividers (if equipped) and install protective cover.

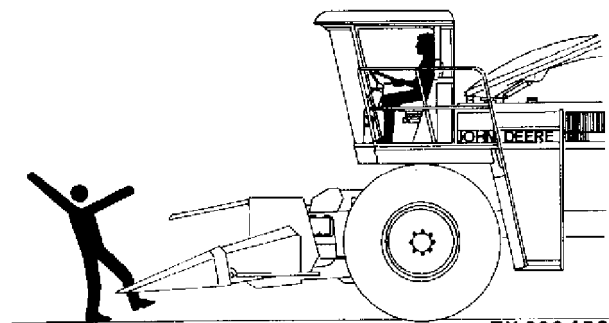

ZX 000 452

-UN-03APR95

ZX000452

ZX.HEADER -19-04DEC90

## BALLASTING FOR SAFE GROUND CONTACT

Operating, steering and braking performance of forage harvester can be considerably affected by attachments which alter the center of gravity of the machine. To maintain safe ground contact, ballast the harvester at the rear end as necessary. Observe the maximum permissible axle loads and total weights.

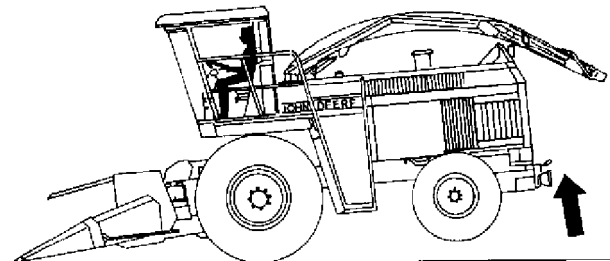

ZX 000 453

-UN-03APR95

ZX000453

ZX.WEIGHT -19-02OCT91



## RADIO AERIAL

If radio aerial is not secured in its transport position before driving on public roads, it may come into contact with low-hanging electrical cables. This would result in the operator suffering a severe electrical shock.

To avoid electrical shock, no portion of the machine should be higher than 4 m (13 ft).

Before transporting machine, bend aerial or remove it.

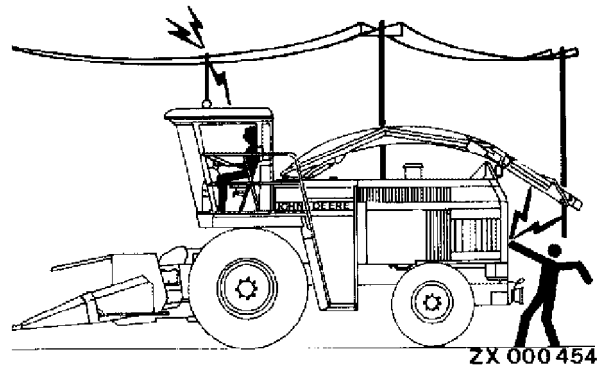

ZX000454 -UN-03APR95

ZX,ANTENNA -19-01JAN93

## PARKING AND LEAVING THE FORAGE HARVESTER

Lower harvesting unit to the ground.

Before leaving the forage harvester, disengage main clutch and shut off engine. Move gear shift lever to neutral, apply parking brake, remove key and lock the operator's cab. Position chock blocks.

*NOTE: Use only chock blocks provided with the machine.*

Never leave forage harvester unattended as long as engine is running.

Never leave the operator's cab when driving.

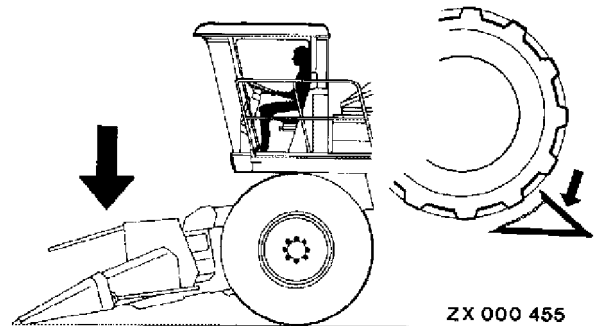

ZX000455 -UN-03APR95

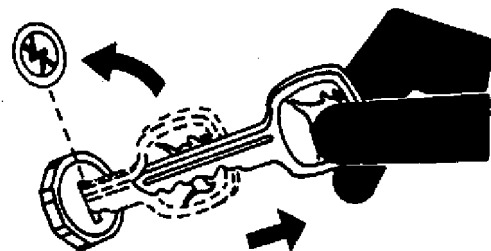

TSS230 -UN-24MAY89

ZX,PARK -19-01OCT91





## WORK IN VENTILATED AREA

Engine exhaust fumes can cause sickness or death. If it is necessary to run an engine in an enclosed area, remove the exhaust fumes from the area with an exhaust pipe extension.

If you do not have an exhaust pipe extension, open the doors and get outside air into the area.

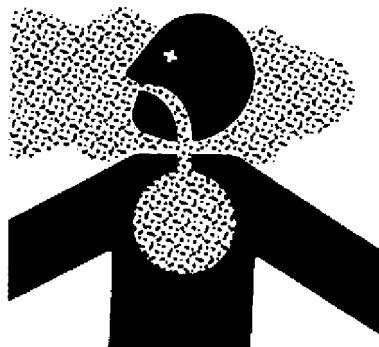

DX,AIR -19-04JUN90

TS220 -UN-23AUG88

## EMERGENCY EXIT

The right-hand cab window may be used as an emergency exit. Disengage the gas-filled spring on the sidewall of the cab and open the window.

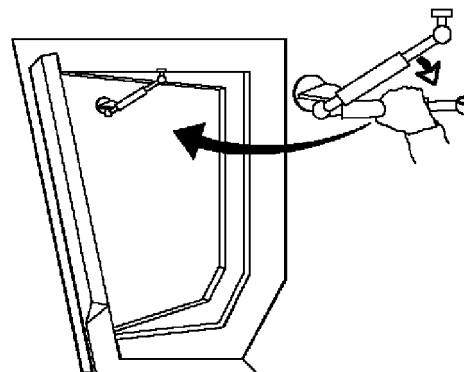

ZX 006004

ZX\_OMSPFH003293-19-01MAY94

ZX006004 -UN-03APR95

## PRACTICE SAFE MAINTENANCE

Understand service procedure before doing work. Keep area clean and dry.

Never lubricate, service, or adjust machine while it is moving. Keep hands, feet, and clothing from power-driven parts. Disengage all power and operate controls to relieve pressure. Lower equipment to the ground. Stop the engine. Remove the key. Allow machine to cool.

Securely support any machine elements that must be raised for service work.

Keep all parts in good condition and properly installed. Fix damage immediately. Replace worn or broken parts. Remove any buildup of grease, oil, or debris.

Disconnect battery ground cable (-) before making adjustments on electrical systems or welding on machine.



DX,SERV -19-03MAR93

TS218 -UN-23AUG88



## SERVICE MACHINES SAFELY

Tie long hair behind your head. Do not wear a necktie, scarf, loose clothing, or necklace when you work near machine tools or moving parts. If these items were to get caught, severe injury could result.

Remove rings and other jewelry to prevent electrical shorts and entanglement in moving parts.

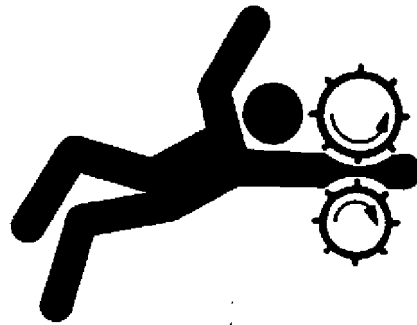

DX.LOOSE -19-04JUN90

TS228  
-UN-23AUG88

## SUPPORT MACHINE PROPERLY

Always lower the attachment or implement to the ground before you work on the machine. If you must work on a lifted machine or attachment, securely support the machine or attachment.

Do not support the machine on cinder blocks, hollow tiles, or props that may crumble under continuous load. Do not work under a machine that is supported solely by a jack. Follow recommended procedures in this manual.

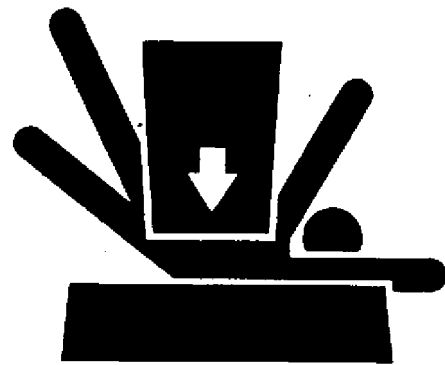

DX.LOWER -19-04JUN90

TS229  
-UN-23AUG88

## RETORQUE WHEEL NUTS

Retorque wheel nuts as specified in Sections "Wheels and Ballast" and "Lubrication, Periodic Services". Failure to do this could result in a wheel falling off during operation, causing the machine to tip over with serious injury to the operator and extensive damage to the machine.

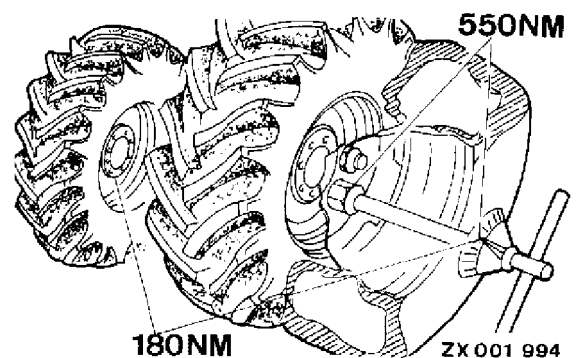

ZX.NUTS -19-11MAY92

ZX001994  
-UN-03APR95



## AVOID HIGH-PRESSURE FLUIDS

Escaping fluid under pressure can penetrate the skin causing serious injury.

Avoid the hazard by relieving pressure before disconnecting hydraulic or other lines. Tighten all connections before applying pressure.

Search for leaks with a piece of cardboard. Protect hands and body from high pressure fluids.

If an accident occurs, see a doctor immediately. Any fluid injected into the skin must be surgically removed within a few hours or gangrene may result. Doctors unfamiliar with this type of injury should reference a knowledgeable medical source. Such information is available from Deere & Company Medical Department in Moline, Illinois, U.S.A.

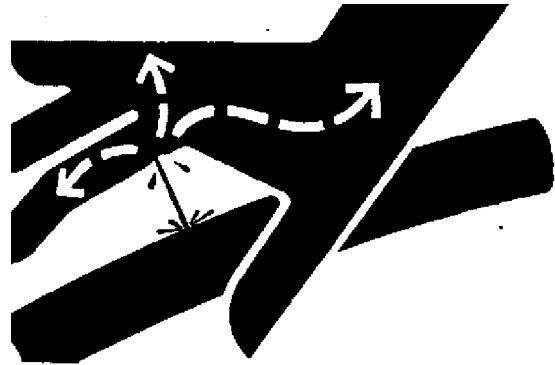

X9811 -UN-23AUG88

DX,FLUID -19-03MAR93

## PREVENT BATTERY EXPLOSIONS

Keep sparks, lighted matches, and open flame away from the top of battery. Battery gas can explode.

Never check battery charge by placing a metal object across the posts. Use a volt-meter or hydrometer.

Do not charge a frozen battery; it may explode. Warm battery to 16°C (60°F).



TS204 -UN-23AUG88

DX,SPARKS -19-03MAR93



## PREVENT ACID BURNS

Sulfuric acid in battery electrolyte is poisonous. It is strong enough to burn skin, eat holes in clothing, and cause blindness if splashed into eyes.

Avoid the hazard by:

1. Filling batteries in a well-ventilated area.
2. Wearing eye protection and rubber gloves.
3. Avoiding breathing fumes when electrolyte is added.
4. Avoiding spilling or dripping electrolyte.
5. Use proper jump start procedure.

If you spill acid on yourself:

1. Flush your skin with water.
2. Apply baking soda or lime to help neutralize the acid.
3. Flush your eyes with water for 15—30 minutes. Get medical attention immediately.

If acid is swallowed:

1. Do not induce vomiting.
2. Drink large amounts of water or milk, but do not exceed 2 L (2 quarts).
3. Get medical attention immediately.

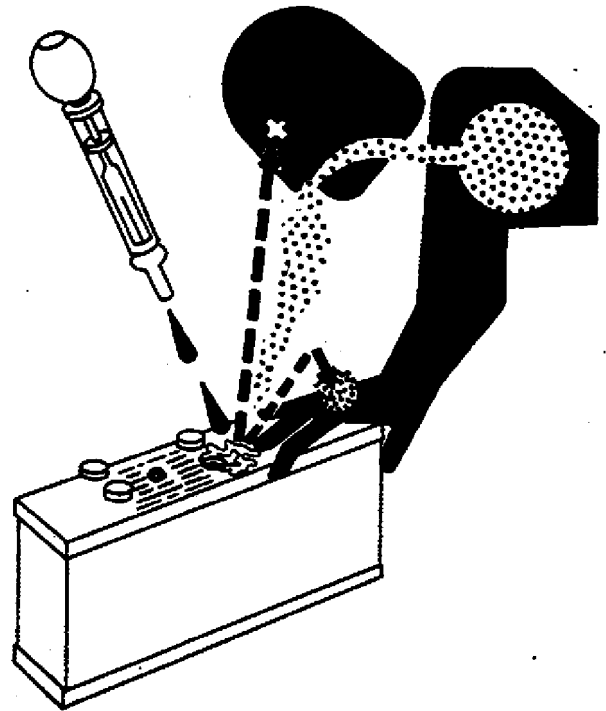

DX\_POISON -19-21APR93

TSS203 -UN-23AUG88



## SERVICE TIRES SAFELY

Explosive separation of a tire and rim parts can cause serious injury or death.

Do not attempt to mount a tire unless you have the proper equipment and experience to perform the job.

Always maintain the correct tire pressure. Do not inflate the tires above the recommended pressure. Never weld or heat a wheel and tire assembly. The heat can cause an increase in air pressure resulting in a tire explosion. Welding can structurally weaken or deform the wheel.

When inflating tires, use a clip-on chuck and extension hose long enough to allow you to stand to one side and NOT in front of or over the tire assembly. Use a safety cage if available.

Check wheels for low pressure, cuts, bubbles, damaged rims or missing lug bolts and nuts.

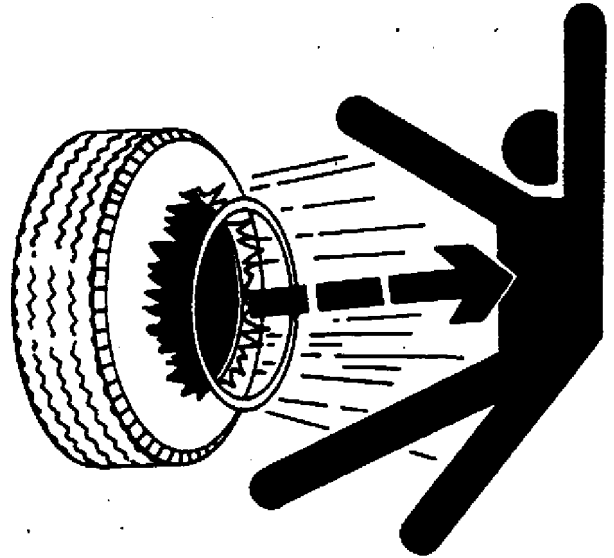

-UN-23AUG88

TS211

DX,RIM -19-24AUG90

## SERVICE COOLING SYSTEM SAFELY

Explosive release of fluids from pressurized cooling system can cause serious burns.

Shut off engine. Only remove filler cap when cool enough to touch with bare hands. Slowly loosen cap to first stop to relieve pressure before removing completely.



-UN-23AUG88

TS281

DX,RCAP -19-04JUN90



## DISPOSE OF WASTE PROPERLY

Improperly disposing of waste can threaten the environment and ecology. Potentially harmful waste used with John Deere equipment include such items as oil, fuel, coolant, brake fluid, filters, and batteries.

Use leakproof containers when draining fluids. Do not use food or beverage containers that may mislead someone into drinking from them.

Do not pour waste onto the ground, down a drain, or into any water source.

Air conditioning refrigerants escaping into the air can damage the Earth's atmosphere. Government regulations may require a certified air conditioning service center to recover and recycle used air conditioning refrigerants.

Inquire on the proper way to recycle or dispose of waste from your local environmental or recycling center, or from your John Deere dealer.

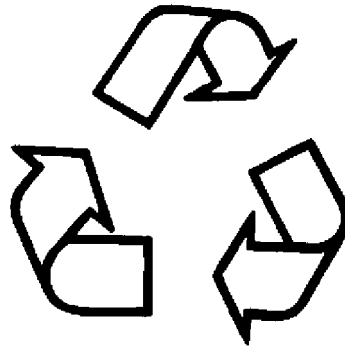

TS1133 -UN-26NOV90

DX,DRAIN -19-03MAR93

# Safety Decals

## PICTORIAL SAFETY SIGNS

At several important places of this machine safety signs are affixed intended to signify potential danger. The hazard is identified by a pictorial in a warning triangle. An adjacent pictorial provides information how to avoid personal injury. These safety signs, their placement on the machine and a brief explanatory text are shown below.



FX,WBZ -19-19NOV91

TS231 -19-07OCT88

## OPERATOR'S MANUAL

This operator's manual contains all important information necessary for safe machine operation. Carefully observe all safety rules to avoid accidents.

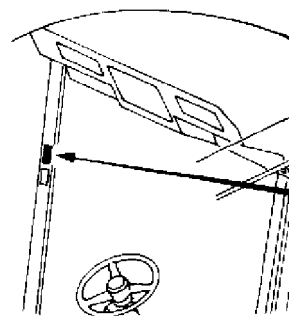

ZX 002470 - 29

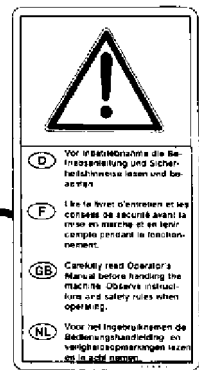

ZX,OM -19-12JUN92

-19-25AUG00  
ZX002470

## REPAIR AND MAINTENANCE

Before carrying out repair and maintenance work, shut off engine and remove key.

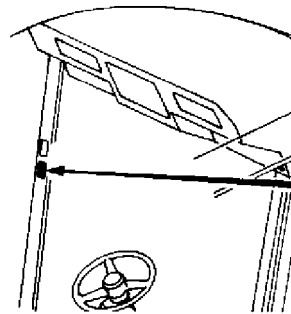

ZX 002471

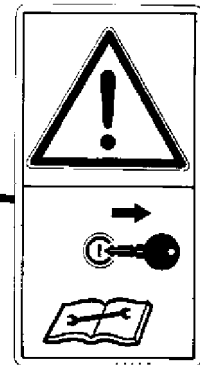

ZX,MAINTENANCE -19-13APR92

-JUN-22MAY95  
ZX002471

## ACCESS LADDER AND PLATFORM

Do not allow riders on access ladder or platform.

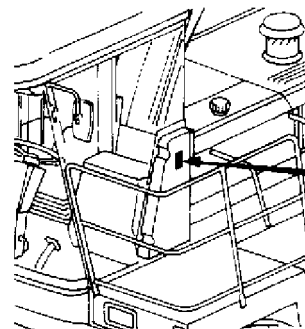

ZX 002472



ZX,RIDER3 -19-04MAY92

-JUN-25AUG00  
ZX002472

**PLATFORM, RIGHT-HAND SIDE**

Do not allow riders on service platform.

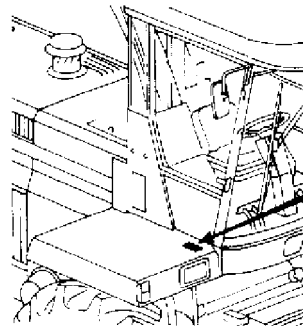

ZX 002473

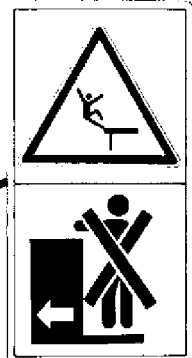

ZX,RIDER4 -19-04MAY92

-UN-25AUG00  
ZX002473

**FEED ROLLS**

Stay clear of rotating feed rolls to avoid personal injury.

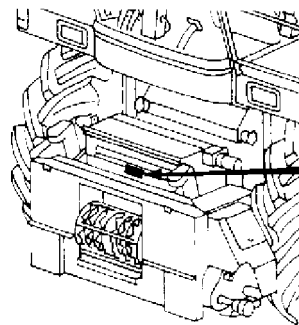

ZX 002474

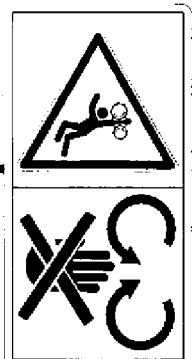

ZX,AUGER -19-04MAY92

-UN-25AUG00  
ZX002474

**CUTTERHEAD ASSEMBLY AND DRIVE**

Do not touch any moving machine parts. Wait until all moving parts have stopped.

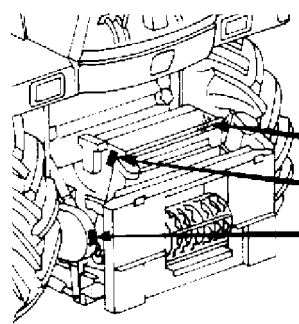

ZX 002475

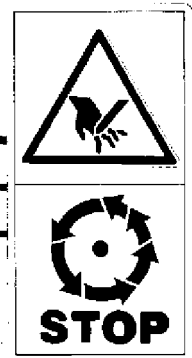

ZX,CUTTER -19-04MAY92

-UN-25AUG00  
ZX002475

**CUTTERHEAD**

Install guard before sharpening knives.

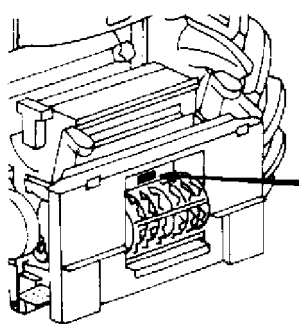

ZX 002476

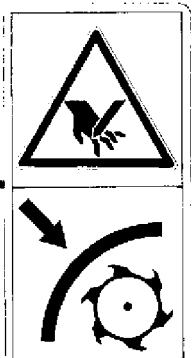

ZX,SHARPENER -19-04MAY92

-UN-25AUG00  
ZX002476



**MAIN DRIVE**

Do not touch any moving machine parts. Wait until all moving parts have stopped.

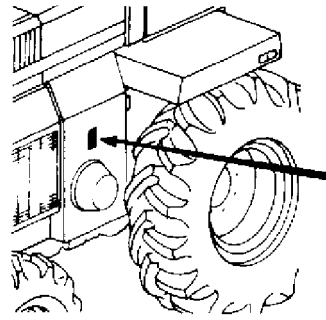

ZX 002477

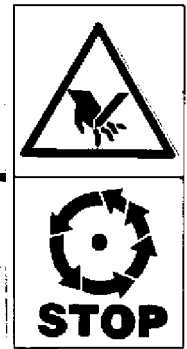

ZX,MAINDRIVE -19-04MAY92

-UN-25AUG00  
ZX002477

**EXHAUST SYSTEM 6610, 6710**

Stay clear of hot surfaces.

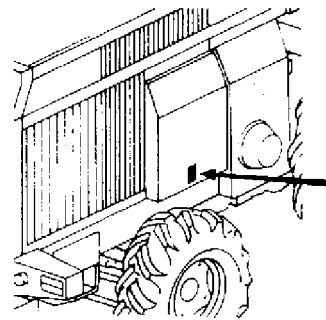

ZX 002478



ZX,EXHAUST1 -19-04MAY92

-UN-25AUG00  
ZX002478

**EXHAUST SYSTEM 6810, 6910**

Stay clear of hot surfaces.

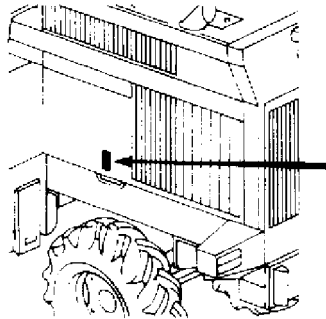

ZX 002479

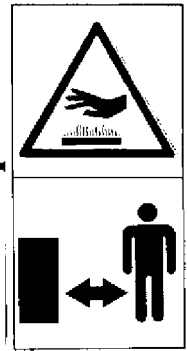

ZX,EXHAUST2 -19-04MAY92

-UN-25AUG00  
ZX002479

**FAN**

Keep away your hands from fan and drive belt when the engine is running.

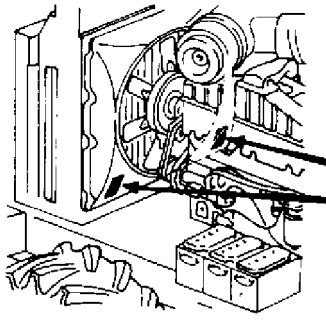

ZX 002480



ZX,FAN -19-04MAY92

-UN-25AUG00  
ZX002480

### FIRE EXTINGUISHER

Do not operate the machine unless a fire extinguisher ready for operation is installed at this location.

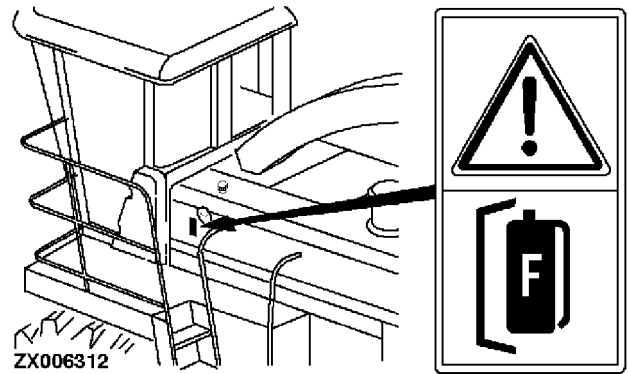

ZX,OMSPFH003394-19-01JUN94

-UN-13FEB96  
ZX006312

### FRONT WHEEL ATTACHING NUTS

Retighten front wheel attaching nuts at specified intervals.

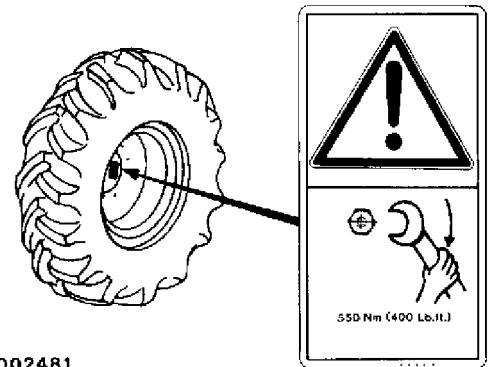

ZX,FRONTWHEEL -19-13APR92

-UN-25AUG00  
ZX002481

### REAR WHEEL ATTACHING BOLTS

Retighten rear wheel attaching bolts at specified intervals.

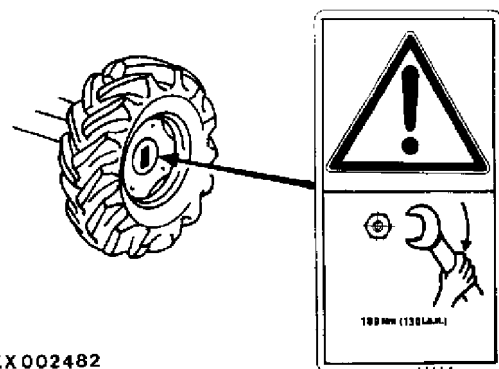

ZX,REARWHEEL -19-13APR92

-UN-22MAY95  
ZX002482

# Controls and Instruments

## GENERAL VIEW OF CONTROLS AND INSTRUMENTS

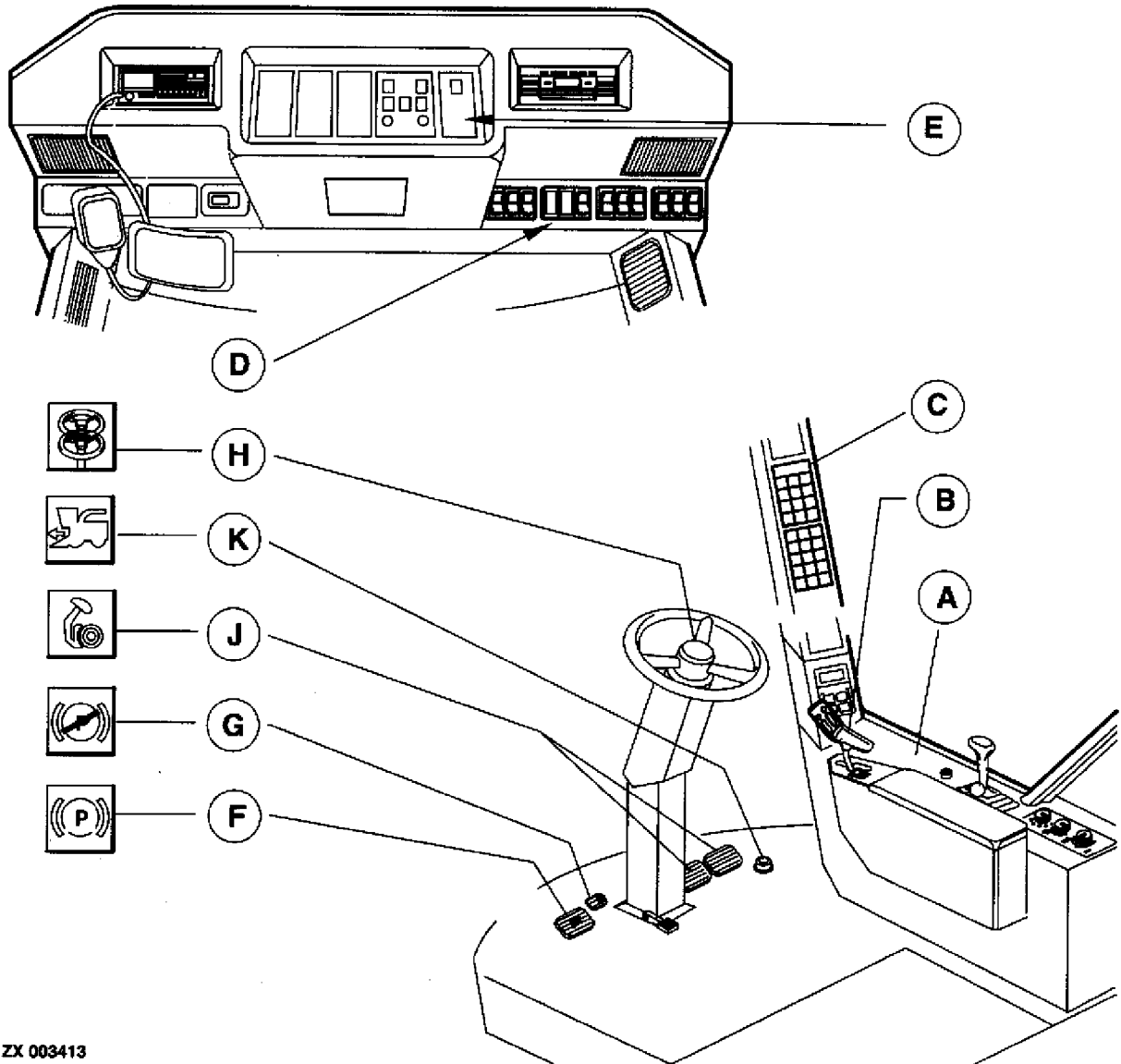

ZX 003413

A—Switch console  
B—Multi-function lever  
C—Corner post instruments

D—Roof switch console  
E—Automatic function control

F—Parking brake  
G—Parking brake release pedal

H—Steering column  
J—Foot brakes  
K—Four-wheel-drive switch

ZX003413 -JUN-25AUG00

ZX,OMSPFH000134-19-11MAY92

Thank you so much for reading.  
Please click the “Buy Now!”  
button below to download the  
complete manual.



After you pay.

You can download the most  
perfect and complete manual in  
the world immediately.

Our support email:

[ebooklibonline@outlook.com](mailto:ebooklibonline@outlook.com)