

664 (From Serial No. 4434)
665R (From Serial No. 1010)
666R (From Serial No. 7288)
Row-Crop Headers



OPERATORS MANUAL

664 (From Serial No. 4434) 665R (From Serial No.
1010) 666R (From Serial No. 7288) Row-Crop
Headers

OMZ92339 Issue G4 Englisch

John Deere Werke Zweibrücken
OMZ92339 Issue G4
North American Edition

LITHO IN U.S.A.
ENGLISCH



Introduction

READ THIS MANUAL carefully to learn how to operate and service your machine correctly. Failure to do so could result in personal injury or equipment damage. This manual and safety signs on your machine may also be available in other languages. (See your John Deere dealer to order.)

THIS MANUAL SHOULD BE CONSIDERED a permanent part of your machine and should remain with the machine when you sell it.

MEASUREMENTS in this manual are given in both metric and customary U.S. unit equivalents. Use only correct replacement parts and fasteners. Metric and inch fasteners may require a specific metric or inch wrench.

RIGHT-HAND AND LEFT-HAND sides are determined by facing in the direction the implement will travel when going forward.

WRITE PRODUCT IDENTIFICATION NUMBERS (P.I.N.) in the Specification section. Accurately record

all the numbers to help in tracing the machine should it be stolen. Your dealer also needs these numbers when you order parts. File the identification numbers in a secure place off the machine.

WARRANTY is provided as part of John Deere's support program for customers who operate and maintain their equipment as described in this manual. The warranty is explained on the warranty certificate which you should have received from your dealer.

This warranty provides you the assurance that John Deere will back its products where defects appear within the warranty period. In some circumstances, John Deere also provides field improvements, often without charge to the customer, even if the product is out of warranty. Should the equipment be abused, or modified to change its performance beyond the original factory specifications, the warranty will become void and field improvements may be denied. Setting fuel delivery above specifications or otherwise overpowering machines will result in such action.

Contents

	Page		Page
Identification Views	00-1	Lubrication and Maintenance	
Safety	05-1	Lubrication intervals	40-1
Safety Decals	10-1	Observe lubrication symbols	40-1
Preparing the Harvester		Grease	40-2
Preparing Series 6000 harvester	15-1	Gear case oil	40-2
Preparing Series 5000 harvester	15-2	Alternative lubricants	40-3
Attaching and Detaching		Draining and refilling gear case	40-4
664, 665R and 666R on Series 6000		Every 10 hours (664 only)	40-5
harvester	20-1	Every 10 hours (664 only)	40-6
664 on Series 5000 harvester	20-2	Every 10 hours (665R, 666R only)	40-7
665R and 666R on Series 5000 harvester ...	20-3	Every 10 hours (665R, 666R only)	40-8
Raise jackstand	20-5	As required	40-9
Detaching the row-crop header	20-5	Every 50 hours	40-10
Transporting		Every 50 hours	40-11
Road regulations	25-1	Every 100 hours (665R, 666R only)	40-12
Installing road protective bar	25-1	Service	
Folding or unfolding (665R, 666R only)	25-1	Torques for hardware	45-1
Unfolding outer units (665R, 666R only)	25-1	Rotating knives	45-2
Folding outer units (665R, 666R only)	25-3	Replacing lower rotating knife	45-2
Operating the Row-Crop Header		Reinstalling lower rotating knife	45-3
Break-in instructions	30-1	Replacing upper rotating knife	45-3
Harvesting preparations	30-2	Gatherer chains	45-4
Pre-operational checks	30-3	Replacing gatherer chain	45-4
Adjusting outer deflectors	30-3	Reinstalling gatherer chain	45-5
Adjusting crop deflectors	30-4	Adjusting pressure at rotating knives	45-8
Adjusting row-crop header float	30-4	Adjusting lateral gatherer chain	45-10
Input and auger drive sprockets	30-5	Adjusting main drive chain (664 only)	45-11
Operating row-crop header	30-6	Adjusting feed auger drive chain (664	
Cleaning and checking after work	30-6	only)	45-11
Changing harvesting unit	30-7	Adjusting drive chains (665R, 666R only) ...	45-12
Storage	30-7	Replacing auger trough wear plate	45-12
Troubleshooting		Storage	
Row-crop header operation	35-1	At end of season	50-1
		Beginning of season	50-1
		Specifications	
		664 row-crop header	55-1
		665R row-crop header	55-2

Continued on next page

All information, illustrations and specifications in this manual are based on the latest information available at the time of publication. The right is reserved to make changes at any time without notice.

GMZ92339 G4-19-28JUN94

COPYRIGHT® 1994
DEERE & COMPANY
European Office Mannheim
All rights reserved
A John Deere ILLUSTRATION™ Manual

Contents

	Page
666R row-crop header	55-3
Serial Number	60-1
Crime Prevention	65-1
Index	

Identification Views

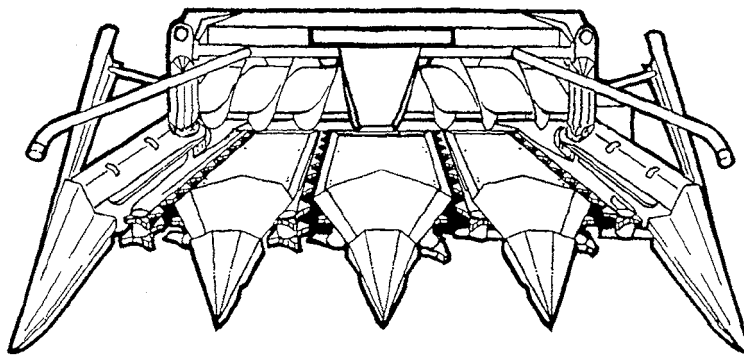

-UN-31MAR95

CC000250

CC000250

664 Row-Crop Header

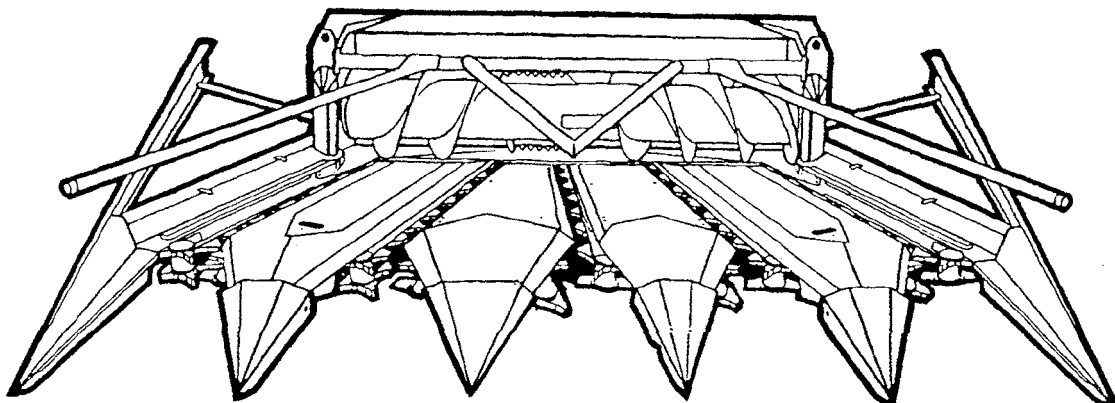

CC 000532

-UN-31MAR95

CC000532

665R Row-Crop Header

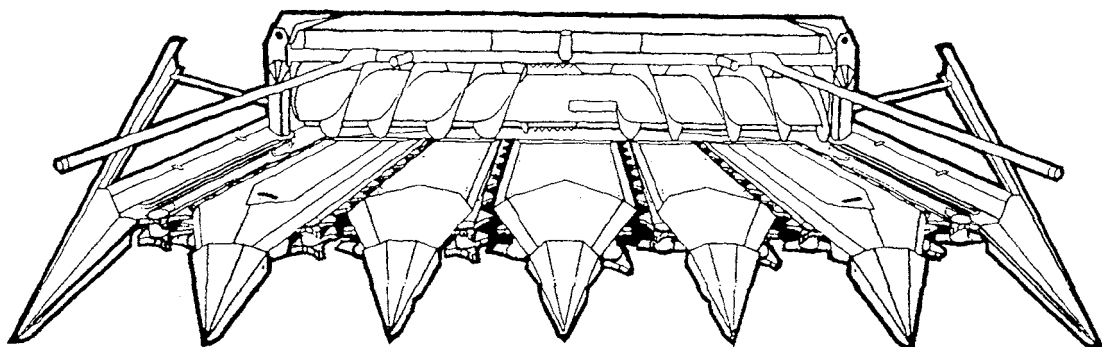

CC 000533

-UN-31MAR95

CC000533

666R Row-Crop Header

CC,665WRC000985-19-26APR93

Safety

RECOGNIZE SAFETY INFORMATION

This is the safety-alert symbol. When you see this symbol on your machine or in this manual, be alert to the potential for personal injury.

Follow recommended precautions and safe operating practices.



DX,ALERT -19-03MAR93

T81589 -UN-07DEC88

FOLLOW SAFETY INSTRUCTIONS

Carefully read all safety messages in this manual and on your machine safety signs. Keep safety signs in good condition. Replace missing or damaged safety signs. Be sure new equipment components and repair parts include the current safety signs. Replacement safety signs are available from your John Deere dealer.

Learn how to operate the machine and how to use controls properly. Do not let anyone operate without instruction.

Keep your machine in proper working condition. Unauthorized modifications to the machine may impair the function and/or safety and affect machine life.

If you do not understand any part of this manual and need assistance, contact your John Deere dealer.

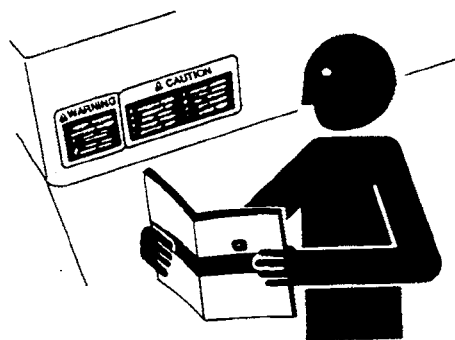

DX,READ -19-03MAR93

TS201 -UN-23AUG88

UNDERSTAND SIGNAL WORDS

A signal word—DANGER, WARNING, or CAUTION—is used with the safety-alert symbol. DANGER identifies the most serious hazards.

DANGER or WARNING safety signs are located near specific hazards. General precautions are listed on CAUTION safety signs. CAUTION also calls attention to safety messages in this manual.



DX,SIGNAL -19-03MAR93

TS187 -19-30SEP88



OBSERVE ROAD TRAFFIC REGULATIONS

Always observe local road traffic regulations when using public roads.

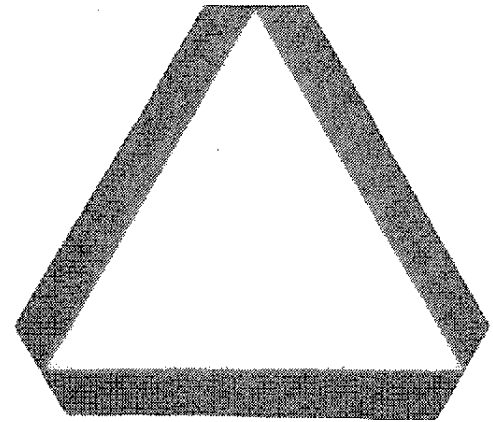

FX,ROAD -19-01MAY91

H28930 -UN-30JUN89

STORE ATTACHMENTS SAFELY

Stored attachments such as dual wheels, cage wheels, and loaders can fall and cause serious injury or death.

Securely store attachments and implements to prevent falling. Keep playing children and bystanders away from storage area.

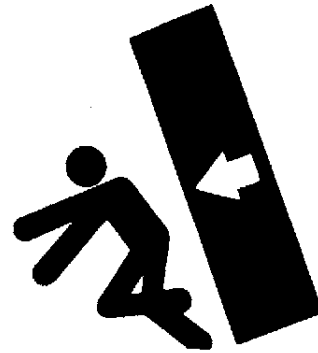

DX,STORE -19-03MAR93

TS219 -UN-23AUG88

PREPARE FOR EMERGENCIES

Be prepared if a fire starts.

Keep a first aid kit and fire extinguisher handy.

Keep emergency numbers for doctors, ambulance service, hospital, and fire department near your telephone.

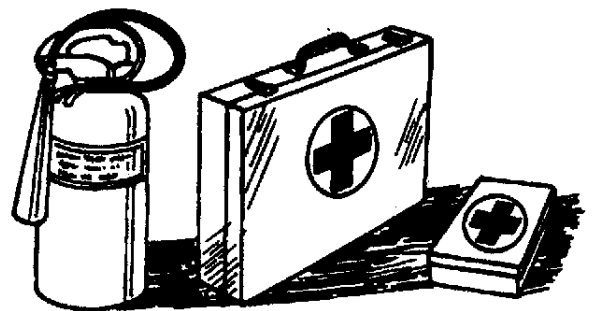

DX,FIRE2 -19-03MAR93

TS291 -UN-23AUG88



WEAR PROTECTIVE CLOTHING

Wear close fitting clothing and safety equipment appropriate to the job.

Prolonged exposure to loud noise can cause impairment or loss of hearing.

Wear a suitable hearing protective device such as earmuffs or earplugs to protect against objectionable or uncomfortable loud noises.

Operating equipment safely requires the full attention of the operator. Do not wear radio or music headphones while operating machine.

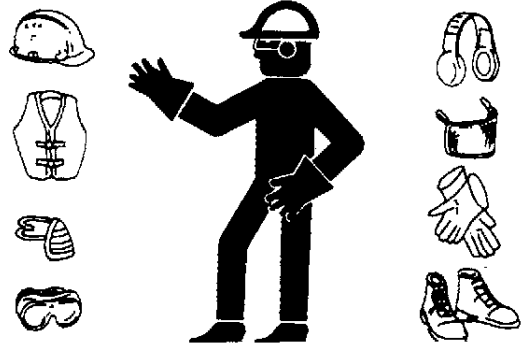

DX,WEAR -19-10SEP90

TS206 -JUN-23AUG88

CHECK MACHINE SAFETY

Always check the road and general operating safety of the machine before using.

FX,READY -19-28FEB91

GUARDS AND SHIELDS

Keep guards and shields in place at all times. Ensure that they are serviceable and installed correctly.

Always disengage main clutch, shut off engine and remove key before removing any guards or shields.

Keep hands, feet and clothing away from moving parts.

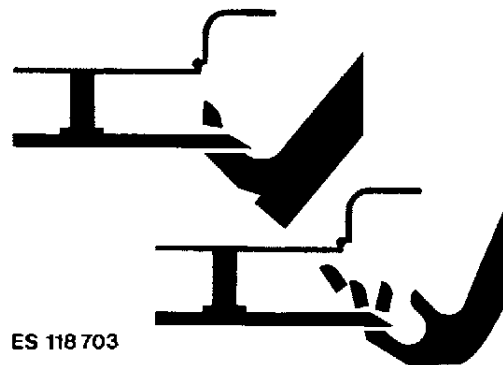

ES 118 703

FX,DEVICE -19-04DEC80

ES118703 -JUN-21/MAR96



USE SAFETY LIGHTS AND DEVICES

Slow moving tractors, self-propelled equipment and towed implements or attachments can create a hazard when driven on public roads. They are difficult to see, especially at night. Avoid personal injury or death resulting from collision with a vehicle.

Whenever driving on public roads, use flashing warning lights and turn signal according to local regulation. To increase visibility, use the lights and devices provided with your machine. For some equipment, install extra flashing warning lights.

Keep safety items in good condition. Replace missing or damaged items. An implement safety lighting kit is available from your John Deere dealer.

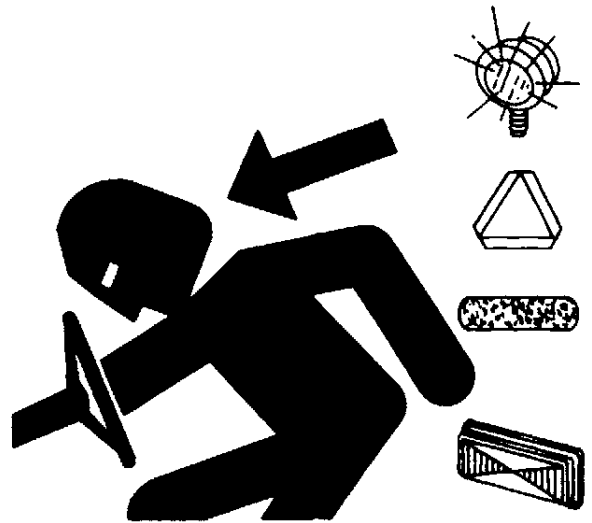

DX,FLASH -19-15MAR93

TS951
-JUN-12APR90

KEEP HANDS AWAY FROM KNIVES

Never attempt to clear obstructions in front of or on harvesting unit unless main clutch is disengaged, engine shut off and key removed.

Everyone must be clear of the forage harvester before starting the engine.



FX,KNIFE -19-21DEC90

TS254
-JUN-22AUG88



PRACTICE SAFE MAINTENANCE

Understand service procedure before doing work. Keep area clean and dry.

Never lubricate, service, or adjust machine while it is moving. Keep hands, feet, and clothing from power-driven parts. Disengage all power and operate controls to relieve pressure. Lower equipment to the ground. Stop the engine. Remove the key. Allow machine to cool.

Securely support any machine elements that must be raised for service work.

Keep all parts in good condition and properly installed. Fix damage immediately. Replace worn or broken parts. Remove any buildup of grease, oil, or debris.

Disconnect battery ground cable (-) before making adjustments on electrical systems or welding on machine.



TS216
-UN-23AUG88

DX,SERV -19-03MAR93

SERVICE MACHINES SAFELY

Tie long hair behind your head. Do not wear a necktie, scarf, loose clothing, or necklace when you work near machine tools or moving parts. If these items were to get caught, severe injury could result.

Remove rings and other jewelry to prevent electrical shorts and entanglement in moving parts.

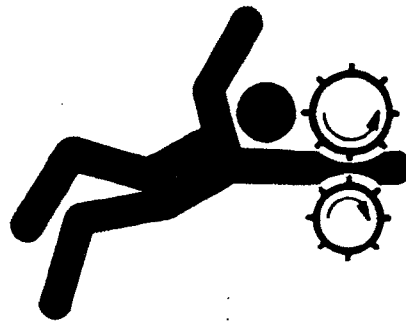

TS228
-UN-23AUG88

DX,LOOSE -19-04JUN90



SUPPORT MACHINE PROPERLY

Always lower the attachment or implement to the ground before you work on the machine. If you must work on a lifted machine or attachment, securely support the machine or attachment.

Do not support the machine on cinder blocks, hollow tiles, or props that may crumble under continuous load. Do not work under a machine that is supported solely by a jack. Follow recommended procedures in this manual.

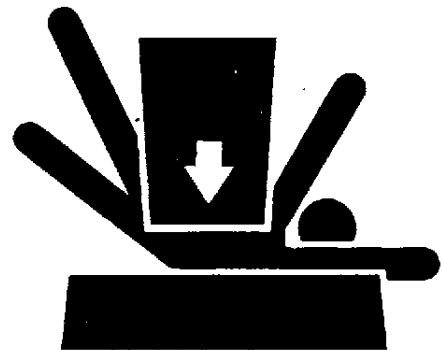

ZX,LOWER -19-04JUN90

TSP29 -UN-23AUG88

TRANSPORT WITH HARVESTING UNIT INSTALLED

Before driving forage harvester on public roads, harvesting unit must be raised and secured in this position. It must not, however, obstruct operator's view of the road. Remove crop dividers (if equipped) and install protective cover.

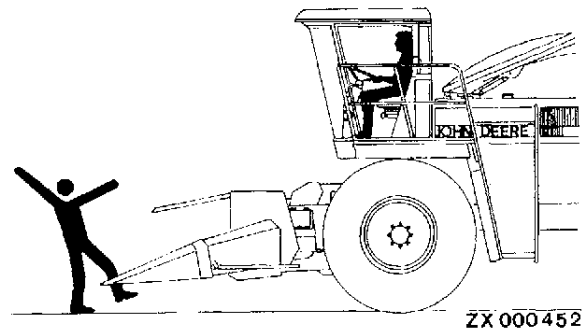

ZX,HEADER -19-04DEC90

ZX000452 -UN-03APR95

BALLASTING FOR SAFE GROUND CONTACT

Operating, steering and braking performance of forage harvester can be considerably affected by attachments which alter the center of gravity of the machine. To maintain safe ground contact, ballast the harvester at the rear end as necessary. Observe the maximum permissible axle loads and total weights.

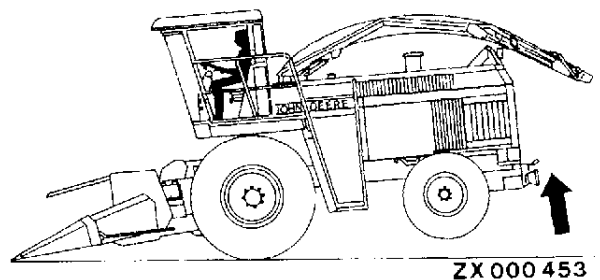

ZX,WEIGHT -19-02OCT91

ZX000453 -UN-03APR95

Thank you so much for reading.
Please click the “Buy Now!”
button below to download the
complete manual.



After you pay.

You can download the most
perfect and complete manual in
the world immediately.

Our support email:

ebooklibonline@outlook.com