

**680, 690, 680 MultiCut  
and 690 MultiCut  
Large Square Balers**  
(From Serial No. 423887)

**John Deere Werke Zweibrücken  
OMZ92761 Issue C9**

European Version  
Printed in Germany  
**ENGLISCH**

# Contents

	Page		Page
<b>Identification View</b> . . . . .	00-1	<b>Transporting</b>	
<b>Safety</b> . . . . .	05-1	Observe road transport regulations . . . . .	25-1
<b>Safety Decals</b>		Raising pick-up . . . . .	25-1
<b>Preparing the Baler</b>		Folding in bale discharge chute (mechanical) . . . . .	25-2
Tire inflation . . . . .	15-1	Securing bale discharge chute (mechanical) . . . . .	25-2
Loading twine boxes . . . . .	15-1	Folding in bale discharge chute (hydraulic) . . . . .	25-2
Twine knot . . . . .	15-2	Lighting system . . . . .	25-3
Inserting the twine . . . . .	15-2	Shunting without air brake connected . . . . .	25-3
Feeding twine into twine brake . . . . .	15-3	<b>Electronic Controls</b>	
Twine path (680 baler) . . . . .	15-4	On-board computer . . . . .	30-1
Twine path (690 baler) . . . . .	15-5	Control and indicator box . . . . .	30-2
<b>Attaching and Detaching</b>		Control functions . . . . .	30-3
Preparation . . . . .	20-1	Adjusting bale density . . . . .	30-4
Adjusting tongue height . . . . .	20-1	Bale density correction . . . . .	30-5
Jointed shaft . . . . .	20-2	Releasing the bale channel . . . . .	30-7
Adapting the jointed shaft . . . . .	20-3	Bale counter . . . . .	30-8
Attaching baler to tractor . . . . .	20-3	Information display . . . . .	30-8
Tongue spacer bushing . . . . .	20-4	Alarm messages . . . . .	30-9
Securing jackstand . . . . .	20-4	Blade check at cutting mechanism . . . . .	30-11
Using jackstand crank . . . . .	20-4	Checking sensors and valves . . . . .	30-11
Hydraulic connections . . . . .	20-5	Rake sensor test . . . . .	30-12
Compressed air connections . . . . .	20-5	Knottter sensor test . . . . .	30-12
Hydraulic brake . . . . .	20-6	Blade sensor test . . . . .	30-12
Securing jointed shaft . . . . .	20-6	Twine sensor test . . . . .	30-13
Attaching jointed shaft . . . . .	20-7	Calibration sensor test . . . . .	30-13
Electrical connection . . . . .	20-8	Measurement sensor test . . . . .	30-13
Disengaging parking brake . . . . .	20-8	General sensor test . . . . .	30-13
Checking hydraulic system oil level . . . . .	20-9	Language entry . . . . .	30-14
Detaching the baler . . . . .	20-9	Checking the valves . . . . .	30-14
Chock blocks and parking brake . . . . .	20-10	Knottter cleaning valve test . . . . .	30-14
Jackstand and jointed shaft (top attachment) . . . . .	20-10	Baling pressure control valves . . . . .	30-15
Compressed air and hydraulic hoses (top attachment) . . . . .	20-11	Bale chamber opening valve . . . . .	30-15
Hydraulic hoses and jointed shaft (bottom attachment) . . . . .	20-11	Bale chamber closing valve test . . . . .	30-15
		Bale chamber pressure regulating valve . . . . .	30-15
		<b>Operating the Baler</b>	
		Right-hand side view . . . . .	35-1

Continued on next page

*All information, illustrations and specifications in this manual are based on the latest information available at the time of publication. The right is reserved to make changes at any time without notice.*

OMZ92761 C9-19-01MAR99

COPYRIGHT© 1999  
DEERE & COMPANY  
European Office Mannheim  
All rights reserved  
A John Deere ILLUSTRATION® Manual

## Contents

	<b>Page</b>		<b>Page</b>
Left-hand side view . . . . .	35-3	Compressed air tanks-Weekly . . . . .	45-8
How the large square baler works . . . . .	35-5	Brake cylinders-Weekly . . . . .	45-9
Maintenance platform . . . . .	35-7	Hydraulic system-Annually . . . . .	45-9
Fire extinguisher . . . . .	35-7	Changing and checking the oil in the gearboxes . . . . .	45-10
Main drive . . . . .	35-7	Main gearbox-Annually . . . . .	45-10
Feed rake drum drive . . . . .	35-8	Feed rake gearbox-Annually . . . . .	45-11
Knotter shaft drive . . . . .	35-8	Double angular gearbox-Annually . . . . .	45-11
Pick-up drive . . . . .	35-8	Pickup gearboxes-Annually . . . . .	45-12
Pickup general information . . . . .	35-8	MultiCut angel drive gear-Annually . . . . .	45-13
Adjusting pick-up working height . . . . .	35-9	MultiCut distributor drive gear-Annually . . . . .	45-14
Adjusting depth stop . . . . .	35-9		
Adjusting baffle plate height . . . . .	35-10	<b>Troubleshooting</b>	
Adjusting bale discharge chute . . . . .	35-11	Warning and indicator lamp . . . . .	50-1
Baling pressure . . . . .	35-11	Needle yoke . . . . .	50-1
Adjusting bale length . . . . .	35-12	Knotter mechanism . . . . .	50-1
Checking knotting . . . . .	35-12	Rake drum . . . . .	50-2
Electric twine fault display . . . . .	35-12	Electronic controls . . . . .	50-3
Tripping the twine tying cycle by hand . . . . .	35-13	Other malfunctions . . . . .	50-4
Emptying the bale channel . . . . .	35-14		
Cutting mechanism (680 and 690 only) . . . . .	35-15	<b>Service</b>	
Removing and installing blades . . . . .	35-15	General information . . . . .	55-2
MultiCut cutting platform . . . . .	35-16	Tires . . . . .	55-3
Adjusting length of cut (MultiCut) . . . . .	35-16	Opening the front guard . . . . .	55-4
Changing the blades (Multicut) . . . . .	35-18	Installing new shear bolt . . . . .	55-4
Blade adjusting shaft lock-out . . . . .	35-20	Adjusting needle position . . . . .	55-5
Locking out free-wheel . . . . .	35-22	Checking needle relative to plunger setting . . . . .	55-7
Compressor . . . . .	35-23	Twine bar . . . . .	55-8
Swath distributor . . . . .	35-24	Adjusting twine bar . . . . .	55-8
		Adjusting plunger . . . . .	55-9
<b>Lubricants and Capacities</b>		Cleaning plunger guide rail . . . . .	55-10
Gear oil . . . . .	40-1	Replacing rake guide rollers . . . . .	55-10
Use of gear oil . . . . .	40-2	Setting the rake relative to the plunger . . . . .	55-10
Hydraulic oil . . . . .	40-3	Adjusting rake drum sensor . . . . .	55-11
Use of hydraulic oil . . . . .	40-3	Adjusting piston rod sensors . . . . .	55-12
Grease . . . . .	40-4	Adjusting cutting mechanism sensor (680 and 690) . . . . .	55-12
Alternative and synthetic lubricants . . . . .	40-5	Adjusting blade adjusting shaft sensor . . . . .	55-13
Mixing of lubricants . . . . .	40-5	Adjusting knotter sensor . . . . .	55-13
Lubricant storage . . . . .	40-5	Adjusting the blade safety mechanism . . . . .	55-14
Use genuine John Deere parts . . . . .	40-6	Adjusting flywheel cleaning device . . . . .	55-15
		Adjusting twine brake . . . . .	55-15
<b>Lubrication, Periodic Service</b>		Checking twine tension . . . . .	55-16
General information . . . . .	45-1	Knotter safety rules . . . . .	55-16
Service intervals . . . . .	45-1	Adjusting knotter hook . . . . .	55-17
Important lubricating points . . . . .	45-2	Adjusting knotter twine mount . . . . .	55-18
Main jointed shaft-As indicated . . . . .	45-2	Adjusting knotter blade lever . . . . .	55-19
L.H lubricating points-As indicated . . . . .	45-3	Straightening knotter blade lever . . . . .	55-20
R.H lubricating points-As indicated . . . . .	45-5	Checking knotter blade lever wear . . . . .	55-20
Cleaning baler-Daily . . . . .	45-7		
Cleaning compressor filter-Daily . . . . .	45-7		
Air brakes-Weekly . . . . .	45-8		

Continued on next page

Contents

Page

**Storage**

After the season . . . . . 60-1  
Removing baler from storage . . . . . 60-3  
Freeing main jointed shaft slip clutch . . . . . 60-4

**Specifications** . . . . . 65-1

**Serial Number**

Serial number plate . . . . . 70-1  
Product identification . . . . . 70-1

**Index**

*Contents*

# Identification View

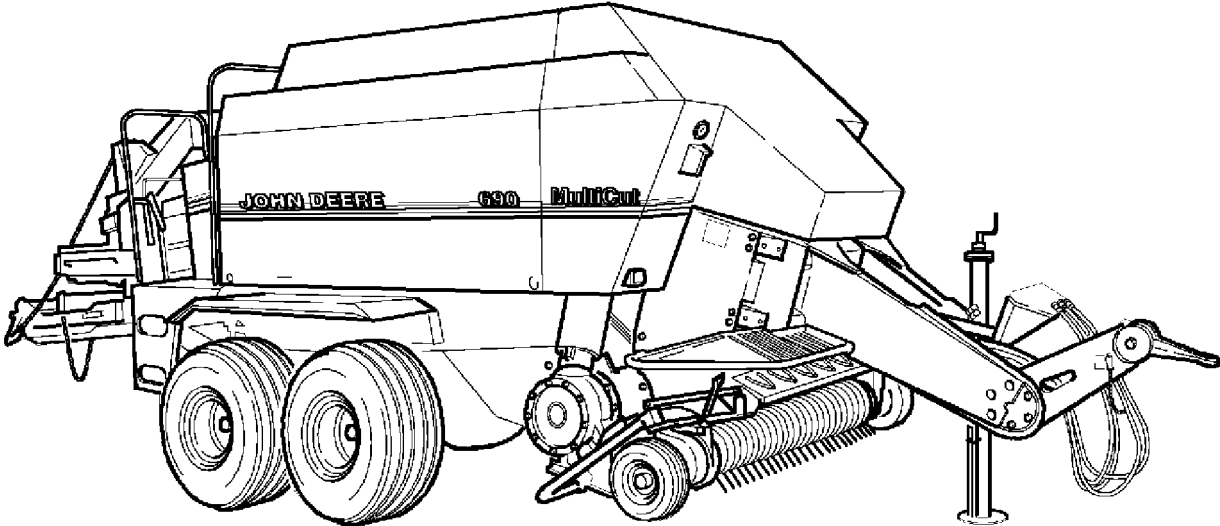

ZX015865

690 Large Square Baler

ZX,OMGPP1004413-19-01NOV98

ZX015865 -JUN-28NOV98

# Safety

## RECOGNIZE SAFETY INFORMATION

This is the safety-alert symbol. When you see this symbol on your machine or in this manual, be alert to the potential for personal injury.

Follow recommended precautions and safe operating practices.

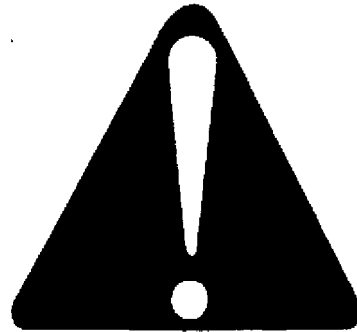

DX,ALERT -19-29SEP98

T81389 -UN-07DEC68

## FOLLOW SAFETY INSTRUCTIONS

Carefully read all safety messages in this manual and on your machine safety signs. Keep safety signs in good condition. Replace missing or damaged safety signs. Be sure new equipment components and repair parts include the current safety signs. Replacement safety signs are available from your John Deere dealer.

Learn how to operate the machine and how to use controls properly. Do not let anyone operate without instruction.

Keep your machine in proper working condition. Unauthorized modifications to the machine may impair the function and/or safety and affect machine life.

If you do not understand any part of this manual and need assistance, contact your John Deere dealer.

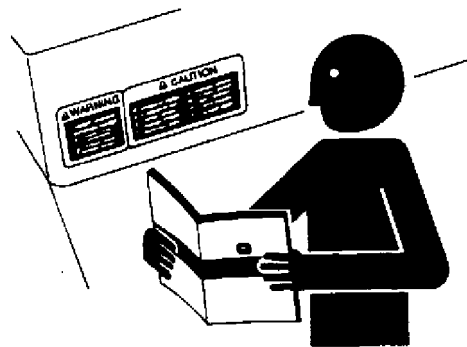

DX,READ -19-03MAR93

T5201 -UN-23AUG88

## UNDERSTAND SIGNAL WORDS

A signal word—DANGER, WARNING, or CAUTION—is used with the safety-alert symbol. DANGER identifies the most serious hazards.

DANGER or WARNING safety signs are located near specific hazards. General precautions are listed on CAUTION safety signs. CAUTION also calls attention to safety messages in this manual.



DX,SIGNAL -19-03MAR93

TS187 -19-30SEP88



## OBSERVE ROAD TRAFFIC REGULATIONS

Always observe local road traffic regulations when using public roads.



FX,ROAD -19-01MAY91

H28930 -UN-30JUN89

## PREPARE FOR EMERGENCIES

Be prepared if a fire starts.

Keep a first aid kit and fire extinguisher handy.

Keep emergency numbers for doctors, ambulance service, hospital, and fire department near your telephone.

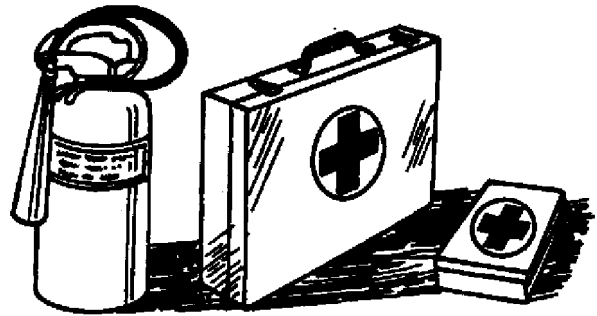

DX,FIRE2 -19-03MAR93

TS291 -UN-23AUG88

## WEAR PROTECTIVE CLOTHING

Wear close fitting clothing and safety equipment appropriate to the job.

Prolonged exposure to loud noise can cause impairment or loss of hearing.

Wear a suitable hearing protective device such as earmuffs or earplugs to protect against objectionable or uncomfortable loud noises.

Operating equipment safely requires the full attention of the operator. Do not wear radio or music headphones while operating machine.

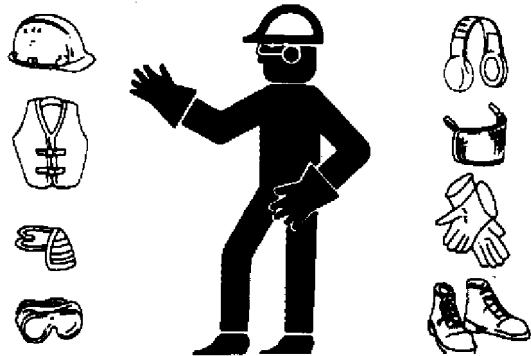

DX,WEAR -19-10SEP90

TS206 -UN-23AUG88





## CHECK MACHINE SAFETY

Always check the road and general operating safety of the machine before using.

FX,READY -19-28FEB91

## STAY CLEAR OF ROTATING DRIVELINES

Entanglement in rotating driveline can cause serious injury or death.

Keep tractor master shield and driveline shields in place at all times. Make sure rotating shields turn freely.

Wear close fitting clothing. Stop the engine and be sure PTO driveline is stopped before making adjustments, connections, or cleaning out PTO driven equipment.



TS1644 -UN-22AUG95

DX,PTO -19-12SEP95

## USE SAFETY LIGHTS AND DEVICES

Prevent collisions between other road users, slow moving tractors with attachments or towed equipment, and self-propelled machines on public roads. Frequently check for traffic from the rear, especially in turns, and use hand signals or turn signal lights.

Use headlights, flashing warning lights, and turn signals day and night. Follow local regulations for equipment lighting and marking. Keep lighting and marking visible and in good working order. Replace or repair lighting and marking that has been damaged or lost.

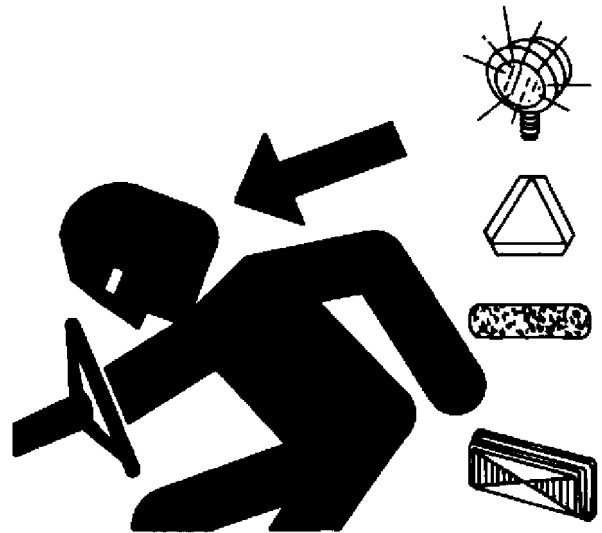

TS951 -UN-12APR90

DX,FLASH -19-04FEB99



## USE A SAFETY CHAIN

A safety chain will help control drawn equipment should it accidentally separate from the drawbar.

Using the appropriate adapter parts, attach the chain to the tractor drawbar support or other specified anchor location. Provide only enough slack in the chain to permit turning.

See your John Deere dealer for a chain with a strength rating equal to or greater than the gross weight of the towed machine. Do not use safety chain for towing.

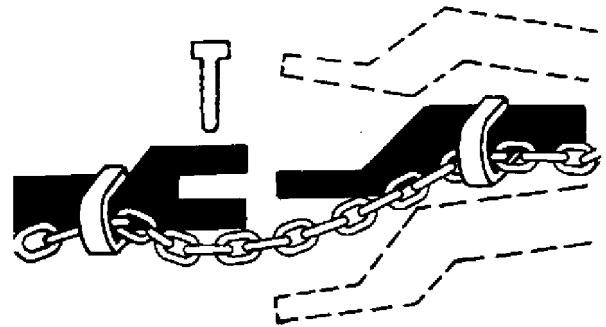

-UN-23AUG68  
TS217

DX,CHAIN -19-03MAR93

## OPERATE BALER SAFELY

To avoid injury or death by being pulled into the machine:

- DO NOT attempt to feed crop or twine into baler or unplug feed area WHILE BALER IS RUNNING. The baler feeds material faster than you can release it.
- Disengage PTO, shut off engine and apply flywheel brake.
- Stand clear of baler at all times when machine is operating.

ZX,OMGPP1004541-19-23SEP95

## EXTINGUISHING A FIRE

1. Eject bale immediately.
2. Move tractor and baler upwind as far as possible from flammable material.
3. Fold in bale chute.
4. Use pressurized water fire extinguisher or other water supply to put out fire.

ZX,OMGPP1004665-19-23SEP95



## PRACTICE SAFE MAINTENANCE

Understand service procedure before doing work. Keep area clean and dry.

Never lubricate, service, or adjust machine while it is moving. Keep hands, feet, and clothing from power-driven parts. Disengage all power and operate controls to relieve pressure. Lower equipment to the ground. Stop the engine. Remove the key. Allow machine to cool.

Securely support any machine elements that must be raised for service work.

Keep all parts in good condition and properly installed. Fix damage immediately. Replace worn or broken parts. Remove any buildup of grease, oil, or debris.

On self-propelled equipment, disconnect battery ground cable (-) before making adjustments on electrical systems or welding on machine.

On towed implements, disconnect wiring harnesses from tractor before servicing electrical system components or welding on machine.



DX,SERV -19-04FEB99

-UN-23AUG88

TSS218

Thank you so much for reading.  
Please click the “Buy Now!”  
button below to download the  
complete manual.



After you pay.

You can download the most  
perfect and complete manual in  
the world immediately.

Our support email:

[ebooklibonline@outlook.com](mailto:ebooklibonline@outlook.com)